



**MISSOURI DEPARTMENT OF TRANSPORTATION  
ST. LOUIS DISTRICT  
SOLICITATION GUIDELINES AND DOCUMENTATION**

**REQUEST FOR BID SL14-040-RW**

It is the vendor's responsibility to read and comply with all conditions, specifications, and instructions outlined in this document. This document and any subsequent attachments shall supersede all confirmation forms, receipts, or any other paperwork needed to secure materials, equipment, or services

<p align="center"><b>REQUEST # SL14-040-RW</b></p> <p align="center">REFERENCE THIS NUMBER ON YOUR RFB RESPONSE &amp; ANY CORRESPONDENCE ABOUT THIS SOLICITATION.</p>	<p align="center"><b>RESPONSES DUE NO LATER THAN:</b></p> <p align="center">NOVEMBER 7, 2013 10:00 A.M. CST</p>
<p>Mailing Address: Procurement Office SL District 2309 Barrett Station Rd Ballwin, MO. 63021</p>	<p>BUYER NAME: TERESA ( TERRI) MOUNT, SR. PROCUREMENT AGENT 314-301-1431, TERESA.MOUNT@MODOT.MO.GOV <b>RFB RESPONSES ARE NOT ACCEPTED BY FAX</b></p>

MoDOT may require **CONTRACT SNOW REMOVAL ASSISTANCE** during the 2013-2014 winter season. This RFB will establish a price agreement for the services of vendors with **EQUIPMENT AND OPERATORS** that may be able to assist with on-call, as-needed, if-needed snow removal operations.

After the response deadline, MoDOT will tabulate all information provided to establish a price agreement list and will contact vendors when and if services are needed during the 2013-2014 winter season.

MoDOT's St. Louis District is soliciting bid pricing for the following types of equipment with operators:

- Item #1 (pricing page 3): Motorgraders
- Item #2 (pricing page 4): Loaders
- Item #3 (pricing page 5): Dump Trucks
- Item #4 (pricing page 6): Tractor-Trailer Units (Low Boy Trailers)
- Item #5 (pricing page 7): Escort Vehicles

Tire chains (contractor provided) and/or 4-wheel drive may be required for mobility so equipment will be effective when maneuvering or when pushing snow.

**SPECIAL TERMS AND CONDITIONS**

**FUEL:** Fuel may be furnished by MoDOT for equipment engaged in snow removal operations. Equipment shall arrive at each assignment fully fueled, and MoDOT will provide fuel as required for operations, such that each piece of equipment leaves their assignment fully fueled. As external parties do not have a fuel card that will be recognized by MoDOT's automated fuel system, in order for these agencies to obtain fuel at a MoDOT facility, a MoDOT staff member must be present during fueling to use their PIN# to authorize the transaction.

**BLADES:** Carbide steel cutting edges for snow removal operations may be supplied by MoDOT for motorgraders. If provided, these will be contractor installed at no additional cost. Any blades supplied by MoDOT must be contractor un-installed and returned to MoDOT at no additional cost when work is completed. Refer to Attachment One (page 9) for details on the carbide blades which may be provided.

**LIGHTING:** At MoDOT's discretion, an escort vehicle may be required to accompany slow moving equipment units (motorgraders, etc.) while performing snow removal operations on an active highway. Escort vehicles shall be equipped with protective lighting equal to "Level 4" MoDOT Fleet Lighting requirements: 1 amber or amber/white flasher LED mini lightbar (24" maximum) or 2 amber flashers with 360 degree visibility. All lighting should meet SAEJ595 or SAE J845 Class 1 standard, verified by an AMECA (Automotive Manufacturers Equipment Compliance Agency) certified lab.

**INSURANCE:** The Contractor shall maintain or cause to be maintained at Contractor's own expense commercial general liability, automobile liability, worker's compensation insurance against negligent acts, errors or omissions of the Contractor, or its subcontractors and anyone directly or indirectly employed by any of them. Any insurance policy required as specified in this Section shall be written by a company that is licensed and authorized to issue such insurance in the state of Missouri and shall provide insurance coverage for not less than the following limits of liability:

- 1) General Liability: Not less than **\$500,000** for any one person in a single accident or occurrence, and not less than **\$3,000,000** for all claims arising out of a single occurrence;
- 2) Automobile Liability: Not less than \$500,000 for any one person in a single accident or occurrence, and not less than \$3,000,000 for all claims arising out of a single occurrence;
- 3) Missouri State Workmen's Compensation policy or equivalent in accordance with state law.

**After award, the Contractor must provide a copy of his/her Certificate of Insurance showing coverage, in the amounts required above.** MoDOT reserves the right, at its sole discretion, to determine the date by which this documentation must be provided. The Contractor's inability to provide this documentation may result in his/her bid being rejected.

MoDOT shall be listed as a "Certificate Holder" on the Certificate of Insurance with the following address:

Missouri Department of Transportation  
St. Louis District  
1590 WoodLake Dr.  
Chesterfield, MO. 63017-5712

**AWARD & PAYMENT:** MoDOT reserves the right to a multiple contract award based upon contractor location, equipment availability and contract costs. Contractor selection at the time of an event shall be made on a "Case By Case/Item By Item/County By County" basis using the "lowest and best" principle of award based on MoDOT needs, equipment availability, and the situation at the time services may be required. There is no guarantee any work will be awarded under this RFB. **Since mobilizations costs are to be included in the hourly rates bid, payment for services will be computed based upon the time of arrival at the designated work location and upon the time of departure from the site at the completion of all requested work.**

**E-VERIFY:** Due to the possibility cost of services will exceed \$5,000, vendors will must comply with the requirements of, complete the forms for, and provide related to, the federal E-Verify program.

#### VENDOR NOTES

VENDORS MAY ATTACH OTHER PERTINENT/SUPPORTING DATA WITH THEIR RESPONSE TO THIS SOLICITATION.

**All responses to this solicitation should be submitted on this form and returned to the buyer listed above at the district address shown. Responses must be mailed, or hand-delivered. Sealed bid responses may NOT be faxed or emailed.**

# PRICING PAGE

## ITEM #1: Motorgraders

Provide the requested information for each piece of equipment you could have available when called upon, for each maintenance area you could provide service in, (you do not need to bid all areas).

Copy this page and submit separate responses if you have multiple pieces of equipment available.

**The hourly rates bid are to include mobilization costs (the cost of getting to and from the work area).**

**VENDOR NAME:**

(Please enter your company name in this block)

**TYPE OF EQUIPMENT:**

(Make, Model, Size of Motorgrader)

Please indicate if the motorgrader could have a wing plow available, and if that could be a right wing or left wing.

County	Maintenance Work Area	Zip Code	HOURLY RATE (with operator)	RESPONSE TIME (How long would it take you to get to the maintenance area after being called?)
St. Louis City			\$	
St. Louis County			\$	
St. Charles			\$	
Jefferson			\$	
Franklin			\$	
			\$	
			\$	
			\$	
			\$	
			\$	
			\$	
			\$	
			\$	
			\$	
			\$	

Provide an hourly rate for Standby Time, payable after call-out, if and when staging of equipment in anticipation of upcoming winter weather is required.

\$

Provide an hourly rate for Operator Training.

\$

# PRICING PAGE

## ITEM #2: Loaders

Provide the requested information for each piece of equipment you could have available when called upon, for each maintenance area you could provide service in, (you do not need to bid all areas).

Copy this page and submit separate responses if you have multiple pieces of equipment available.

**The hourly rates bid are to include mobilization costs (the cost of getting to and from the work area).**

**VENDOR NAME:**

(Please enter your company name in this block)

**TYPE OF EQUIPMENT:**

(Make, Model, Size of Loader)

County	Maintenance Building Work Area	Zip Code	HOURLY RATE (with operator)	RESPONSE TIME (How long would it take you to get to the maintenance area after being called?)
St. Louis City			\$	
St. Louis County			\$	
St. Charles			\$	
Jefferson			\$	
Franklin			\$	
			\$	
			\$	
			\$	
			\$	
			\$	
			\$	
			\$	
			\$	
			\$	
			\$	

Provide an hourly rate for Standby Time, payable after call-out, if and when staging of equipment in anticipation of upcoming winter weather is required.	\$
---	----

Provide an hourly rate for Operator Training.	\$
---	----

## PRICING PAGE

### ITEM #3: Dump Trucks

Dump trucks may be needed in order to assist in moving large accumulations of snow. This is bid at an hourly rate (instead of mileage-based) due to variable times and speed associated with use of this equipment in snow removal operations.

Provide the requested information for each piece of equipment you could have available when called upon, for each maintenance area you could provide service in, (you do not need to bid all areas).

Copy this page and submit separate responses if you have multiple pieces of equipment available.

**The hourly rates bid are to include mobilization costs (the cost of getting to and from the work area).**

<b>VENDOR NAME:</b> <small>(Please enter your company name in this block)</small>
--

<b>TYPE OF EQUIPMENT:</b> <small>(Make, Model, Size of Dump Truck )</small>
--

County	Maintenance Building Work Area	Zip Code	HOURLY RATE (with operator)	RESPONSE TIME (How long would it take you to get to the maintenance area after being called?)
St. Louis City			\$	
St. Louis County			\$	
St. Charles			\$	
Jefferson			\$	
Franklin			\$	
			\$	
			\$	
			\$	
			\$	
			\$	
			\$	
			\$	
			\$	
			\$	

Provide an hourly rate for Standby Time, payable after call-out, if and when staging of equipment in anticipation of upcoming winter weather is required.	\$
---	----

Provide an hourly rate for Operator Training.	\$
---	----

## PRICING PAGE

### ITEM #4: Tractor-Trailer Units

Tractor-Trailer Units (Low Boy Trailers) must be provided with all required load securing hardware and accessories (chains, load binders, etc.) for safely transporting MoDOT equipment between work areas.

Provide the requested information for each piece of equipment you could have available when called upon, for each maintenance area you could provide service in, (you do not need to bid all areas).

Copy this page and submit separate responses if you have multiple pieces of equipment available.

**The hourly rates bid are to include mobilization costs (the cost of getting to and from the work area).**

<b>VENDOR NAME:</b> (Please enter your company name in this block)
---

<b>TYPE OF EQUIPMENT:</b> (Make, Model, Size of Tractor-Trailer )
--

County	Maintenance Building Work Area	Zip Code	HOURLY RATE (with operator)	RESPONSE TIME (How long would it take you to get to the maintenance area after being called?)
St. Louis City			\$	
St. Louis County			\$	
St. Charles			\$	
Jefferson			\$	
Franklin			\$	
			\$	
			\$	
			\$	
			\$	
			\$	
			\$	
			\$	
			\$	
			\$	
			\$	

Provide an hourly rate for Standby Time, payable after call-out, if and when staging of equipment in anticipation of upcoming winter weather is required.	\$
---	----

Provide an hourly rate for Operator Training.	\$
---	----

## PRICING PAGE

### ITEM #5: Escort Vehicles

Provide the requested information for each piece of equipment you could have available when called upon, for each maintenance area you could provide service in, (you do not need to bid all areas).

Copy this page and submit separate responses if you have multiple pieces of equipment available.

**The hourly rates bid are to include mobilization costs (the cost of getting to and from the work area).**

**VENDOR NAME:**

(Please enter your company name in this block)

**TYPE OF EQUIPMENT:**

(Make and Model of Escort Vehicle )

County	Maintenance Building Work Area	Zip Code	HOURLY RATE (with operator)	RESPONSE TIME (How long would it take you to get to the maintenance area after being called?)
St. Louis City			\$	
St. Louis County			\$	
St. Charles			\$	
Jefferson			\$	
Franklin			\$	
			\$	
			\$	
			\$	
			\$	
			\$	
			\$	
			\$	
			\$	
			\$	
			\$	

Provide an hourly rate for Standby Time, payable after call-out, if and when staging of equipment in anticipation of upcoming winter weather is required.	\$
---	----

Provide an hourly rate for Operator Training.	\$
---	----

# VENDOR INFORMATION & PREFERENCE CERTIFICATION FORM

## Vendor Information

**All bidders must furnish ALL applicable information requested below**

<b>Vendor Name/Mailing Address:</b>  Email Address:	<b>Vendor Contact Information (including area codes):</b> Phone #: Cellular #: Fax #:
<b>Printed Name of Responsible Officer or Employee:</b>	<b>Signature:</b>
<b>For Corporations - State in which incorporated:</b>	<b>For Others - State of domicile:</b>

If the address listed in the Vendor Name/Mailing Address block above is not located in the State of Missouri, list the address of Missouri offices or places of business:

*If additional space is required, please attach an additional sheet and identify it as **Addresses of Missouri Offices or Places of Business.***

**M/WBE INFORMATION:** List all certified Minority or Women Business Enterprises (**M/WBE**) utilized in the fulfillment of this bid. Include percentages for subcontractors and identify the M/WBE certifying agency:

<u>M/WBE Name</u>	<u>Percentage of Contract</u>	<u>M/WBE Certifying Agency</u>

*If additional space is required, please attach an additional sheet and identify it as **M/WBE Information***

## Preference Certification

**All bidders must furnish ALL applicable information requested below**

**GOODS/PRODUCTS MANUFACTURED OR PRODUCED IN USA:** If any or all of the goods or products offered in the attached bid which the bidder proposes to supply to the MHTC are **not** manufactured or produced in the "United States", or imported in accordance with a qualifying treaty, law, agreement, or regulation, list below, by item or item number, the country other than the United States where each good or product is manufactured or produced.

Item (or item number)	Location Where Item is Manufactured or Produced

*If additional space is required, please attach an additional sheet and identify it as **Location Products are Manufactured or Produced.***

**MISSOURI SERVICE-DISABLED VETERAN BUSINESS:** Please complete the following if applicable. Additional information may be requested if preference is applicable. See below definitions for qualification criteria:

**Service-Disabled Veteran** is defined as any individual who is disabled as certified by the appropriate federal agency responsible for the administration of veterans' affairs.

**Service-Disabled Veteran Business** is defined as a business concern:

- a. Not less than fifty-one (51) percent of which is owned by one or more service-disabled veterans or, in the case of any publicly owned business, not less than fifty-one (51) percent of the stock of which is owned by one or more service-disabled veterans; and
- b. The management and daily business operations of which are controlled by one or more service-disabled veterans.

Veteran Information

Business Information

Service-Disabled Veteran's Name (Please Print)

Service-Disabled Veteran Business Name

Service-Disabled Veteran's Signature

Missouri Address of Service Disabled Veteran Business

## ATTACHMENT ONE - BLADES

The following, from MoDOT Specification MGS-91-01Q, is a schematic showing the measurements of MoDOT's standard carbide-tipped blades, which may be supplied for use on motorgraders (bid item # 1):

- 2 – 12-inch Spaces for 3-foot Blade
- 3 – 12-inch Spaces for 4-foot Blade
- 4 – 12-inch Spaces for 5-foot Blade

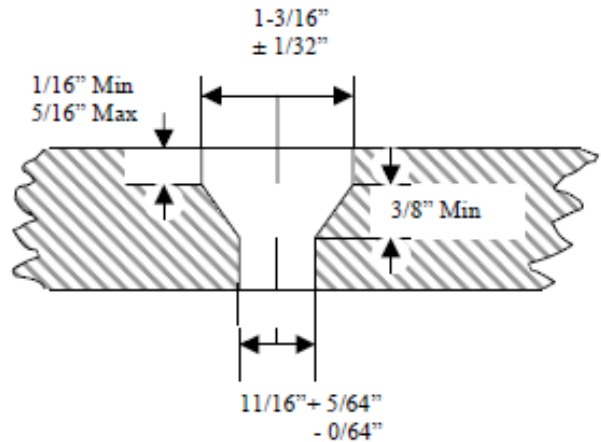
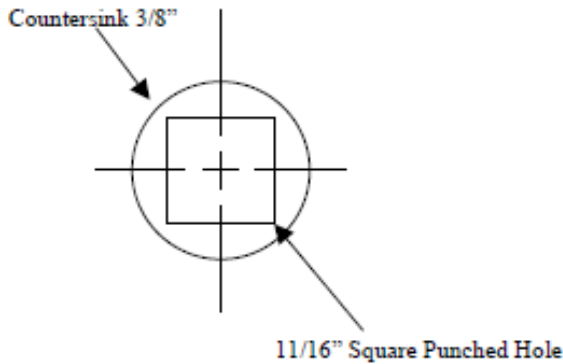
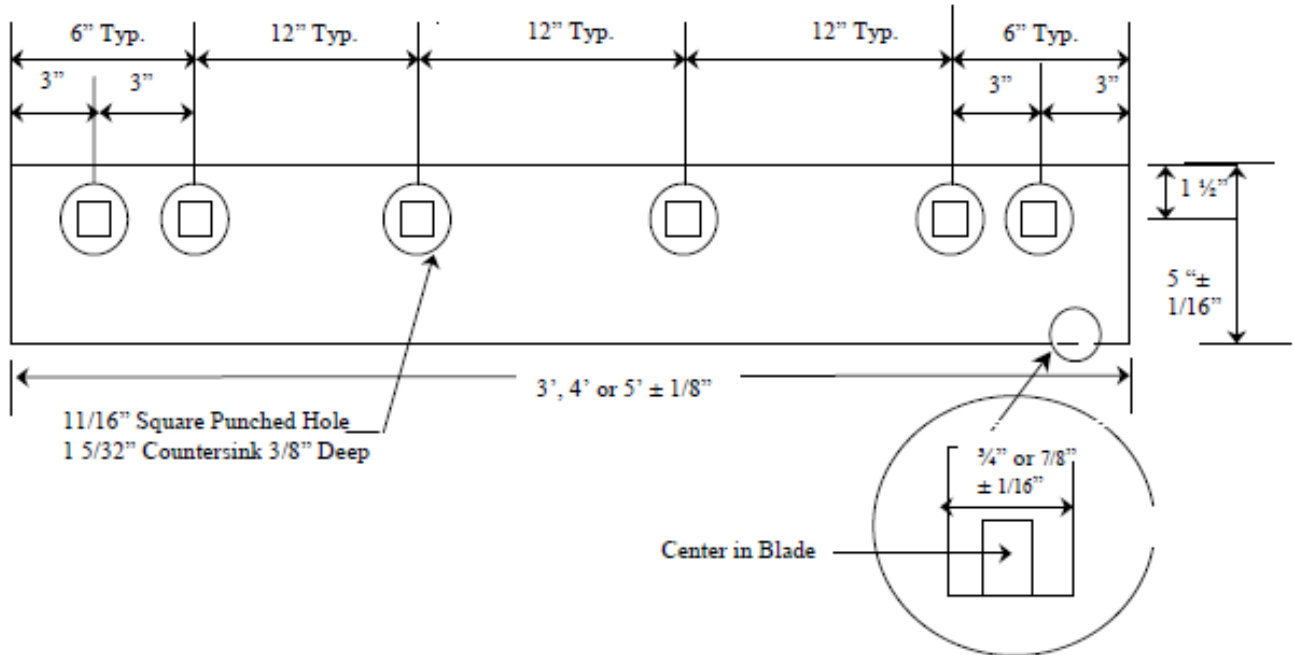

NOTE: This drawing not to scale.  
Follow Dimensions.

**IF NOT SUBMITTING A RESPONSE TO THIS SOLICITATION, PLEASE COMPLETE AND RETURN THIS FORM TO ASSIST PROCUREMENT STAFF IN OUR PROCESS EVALUATIONS AND TO HELP US KEEP OUR VENDOR LISTS UPDATED. THANK YOU.**

## **NO BID**

DATE: \_\_\_\_\_

TO: Missouri Department of Transportation – \_\_\_\_\_ District

\_\_\_\_\_  
\_\_\_\_\_  
\_\_\_\_\_  
\_\_\_\_\_

– fax #

FROM: \_\_\_\_\_ (Company Name)

\_\_\_\_\_ (Contact Person)

\_\_\_\_\_ (Mailing Address)

\_\_\_\_\_ (City, State, Zip Code)

\_\_\_\_\_ (Office Phone #)

\_\_\_\_\_ (Cellular Phone #)

\_\_\_\_\_ (Fax #)

\_\_\_\_\_ (Email Address)

Our company is submitting “NO BID” on Request # \_\_\_\_\_ for the reasons indicated below (check all that apply):

- Product or service is not available or cannot meet the required specifications
- Cannot make required deadline
- The delivery point or work location is outside of our territory or coverage/service area
- Other – Please explain below:

\_\_\_\_\_

- Please keep our name on the bidder’s list for future opportunities on this product or service.
- Please remove our name from your bidder’s list for this product or service.

FAILURE TO RETURN A RESPONSE OR THIS FORM MAY RESULT IN  
REMOVAL FROM OUR VENDOR DATABASE FOR FUTURE OPPORTUNITIES

**This “No Bid” form may be faxed back to 314-301-1437**

**Note: The following pages detail further terms and conditions which apply to this solicitation document. However, it is not necessary to return these pages with your bid submission. If any “Standard Solicitation Provisions” and “General Terms and Conditions” below conflict with any requirements outlined on previous pages, the requirements above take precedence.**

#### **Tax Exempt Status**

The Missouri Highways and Transportation Commission (MHTC) is exempt from paying Missouri Sales Tax, Missouri Use Tax and Federal Excise Tax. However, the Contractor may themselves be responsible for the payment of taxes on materials they purchase to fulfill the contract. A Project Tax Exemption Certificate will be furnished to the successful Bidder upon request, if applicable.

#### **Right of Acceptance/Rejection**

MoDOT reserves the right to reject any or all bids/quotes/proposals, and to accept or reject any items thereon, and to waive technicalities. In case of error in the extension of prices in the solicitation response, unit prices will govern.

#### **General Performance**

This work is to be performed under the general supervision and direction of MoDOT and, if awarded any portion of the work, the Contractor agrees to furnish at his/her own expense all labor and equipment required to complete the work, it being expressly understood that this solicitation is for completed work based upon the price(s) specified according to the scope of work and the requirements and specifications detailed within the solicitation documents.

#### **Invoicing and Payment**

Each invoice should be itemized in accordance with items listed on the purchase order and/or contract. The statewide financial management system has been designed to capture certain receipt and payment information. Therefore, each invoice submitted must reference the purchase order number and must be itemized in accordance with items listed on the purchase order. Failure to comply with this requirement may delay processing of invoices for payment. Unless otherwise provided for in the solicitation documents, payment for all equipment, supplies, and/or services required herein shall be made in arrears. The MHTC shall not make any advance deposits. The MHTC assumes no obligation for equipment, supplies, and/or services shipped or provided in excess of the quantity ordered. Authorized quantity is subject to the MHTC's rejection and shall be returned at the Contractor's expense. The MHTC reserves the right to purchase goods and services using the state-purchasing card.

#### **Inspection and Acceptance**

No equipment, supplies, and/or services received by MoDOT pursuant to a contract shall be deemed accepted until MoDOT has had reasonable opportunity to inspect said equipment, supplies, and/or services. All equipment, supplies, and/or services which do not comply with the specifications and/or requirements or which are otherwise unacceptable or defective may be rejected. In addition, all equipment, supplies, and/or services which are discovered to be defective or which do not conform to any warranty of the Contractor upon inspection (or at any later time if the defects contained were not reasonably ascertainable upon the initial inspection) may be rejected. The MHTC reserves the right to return any such rejected shipment at the Contractor's expense for full credit or replacement and to specify a reasonable date by which replacements must be received. The MHTC's right to reject any unacceptable equipment, supplies, and/or services shall not exclude any other legal, equitable or contractual remedies the MHTC may have.

#### **STANDARD SOLICITATION PROVISIONS**

- a. The solicitation for the procurement of the supplies referenced therein, to which these “Standard Bid Provisions, General Terms and Conditions and Special Terms and Conditions” are attached, is being issued under, and governed by, the provisions of Title 7 – Missouri Department of Transportation, Division 10 – Missouri Highways and Transportation Commission, Chapter 11 – Procurement of Supplies, of the Code of State Regulations. The Missouri Highways and Transportation Commission (MHTC), acting by and through its operating arm, the Missouri Department of Transportation (MoDOT), draws the Bidder's attention to said 7 CSR 10-11 for all the provisions governing solicitation and receipt of bids/quotes and the award of the contract pursuant to this solicitation.
- b. All bids/quotes must be signed with the firm name and by a responsible officer or employee. Obligations assumed by such signature must be fulfilled.

## GENERAL TERMS AND CONDITIONS

### **Definitions**

Capitalized terms as well as other terms used but not defined herein shall have the meaning assigned to them in section 7 CSR 10-11.010 Definition of Terms.

### **Nondiscrimination**

- a. The Contractor shall comply with all state and federal statutes applicable to the Contractor relating to nondiscrimination, including, but not limited to, Chapter 213, RSMo; Title VI and Title VII of Civil Rights Act of 1964 as amended (42 U.S.C. Sections 2000d and 2000e, *et seq.*); and with any provision of the "Americans with Disabilities Act" (42 U.S.C. Section 12101, *et seq.*)
- b. Sanctions for Noncompliance: In the event of the Contractor's noncompliance with the nondiscrimination provisions of this contract, MHTC shall impose such contract sanctions as it or the Federal Highway Administration may determine to be appropriate, including, but not limited to:
  - i. withholding of payments to the Contractor under the contract until the Contractor complies, and/or,
  - ii. cancellation, termination or suspension of the contract, in whole or in part.

### **Contract/Purchase Order**

- a. By submitting a bid/quote, the Bidder agrees to furnish any and all equipment, supplies and/or services specified in the solicitation documents, at the prices quoted, pursuant to all requirements and specifications contained therein.
- b. A binding contract shall consist of: (1) the solicitation documents, amendments thereto, and/or Best and Final Offer (BAFO) request(s) with any changes/additions, (2) the Contractor's bid response, and (3) the MHTC's acceptance of the bid by post-award contract or purchase order.
- c. A notice of award does not constitute an authorization for shipment of equipment or supplies or a directive to proceed with services. Before providing equipment, supplies and/or services, the Contractor must receive a properly authorized notice to proceed and/or purchase order.

### **Applicable Laws and Regulations**

- a. The contract shall be construed according to the laws of the State of Missouri. The Contractor shall comply with all local, state, and federal laws and regulations related to the performance of the contract. The exclusive venue for any legal proceeding relating to or arising, out of the contract shall be in the Circuit Court of Cole County, Missouri.
- b. The Contractor must be registered and maintain good standing with the Secretary of State of the State of Missouri, Missouri Department of Revenue, and other regulatory agencies, as may be required by law or regulations. Prior to the issuance of a purchase order and/or notice to proceed, the Contractor may be required to submit to MHTC a copy of their current Authority Certificate from the Secretary of State of the State of Missouri and/or a copy of their Certificate of No Tax Due from the Missouri Department of Revenue.
- c. Prior to the issuance of a purchase order and/or notice to proceed, all **out-of-state** Contractors providing services within the state of Missouri must submit to MHTC a copy of their current Transient Employer Certificate from the Missouri Department of Revenue, in addition to a copy of their current Authority Certificate from the Secretary of State of the State of Missouri.

### **Executive Order**

The Contractor shall comply with all the provisions of Executive Order 07-13, issued by the Honorable Matt Blunt, Governor of Missouri, on the sixth (6<sup>th</sup>) day of March, 2007. This Executive Order, which promulgates the State of Missouri's position to not tolerate persons who contract with the state engaging in or supporting illegal activities of employing individuals who are not eligible to work in the United States, is incorporated herein by reference and made a part of this Agreement.

- 1) "By signing this Agreement, the Contractor hereby certifies that any employee of the Contractor assigned to perform services under the contract is eligible and authorized to work in the United States in compliance with federal law."
- 2) In the event the Contractor fails to comply with the provisions of the Executive Order 07-13, or in the event the Commission has reasonable cause to believe that the contractor has knowingly employed individuals who are not eligible to work in the United States in violation of federal law, the Commission reserves the right to impose such contract sanctions as it may determine to be appropriate, including but not limited to contract cancellation, termination or suspension in whole or in part or both.
- 3) The Contractor shall include the provisions of this paragraph in every subcontract. The Contractor shall take such action with respect to any subcontract as the Commission may direct as a means of enforcing such provisions, including sanctions for noncompliance.

**Preferences**

- a. In the evaluation of bids/quotes, preferences shall be applied in accordance with 7 CSR 10-11.020(7). Contractors should apply the same preferences in selecting subcontractors. The attached document entitled **“VENDOR INFORMATION AND PREFERENCE CERTIFICATION FORM”** must be completed and returned with the solicitation documents.
- b. Bidders are encouraged to obtain minority business enterprise (MBE) and women business enterprise (WBE) participation in this work through the use of subcontractors, suppliers, joint ventures, or other arrangements that afford meaningful participation for M/WBEs. Bidders are encouraged to obtain 10% MBE and 5% WBE participation.

**Cancellation of Contract**

The MHTC may cancel the Contract at any time for a material breach of contractual obligations or for convenience by providing Contractor with written notice of cancellation. Should the MHTC exercise its right to cancel the contract for such reasons, cancellation will become effective upon the date specified in the notice of cancellation sent to the Contractor.

**Bankruptcy or Insolvency**

Upon filing for any bankruptcy or insolvency proceeding by or against the Contractor, whether voluntarily, or upon the appointment of a receiver, trustee, or assignee, for the benefit of creditors, the Commission reserves the right and sole discretion to either cancel the Agreement or affirm the Agreement and hold the Contractor responsible for damages.

**Warranty**

The Contractor expressly warrants that all equipment, supplies, and/or services provided shall: (1) conform to each and every specification, drawing, sample or other description which was furnished to or adopted by the MHTC, (2) be fit and sufficient for the purpose expressed in the solicitation documents, (3) be merchantable, (4) be of good materials and workmanship, and (5) be free from defect.

**Status of Independent Contractor**

The Contractor represents itself to be an independent Contractor offering such services to the general public and shall not represent itself or its employees to be an employee of the MHTC. Therefore, the Contractor shall assume all legal and financial responsibility for taxes, FICA, employee fringe benefits, workers' compensation, employee insurance, minimum wage requirements, overtime, etc., and agrees to indemnify, save and hold the MHTC, its officers, agents and employees harmless from and against any and all losses (including attorney fees) and damage of any kind related to such matters.

**Non-Waiver**

If one of the parties agrees to waive its right to enforce any term of this Contract, that party does not waive its right to enforce such term at any other time or to enforce any or all other terms of this Contract.

**Indemnification**

The Contractor shall defend, indemnify and hold harmless MHTC, including its members and department employees, from any claim or liability whether based on a claim for damages to real or personal property or to a person for any matter relating to or arising out of the Contractor's performance of its obligations under the contract awarded pursuant to this solicitation.

(T&C's Version May 2011)

**By responding to this RFB, the vendor certifies their company is in compliance with E-Verify requirements and will provide requested documentation upon request, to include a copy of their completed E-Verify Memorandum of Understanding (from the link below) along with a completed Signature and Identity of Bidder form and the appropriate affidavit form from the following pages.**

**Prohibition Of Employment Of Unauthorized Aliens:**

a. Non-employment of Unauthorized Aliens: Pursuant to Section 285.530, RSMo., no business entity or employer shall knowingly employ, hire for employment, or continue to employ an unauthorized alien to perform work within the State of Missouri. As a condition for the award of any contract or grant in excess of five thousand dollars by the State or by any political subdivision of the State to a business entity, or for any business entity receiving a state-administered or subsidized tax credit, tax abatement, or loan from the state, the business entity shall:

1) By sworn affidavit and provision of documentation, affirm its enrollment and participation in a federal work authorization program with respect to the employees working in connection with the contracted services. E-Verify is an example of a federal work authorization program. The business entity must affirm its enrollment and participation in the E-Verify federal work authorization program with respect to the employees proposed to work in connection with the services requested herein by providing acceptable enrollment and participation documentation consisting of **completed** copy of the E-Verify Memorandum of Understanding (MOU). For business entities that are not already enrolled and participating in a federal work authorization program, E-Verify is available at:

[http://www.dhs.gov/files/programs/gc\\_1185221678150.shtm](http://www.dhs.gov/files/programs/gc_1185221678150.shtm)

2) By sworn affidavit, affirm that it does not knowingly employ any person who is an unauthorized alien in connection with the contracted services.

b. Proof of Lawful Presence For Sole Proprietorships and Partnerships: If the business entity is a sole proprietorship or partnership, pursuant to Section 208.009, RSMo., each sole proprietor and each general partner shall provide affirmative proof of lawful presence in the United States. Such sole proprietorship or partnership is eligible for temporary public benefits upon submission by each sole proprietor and general partner of a sworn affidavit of his/her lawful presence on the United States until such lawful presence is affirmatively determined, or as otherwise provided by Section 208.009, RSMo.

**ADDITIONAL INFORMATION FOR VENDORS:**

To begin participation in the federal program takes some time on the internet (at the link above). Once the registration, tutorial and test on this site is passed, an electronically signed Memorandum of Understanding verifying program participation will be given. **Documentation of E-Verify participation will be requested by MoDOT, when applicable. Therefore, it is important that the vendor prints the Memorandum of Understanding (MOU) and keeps a copy for their use in this, as well as future RFB submissions.**

A vendor may submit **EITHER** a page from the E-Verify MOU listing the vendor's name and the MOU signature page completed and signed, at a minimum, by the vendor and Department of Homeland Security

– Verification Division (electronic signature is acceptable) **OR** the E-Verify Employment Eligibility Verification (EEV) page. If the signature page of the MOU lists the vendor name and company ID, then no additional pages of the MOU are required. A vendor can obtain a copy of the EEV page by accessing the vendor’s “Maintain Company” page in E-Verify and printing the screen.





**IF YOUR BUSINESS IS NOT A SOLE-PROPRIETORSHIP OR PARTNERSHIP, THIS AFFIDAVIT FORM SHOULD BE COMPLETED AND RETURNED WITH YOUR RESPONSE TO THIS SOLICITATION.**

**WORKER ELIGIBILITY VERIFICATION AFFIDAVIT FOR ALL MHTC/MODOT CONTRACT AGREEMENTS IN EXCESS OF \$5,000**  
(for joint ventures, a separate affidavit is required for each business entity)

STATE OF \_\_\_\_\_ )  
 ) ss  
COUNTY OF \_\_\_\_\_ )

On this \_\_\_\_\_ day of \_\_\_\_\_, 20\_\_\_\_, before me appeared \_\_\_\_\_, personally known to me or proved to me on the basis of satisfactory evidence to be a person whose name is subscribed to this affidavit, who being by me duly sworn, deposed as follows:

My name is \_\_\_\_\_, and I am of sound mind, capable of making this affidavit, and personally certify the facts herein stated, as required by Section 285.530, RSMo, to enter into any contract agreement with the state to perform any job, task, employment, labor, personal services, or any other activity for which compensation is provided, expected, or due, including but not limited to all activities conducted by business entities:

I am the \_\_\_\_\_ of \_\_\_\_\_, and I am duly authorized, directed, and/or empowered to act officially and properly on behalf of this business entity.  
title business name

I hereby affirm and warrant that the aforementioned business entity is enrolled in a federal work authorization program operated by the United States Department of Homeland Security to verify information of newly hired employees, and the aforementioned business entity shall participate in said program with respect to all employees working in connection to work under the within state contract agreement with the Missouri Highways and Transportation Commission (MHTC). I have attached documentation to this affidavit to evidence enrollment/participation by the aforementioned business entity in a federal work authorization program, as required by Section 285.530, RSMo.

In addition, I hereby affirm and warrant that the aforementioned business entity does not and shall not knowingly employ, in connection to work under the within state contract agreement with MHTC, any alien who does not have the legal right or authorization under federal law to work in the United States, as defined in 8 U.S.C. § 1324a(h)(3).

I am aware and recognize that, unless certain contract and affidavit conditions are satisfied pursuant to Section 285.530, RSMo, the aforementioned business entity may be held liable under Sections 285.525 through 285.550, RSMo, for subcontractors that knowingly employ or continue to employ any unauthorized alien to work within the state of Missouri.

I acknowledge that I am signing this affidavit as a free act and deed of the aforementioned business entity and not under duress.

\_\_\_\_\_  
Affiant Signature

Subscribed and sworn to before me this \_\_\_\_\_ day of \_\_\_\_\_, 20\_\_\_\_.

\_\_\_\_\_  
Notary Public

My commission expires:

*[documentation of enrollment/participation in a federal work authorization program attached]*