

# G/GP-SERIES GRADERS

175–224 kW (235–300 hp)



JOHN DEERE



# So many options, one obvious choice.

Offering one-of-a-kind advantages and unequalled options, our G-Series Graders let you decide how the work gets done. Choose from full-featured Grade Pro (GP) models with state-of-the-art fingertip armrest controls. Or opt for conventional lever-operated machines. No matter which one you choose, both come with a steering wheel. In tandem- or six-wheel-drive configurations. Loaded for bear, or barely loaded, each of these brawny blades comes standard equipped with the same heavy-duty durability and uptime-boosting features including a fluid-efficient PowerTech™ EPA Final Tier 4 (FT4)/EU Stage IV diesel. Easy-access filter bank. And simple-to-clean coolers. That's only the beginning. To learn about the value-added advantages that separate the G-Series from the rest of the pack, read on. Then contact your John Deere dealer for a demo.

Only our graders come standard with John Deere WorkSight™. It combines your machine, our technology, and your dealer to increase uptime and productivity while lowering operating costs. JDLink™ machine monitoring provides real-time machine-utilization and -health data, plus location information. Prognostics proactively suggest maintenance to correct problems early before they create costly downtime. Remote diagnostics enable your dealer to read diagnostic codes, record performance data, and even update software without a trip to the jobsite. Jobsite-optimization solutions include factory- or field-installed grade-control options that make it easy to add your preferred system.

Long-term durability is bolstered by larger-than-usual articulation joint roller bearings, big-displacement wet-sleeve diesel engines, and heavy-duty transmissions, to list just a few.

Production-boosting GP features such as automated cross-slope control and push-button-activated return-to-straight make the most of a seasoned operator's skills. And help improve an inexperienced operator's game.

Fluid-efficient FT4/Stage IV John Deere diesel engines deliver generous displacement, power, and lugging ability.

Choose the operating system that works for you — fingertip armrest or low-effort mechanical controls. Either way, levers are arranged in the familiar industry-standard pattern, and deliver smooth, predictable response.





Key specifications	670G/GP	672G/GP	770G/GP	772G/GP	870G/GP	872G/GP
<b>Net power (FT4/Stage IV)</b>	175 kW (235 hp)	190 kW (255 hp)	190 kW (255 hp)	205 kW (275 hp)	209 kW (280 hp)	224 kW (300 hp)
<b>Net peak torque</b>	1230 Nm (907 lb.-ft.)	1273 Nm (939 lb.-ft.)	1318 Nm (972 lb.-ft.)	1375 Nm (1,014 lb.-ft.)	1428 Nm (1,053 lb.-ft.)	1459 Nm (1,076 lb.-ft.)
<b>Net torque rise</b>	67%	54%	64%	55%	62%	51%
<b>Typical operating weight</b>	19 205 kg (42,340 lb.)	19 976 kg (44,040 lb.)	19 396 kg (42,760 lb.)	20 217 kg (44,570 lb.)	20 303 kg (44,760 lb.)	21 187 kg (46,710 lb.)
<b>Blade pull</b>	12 800 kg (28,220 lb.)	17 587 kg (38,773 lb.)	13 150 kg (28,990 lb.)	17 913 kg (39,491 lb.)	13 299 kg (29,320 lb.)	18 082 kg (39,864 lb.)

# Seeing is believing.

It's easy to see why these graders are becoming industry favorites. Visibility is clearly unsurpassed, with a large expanse of floor-to-ceiling tinted glass, narrow front console, and streamlined saddle arms giving way to a commanding view of the work at hand. What's more, the spacious walk-through cab's many amenities provide all of the fatigue-beating comfort and quiet an operator could ever want. So you can count on the kind of productivity you need.

Which grader's visibility is truly best-in-class? Depends on where you're looking. On ours, you have an unobstructed view of the things you need to see. Like the heel and toe, and back side of the blade. Even the area beneath the front axle is clearly visible, so you can see oncoming obstacles.

We've got your back with large adjustable mirrors that give a clear view of the tandems and ripper.

Standard 15-amp converter (30-amp available) and two 12-volt outlets provide convenient power for cell phones and other electronic devices.

Highly efficient HVAC system employs 13 directional vents for superior all-season comfort. Sliding side glass and available swing-out lower front windows add ventilation.

Storage is generous with numerous overhead compartments, plus a place for a beverage, cooler, cell phone, and other carry-ons.

Push-button-activated cruise control helps reduce operator fatigue. Simply depress the brake or throttle pedals to return to manual operation.

Narrow center console and streamlined saddle bring the blade and front tires within focus. On GP models (shown), control linkages are eliminated and large lower front windows further enhance visibility.

Tinted glass, adjustable front and rear shades, and extended roofline help reduce glare. Standard front and rear intermittent wipers and rear window defogger also help keep the view clear.

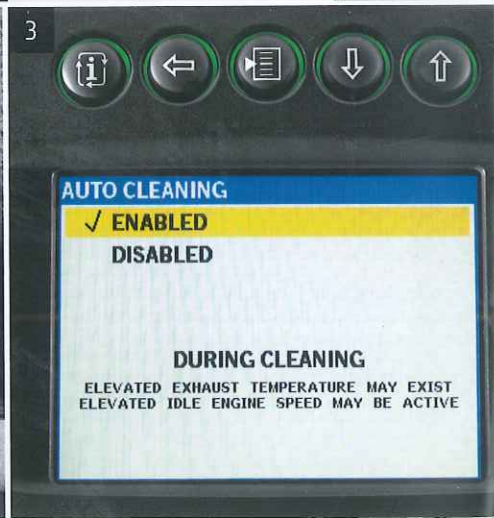
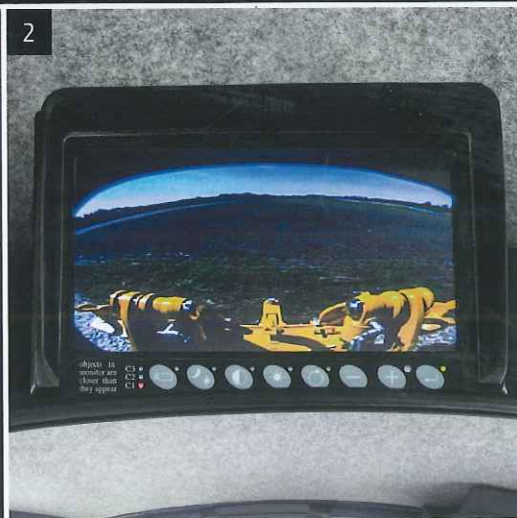

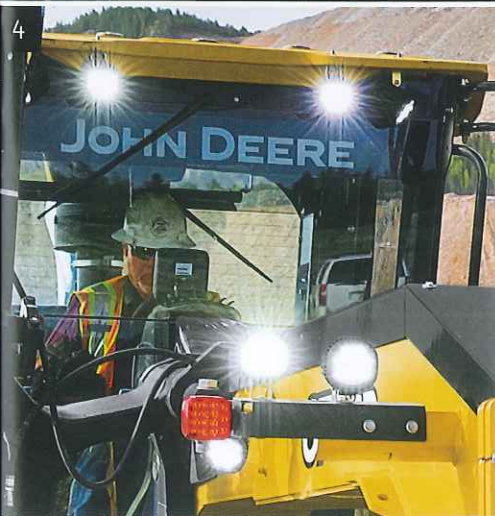

1. Sealed-switch module provides push-button control of 25 machine functions including keyless start. When enabled, keyless start requires a numeric pass code that helps prevent unauthorized machine operation.

2. For an unrestricted rear view, equip your grader with an optional camera. Its dedicated high-resolution color LCD monitor is positioned above the center mirror where it's easy to view.

3. Multi-language LCD monitor gives push-button access to a wealth of machine info including vital and general operating conditions and diagnostic codes. Exhaust filter operation and maintenance status are indicated with on-screen displays.

4. Work before or after daylight? Optional highly durable LED work lights provide optimum illumination to help show the way.

# The genius behind our grader controls.

Armed with input from the people who run them, we set out to design the ideal operating system for our next-generation graders. You talked, we listened, and that's why we offer a choice.

For unsurpassed productivity with a grade-control system, opt for a GP model. Eight armrest-mounted fingertip-actuated controls, including steering lever, are arranged in the industry-standard pattern on each side of the standard steering wheel. Unlike the joysticks used in other graders, your operator won't have to relearn the controls. Or be concerned about unintentionally actuating hydraulic functions when turning, backing up, working on a slope, or V-ditching.

No extra levers required for grade control. Instead, knob-integrated push buttons provide convenient, fingertip activation.

Beyond their predictable operator-friendly controls, GP models come equipped with cross-slope and return-to-straight, and are ready to add the grade-control system of your choice. These and numerous other value-added advantages quickly pay for themselves in increased productivity.

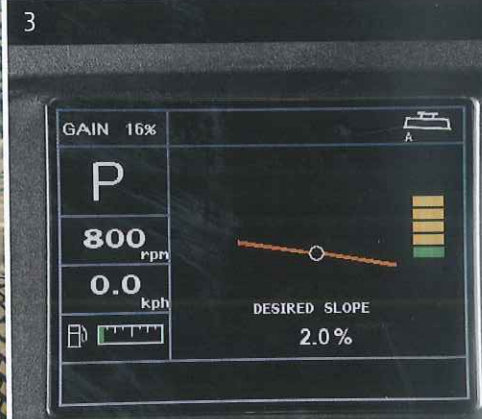
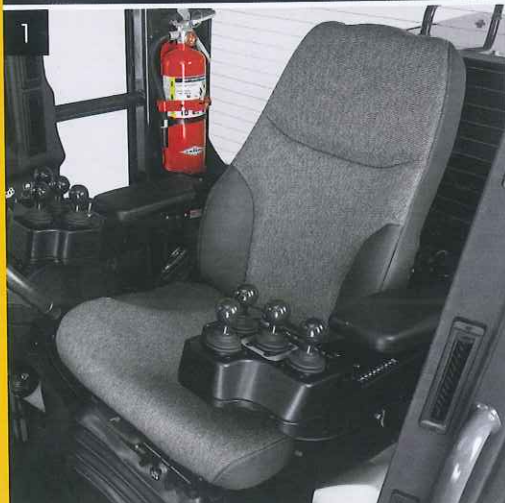



1. With high/wide-back and heated lower cushion, the GP grader's air-suspension seat provides exceptional daylong comfort.
2. Automated cross-slope simplifies holding a consistent slope by reducing operation to a single lever. An operator simply selects the desired slope and the side of the blade that will be manually controlled. Once set, the system automatically adjusts the opposite blade-lift cylinder to maintain the slope. It's a Grade Pro exclusive that helps veteran operators be their best and inexperienced operators get up-to-speed more quickly.
3. Slope-indicator screen can be used as an electronic slope meter. This screen indicates blade position in relation to the desired slope — to help stay on grade.
4. At the touch of a button, return-to-straight automatically straightens an articulated frame. For quicker work cycles.
5. Only John Deere offers you a choice of controls. Our G-Series models come standard equipped with conventional mechanical levers positioned in the industry-accepted pattern and deliver precise, predictable low-effort control. A steering wheel is also included as standard equipment.



4

5



# Levels everything but the playing field.

The G-Series' tall mainframe lets these highly productive graders shoulder larger loads and navigate more easily over obstacles. Provides plenty of clearance for a mid-mount scarifier, and simplifies blade setup and operation, too. You won't find easier-running graders, either. Our exclusive Event-Based Shifting (EBS) transmission delivers smooth-as-silk gear and direction changes, for exceptional control and grading precision without extra effort. There's nothing else like them.





1. Generous throat clearance between the top of the blade and bottom of the circle provides smooth material flow across the blade. Plenty of blade clearance makes it easy to navigate over obstacles, too.
2. Jackscrew-adjusted side-shift wear inserts keep the moldboard tight and precise. Takes only minutes to return tolerances to factory spec.

3. Exclusive ball-and-socket draft-frame pivot and seven-position saddle provide best-in-class blade setup and improved ditch cutting, ditch cleaning, and reach outside the tires.

Our “open-architecture” design lets you employ your favorite brand of grade-control system. GP models come factory equipped with bulkhead connectors, sensor mounts, electrical wiring harnesses, integrated controls, and exclusive universal moldboard mast mounts. So adding a grade-control system is neat, quick, and noninvasive.

For the most seamless grade-control solution, choose between our factory-installed options with a Topcon 3D-MC<sup>2</sup> grade-control system or a Trimble base kit ready to go when you take delivery of your GP Motor Grader.

When engine-stall prevention senses an overload, the system automatically shifts the transmission to neutral, allowing the engine to recover, and issues a visual alert. This John Deere exclusive helps prolong uptime and engine life.

With five true working speeds below 16 km/h (10 mph) and a top speed of 45 km/h (28 mph), it's easy to match ground speed to the work. AutoShift option automatically shifts gears four through eight, for even easier operation.

Optimized moldboard curvature and generous circle torque help keep blades heaped and loads rolling.

Automatic differential lock stays engaged when travelling straight, disengages in turns exceeding 10 deg., and re-engages when returning to straight.

Best-in-class lever efforts are combined with Pressure-Compensated Load-Sensing (PCLS) hydraulics to ensure consistent, predictable, and precise response.

Choose from front scarifier, mid-mount scarifier, or rear scarifier/ripper. There's also a front-lift option that simplifies adding a bulldozer blade or V-plow.

# Nothing runs like a Deere, because nothing is built like one.

Downtime is lost time. Which is why we loaded-up these graders with durability-enhancing advantages that promise to deliver years of trouble-free service. Large-displacement heavy-duty wet-sleeve diesel engines. Larger-than-usual axle shafts, differential locks, hydraulic cylinders, and front axles. Biggest-in-class articulation joint roller bearings. And solid-state electronics and sealed-switch modules, to list just a few. When you know how they're built, you'll run a John Deere.

Standard hydraulically driven cool-on-demand variable-speed reversing fan automatically cycles at operator-selected intervals to eject debris from the radiator and cooler cores. It also slows when the engine is idling to reduce fuel consumption and bystander noise levels.

Exclusive auto shutdown turns off the engine after an operator-determined time of idling. Saves fuel and reduces wear on engine, transmission, and hydraulic components.

Self-adjusting wet-disc brakes are mounted inboard, where they run cool, clean, and unexposed to corrosive materials.

Purpose-built PowerShift™ transmission employs durable heavy-duty clutches and bearings, for reliable performance, shift after shift.

Separate transmission, hydraulic, and axle filtration and cooling systems prevent cross-contamination for longer component life.

John Deere PowerTech FT4/Stage IV diesel engines meet stringent emission regulations without sacrificing power or torque. Plus, they deliver even better total fluid efficiency than the IT4/Stage IIIB engines they replace.





**1.** Sealed-switch module and electrical center employ circuit-board technology that reduces connections from 25 to one, and wires from 100 to four. Solid-state seals and switches keep out moisture and debris, and are proven reliable for more than two million cycles.

**2.** Exclusive heavy-duty dual-drive circle gearbox delivers significantly increased durability in heavy-loaded applications. Standard on 870G/GP and 872G/GP, it's optional on others.

**3.** High-strength circle and draft frame withstand high-impact loads. Available blade-impact system further protects structural components from damage caused by run-ins with obstructions.



# Grounds for a John Deere six-wheel-drive grader.

John Deere tandem-drive graders are plenty productive. But if you want to improve your ground game even more, choose a six-wheel-drive configuration. Putting their entire weight and all six tires to work, their job-proven dual-path hydrostatic drive boosts productivity in all kinds of work. And enables them to accomplish almost everything easier and with fewer passes than their conventional counterparts.



From blue-topping to heavy dirt work, six-wheel-drive G-Series Motor Graders are more productive in all kinds of applications.

Exclusive power-management system balances the demand between the front and rear wheels, delivering smooth six-wheel power.

Six-wheel drive enables these graders to work across steep slopes, carry big loads through corners, and direct the front wheels while ditching without spinning out.

1. Steering system automatically adjusts the speed of the outside front tire while increasing pull to provide full-power turns.

2. If traction and speed are what you need, you get it with a John Deere. All three models deliver six-wheel drive through 7th gear and 32 km/h (20 mph).

3. Power is nothing without control. On our six-wheel-drive graders, the front wheels engage smoothly and in sync with the rear tandems — making them highly adept at finishing.



# Open wide and be awed.

Unlatch the large side panels and you'll discover the many ways these graders minimize maintenance. And help keep daily operating costs low. Our exclusive pivoting coolers and hinged fan provide wide-open access to both sides of the cores for simplified clean-out. Grouped same-side service points make quick work of the daily routine. Easy-to-check sight gauges and fluid reservoirs. Quick-change filters. Convenient fluid-sample ports and advanced self-diagnostics — the G-Series is loaded with time- and money-saving features that help keep maintenance manageable.

1. Available quick fluid-service ports help speed servicing to increase uptime. 500-hour engine oil/filter; 2,000-hour transmission oil/filter, hydraulic filter, and rear axle oil/filter; and 4,000-hour hydraulic and tandem oil-service intervals minimize maintenance.
2. Ground-level fuel and nearby diesel exhaust fluid (DEF) fill access help speed servicing for more uptime. There's also a fast-fuel option available.
3. Maintenance personnel will appreciate the unique easy-access hydraulic, transmission, and differential filter bank.
4. Two-hour replaceable super-tough nylon or bronze draft frame and circle wear inserts minimize maintenance labor.
5. Should a problem arise, easy-to-navigate LCD monitor provides diagnostic info and even offers possible troubleshooting solutions to decrease downtime.





Compare the total cost of fluids, filters, parts, and labor for recommended maintenance and you'll discover the John Deere savings is substantial.

Large service doors open wide, and same-side daily checkpoints are conveniently grouped for easy ground-level access. Standard left-side (and optional right-side) compartment lights illuminate the way.

Available two-position adjustable air cleaner easily adapts to changing applications. Improves air filter performance.

NeverGrease™ is the word for significant savings in operating costs. These no-maintenance pin joints eliminate numerous zerks and the attention they demand.

Most zerks are grouped in banks for quick and easy greasing. Conveniently displayed periodic lube and maintenance chart helps ensure that nothing's overlooked.

Exclusive cooling package eliminates stacked coolers. Together with the hinged swing-out fan, access to the cores is quick and cleaning is easy.

Standard hydraulically driven cool-on-demand variable-speed reversing fan runs only as needed, reducing fuel consumption and wear-causing debris flow through the cores.

Ash-service intervals for the diesel particulate filter (DPF) are condition based and may not be necessary until the first engine overhaul. Machine application, regular maintenance practices, and type of lubrication oil impact intervals.

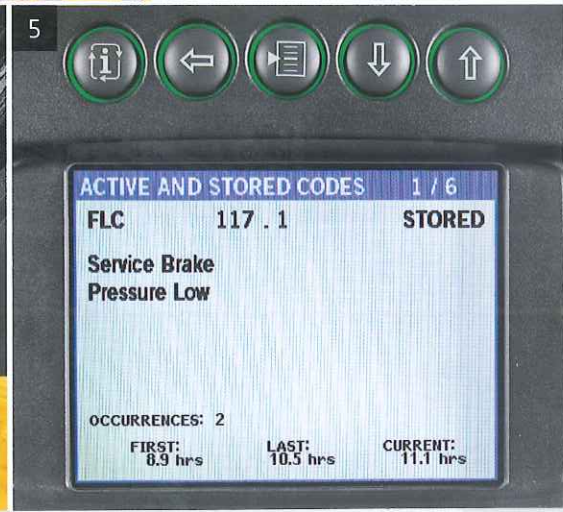
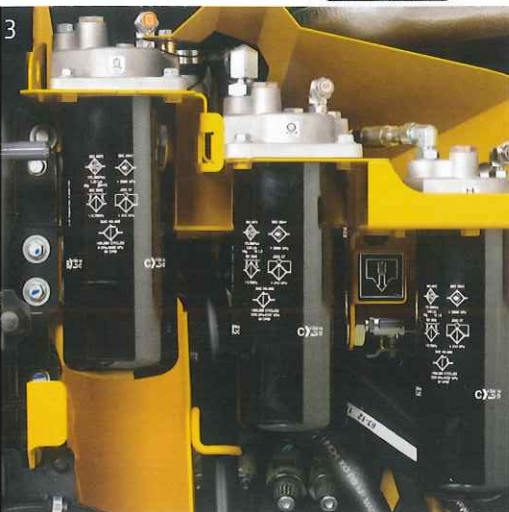

# 670G/GP

Engine	670G/GP			
Manufacturer and Model	John Deere PowerTech™ PSS 9.0L	John Deere PowerTech™ Plus 9.0L	John Deere PowerTech™ Plus 6.8L	John Deere PowerTech™ 6.8L
Non-Road Emissions Standard	EPA Final Tier 4/EU Stage IV	EPA Tier 3/EU Stage IIIA	EPA Tier 3/EU Stage IIIA	EPA Tier 2/EU Stage II
Cylinders	6	6	6	6
Displacement	9.0L (548 cu. in.)	9.0L (548 cu. in.)	6.8L (414 cu. in.)	6.8L (414 cu. in.)
Net Engine Power				
Gear 1	127 kW (170 hp)	118 kW (158 hp)	115 kW (154 hp)	115 kW (154 hp)
Gear 2	138 kW (185 hp)	121 kW (162 hp)	120 kW (161 hp)	120 kW (161 hp)
Gear 3	149 kW (200 hp)	129 kW (173 hp)	129 kW (173 hp)	129 kW (173 hp)
Gear 4	157 kW (210 hp)	138 kW (185 hp)	132 kW (177 hp)	132 kW (177 hp)
Gear 5	160 kW (215 hp)	148 kW (198 hp)	135 kW (181 hp)	135 kW (181 hp)
Gear 6	168 kW (225 hp)	153 kW (205 hp)	138 kW (185 hp)	138 kW (185 hp)
Gear 7	172 kW (230 hp)	153 kW (205 hp)	145 kW (195 hp)	138 kW (185 hp)
Gear 8	175 kW (235 hp)	157 kW (210 hp)	150 kW (202 hp)	138 kW (185 hp)
Net Peak Torque	1230 Nm (907 lb.-ft.)	1124 Nm (829 lb.-ft.)	848 Nm (625 lb.-ft.)	848 Nm (625 lb.-ft.)
Net Torque Rise	67%	77%	30%	45%
Aspiration	Series turbocharged, charge-air cooled	Turbocharged, charge-air cooled		Turbocharged, charge-air cooled
Lubrication	Full-flow spin-on filter and integral cooler	Full-flow spin-on filter and integral cooler		Full-flow spin-on filter and integral cooler
Air Cleaner with Restriction Indicator	Dual element, dry	Dual element, dry	Dual element, dry	Dual element, dry

## Cooling

Cooling-on-demand, hydraulic-driven, variable-speed fan drive to optimize fuel consumption; standard auto-reversing fan to keep coolers clean; swing-out rear fan door and pivoting or foldout coolers for easy cleaning of all cooling components

Engine Coolant, Extended Life, Rating -37 deg. C (-34 deg. F)

## Powertrain

**Transmission** Direct-drive John Deere PowerShift Plus™, modulated shift-on-the-go, Event-Based Shifting (EBS), inching pedal; independent transmission reservoir with separate filtration and cooling system with 117-L/min. (31 gpm) gear pump

Gears	
Forward	8
Reverse	8
<b>Maximum Travel Speeds (forward and reverse)</b>	<i>With no tire slip at 2,180 rpm, 14R24 tires</i>
Gear 1	4.0 km/h (2.5 mph)
Gear 2	5.6 km/h (3.5 mph)
Gear 3	7.7 km/h (4.8 mph)
Gear 4	10.9 km/h (6.8 mph)
Gear 5	16.4 km/h (10.2 mph)
Gear 6	23.2 km/h (14.4 mph)
Gear 7	32.3 km/h (20.1 mph)
Gear 8	45.5 km/h (28.3 mph)
<b>Front Axle</b>	Heavy-duty welded fabrication
Oscillation (total)	32 deg.
Wheel Lean Angle (each direction)	20 deg.
<b>Differentials</b>	Spiral bevel; hydraulically actuated, clutch type can be applied on-the-go; selectable manual or automatic differential lock
<b>Steering</b> (all models include steering wheel)	All-hydraulic power-frame articulation for maneuverability and productivity; crab steering reduces side drift, positions tandems on firm ground, and increases side-slope stability; return-to-straight control included in Grade Pro (GP) option
Turning Radius (front steer and articulation)	7.21 m (23 ft. 8 in.)
Articulation (both right and left)	22 deg.
<b>Final Drives</b>	Inboard-mounted planetary sealed in cooled, filtered oil
<b>Brakes</b>	Foot-controlled, hydraulically operated, multiple wet-disc brakes sealed in pressurized, cooled, filtered oil; both independent systems effective on all 4 tandem wheels
Primary and Secondary Brakes	Hydraulically actuated, inboard of tandem pivot, self-adjusting, sealed in cooled and filtered oil, multi-disc (ISO 3450)
Parking Brake	Automatically spring applied, hydraulically released, oil cooled, self-adjusting (ISO 3450)



#### Hydraulics **670G/GP**

Closed-center, pressure-compensated load-sensing (PCLS), variable-displacement piston pump	
Maximum Pump Flow	212 L/min. (56 gpm)
Maximum System Pressure	18 961 kPa (2,750 psi)
Pump Displacement	90 cm <sup>3</sup> (5.5 cu. in.)

#### Blade Function

All-hydraulic, industry-standard lever placement of blade-function controls; includes float position; 7 discrete saddle positions

#### Blade Range

Lift Above Ground	490 mm (19.3 in.)
Blade Side Shift (right or left)	683 mm (26.9 in.)
Pitch at Ground Line	
Forward	42 deg.
Back	5 deg.
Shoulder Reach Outside Wheels (frame straight, right or left)	2083 mm (6 ft. 10 in.)
Bank Cut Angle (right or left)	90 deg.

#### Productivity

Blade Pull (maximum weight [21 228 kg (46,800 lb.)], 0.9 coefficient of traction)	12 800 kg (28,220 lb.)
---	------------------------

#### Electrical

Solid-state load center and sealed-switch module

Voltage	24 volt
Number of Batteries	2
Battery Capacity	1,400 CCA
Reserve Capacity	440 min.
Amp-Hour Rating	224 amp-hour
Alternator Rating	100 / 130 / 200 amp

**Lights** Driving lights; 2 high- and 2 low-beam halogen headlights; front and rear LED turn signals and marker lights; LED brake and hazard warning lights

#### Mainframe

Type	Welded box construction
Width (minimum)	307 mm (12.1 in.)
Height (minimum)	307 mm (12.1 in.)
Thickness	
Side	16 mm (0.63 in.)
Top and Bottom Plate	23 mm (0.89 in.)
Modulus	
Minimum Vertical Section	1445 cm <sup>3</sup> (88 cu. in.)
Average Vertical Section at Saddle	2245 cm <sup>3</sup> (137 cu. in.)

#### Draft Frame (drawbar)

Welded box construction machined for flatness with double ball-and-socket pivot connection equipped with quick-change replaceable wear inserts

#### Circle

Welded construction, heat-treated, machined for flatness, equipped with quick-change replaceable wear inserts

Circle Diameter	1524 mm (60 in.)
Rotation	360 deg.
Drive	Hydraulic motor and worm gear with positive lock
Circle Side Shift (right and left)	787 mm (31 in.)

#### Moldboard

High-strength, pre-stressed for higher strength, wear-resistant, high-carbon steel and reversible end bits; blade side-shift wear system includes quick-change replaceable wear inserts and quick-adjust jackscrew system

Base Length	3.66 m (12 ft. 0 in.)
Height (measured along arc, including cutting edge)	610 mm (24 in.)
Thickness	22 mm (0.88 in.)

<b>Cutting Edge</b>		<b>670G/GP</b>
Dura-Max™ through-hardened steel edge		
Thickness	16 mm (0.62 in.)	
Width	152 mm (6 in.)	
<b>Scarifiers</b>		
	<i>Front</i>	<i>Mid-mount</i>
Type	Parallel-linkage V-type toolbar with manual 2-pitch positions, with hydraulic float	Radial linkage, with NeverGrease™ pin joints; V-type toolbar with manual 3-pitch positions, with hydraulic float
Width of Cut	1.20 m (4 ft. 0 in.)	1.19 m (3 ft. 11 in.)
Number of Shanks/Teeth	5 (maximum capacity 9)	11
Lift Above Ground	589 mm (23.2 in.)	335 mm (13.2 in.)
Maximum Penetration	335 mm (13.2 in.)	325 mm (12.8 in.)
Shank		
Spacing	146 mm (5.75 in.)	117 mm (4.6 in.)
Size	25 x 76 mm (1 x 3 in.)	25 x 76 mm (1 x 3 in.)
<b>Front Lift Group (Balderson-style)</b>		
Parallel linkage, mechanical pins, and hydraulic float		
Lift		
Above Ground (top of tube)	1864 mm (73.4 in.)	
Range	988 mm (38.9 in.)	
<b>Rear Ripper/Scarifier</b>		
Parallel linkage, with NeverGrease pin joints, hydraulic float, and integrated hitch		
	<i>Ripper</i>	<i>Scarifier</i>
Width of Cut	2.21 m (7 ft. 3 in.)	2.18 m (7 ft. 2 in.)
Number of Shanks/Teeth	3 (maximum capacity 5)	None standard (maximum capacity 9)
Lift Above Ground	602 mm (23.7 in.)	810 mm (31.9 in.)
Maximum Penetration	426 mm (16.8 in.)	323 mm (12.7 in.)
Shank Size	61.5 x 133 mm (2.42 x 5.25 in.)	25 x 76 mm (1 x 3 in.)
<b>Operator Station</b>		
Low-profile cab with ROPS (ISO 3471-2008) and FOPS (ISO 3449-2005)		
<b>Tires/Wheels</b>		
	<i>14R24 on 254-mm (10 in.) Rim</i>	<i>17.5R25 on 356-mm (14 in.) Rim</i>
Overall Width	2.49 m (98 in.)	2.64 m (104 in.)
Ground Clearance (front axle)	587 mm (23.1 in.)	587 mm (23.1 in.)
<b>Serviceability</b>		
<b>Refill Capacities</b>	<i>EPA Final Tier 4/EU Stage IV</i>	<i>EPA Tier 3/EU Stage IIIA and EPA Tier 2/EU Stage II</i>
Fuel Tank	416.5 L (110 gal.)	416.5 L (110 gal.)
Diesel Exhaust Fluid (DEF) Tank	22.5 L (6 gal.)	—
Cooling System		
6.8L Engine	—	44.0 L (11.6 gal.)
9.0L Engine	55.0 L (14.5 gal.)	48.5 L (12.8 gal.)
Engine Oil with Filter		
6.8L Engine	—	26.0 L (6.9 gal.)
9.0L Engine	27.0 L (7.1 gal.)	27.0 L (7.1 gal.)
Transmission Fluid	28.4 L (7.5 gal.)	28.4 L (7.5 gal.)
Differential Housing	38.0 L (10 gal.)	38.0 L (10 gal.)
Tandem Housings (each)	74.0 L (19.5 gal.)	74.0 L (19.5 gal.)
Circle Gearbox	5.7 L (1.5 gal.)	5.7 L (1.5 gal.)
Hydraulic Reservoir	60.5 L (16 gal.)	53.0 L (14 gal.)
<b>Operating Weights</b>		
With Full Fuel Tank, 3.66-m x 610-mm x 22-mm (12 ft. x 24 in. x 0.88 in.) Moldboards with 152-mm x 16-mm (6 in. x 5/8 in.) Cutting Edges, 14R24 Bias L2 Tires, and 79-kg (175 lb.)		
Operator	<i>EPA Final Tier 4/EU Stage IV</i>	<i>EPA Tier 3/EU Stage IIIA and EPA Tier 2/EU Stage II</i>
Front	4178 kg (9,210 lb.)	4191 kg (9,240 lb.)
Rear	11 798 kg (26,010 lb.)	11 149 kg (24,580 lb.)
Total	15 976 kg (35,220 lb.)	15 340 kg (33,820 lb.)
Typical Operating Weight with Front Push Block, Rear Ripper/Scarifier, and Other Equipment		
Front	5507 kg (12,140 lb.)	5479 kg (12,080 lb.)
Rear	13 698 kg (30,200 lb.)	12 887 kg (28,410 lb.)
Total	19 205 kg (42,340 lb.)	18 366 kg (40,490 lb.)
Maximum Operating Weight	21 228 kg (46,800 lb.)	21 228 kg (46,800 lb.)

Option Weights	670G/GP
Moldboards with Through-Hardened Dura-Max Cutting Edge	
3.66 m x 610 mm x 22 mm (12 ft. x 24 in. x 7/8 in.) with 152-mm x 16-mm (6 in. x 5/8 in.) cutting edge and 16-mm (5/8 in.) hardware	0 kg (0 lb.)
3.66 m x 610 mm x 22 mm (12 ft. x 24 in. x 7/8 in.) with 203-mm x 19-mm (8 in. x 3/4 in.) cutting edge and 16-mm (5/8 in.) hardware	45 kg (99 lb.)
3.66 m x 686 mm x 25 mm (12 ft. x 27 in. x 1 in.) with 203-mm x 19-mm (8 in. x 3/4 in.) cutting edge and 16-mm (5/8 in.) hardware	126 kg (277 lb.)
3.96 m x 686 mm x 25 mm (13 ft. x 27 in. x 1 in.) with 203-mm x 19-mm (8 in. x 3/4 in.) cutting edge and 16-mm (5/8 in.) hardware	180 kg (396 lb.)
4.27 m x 610 mm x 22 mm (14 ft. x 24 in. x 7/8 in.) with 152-mm x 16-mm (6 in. x 5/8 in.) cutting edge and 16-mm (5/8 in.) hardware	105 kg (231 lb.)
4.27 m x 610 mm x 22 mm (14 ft. x 24 in. x 7/8 in.) with 203-mm x 19-mm (8 in. x 3/4 in.) cutting edge and 16-mm (5/8 in.) hardware	157.4 kg (347 lb.)
4.27 m x 686 mm x 25 mm (14 ft. x 27 in. x 1 in.) with 203-mm x 19-mm (8 in. x 3/4 in.) cutting edge and 16-mm (5/8 in.) hardware	251.3 kg (554 lb.)
Extensions, 610 mm (2 ft.) (right or left)	
For Use with 610-mm (24 in.) Moldboards	115.7 kg (255 lb.)
For Use with 686-mm (27 in.) Moldboards	120.2 kg (265 lb.)
Overlay End Bits, Reversible (one pair)	
For 152-mm (6 in.) Cutting Edge	19.5 kg (43 lb.)
For 203-mm (8 in.) Cutting Edge	23.1 kg (51 lb.)
Heavy-Duty Dual-Input Circle-Drive Gearbox	14 kg (31 lb.)
Circle-Drive Slip Clutch	9.1 kg (20 lb.)
Moldboard Impact-Absorption System	43.1 kg (95 lb.)
Ripper/Scarifier, Rear Mounted with Hitch and Ripper Shanks (3)	1139 kg (2,510 lb.)
Scarifier Shanks with Teeth (9 for rear ripper/scarifier)	68 kg (150 lb.)
Ripper Shanks and Teeth (2)	63 kg (139 lb.)
Rear Counterweight with Integral Rear Hitch	727.1 kg (1,603 lb.)
Rear Hitch	54.4 kg (120 lb.)
Push Block, Front	1338 kg (2,950 lb.)
Scarifier	
Front Mount with Teeth (5)	831.4 kg (1,833 lb.)

Machine Dimensions	
A Height to Top of Cab	3.18 m (10 ft. 5 in.)
A <sup>I</sup> Height to Top of Full-Height Cab	3.40 m (11 ft. 2 in.)
B Height to Top of Exhaust (9.0L engine)	3.10 m (10 ft. 2 in.)
C Height to Top of Blade-Lift Cylinders	3.05 m (10 ft. 0 in.)
D Tandem Axle Spacing	1.54 m (5 ft. 1 in.)
E Blade Base	2.57 m (8 ft. 5 in.)

Option Weights (continued)	670G/GP
Scarifier (continued)	
Mid-Mount with Teeth (11)	1481 kg (3,265 lb.)
Front Lift Group (Balderson-style)	762.9 kg (1,682 lb.)
Dozer Blade, Front Mounted	
2464 mm x 955 mm (97 in. x 37.6 in.)	519 kg (1,146 lb.)
2667 mm x 955 mm (105 in. x 37.6 in.)	590 kg (1,301 lb.)
Tires	
14.00-24, 12 PR G2	0 kg (0 lb.)
17.5-25, 12 PR G2/L2	114.3 kg (252 lb.)
14.00-R24, Radial, G2/L2 General Purpose	220.4 kg (486 lb.)
14.00-R24, Radial, G2/L2 Snow	261.3 kg (576 lb.)
17.5-R25, Radial, L2 General Purpose	272.2 kg (600 lb.)
17.5-R25, Radial, G2/L2 Snow	315.7 kg (696 lb.)
17.5-R25, Radial, G3/L3 General Purpose	362.0 kg (798 lb.)
One-Piece Rims	
229 mm x 610 mm (9 in. x 24 in.)	0 kg (0 lb.)
330 mm x 635 mm (13 in. x 25 in.)	65.3 kg (144 lb.)
Multi-Piece Rims	
254 mm x 610 mm (10 in. x 24 in.)	179.6 kg (396 lb.)
356 mm x 635 mm (14 in. x 25 in.)	266.7 kg (588 lb.)
Fenders	
Front	76.7 kg (169 lb.)
Rear	140.6 kg (310 lb.)
Cab, Low with Opening Front and Side Windows	14.5 kg (32 lb.)
Premium Air-Suspension, Heated Seat with Adjustable Arm- and Headrests	12.7 kg (28 lb.)
Fast-Fill Fuel System	13.6 kg (30 lb.)
Quick Service	10.9 kg (24 lb.)
Sound-Absorption Package (machines equipped with Tier 3/Stage IIIA and Tier 2/Stage II engines only)	14.1 kg (31 lb.)
Secondary Steering	26.3 kg (58 lb.)
Beacon Bracket	8.2 kg (18 lb.)
Fire Extinguisher	14.5 kg (32 lb.)
Lighting Packages	
10 Halogen Lights	4.5 kg (10 lb.)
16 Halogen Lights	7.3 kg (16 lb.)
18 Halogen and/or LED Lights	8.2 kg (18 lb.)
High-Front Light Bar for Snowplowing	20 kg (44 lb.)
Auxiliary Hydraulic Control Valve Section and Controls	6.8 kg (15 lb.)
Hydraulics for Front-Mounted Equipment	8.6 kg (19 lb.)

Machine Dimensions (continued)	
F Wheelbase	6.16 m (20 ft. 3 in.)
G Overall Length	8.89 m (29 ft. 2 in.)
H Overall Length with Scarifier	9.69 m (31 ft. 9 in.)
I Overall Length with Push Block and Ripper	9.99 m (32 ft. 9 in.)
I <sup>I</sup> Overall Length with Scarifier and Ripper	10.59 m (34 ft. 9 in.)

For Overall Width see Tires/Wheels on page 18.

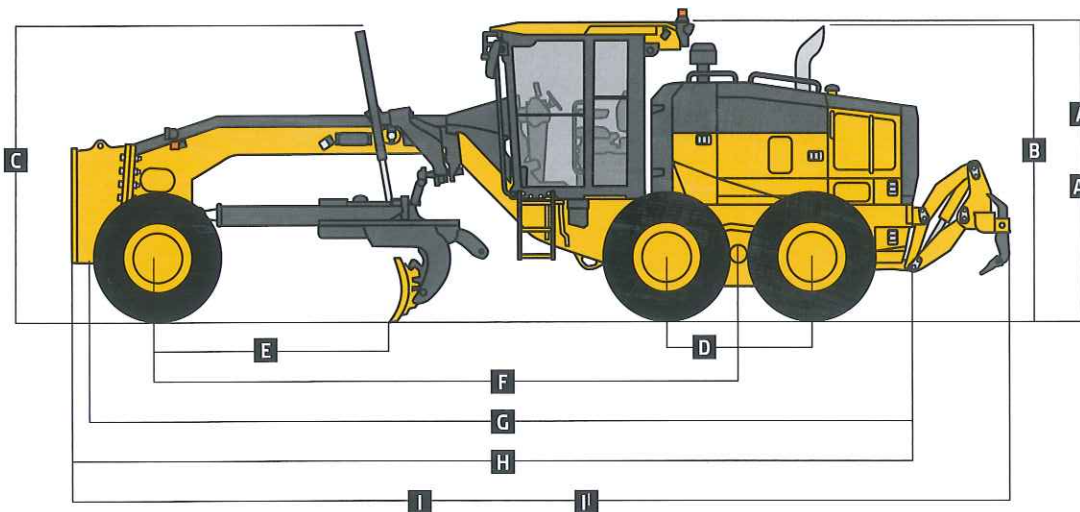

# 672G/GP



Engine	672G/GP			
Manufacturer and Model	John Deere PowerTech™ PSS 9.0L	John Deere PowerTech™ Plus 9.0L	John Deere PowerTech™ Plus 6.8L	John Deere PowerTech™ 6.8L
Non-Road Emissions Standard	EPA Final Tier 4/EU Stage IV	EPA Tier 3/EU Stage IIIA	EPA Tier 3/EU Stage IIIA	EPA Tier 2/EU Stage II
Cylinders	6	6	6	6
Displacement	9.0L (548 cu. in.)	9.0L (548 cu. in.)	6.8L (414 cu. in.)	6.8L (414 cu. in.)
Net Engine Power				
Gear 1 (6WD on)	142 kW (190 hp)	129 kW (173 hp)	129 kW (173 hp)	129 kW (173 hp)
Gear 2 (6WD on)	153 kW (205 hp)	132 kW (177 hp)	132 kW (177 hp)	132 kW (177 hp)
Gear 3 (6WD on)	164 kW (220 hp)	140 kW (188 hp)	135 kW (181 hp)	135 kW (181 hp)
Gear 4 (6WD on)	172 kW (230 hp)	149 kW (200 hp)	136 kW (182 hp)	136 kW (182 hp)
Gear 5 (6WD on)*	175 kW (235 hp)	157 kW (210 hp)	135 kW (181 hp)	135 kW (181 hp)
Gear 6 (6WD on)*	183 kW (245 hp)	163 kW (218 hp)	138 kW (185 hp)	138 kW (185 hp)
Gear 7 (6WD on)*	190 kW (255 hp)	163 kW (218 hp)	145 kW (195 hp)	138 kW (185 hp)
Gear 8	183 kW (245 hp)	164 kW (220 hp)	150 kW (202 hp)	138 kW (185 hp)
Net Peak Torque	1273 Nm (939 lb.-ft.)	1152 Nm (850 lb.-ft.)	848 Nm (625 lb.-ft.)	848 Nm (625 lb.-ft.)
Net Torque Rise	54%	72%	30%	45%
Aspiration	Series turbocharged, charge-air cooled	Turbocharged, charge-air cooled		Turbocharged, charge-air cooled
Lubrication	Full-flow spin-on filter and integral cooler	Full-flow spin-on filter and integral cooler		Full-flow spin-on filter and integral cooler
Air Cleaner with Restriction Indicator	Dual element, dry	Dual element, dry	Dual element, dry	Dual element, dry

\*6WD is active in gears 1–7 only on machines equipped with FT4/Stage IV engines. 6WD is active in gears 1–4 on machines equipped with Tier 3/Stage IIIA and Tier 2/Stage II engines.

## Cooling

Cooling-on-demand, hydraulic-driven, variable-speed fan drive to optimize fuel consumption; standard auto-reversing fan to keep coolers clean; swing-out rear fan door and pivoting or foldout coolers for easy cleaning of all cooling components

Engine Coolant, Extended Life, Rating –37 deg. C (–34 deg. F)

## Powertrain

### 6-Wheel Drive

Automatic dual-path hydrostatic drive; increases tractive effort and front-end control; includes separate left and right systems with variable-displacement pumps, axial-piston wheel motors, and freewheel at transport speeds; operator-selectable 15-position rotary aggressiveness control and inching capability down to 0 mph; precision mode (propelled by front wheels only)

6-Wheel-Drive Effective Gears 1–7 forward and reverse (IT4/Stage IIIB engine only) / 1–4 forward and reverse (Tier 3/Stage IIIA and Tier 2/Stage II engines)

### Precision Mode

Effective Gears 1–3 forward only  
Operating Speeds 0.4–8.0 km/h (0.25–5.0 mph)

Hydrostatic Pumps (2 each) 64 cm<sup>3</sup> (3.9 cu. in.)

Wheel Motors 60 cm<sup>3</sup> (3.7 cu. in.)

Final Reduction 38.7:1

### Transmission

Direct-drive John Deere PowerShift Plus™, modulated shift-on-the-go, Event-Based Shifting (EBS), inching pedal; independent transmission reservoir with separate filtration and cooling system with 117-L/min. (31 gpm) gear pump

### Gears

Forward 8

Reverse 8

Maximum Travel Speeds (forward and reverse) *With no tire slip at 2,180 rpm, 14R24 tires*

Gear 1 4.0 km/h (2.5 mph)

Gear 2 5.6 km/h (3.5 mph)

Gear 3 7.7 km/h (4.8 mph)

Gear 4 10.9 km/h (6.8 mph)

Gear 5 16.4 km/h (10.2 mph)

Gear 6 23.2 km/h (14.4 mph)

Gear 7 32.3 km/h (20.1 mph)

Gear 8 45.5 km/h (28.3 mph)

### Front Axle

Heavy-duty welded fabrication

Oscillation (total) 32 deg.

Wheel Lean Angle (each direction) 20 deg.

### Differentials

Spiral bevel; hydraulically actuated, clutch type can be applied on-the-go; selectable manual or automatic differential lock

Steering (all models include steering wheel) All-hydraulic power-frame articulation for maneuverability and productivity; crab steering reduces side drift, positions tandems on firm ground, and increases side-slope stability; return-to-straight control included in Grade Pro (GP) option

Turning Radius (front steer and articulation) 7.21 m (23 ft. 8 in.)

Articulation (both right and left) 22 deg.



<b>Powertrain (continued)</b>	<b>672G/GP</b>
<b>Final Drives</b>	Inboard-mounted planetary sealed in cooled, filtered oil
<b>Brakes</b>	Foot-controlled, hydraulically operated, multiple wet-disc brakes sealed in pressurized, cooled, filtered oil; both independent systems effective on all 4 tandem wheels
Primary and Secondary Brakes	Hydraulically actuated, inboard of tandem pivot, self-adjusting, sealed in cooled and filtered oil, multi-disc (ISO 3450)
Parking Brake	Automatically spring applied, hydraulically released, oil cooled, self-adjusting (ISO 3450)
<b>Hydraulics</b>	
Closed-center, pressure-compensated load-sensing (PCLS), variable-displacement piston pump	
Maximum Pump Flow	212 L/min. (56 gpm)
Maximum System Pressure	18 961 kPa (2,750 psi)
Pump Displacement	90 cm <sup>3</sup> (5.5 cu. in.)
<b>Blade Function</b>	
All-hydraulic, industry-standard lever placement of blade-function controls; includes float position; 7 discrete saddle positions	
<b>Blade Range</b>	
Lift Above Ground	490 mm (19.3 in.)
Blade Side Shift (right or left)	683 mm (26.9 in.)
Pitch at Ground Line	
Forward	42 deg.
Back	5 deg.
Shoulder Reach Outside Wheels (frame straight, right or left)	2083 mm (6 ft. 10 in.)
Bank Cut Angle (right or left)	90 deg.
<b>Productivity</b>	
Blade Pull (maximum weight [21 228 kg (46,800 lb.)], 0.9 coefficient of traction)	17 587 kg (38,773 lb.)
<b>Electrical</b>	
Solid-state load center and sealed-switch module	
Voltage	24 volt
Number of Batteries	2
Battery Capacity	1,400 CCA
Reserve Capacity	440 min.
Amp-Hour Rating	224 amp-hour
Alternator Rating	100 / 130 / 200 amp
<b>Lights</b>	Driving lights; 2 high- and 2 low-beam halogen headlights; front and rear LED turn signals and marker lights; LED brake and hazard warning lights
<b>Mainframe</b>	
Type	Welded box construction
Width (minimum)	307 mm (12.1 in.)
Height (minimum)	307 mm (12.1 in.)
Thickness	
Side	16 mm (0.63 in.)
Top and Bottom Plate	23 mm (0.89 in.)
Modulus	
Minimum Vertical Section	1445 cm <sup>3</sup> (88 cu. in.)
Average Vertical Section at Saddle	2245 cm <sup>3</sup> (137 cu. in.)
<b>Draft Frame (drawbar)</b>	
Welded box construction machined for flatness with double ball-and-socket pivot connection equipped with quick-change replaceable wear inserts	
<b>Circle</b>	
Welded construction, heat-treated, machined for flatness, equipped with quick-change replaceable wear inserts	
Circle Diameter	1524 mm (60 in.)
Rotation	360 deg.
Drive	Hydraulic motor and worm gear with positive lock
Circle Side Shift (right and left)	787 mm (31 in.)
<b>Moldboard</b>	
High-strength, pre-stressed for higher strength, wear-resistant, high-carbon steel and reversible end bits; blade side-shift wear system includes quick-change replaceable wear inserts and quick-adjust jackscrew system	
Base Length	3.66 m (12 ft. 0 in.)
Height (measured along arc, including cutting edge)	610 mm (24 in.)
Thickness	22 mm (0.88 in.)

**Cutting Edge** 672G/GP

Dura-Max™ through-hardened steel edge

Thickness 16 mm (0.62 in.)

Width 152 mm (6 in.)

**Scarifiers**

	<i>Front</i>	<i>Mid-mount</i>
Type	Parallel-linkage V-type toolbar with manual 2-pitch positions, with hydraulic float	Radial linkage, with NeverGrease™ pin joints; V-type toolbar with manual 3-pitch positions, with hydraulic float
Width of Cut	1.20 m (4 ft. 0 in.)	1.19 m (3 ft. 11 in.)
Number of Shanks/Teeth	5 (maximum capacity 9)	11
Lift Above Ground	589 mm (23.2 in.)	335 mm (13.2 in.)
Maximum Penetration	335 mm (13.2 in.)	325 mm (12.8 in.)
Shank		
Spacing	146 mm (5.75 in.)	117 mm (4.6 in.)
Size	25 x 76 mm (1 x 3 in.)	25 x 76 mm (1 x 3 in.)

**Front Lift Group (Balderson-style)**

Parallel linkage, mechanical pins, and hydraulic float

**Lift**

Above Ground (top of tube) 1864 mm (73.4 in.)

Range 988 mm (38.9 in.)

**Rear Ripper/Scarifier**

Parallel linkage, with NeverGrease pin joints, hydraulic float, and integrated hitch

	<i>Ripper</i>	<i>Scarifier</i>
Width of Cut	2.21 m (7 ft. 3 in.)	2.18 m (7 ft. 2 in.)
Number of Shanks/Teeth	3 (maximum capacity 5)	None standard (maximum capacity 9)
Lift Above Ground	602 mm (23.7 in.)	810 mm (31.9 in.)
Maximum Penetration	426 mm (16.8 in.)	323 mm (12.7 in.)
Shank Size	61.5 x 133 mm (2.42 x 5.25 in.)	25 x 76 mm (1 x 3 in.)

**Operator Station**

Low-profile cab with ROPS (ISO 3471-2008) and FOPS (ISO 3449-2005)

**Tires/Wheels**

	<i>14R24 on 254-mm (10 in.) Rim</i>	<i>17.5R25 on 356-mm (14 in.) Rim</i>
Overall Width	2.49 m (98 in.)	2.64 m (104 in.)
Ground Clearance (front axle)	587 mm (23.1 in.)	587 mm (23.1 in.)

**Serviceability**

<b>Refill Capacities</b>	<i>EPA Final Tier 4/EU Stage IV</i>	<i>EPA Tier 3/EU Stage IIIA and EPA Tier 2/EU Stage II</i>
Fuel Tank	416.5 L (110 gal.)	416.5 L (110 gal.)
Diesel Exhaust Fluid (DEF) Tank	22.5 L (6 gal.)	—
Cooling System		
6.8L Engine	—	44.0 L (11.6 gal.)
9.0L Engine	55.0 L (14.5 gal.)	48.5 L (12.8 gal.)
Engine Oil with Filter		
6.8L Engine	—	26.0 L (6.9 gal.)
9.0L Engine	27.0 L (7.1 gal.)	27.0 L (7.1 gal.)
Transmission Fluid	28.4 L (7.5 gal.)	28.4 L (7.5 gal.)
Differential Housing	38.0 L (10 gal.)	38.0 L (10 gal.)
Tandem Housings (each)	74.0 L (19.5 gal.)	74.0 L (19.5 gal.)
Circle Gearbox	5.7 L (1.5 gal.)	5.7 L (1.5 gal.)
Hydraulic Reservoir	60.5 L (16 gal.)	53.0 L (14 gal.)

**Operating Weights**

With Full Fuel Tank, 3.66-m x 610-mm x 22-mm (12 ft. x 24 in. x 0.88 in.) Moldboards with 152-mm x 16-mm (6 in. x 5/8 in.) Cutting Edges, 14R24 L2 Tires, and 79-kg (175 lb.)

Operator	<i>EPA Final Tier 4/EU Stage IV</i>	<i>EPA Tier 3/EU Stage IIIA and EPA Tier 2/EU Stage II</i>
Front	4781 kg (10,540 lb.)	4790 kg (10,560 lb.)
Rear	12 215 kg (26,930 lb.)	11 567 kg (25,500 lb.)
Total	16 996 kg (37,470 lb.)	16 357 kg (36,060 lb.)

Typical Operating Weight with Front Push Block, Rear Ripper/Scarifier, and Other Equipment

Front	6001 kg (13,230 lb.)	5974 kg (13,170 lb.)
Rear	13 975 kg (30,810 lb.)	13 163 kg (29,020 lb.)
Total	19 976 kg (44,040 lb.)	19 137 kg (42,190 lb.)
Maximum Operating Weight	21 228 kg (46,800 lb.)	21 228 kg (46,800 lb.)

Option Weights	672G/GP
<b>Moldboards with Through-Hardened Dura-Max Cutting Edge</b>	
3.66 m x 610 mm x 22 mm (12 ft. x 24 in. x 7/8 in.) with 152-mm x 16-mm (6 in. x 5/8 in.) cutting edge and 16-mm (5/8 in.) hardware	0 kg (0 lb.)
3.66 m x 610 mm x 22 mm (12 ft. x 24 in. x 7/8 in.) with 203-mm x 19-mm (8 in. x 3/4 in.) cutting edge and 16-mm (5/8 in.) hardware	45 kg (99 lb.)
3.66 m x 686 mm x 25 mm (12 ft. x 27 in. x 1 in.) with 203-mm x 19-mm (8 in. x 3/4 in.) cutting edge and 16-mm (5/8 in.) hardware	126 kg (277 lb.)
3.96 m x 686 mm x 25 mm (13 ft. x 27 in. x 1 in.) with 203-mm x 19-mm (8 in. x 3/4 in.) cutting edge and 16-mm (5/8 in.) hardware	180 kg (396 lb.)
4.27 m x 610 mm x 22 mm (14 ft. x 24 in. x 7/8 in.) with 152-mm x 16-mm (6 in. x 5/8 in.) cutting edge and 16-mm (5/8 in.) hardware	105 kg (231 lb.)
4.27 m x 610 mm x 22 mm (14 ft. x 24 in. x 7/8 in.) with 203-mm x 19-mm (8 in. x 3/4 in.) cutting edge and 16-mm (5/8 in.) hardware	157.4 kg (347 lb.)
4.27 m x 686 mm x 25 mm (14 ft. x 27 in. x 1 in.) with 203-mm x 19-mm (8 in. x 3/4 in.) cutting edge and 16-mm (5/8 in.) hardware	251.3 kg (554 lb.)
<b>Extensions, 610 mm (2 ft.) (right or left)</b>	
For Use with 610-mm (24 in.) Moldboards	115.7 kg (255 lb.)
For Use with 686-mm (27 in.) Moldboards	120.2 kg (265 lb.)
<b>Overlay End Bits, Reversible (one pair)</b>	
For 152-mm (6 in.) Cutting Edge	19.5 kg (43 lb.)
For 203-mm (8 in.) Cutting Edge	23.1 kg (51 lb.)
Heavy-Duty Dual-Input Circle-Drive Gearbox	14 kg (31 lb.)
Circle-Drive Slip Clutch	9.1 kg (20 lb.)
Moldboard Impact-Absorption System	43.1 kg (95 lb.)
Ripper/Scarifier, Rear Mounted with Hitch and Ripper Shanks (3)	1139 kg (2,510 lb.)
Scarifier Shanks with Teeth (9 for rear ripper/scarifier)	68 kg (150 lb.)
Ripper Shanks and Teeth (2)	63 kg (139 lb.)
Rear Counterweight with Integral Rear Hitch	727.1 kg (1,603 lb.)
Rear Hitch	54.4 kg (120 lb.)
Push Block, Front	1338 kg (2,950 lb.)
<b>Scarifier</b>	
Front Mount with Teeth (5)	831.4 kg (1,833 lb.)
<b>Machine Dimensions</b>	
A Height to Top of Cab	3.18 m (10 ft. 5 in.)
A' Height to Top of Full-Height Cab	3.40 m (11 ft. 2 in.)
B Height to Top of Exhaust (9.0L engine)	3.10 m (10 ft. 2 in.)
C Height to Top of Blade-Lift Cylinders	3.05 m (10 ft. 0 in.)
D Tandem Axle Spacing	1.54 m (5 ft. 1 in.)
E Blade Base	2.57 m (8 ft. 5 in.)

Option Weights (continued)	672G/GP
<b>Scarifier (continued)</b>	
Mid-Mount with Teeth (11)	1481 kg (3,265 lb.)
Front Lift Group (Balderson-style)	762.9 kg (1,682 lb.)
<b>Dozer Blade, Front Mounted</b>	
2464 mm x 955 mm (97 in. x 37.6 in.)	519 kg (1,146 lb.)
2667 mm x 955 mm (105 in. x 37.6 in.)	590 kg (1,301 lb.)
<b>Tires</b>	
14.00-24, 12 PR G2	- 220.4 kg (- 486 lb.)
17.5-25, 12 PR G2/L2	- 106.1 kg (- 234 lb.)
14.00-R24, Radial, G2/L2 General Purpose	0 kg (0 lb.)
14.00-R24, Radial, G2/L2 Snow	40.8 kg (90 lb.)
17.5-R25, Radial, L2 General Purpose	51.7 kg (114 lb.)
17.5-R25, Radial, G2/L2 Snow	95.3 kg (210 lb.)
17.5-R25, Radial, G3/L3 General Purpose	141.5 kg (312 lb.)
<b>One-Piece Rims</b>	
229 mm x 610 mm (9 in. x 24 in.)	0 kg (0 lb.)
330 mm x 635 mm (13 in. x 25 in.)	70.8 kg (156 lb.)
<b>Multi-Piece Rims</b>	
254 mm x 610 mm (10 in. x 24 in.)	119.7 kg (264 lb.)
356 mm x 635 mm (14 in. x 25 in.)	205 kg (452 lb.)
<b>Fenders</b>	
Front	76.7 kg (169 lb.)
Rear	140.6 kg (310 lb.)
Cab, Low with Opening Front and Side Windows	14.5 kg (32 lb.)
Premium Air-Suspension, Heated Seat with Adjustable Arm- and Headrests	12.7 kg (28 lb.)
Fast-Fill Fuel System	13.6 kg (30 lb.)
Quick Service	10.9 kg (24 lb.)
Sound-Absorption Package (machines equipped with Tier 3/Stage IIIA and Tier 2/Stage II engines only)	14.1 kg (31 lb.)
Secondary Steering	26.3 kg (58 lb.)
Beacon Bracket	8.2 kg (18 lb.)
Fire Extinguisher	14.5 kg (32 lb.)
<b>Lighting Packages</b>	
10 Halogen Lights	3.6 kg (8 lb.)
16 Halogen Lights	6.8 kg (15 lb.)
18 Halogen and/or LED Lights	8.2 kg (18 lb.)
High-Front Light Bar for Snowplowing	20 kg (44 lb.)
Auxiliary Hydraulic Control Valve Section and Controls	6.8 kg (15 lb.)
Hydraulics for Front-Mounted Equipment	8.6 kg (19 lb.)
<b>Machine Dimensions (continued)</b>	
F Wheelbase	6.16 m (20 ft. 3 in.)
G Overall Length	8.89 m (29 ft. 2 in.)
H Overall Length with Scarifier	9.69 m (31 ft. 9 in.)
I Overall Length with Push Block and Ripper	9.99 m (32 ft. 9 in.)
II Overall Length with Scarifier and Ripper	10.59 m (34 ft. 9 in.)
<i>For Overall Width see Tires/Wheels on page 22.</i>	

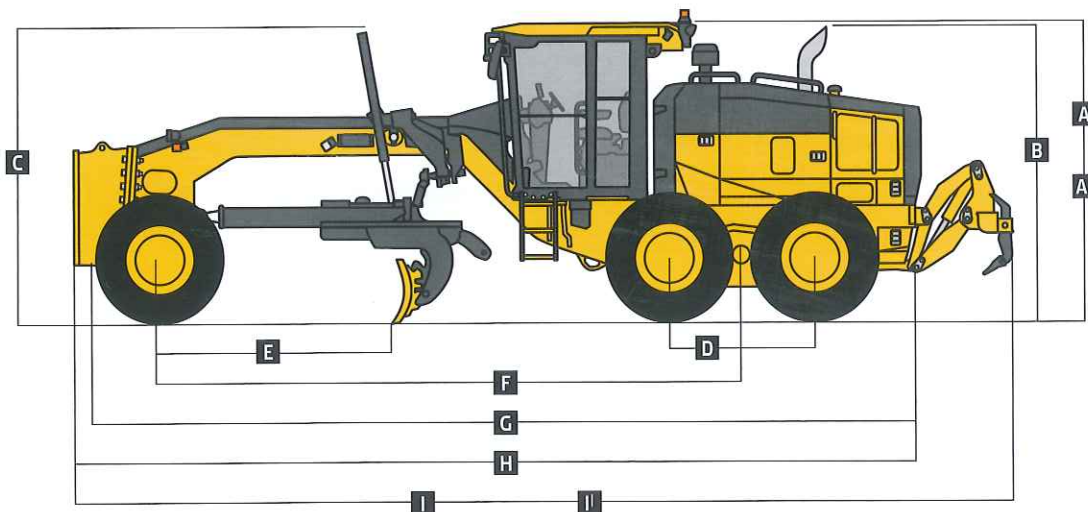

# 770G/GP

770G

Engine	770G/GP		
Manufacturer and Model	John Deere PowerTech™ PSS 9.0L	John Deere PowerTech™ Plus 9.0L	John Deere PowerTech™ 9.0L
Non-Road Emissions Standard	EPA Final Tier 4/EU Stage IV	EPA Tier 3/EU Stage IIIA	EPA Tier 2/EU Stage II
Cylinders	6	6	6
Displacement	9.0L (548 cu. in.)	9.0L (548 cu. in.)	9.0L (548 cu. in.)
Net Engine Power			
Gear 1	142 kW (190 hp)	123 kW (165 hp)	123 kW (165 hp)
Gear 2	153 kW (205 hp)	125 kW (167 hp)	125 kW (167 hp)
Gear 3	164 kW (220 hp)	137 kW (184 hp)	137 kW (184 hp)
Gear 4	172 kW (230 hp)	148 kW (198 hp)	148 kW (198 hp)
Gear 5	175 kW (235 hp)	160 kW (214 hp)	160 kW (214 hp)
Gear 6	183 kW (245 hp)	174 kW (233 hp)	174 kW (233 hp)
Gear 7	186 kW (250 hp)	181 kW (243 hp)	181 kW (243 hp)
Gear 8	190 kW (255 hp)	181 kW (243 hp)	181 kW (243 hp)
Net Peak Torque	1318 Nm (972 lb.-ft.)	1227 Nm (905 lb.-ft.)	1227 Nm (905 lb.-ft.)
Net Torque Rise	64%	63%	63%
Aspiration	Series turbocharged, charge-air cooled	Turbocharged, charge-air cooled	Turbocharged, charge-air cooled
Lubrication	Full-flow spin-on filter and integral cooler	Full-flow spin-on filter and integral cooler	Full-flow spin-on filter and integral cooler
Air Cleaner with Restriction Indicator	Dual element, dry	Dual element, dry	Dual element, dry
<b>Cooling</b>	Cooling-on-demand, hydraulic-driven, variable-speed fan drive to optimize fuel consumption; standard auto-reversing fan to keep coolers clean; swing-out rear fan door and pivoting or foldout coolers for easy cleaning of all cooling components		
Engine Coolant, Extended Life, Rating	-37 deg. C (-34 deg. F)		
<b>Powertrain</b>	Direct-drive John Deere PowerShift Plus™, modulated shift-on-the-go, Event-Based Shifting (EBS), inching pedal; independent transmission reservoir with separate filtration and cooling system with 117-L/min. (31 gpm) gear pump		
<b>Transmission</b>			
Gears			
Forward	8		
Reverse	8		
<b>Maximum Travel Speeds (forward and reverse)</b>	<i>With no tire slip at 2,180 rpm, 14R24 tires</i>		
Gear 1	4.0 km/h (2.5 mph)		
Gear 2	5.6 km/h (3.5 mph)		
Gear 3	7.7 km/h (4.8 mph)		
Gear 4	10.9 km/h (6.8 mph)		
Gear 5	16.4 km/h (10.2 mph)		
Gear 6	23.2 km/h (14.4 mph)		
Gear 7	32.3 km/h (20.1 mph)		
Gear 8	45.5 km/h (28.3 mph)		
<b>Front Axle</b>	Heavy-duty welded fabrication		
Oscillation (total)	32 deg.		
Wheel Lean Angle (each direction)	20 deg.		
<b>Differentials</b>	Spiral bevel; hydraulically actuated, clutch type can be applied on-the-go; selectable manual or automatic differential lock		
<b>Steering</b> (all models include steering wheel)	All-hydraulic power-frame articulation for maneuverability and productivity; crab steering reduces side drift, positions tandems on firm ground, and increases side-slope stability; return-to-straight control included in Grade Pro (GP) option		
Turning Radius (front steer and articulation)	7.21 m (23 ft. 8 in.)		
Articulation (both right and left)	22 deg.		
<b>Final Drives</b>	Inboard-mounted planetary sealed in cooled, filtered oil		
<b>Brakes</b>	Foot-controlled, hydraulically operated, multiple wet-disc brakes sealed in pressurized, cooled, filtered oil; both independent systems effective on all 4 tandem wheels		
Primary and Secondary Brakes	Hydraulically actuated, inboard of tandem pivot, self-adjusting, sealed in cooled and filtered oil, multi-disc (ISO 3450)		
Parking Brake	Automatically spring applied, hydraulically released, oil cooled, self-adjusting (ISO 3450)		



#### Hydraulics **770G/GP**

Closed-center, pressure-compensated load-sensing (PCLS), variable-displacement piston pump

Maximum Pump Flow 212 L/min. (56 gpm)

Maximum System Pressure 18 961 kPa (2,750 psi)

Pump Displacement 90 cm<sup>3</sup> (5.5 cu. in.)

#### Blade Function

All-hydraulic, industry-standard lever placement of blade-function controls; includes float position; 7 discrete saddle positions

#### Blade Range

Lift Above Ground 490 mm (19.3 in.)

Blade Side Shift (right or left) 683 mm (26.9 in.)

Pitch at Ground Line

Forward 42 deg.

Back 5 deg.

Shoulder Reach Outside Wheels (frame straight, right or left) 2083 mm (6 ft. 10 in.)

Bank Cut Angle (right or left) 90 deg.

#### Productivity

Blade Pull (maximum weight [21 772 kg (48,000 lb.)], 0.9 coefficient of traction) 13 150 kg (28,990 lb.)

#### Electrical

Solid-state load center and sealed-switch module

Voltage 24 volt

Number of Batteries 2

Battery Capacity 1,400 CCA

Reserve Capacity 440 min.

Amp-Hour Rating 224 amp-hour

Alternator Rating 100 / 130 / 200 amp

**Lights** Driving lights; 2 high- and 2 low-beam halogen headlights; front and rear LED turn signals and marker lights; LED brake and hazard warning lights

#### Mainframe

Type Welded box construction

Width (minimum) 307 mm (12.1 in.)

Height (minimum) 307 mm (12.1 in.)

Thickness

Side 16 mm (0.63 in.)

Top and Bottom Plate 23 mm (0.89 in.)

Modulus

Minimum Vertical Section 1770 cm<sup>3</sup> (108 cu. in.)

Average Vertical Section at Saddle 2245 cm<sup>3</sup> (137 cu. in.)

#### Draft Frame (drawbar)

Welded box construction machined for flatness with double ball-and-socket pivot connection equipped with quick-change replaceable wear inserts

#### Circle

Welded construction, heat-treated, machined for flatness, equipped with quick-change replaceable wear inserts

Circle Diameter 1524 mm (60 in.)

Rotation 360 deg.

Drive Hydraulic motor and worm gear with positive lock

Circle Side Shift (right and left) 787 mm (31 in.)

#### Moldboard

High-strength, pre-stressed for higher strength, wear-resistant, high-carbon steel and reversible end bits; blade side-shift wear system includes quick-change replaceable wear inserts and quick-adjust jackscrew system

Base Length 3.66 m (12 ft. 0 in.)

Height (measured along arc, including cutting edge) 610 mm (24 in.)

Thickness 22 mm (0.88 in.)

#### Cutting Edge

Dura-Max™ through-hardened steel edge

Thickness 16 mm (0.62 in.)

Width 152 mm (6 in.)

Scarifiers	770G/GP	
	<i>Front</i>	<i>Mid-mount</i>
Type	Parallel-linkage V-type toolbar with manual 2-pitch positions, with hydraulic float	Radial linkage, with NeverGrease™ pin joints; V-type toolbar with manual 3-pitch positions, with hydraulic float
Width of Cut	1.20 m (4 ft. 0 in.)	1.19 m (3 ft. 11 in.)
Number of Shanks/Teeth	5 (maximum capacity 9)	11
Lift Above Ground	589 mm (23.2 in.)	335 mm (13.2 in.)
Maximum Penetration	335 mm (13.2 in.)	325 mm (12.8 in.)
Shank		
Spacing	146 mm (5.75 in.)	117 mm (4.6 in.)
Size	25 x 76 mm (1 x 3 in.)	25 x 76 mm (1 x 3 in.)

#### Front Lift Group (Balderson-style)

Parallel linkage, mechanical pins, and hydraulic float

Lift	
Above Ground (top of tube)	1864 mm (73.4 in.)
Range	988 mm (38.9 in.)

#### Rear Ripper/Scarifier

Parallel linkage, with NeverGrease pin joints, hydraulic float, and integrated hitch

	<i>Ripper</i>	<i>Scarifier</i>
Width of Cut	2.21 m (7 ft. 3 in.)	2.18 m (7 ft. 2 in.)
Number of Shanks/Teeth	3 (maximum capacity 5)	None standard (maximum capacity 9)
Lift Above Ground	602 mm (23.7 in.)	810 mm (31.9 in.)
Maximum Penetration	426 mm (16.8 in.)	323 mm (12.7 in.)
Shank Size	61.5 x 133 mm (2.42 x 5.25 in.)	25 x 76 mm (1 x 3 in.)

#### Operator Station

Low-profile cab with ROPS (ISO 3471-2008) and FOPS (ISO 3449-2005)

#### Tires/Wheels

	14R24 on 254-mm (10 in.) Rim	17.5R25 on 356-mm (14 in.) Rim
Overall Width	2.49 m (98 in.)	2.64 m (104 in.)
Ground Clearance (front axle)	587 mm (23.1 in.)	587 mm (23.1 in.)

#### Serviceability

Refill Capacities	<i>EPA Final Tier 4/EU Stage IV</i>	<i>EPA Tier 3/EU Stage IIIA and EPA Tier 2/EU Stage II</i>
Fuel Tank	416.5 L (110 gal.)	416.5 L (110 gal.)
Diesel Exhaust Fluid (DEF) Tank	22.5 L (6 gal.)	—
Cooling System	55.0 L (14.5 gal.)	48.5 L (12.8 gal.)
Engine Oil with Filter	27.0 L (7.1 gal.)	27.0 L (7.1 gal.)
Transmission Fluid	28.4 L (7.5 gal.)	28.4 L (7.5 gal.)
Differential Housing	38.0 L (10 gal.)	38.0 L (10 gal.)
Tandem Housings (each)	74.0 L (19.5 gal.)	74.0 L (19.5 gal.)
Circle Gearbox	5.7 L (1.5 gal.)	5.7 L (1.5 gal.)
Hydraulic Reservoir	60.5 L (16 gal.)	53.0 L (14 gal.)

#### Operating Weights

With Full Fuel Tank, 3.66-m x 610-mm x 22-mm (12 ft. x 24 in. x 0.88 in.) Moldboards with 152-mm x 16-mm (6 in. x 5/8 in.) Cutting Edges, 14R24 L2 Tires, and 79-kg (175 lb.)

Operator	<i>EPA Final Tier 4/EU Stage IV</i>	<i>EPA Tier 3/EU Stage IIIA and EPA Tier 2/EU Stage II</i>
Front	4305 kg (9,490 lb.)	4314 kg (9,510 lb.)
Rear	12 084 kg (26,640 lb.)	11 440 kg (25,220 lb.)
Total	16 388 kg (36,130 lb.)	15 753 kg (34,730 lb.)

Typical Operating Weight with Front Push Block, Rear Ripper/Scarifier, and Other

Equipment		
Front	5570 kg (12,280 lb.)	5605 kg (12,358 lb.)
Rear	13 825 kg (30,480 lb.)	13 175 kg (29,047 lb.)
Total	19 396 kg (42,760 lb.)	18 781 kg (41,405 lb.)
Maximum Operating Weight	21 772 kg (48,000 lb.)	21 772 kg (48,000 lb.)

Option Weights	770G/GP
Moldboards with Through-Hardened Dura-Max Cutting Edge	
3.66 m x 610 mm x 22 mm (12 ft. x 24 in. x 7/8 in.) with 152-mm x 16-mm (6 in. x 5/8 in.) cutting edge and 16-mm (5/8 in.) hardware	0 kg (0 lb.)
3.66 m x 610 mm x 22 mm (12 ft. x 24 in. x 7/8 in.) with 203-mm x 19-mm (8 in. x 3/4 in.) cutting edge and 16-mm (5/8 in.) hardware	45 kg (99 lb.)
3.66 m x 686 mm x 25 mm (12 ft. x 27 in. x 1 in.) with 203-mm x 19-mm (8 in. x 3/4 in.) cutting edge and 16-mm (5/8 in.) hardware	126 kg (277 lb.)
3.96 m x 686 mm x 25 mm (13 ft. x 27 in. x 1 in.) with 203-mm x 19-mm (8 in. x 3/4 in.) cutting edge and 16-mm (5/8 in.) hardware	180 kg (396 lb.)
4.27 m x 610 mm x 22 mm (14 ft. x 24 in. x 7/8 in.) with 152-mm x 16-mm (6 in. x 5/8 in.) cutting edge and 16-mm (5/8 in.) hardware	105 kg (231 lb.)
4.27 m x 610 mm x 22 mm (14 ft. x 24 in. x 7/8 in.) with 203-mm x 19-mm (8 in. x 3/4 in.) cutting edge and 16-mm (5/8 in.) hardware	157.4 kg (347 lb.)
4.27 m x 686 mm x 25 mm (14 ft. x 27 in. x 1 in.) with 203-mm x 19-mm (8 in. x 3/4 in.) cutting edge and 16-mm (5/8 in.) hardware	251.3 kg (554 lb.)
4.27 m x 686 mm x 25 mm (14 ft. x 27 in. x 1 in.) with 203-mm x 19-mm (8 in. x 3/4 in.) cutting edge and 19-mm (3/4 in.) hardware	260.8 kg (575 lb.)
Extensions, 610 mm (2 ft.) (right or left)	
For Use with 610-mm (24 in.) Moldboards	98.9 kg (218 lb.)
For Use with 686-mm (27 in.) Moldboards	103.4 kg (228 lb.)
Overlay End Bits, Reversible (one pair)	
For 152-mm (6 in.) Cutting Edge	19.5 kg (43 lb.)
For 203-mm (8 in.) Cutting Edge	23.1 kg (51 lb.)
Heavy-Duty Dual-Input Circle-Drive Gearbox	14 kg (31 lb.)
Circle-Drive Slip Clutch	9.1 kg (20 lb.)
Moldboard Impact-Absorption System	43.1 kg (95 lb.)
Ripper/Scarifier, Rear Mounted with Hitch and Ripper Shanks (3)	1139 kg (2,510 lb.)
Scarifier Shanks with Teeth (9 for rear ripper/scarifier)	68 kg (150 lb.)
Ripper Shanks and Teeth (2)	63 kg (139 lb.)
Rear Counterweight with Integral Rear Hitch	727.1 kg (1,603 lb.)
Rear Hitch	54.4 kg (120 lb.)
Push Block, Front	1338 kg (2,950 lb.)
Scarifier	
Front Mount with Teeth (5)	831.4 kg (1,833 lb.)

Machine Dimensions	
A Height to Top of Cab	3.18 m (10 ft. 5 in.)
A' Height to Top of Full-Height Cab	3.40 m (11 ft. 2 in.)
B Height to Top of Exhaust	3.10 m (10 ft. 2 in.)
C Height to Top of Blade-Lift Cylinders	3.05 m (10 ft. 0 in.)
D Tandem Axle Spacing	1.54 m (5 ft. 1 in.)
E Blade Base	2.57 m (8 ft. 5 in.)

Option Weights (continued)	770G/GP
Scarifier (continued)	
Mid-Mount with Teeth (11)	1481 kg (3,265 lb.)
Front Lift Group (Balderson-style)	762.9 kg (1,682 lb.)
Dozer Blade, Front Mounted	
2464 mm x 955 mm (97 in. x 37.6 in.)	519 kg (1,146 lb.)
2667 mm x 955 mm (105 in. x 37.6 in.)	590 kg (1,301 lb.)
2921 mm x 955 mm (115 in. x 37.6 in.)	648 kg (1,429 lb.)
Tires	
14.00-24, 12 PR G2	- 220.4 kg (- 486 lb.)
17.5-25, 12 PR G2/L2	- 106.1 kg (- 234 lb.)
14.00-R24, Radial, G2/L2 General Purpose	0 kg (0 lb.)
14.00-R24, Radial, G2/L2 Snow	40.8 kg (90 lb.)
17.5-R25, Radial, L2 General Purpose	51.7 kg (114 lb.)
17.5-R25, Radial, G2/L2 Snow	95.3 kg (210 lb.)
17.5-R25, Radial, G3/L3 General Purpose	141.5 kg (312 lb.)
550/65R25 XLD70 G3/L3 Radial, General Purpose	495.3 kg (1,092 lb.)
One-Piece Rims	
229 mm x 610 mm (9 in. x 24 in.)	0 kg (0 lb.)
330 mm x 635 mm (13 in. x 25 in.)	65.3 kg (144 lb.)
Multi-Piece Rims	
254 mm x 610 mm (10 in. x 24 in.)	179.6 kg (396 lb.)
356 mm x 635 mm (14 in. x 25 in.)	266.7 kg (588 lb.)
Fenders	
Front	76.7 kg (169 lb.)
Rear	140.6 kg (310 lb.)
Cab, Low with Opening Front and Side Windows	14.5 kg (32 lb.)
Premium Air-Suspension, Heated Seat with Adjustable Arm- and Headrests	12.7 kg (28 lb.)
Fast-Fill Fuel System	13.6 kg (30 lb.)
Quick Service	10.9 kg (24 lb.)
Sound-Absorption Package (machines equipped with Tier 3/Stage IIIA and Tier 2/Stage II engines only)	14.1 kg (31 lb.)
Secondary Steering	26.3 kg (58 lb.)
Beacon Bracket	8.2 kg (18 lb.)
Fire Extinguisher	14.5 kg (32 lb.)
Lighting Packages	
10 Halogen Lights	4.5 kg (10 lb.)
16 Halogen Lights	7.3 kg (16 lb.)
18 Halogen and/or LED Lights	8.2 kg (18 lb.)
High-Front Light Bar for Snowplowing	20 kg (44 lb.)
Auxiliary Hydraulic Control Valve Section and Controls	6.8 kg (15 lb.)
Hydraulics for Front-Mounted Equipment	8.6 kg (19 lb.)

Machine Dimensions (continued)	
F Wheelbase	6.16 m (20 ft. 3 in.)
G Overall Length	8.89 m (29 ft. 2 in.)
H Overall Length with Scarifier	9.69 m (31 ft. 9 in.)
I Overall Length with Push Block and Ripper	9.99 m (32 ft. 9 in.)
I' Overall Length with Scarifier and Ripper	10.59 m (34 ft. 9 in.)

For Overall Width see Tires/Wheels on page 26.

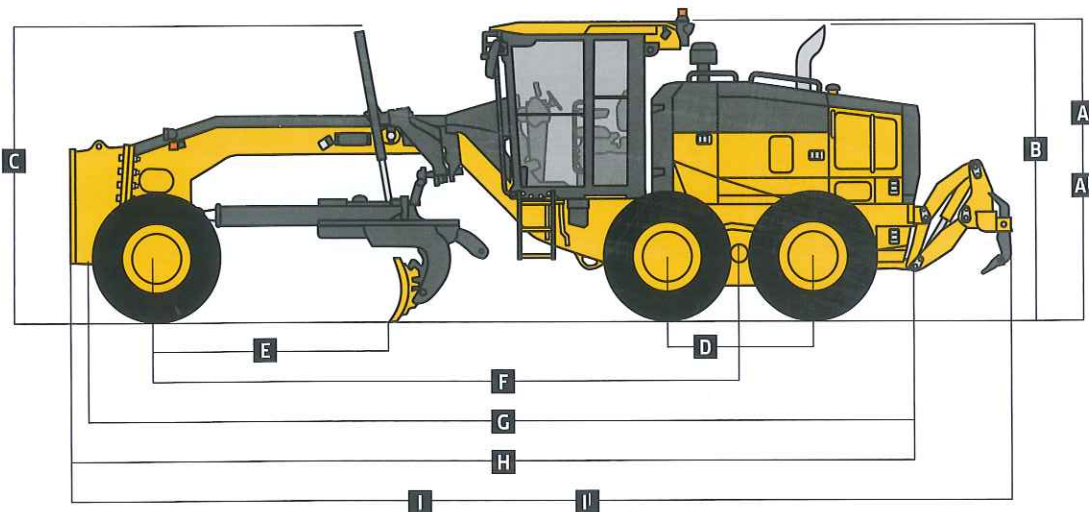

# 772G/GP



Engine	772G/GP		
Manufacturer and Model	John Deere PowerTech™ PSS 9.0L	John Deere PowerTech™ Plus 9.0L	John Deere PowerTech™ 9.0L
Non-Road Emissions Standard	EPA Final Tier 4/EU Stage IV	EPA Tier 3/EU Stage IIIA	EPA Tier 2/EU Stage II
Cylinders	6	6	6
Displacement	9.0L (548 cu. in.)	9.0L (548 cu. in.)	9.0L (548 cu. in.)
Net Engine Power			
Gear 1 (6WD on)	157 kW (210 hp)	145 kW (194 hp)	145 kW (194 hp)
Gear 2 (6WD on)	168 kW (225 hp)	148 kW (198 hp)	148 kW (198 hp)
Gear 3 (6WD on)	179 kW (240 hp)	164 kW (220 hp)	164 kW (220 hp)
Gear 4 (6WD on)	186 kW (250 hp)	164 kW (220 hp)	164 kW (220 hp)
Gear 5 (6WD on)	190 kW (255 hp)	174 kW (234 hp)	174 kW (234 hp)
Gear 6 (6WD on)	198 kW (265 hp)	194 kW (260 hp)	194 kW (260 hp)
Gear 7 (6WD on)	205 kW (275 hp)	194 kW (260 hp)	194 kW (260 hp)
Gear 8	198 kW (265 hp)	188 kW (252 hp)	188 kW (252 hp)
Net Peak Torque	1375 Nm (1014 lb.-ft.)	1288 Nm (950 lb.-ft.)	1288 Nm (950 lb.-ft.)
Net Torque Rise	55%	55%	55%
Aspiration	Series turbocharged, charge-air cooled	Turbocharged, charge-air cooled	Turbocharged, charge-air cooled
Lubrication	Full-flow spin-on filter and integral cooler	Full-flow spin-on filter and integral cooler	Full-flow spin-on filter and integral cooler
Air Cleaner with Restriction Indicator	Dual element, dry	Dual element, dry	Dual element, dry

## Cooling

Cooling-on-demand, hydraulic-driven, variable-speed fan drive to optimize fuel consumption; standard auto-reversing fan to keep coolers clean; swing-out rear fan door and pivoting or foldout coolers for easy cleaning of all cooling components

Engine Coolant, Extended Life, Rating -37 deg. C (-34 deg. F)

## Powertrain

### 6-Wheel Drive

Automatic dual-path hydrostatic drive; increases tractive effort and front-end control; includes separate left and right systems with variable-displacement pumps, axial-piston wheel motors, and freewheel at transport speeds; operator-selectable 15-position rotary aggressiveness control and inching capability down to 0 mph; precision mode (propelled by front wheels only)

6-Wheel-Drive Effective Gears 1-7 forward and reverse

#### Precision Mode

Effective Gears 1-3 forward only  
Operating Speeds 0.4-8.0 km/h (0.25-5.0 mph)

Hydrostatic Pumps (2 each) 64 cm<sup>3</sup> (3.9 cu. in.)

Wheel Motors 60 cm<sup>3</sup> (3.7 cu. in.)

Final Reduction 38.7:1

### Transmission

Direct-drive John Deere PowerShift Plus™, modulated shift-on-the-go, Event-Based Shifting (EBS), inching pedal; independent transmission reservoir with separate filtration and cooling system with 117-L/min. (31 gpm) gear pump

#### Gears

Forward 8

Reverse 8

### Maximum Travel Speeds (forward and reverse)

*With no tire slip at 2,180 rpm, 14R24 tires*

Gear 1 4.0 km/h (2.5 mph)

Gear 2 5.6 km/h (3.5 mph)

Gear 3 7.7 km/h (4.8 mph)

Gear 4 10.9 km/h (6.8 mph)

Gear 5 16.4 km/h (10.2 mph)

Gear 6 23.2 km/h (14.4 mph)

Gear 7 32.3 km/h (20.1 mph)

Gear 8 45.5 km/h (28.3 mph)

### Front Axle

Heavy-duty welded fabrication

Oscillation (total) 32 deg.

Wheel Lean Angle (each direction) 20 deg.

### Differentials

Spiral bevel; hydraulically actuated, clutch type can be applied on-the-go; selectable manual or automatic differential lock

### Steering (all models include steering wheel)

All-hydraulic power-frame articulation for maneuverability and productivity; crab steering reduces side drift, positions tandems on firm ground, and increases side-slope stability; return-to-straight control included in Grade Pro (GP) option

Turning Radius (front steer and articulation) 7.21 m (23 ft. 8 in.)

Articulation (both right and left) 22 deg.

### Final Drives

Inboard-mounted planetary sealed in cooled, filtered oil



#### Powertrain (continued)

772G/GP

**Brakes** Foot-controlled, hydraulically operated, multiple wet-disc brakes sealed in pressurized, cooled, filtered oil; both independent systems effective on all 4 tandem wheels

Primary and Secondary Brakes Hydraulically actuated, inboard of tandem pivot, self-adjusting, sealed in cooled and filtered oil, multi-disc (ISO 3450)

Parking Brake Automatically spring applied, hydraulically released, oil cooled, self-adjusting (ISO 3450)

#### Hydraulics

Closed-center, pressure-compensated load-sensing (PCLS), variable-displacement piston pump

Maximum Pump Flow 212 L/min. (56 gpm)

Maximum System Pressure 18 961 kPa (2,750 psi)

Pump Displacement 90 cm<sup>3</sup> (5.5 cu. in.)

#### Blade Function

All-hydraulic, industry-standard lever placement of blade-function controls; includes float position; 7 discrete saddle positions

#### Blade Range

Lift Above Ground 490 mm (19.3 in.)

Blade Side Shift (right or left) 683 mm (26.9 in.)

Pitch at Ground Line

Forward 42 deg.

Back 5 deg.

Shoulder Reach Outside Wheels (frame straight, right or left) 2083 mm (6 ft. 10 in.)

Bank Cut Angle (right or left) 90 deg.

#### Productivity

Blade Pull (maximum weight [21 772 kg (48,000 lb.)], 0.9 coefficient of traction) 17 913 kg (39,491 lb.)

#### Electrical

Solid-state load center and sealed-switch module

Voltage 24 volt

Number of Batteries 2

Battery Capacity 1,400 CCA

Reserve Capacity 440 min.

Amp-Hour Rating 224 amp-hour

Alternator Rating 100 / 130 / 200 amp

**Lights** Driving lights; 2 high- and 2 low-beam halogen headlights; front and rear LED turn signals and marker lights; LED brake and hazard warning lights

#### Mainframe

Type Welded box construction

Width (minimum) 307 mm (12.1 in.)

Height (minimum) 307 mm (12.1 in.)

Thickness

Side 16 mm (0.63 in.)

Top and Bottom Plate 23 mm (0.89 in.)

Modulus

Minimum Vertical Section 1770 cm<sup>3</sup> (108 cu. in.)

Average Vertical Section at Saddle 2245 cm<sup>3</sup> (137 cu. in.)

#### Draft Frame (drawbar)

Welded box construction machined for flatness with double ball-and-socket pivot connection equipped with quick-change replaceable wear inserts

#### Circle

Welded construction, heat-treated, machined for flatness, equipped with quick-change replaceable wear inserts

Circle Diameter 1524 mm (60 in.)

Rotation 360 deg.

Drive Hydraulic motor and worm gear with positive lock

Circle Side Shift (right and left) 787 mm (31 in.)

#### Moldboard

High-strength, pre-stressed for higher strength, wear-resistant, high-carbon steel and reversible end bits; blade side-shift wear system includes quick-change replaceable wear inserts and quick-adjust jackscrew system

Base Length 3.66 m (12 ft. 0 in.)

Height (measured along arc, including cutting edge) 610 mm (24 in.)

Thickness 22 mm (0.88 in.)

<b>Cutting Edge</b> 772G/GP		
Dura-Max™ through-hardened steel edge		
Thickness	16 mm (0.62 in.)	
Width	152 mm (6 in.)	
<b>Scarifiers</b>		
	<i>Front</i>	<i>Mid-mount</i>
Type	Parallel-linkage V-type toolbar with manual 2-pitch positions, with hydraulic float	Radial linkage, with NeverGrease™ pin joints; V-type toolbar with manual 3-pitch positions, with hydraulic float
Width of Cut	1.20 m (4 ft. 0 in.)	1.19 m (3 ft. 11 in.)
Number of Shanks/Teeth	5 (maximum capacity 9)	11
Lift Above Ground	589 mm (23.2 in.)	335 mm (13.2 in.)
Maximum Penetration	335 mm (13.2 in.)	325 mm (12.8 in.)
Shank		
Spacing	146 mm (5.75 in.)	117 mm (4.6 in.)
Size	25 x 76 mm (1 x 3 in.)	25 x 76 mm (1 x 3 in.)
<b>Front Lift Group (Balderson-style)</b>		
Parallel linkage, mechanical pins, and hydraulic float		
Lift		
Above Ground (top of tube)	1864 mm (73.4 in.)	
Range	988 mm (38.9 in.)	
<b>Rear Ripper/Scarifier</b>		
Parallel linkage, with NeverGrease pin joints, hydraulic float, and integrated hitch		
	<i>Ripper</i>	<i>Scarifier</i>
Width of Cut	2.21 m (7 ft. 3 in.)	2.18 m (7 ft. 2 in.)
Number of Shanks/Teeth	3 (maximum capacity 5)	None standard (maximum capacity 9)
Lift Above Ground	602 mm (23.7 in.)	810 mm (31.9 in.)
Maximum Penetration	426 mm (16.8 in.)	323 mm (12.7 in.)
Shank Size	61.5 x 133 mm (2.42 x 5.25 in.)	25 x 76 mm (1 x 3 in.)
<b>Operator Station</b>		
Low-profile cab with ROPS (ISO 3471-2008) and FOPS (ISO 3449-2005)		
<b>Tires/Wheels</b>		
	14R24 on 254-mm (10 in.) Rim	17.5R25 on 356-mm (14 in.) Rim
Overall Width	2.49 m (98 in.)	2.64 m (104 in.)
Ground Clearance (front axle)	587 mm (23.1 in.)	587 mm (23.1 in.)
<b>Serviceability</b>		
<b>Refill Capacities</b>	<i>EPA Final Tier 4/EU Stage IV</i>	<i>EPA Tier 3/EU Stage IIIA and EPA Tier 2/EU Stage II</i>
Fuel Tank	416.5 L (110 gal.)	416.5 L (110 gal.)
Diesel Exhaust Fluid (DEF) Tank	22.5 L (6 gal.)	—
Cooling System	55.0 L (14.5 gal.)	48.5 L (12.8 gal.)
Engine Oil with Filter	27.0 L (7.1 gal.)	27.0 L (7.1 gal.)
Transmission Fluid	28.4 L (7.5 gal.)	28.4 L (7.5 gal.)
Differential Housing	38.0 L (10 gal.)	38.0 L (10 gal.)
Tandem Housings (each)	74.0 L (19.5 gal.)	74.0 L (19.5 gal.)
Circle Gearbox	5.7 L (1.5 gal.)	5.7 L (1.5 gal.)
Hydraulic Reservoir	60.5 L (16 gal.)	53.0 L (14 gal.)
<b>Operating Weights</b>		
With Full Fuel Tank, 3.66-m x 610-mm x 22-mm (12 ft. x 24 in. x 0.88 in.) Moldboards with 152-mm x 16-mm (6 in. x 5/8 in.) Cutting Edges, 14R24 L2 Tires, and 79-kg (175 lb.) Operator		
	<i>EPA Final Tier 4/EU Stage IV</i>	<i>EPA Tier 3/EU Stage IIIA and EPA Tier 2/EU Stage II</i>
Front	4881 kg (10,760 lb.)	4890 kg (10,780 lb.)
Rear	12 501 kg (27,560 lb.)	11 857 kg (26,140 lb.)
Total	17 382 kg (38,320 lb.)	16 747 kg (36,920 lb.)
Typical Operating Weight with Front Push Block, Rear Ripper/Scarifier, and Other Equipment		
Front	6142 kg (13,540 lb.)	6177 kg (13,618 lb.)
Rear	14 075 kg (31,030 lb.)	13 427 kg (29,602 lb.)
Total	20 217 kg (44,570 lb.)	19 604 kg (43,220 lb.)
Maximum Operating Weight	21 772 kg (48,000 lb.)	21 772 kg (48,000 lb.)

Option Weights	772G/GP
Moldboards with Through-Hardened Dura-Max Cutting Edge	
3.66 m x 610 mm x 22 mm (12 ft. x 24 in. x 7/8 in.) with 152-mm x 16-mm (6 in. x 5/8 in.) cutting edge and 16-mm (5/8 in.) hardware	0 kg (0 lb.)
3.66 m x 610 mm x 22 mm (12 ft. x 24 in. x 7/8 in.) with 203-mm x 19-mm (8 in. x 3/4 in.) cutting edge and 16-mm (5/8 in.) hardware	45 kg (99 lb.)
3.66 m x 686 mm x 25 mm (12 ft. x 27 in. x 1 in.) with 203-mm x 19-mm (8 in. x 3/4 in.) cutting edge and 16-mm (5/8 in.) hardware	126 kg (277 lb.)
3.96 m x 686 mm x 25 mm (13 ft. x 27 in. x 1 in.) with 203-mm x 19-mm (8 in. x 3/4 in.) cutting edge and 16-mm (5/8 in.) hardware	180 kg (396 lb.)
4.27 m x 610 mm x 22 mm (14 ft. x 24 in. x 7/8 in.) with 152-mm x 16-mm (6 in. x 5/8 in.) cutting edge and 16-mm (5/8 in.) hardware	105 kg (231 lb.)
4.27 m x 610 mm x 22 mm (14 ft. x 24 in. x 7/8 in.) with 203-mm x 19-mm (8 in. x 3/4 in.) cutting edge and 16-mm (5/8 in.) hardware	157.4 kg (347 lb.)
4.27 m x 686 mm x 25 mm (14 ft. x 27 in. x 1 in.) with 203-mm x 19-mm (8 in. x 3/4 in.) cutting edge and 16-mm (5/8 in.) hardware	251.3 kg (554 lb.)
4.27 m x 686 mm x 25 mm (14 ft. x 27 in. x 1 in.) with 203-mm x 19-mm (8 in. x 3/4 in.) cutting edge and 19-mm (3/4 in.) hardware	260.8 kg (575 lb.)
Extensions, 610 mm (2 ft.) (right or left)	
For Use with 610-mm (24 in.) Moldboards	115.7 kg (255 lb.)
For Use with 686-mm (27 in.) Moldboards	120.2 kg (265 lb.)
Overlay End Bits, Reversible (one pair)	
For 152-mm (6 in.) Cutting Edge	19.5 kg (43 lb.)
For 203-mm (8 in.) Cutting Edge	23.1 kg (51 lb.)
Heavy-Duty Dual-Input Circle-Drive Gearbox	14 kg (31 lb.)
Circle-Drive Slip Clutch	9.1 kg (20 lb.)
Moldboard Impact-Absorption System	43.1 kg (95 lb.)
Ripper/Scarifier, Rear Mounted with Hitch and Ripper Shanks (3)	1139 kg (2,510 lb.)
Scarifier Shanks with Teeth (9 for rear ripper/scarifier)	68 kg (150 lb.)
Ripper Shanks and Teeth (2)	63 kg (139 lb.)
Rear Counterweight with Integral Rear Hitch	727.1 kg (1,603 lb.)
Rear Hitch	54.4 kg (120 lb.)
Push Block, Front	1338 kg (2,950 lb.)
Scarifier	
Front Mount with Teeth (5)	831.4 kg (1,833 lb.)
<b>Machine Dimensions</b>	
A Height to Top of Cab	3.18 m (10 ft. 5 in.)
A <sup>1</sup> Height to Top of Full-Height Cab	3.40 m (11 ft. 2 in.)
B Height to Top of Exhaust	3.10 m (10 ft. 2 in.)
C Height to Top of Blade-Lift Cylinders	3.05 m (10 ft. 0 in.)
D Tandem Axle Spacing	1.54 m (5 ft. 1 in.)
E Blade Base	2.57 m (8 ft. 5 in.)

Option Weights (continued)	772G/GP
Scarifier (continued)	
Mid-Mount with Teeth (11)	1481 kg (3,265 lb.)
Front Lift Group (Balderson-style)	762.9 kg (1,682 lb.)
Dozer Blade, Front Mounted	
2464 mm x 955 mm (97 in. x 37.6 in.)	519 kg (1,146 lb.)
2667 mm x 955 mm (105 in. x 37.6 in.)	590 kg (1,301 lb.)
2921 mm x 955 mm (115 in. x 37.6 in.)	648 kg (1,429 lb.)
Tires	
14.00-24, 12 PR G2	- 220.4 kg (- 486 lb.)
17.5-25, 12 PR G2/L2	- 106.1 kg (- 234 lb.)
14.00-R24, Radial, G2/L2 General Purpose	0 kg (0 lb.)
14.00-R24, Radial, G2/L2 Snow	40.8 kg (90 lb.)
17.5-R25, Radial, L2 General Purpose	51.7 kg (114 lb.)
17.5-R25, Radial, G2/L2 Snow	95.3 kg (210 lb.)
17.5-R25, Radial, G3/L3 General Purpose	141.5 kg (312 lb.)
550/65R25 XLD70 G3/L3 Radial, General Purpose	495.3 kg (1,092 lb.)
One-Piece Rims	
229 mm x 610 mm (9 in. x 24 in.)	0 kg (0 lb.)
330 mm x 635 mm (13 in. x 25 in.)	70.8 kg (156 lb.)
Multi-Piece Rims	
254 mm x 610 mm (10 in. x 24 in.)	119.7 kg (264 lb.)
356 mm x 635 mm (14 in. x 25 in.)	205 kg (452 lb.)
Fenders	
Front	76.7 kg (169 lb.)
Rear	140.6 kg (310 lb.)
Cab, Low with Opening Front and Side Windows	14.5 kg (32 lb.)
Premium Air-Suspension, Heated Seat with Adjustable Arm- and Headrests	12.7 kg (28 lb.)
Fast-Fill Fuel System	13.6 kg (30 lb.)
Quick Service	10.9 kg (24 lb.)
Sound-Absorption Package (machines equipped with Tier 3/Stage IIIA and Tier 2/Stage II engines only)	14.1 kg (31 lb.)
Secondary Steering	26.3 kg (58 lb.)
Beacon Bracket	8.2 kg (18 lb.)
Fire Extinguisher	14.5 kg (32 lb.)
Lighting Packages	
10 Halogen Lights	4.5 kg (10 lb.)
16 Halogen Lights	7.3 kg (16 lb.)
18 Halogen and/or LED Lights	8.2 kg (18 lb.)
High-Front Light Bar for Snowplowing	20 kg (44 lb.)
Auxiliary Hydraulic Control Valve Section and Controls	6.8 kg (15 lb.)
Hydraulics for Front-Mounted Equipment	8.6 kg (19 lb.)
<b>Machine Dimensions (continued)</b>	
F Wheelbase	6.16 m (20 ft. 3 in.)
G Overall Length	8.89 m (29 ft. 2 in.)
H Overall Length with Scarifier	9.69 m (31 ft. 9 in.)
I Overall Length with Push Block and Ripper	9.99 m (32 ft. 9 in.)
II Overall Length with Scarifier and Ripper	10.59 m (34 ft. 9 in.)
<i>For Overall Width see Tires/Wheels on page 30.</i>	

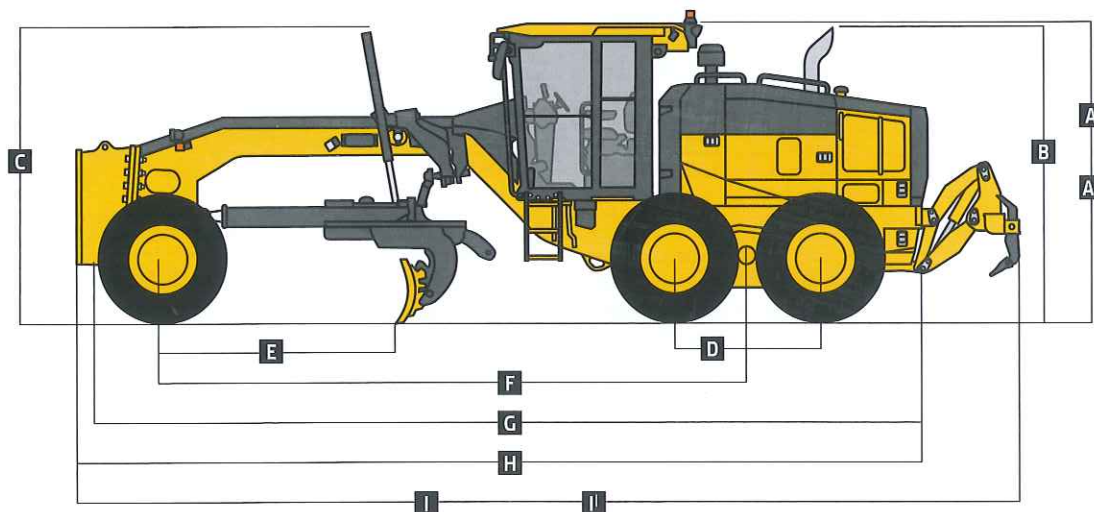

# 870G/GP

Engine	870G/GP		
Manufacturer and Model	John Deere PowerTech™ PSS 9.0L	John Deere PowerTech™ Plus 9.0L	John Deere PowerTech™ 9.0L
Non-Road Emissions Standard	EPA Final Tier 4/EU Stage IV	EPA Tier 3/EU Stage IIIA	EPA Tier 2/EU Stage II
Cylinders	6	6	6
Displacement	9.0L (548 cu. in.)	9.0L (548 cu. in.)	9.0L (548 cu. in.)
Net Engine Power			
Gear 1	160 kW (215 hp)	134 kW (180 hp)	134 kW (180 hp)
Gear 2	172 kW (230 hp)	135 kW (182 hp)	135 kW (182 hp)
Gear 3	183 kW (245 hp)	152 kW (204 hp)	152 kW (204 hp)
Gear 4	190 kW (255 hp)	163 kW (219 hp)	163 kW (219 hp)
Gear 5	194 kW (260 hp)	169 kW (227 hp)	169 kW (227 hp)
Gear 6	201 kW (270 hp)	184 kW (247 hp)	184 kW (247 hp)
Gear 7	205 kW (275 hp)	191 kW (257 hp)	191 kW (257 hp)
Gear 8	209 kW (280 hp)	191 kW (257 hp)	191 kW (257 hp)
Net Peak Torque	1428 Nm (1053 lb.-ft.)	1287 Nm (949 lb.-ft.)	1287 Nm (949 lb.-ft.)
Net Torque Rise	62%	60%	60%
Aspiration	Series turbocharged, charge-air cooled	Turbocharged, charge-air cooled	Turbocharged, charge-air cooled
Lubrication	Full-flow spin-on filter and integral cooler	Full-flow spin-on filter and integral cooler	Full-flow spin-on filter and integral cooler
Air Cleaner with Restriction Indicator	Dual element, dry	Dual element, dry	Dual element, dry

## Cooling

Cooling-on-demand, hydraulic-driven, variable-speed fan drive to optimize fuel consumption; standard auto-reversing fan to keep coolers clean; swing-out rear fan door and pivoting or foldout coolers for easy cleaning of all cooling components

Engine Coolant, Extended Life, Rating -37 deg. C (-34 deg. F)

## Powertrain

**Transmission** Direct-drive John Deere PowerShift Plus™, modulated shift-on-the-go, Event-Based Shifting (EBS), inching pedal; independent transmission reservoir with separate filtration and cooling system with 121-L/min. (32 gpm) gear pump

### Gears

Forward	8
Reverse	8

**Maximum Travel Speeds (forward and reverse)** *With no tire slip at 2,180 rpm, 14R24 tires*

Gear 1	3.9 km/h (2.4 mph)
Gear 2	5.6 km/h (3.5 mph)
Gear 3	7.9 km/h (4.9 mph)
Gear 4	10.9 km/h (6.8 mph)
Gear 5	16.7 km/h (10.4 mph)
Gear 6	23.3 km/h (14.5 mph)
Gear 7	32.2 km/h (20.0 mph)
Gear 8	45.0 km/h (28.0 mph)

### Front Axle

Oscillation (total)	32 deg.
Wheel Lean Angle (each direction)	20 deg.

### Differentials

**Steering** (all models include steering wheel) All-hydraulic power-frame articulation for maneuverability and productivity; crab steering reduces side drift, positions tandems on firm ground, and increases side-slope stability; return-to-straight control included in Grade Pro (GP) option

Turning Radius (front steer and articulation)	7.21 m (23 ft. 8 in.)
Articulation (both right and left)	22 deg.

### Final Drives

**Brakes** Inboard-mounted planetary sealed in cooled, filtered oil  
Foot-controlled, hydraulically operated, multiple wet-disc brakes sealed in pressurized, cooled, filtered oil; both independent systems effective on all 4 tandem wheels

Primary and Secondary Brakes	Hydraulically actuated, inboard of tandem pivot, self-adjusting, sealed in cooled and filtered oil, multi-disc (ISO 3450)
Parking Brake	Automatically spring applied, hydraulically released, oil cooled, self-adjusting (ISO 3450)



### Hydraulics 870G/GP

Closed-center, pressure-compensated load-sensing (PCLS), variable-displacement piston pump	
Maximum Pump Flow	218 L/min. (57.5 gpm)
Maximum System Pressure	18 961 kPa (2,750 psi)
Pump Displacement	90 cm <sup>3</sup> (5.5 cu. in.)

### Blade Function

All-hydraulic, industry-standard lever placement of blade-function controls; includes float position; 7 discrete saddle positions

### Blade Range

Lift Above Ground	452 mm (17.8 in.)
Blade Side Shift (right or left)	683 mm (26.9 in.)
Pitch at Ground Line	
Forward	42 deg.
Back	5 deg.
Shoulder Reach Outside Wheels (frame straight, right or left)	2329 mm (7 ft. 8 in.)
Bank Cut Angle (right or left)	90 deg.

### Productivity

Blade Pull (maximum weight [22 054 kg (48,620 lb.)], 0.9 coefficient of traction)	13 299 kg (29,320 lb.)
---	------------------------

### Electrical

Solid-state load center and sealed-switch module

Voltage	24 volt
Number of Batteries	2
Battery Capacity	1,400 CCA
Reserve Capacity	440 min.
Amp-Hour Rating	224 amp-hour
Alternator Rating	100 / 130 / 200 amp

**Lights** Driving lights; 2 high- and 2 low-beam halogen headlights; front and rear LED turn signals and marker lights; LED brake and hazard warning lights

### Mainframe

Type	Welded box construction
Width (minimum)	307 mm (12.1 in.)
Height (minimum)	307 mm (12.1 in.)
Thickness	
Side	16 mm (0.63 in.)
Top and Bottom Plate	30 mm (1.17 in.)
Modulus	
Minimum Vertical Section	1770 cm <sup>3</sup> (108 cu. in.)
Average Vertical Section at Saddle	2635 cm <sup>3</sup> (161 cu. in.)

### Draft Frame (drawbar)

Welded box construction machined for flatness with double ball-and-socket pivot connection equipped with quick-change replaceable wear inserts

### Circle

Welded construction, heat-treated, machined for flatness, equipped with quick-change replaceable wear inserts

Circle Diameter	1524 mm (60 in.)
Rotation	360 deg.
Drive	Hydraulic motor and worm gear with positive lock
Circle Side Shift (right and left)	787 mm (31 in.)

### Moldboard

High-strength, pre-stressed for higher strength, wear-resistant, high-carbon steel and reversible end bits; blade side-shift wear system includes quick-change replaceable wear inserts and quick-adjust jackscrew system

Base Length	4.27 m (14 ft. 0 in.)
Height (measured along arc, including cutting edge)	686 mm (27 in.)
Thickness	25 mm (1 in.)

### Cutting Edge

Dura-Max™ through-hardened steel edge	
Thickness	19 mm (0.75 in.)
Width	203 mm (8 in.)

<b>Scarifiers</b>		<b>870G/GP</b>	
		<i>Front</i>	<i>Mid-mount</i>
Type	Parallel-linkage V-type toolbar with manual 2-pitch positions, with hydraulic float		Radial linkage, with NeverGrease™ pin joints; V-type toolbar with manual 3-pitch positions, with hydraulic float
Width of Cut	1.20 m (4 ft. 0 in.)		1.19 m (3 ft. 11 in.)
Number of Shanks/Teeth	5 (maximum capacity 9)		11
Lift Above Ground	589 mm (23.2 in.)		335 mm (13.2 in.)
Maximum Penetration	335 mm (13.2 in.)		325 mm (12.8 in.)
Shank			
Spacing	146 mm (5.75 in.)		117 mm (4.6 in.)
Size	25 x 76 mm (1 x 3 in.)		25 x 76 mm (1 x 3 in.)
<b>Front Lift Group (Balderson-style)</b>			
Parallel linkage, mechanical pins, and hydraulic float			
Lift			
Above Ground (top of tube)	1864 mm (73.4 in.)		
Range	988 mm (38.9 in.)		
<b>Rear Ripper/Scarifier</b>			
Parallel linkage, with NeverGrease pin joints, hydraulic float, and integrated hitch			
		<i>Ripper</i>	<i>Scarifier</i>
Width of Cut	2.21 m (7 ft. 3 in.)		2.18 m (7 ft. 2 in.)
Number of Shanks/Teeth	3 (maximum capacity 5)		None standard (maximum capacity 9)
Lift Above Ground	602 mm (23.7 in.)		810 mm (31.9 in.)
Maximum Penetration	426 mm (16.8 in.)		323 mm (12.7 in.)
Shank Size	61.5 x 133 mm (2.42 x 5.25 in.)		25 x 76 mm (1 x 3 in.)
<b>Operator Station</b>			
Low-profile cab with ROPS (ISO 3471-2008) and FOPS (ISO 3449-2005)			
<b>Tires/Wheels</b>			
		<i>14R24 on 254-mm (10 in.) Rim</i>	<i>17.5R25 on 356-mm (14 in.) Rim</i>
Overall Width	2.49 m (98 in.)		2.64 m (104 in.)
Ground Clearance (front axle)	587 mm (23.1 in.)		587 mm (23.1 in.)
<b>Serviceability</b>			
<b>Refill Capacities</b>	<i>EPA Final Tier 4/EU Stage IV</i>		<i>EPA Tier 3/EU Stage IIIA and EPA Tier 2/EU Stage II</i>
Fuel Tank	416.5 L (110 gal.)		416.5 L (110 gal.)
Diesel Exhaust Fluid (DEF) Tank	22.5 L (6 gal.)		—
Cooling System	55.0 L (14.5 gal.)		48.5 L (12.8 gal.)
Engine Oil with Filter	27.0 L (7.1 gal.)		27.0 L (7.1 gal.)
Transmission Fluid	23.5 L (6.2 gal.)		28.4 L (7.5 gal.)
Differential Housing	38.0 L (10 gal.)		38.0 L (10 gal.)
Tandem Housings (each)	74.0 L (19.5 gal.)		74.0 L (19.5 gal.)
Circle Gearbox	5.7 L (1.5 gal.)		5.7 L (1.5 gal.)
Hydraulic Reservoir	60.5 L (16 gal.)		53.0 L (14 gal.)
<b>Operating Weights</b>			
With Full Fuel Tank, 4.27-m x 686-mm x 25-mm (14 ft. x 27 in. x 1.0 in.) Moldboard with 203-mm x 19-mm (8 in. x 3/4 in.) Cutting Edges, 17.5R25 L2 Tires, and 79-kg (175 lb.)			
Operator	<i>EPA Final Tier 4/EU Stage IV</i>		<i>EPA Tier 3/EU Stage IIIA and EPA Tier 2/EU Stage II</i>
Front	4531 kg (9,990 lb.)		4540 kg (10,010 lb.)
Rear	12 487 kg (27,530 lb.)		11 843 kg (26,110 lb.)
Total	17 019 kg (37,520 lb.)		16 384 kg (36,120 lb.)
Typical Operating Weight with Front Push Block, Rear Ripper/Scarifier, and Other Equipment			
Front	5788 kg (12,760 lb.)		5869 kg (12,940 lb.)
Rear	14 515 kg (32,000 lb.)		13 689 kg (30,179 lb.)
Total	20 303 kg (44,760 lb.)		19 558 kg (43,119 lb.)
Maximum Operating Weight	22 054 kg (48,620 lb.)		22 054 kg (48,620 lb.)

Option Weights	870G/GP
Moldboards with Through-Hardened Dura-Max Cutting Edge	
3.66 m x 686 mm x 25 mm (12 ft. x 27 in. x 1 in.) with 203-mm x 19-mm (8 in. x 3/4 in.) cutting edge and 16-mm (5/8 in.) hardware	- 126 kg (- 278 lb.)
3.96 m x 686 mm x 25 mm (13 ft. x 27 in. x 1 in.) with 203-mm x 19-mm (8 in. x 3/4 in.) cutting edge and 16-mm (5/8 in.) hardware	- 72 kg (- 159 lb.)
4.27 m x 686 mm x 25 mm (14 ft. x 27 in. x 1 in.) with 203-mm x 19-mm (8 in. x 3/4 in.) cutting edge and 16-mm (5/8 in.) hardware	0 kg (0 lb.)
4.27 m x 686 mm x 25 mm (14 ft. x 27 in. x 1 in.) with 203-mm x 19-mm (8 in. x 3/4 in.) cutting edge and 19-mm (3/4 in.) hardware	9.5 kg (21 lb.)
4.88 m x 686 mm x 25 mm (16 ft. x 27 in. x 1 in.) with 203-mm x 19-mm (8 in. x 3/4 in.) cutting edge and 19-mm (3/4 in.) hardware	137 kg (302 lb.)
Extensions, 610 mm (2 ft.) (right or left) For Use with 686-mm (27 in.) Moldboards	120.2 kg (265 lb.)
Overlay End Bits, Reversible (one pair) For 152-mm (6 in.) Cutting Edge	19.5 kg (43 lb.)
For 203-mm (8 in.) Cutting Edge	23.1 kg (51 lb.)
Circle-Drive Slip Clutch	9.1 kg (20 lb.)
Moldboard Impact-Absorption System	43.1 kg (95 lb.)
Ripper/Scarifier, Rear Mounted with Hitch and Ripper Shanks (3)	1139 kg (2,510 lb.)
Scarifier Shanks with Teeth (9 for rear ripper/scarifier)	68 kg (150 lb.)
Ripper Shanks and Teeth (2)	63 kg (139 lb.)
Rear Counterweight with Integral Rear Hitch	727.1 kg (1,603 lb.)
Rear Hitch	54.4 kg (120 lb.)
Push Block, Front	1338 kg (2,950 lb.)
Scarifier	
Front Mount with Teeth (5)	831.4 kg (1,833 lb.)
Mid-Mount with Teeth (11)	1481 kg (3,265 lb.)
Front Lift Group (Balderson-style)	762.9 kg (1,682 lb.)

Machine Dimensions	
A Height to Top of Cab	3.18 m (10 ft. 5 in.)
A <sup>1</sup> Height to Top of Full-Height Cab	3.40 m (11 ft. 2 in.)
B Height to Top of Exhaust	3.10 m (10 ft. 2 in.)
C Height to Top of Blade-Lift Cylinders	3.05 m (10 ft. 0 in.)
D Tandem Axle Spacing	1.54 m (5 ft. 1 in.)
E Blade Base	2.53 m (8 ft. 4 in.)

Option Weights (continued)	870G/GP
Dozer Blade, Front Mounted	
2667 mm x 955 mm (105 in. x 37.6 in.)	590 kg (1,301 lb.)
2921 mm x 955 mm (115 in. x 37.6 in.)	648 kg (1,429 lb.)
Tires	
14.00-24, 12 PR G2	- 272.2 kg (- 600 lb.)
17.5-25, 12 PR G2/L2	- 157.9 kg (- 348 lb.)
14.00-R24, Radial, G2/L2 General Purpose	- 51.7 kg (- 114 lb.)
14.00-R24, Radial, G2/L2 Snow	- 10.9 kg (- 24 lb.)
17.5-R25, Radial, L2 General Purpose	0 kg (0 lb.)
17.5-R25, Radial, G2/L2 Snow	43.5 kg (96 lb.)
17.5-R25, Radial, G3/L3 General Purpose	89.8 kg (198 lb.)
550/65R25 XLD70 G3/L3 Radial, General Purpose	443.6 kg (978 lb.)
Multi-Piece Rims	
254 mm x 610 mm (10 in. x 24 in.)	- 87.1 kg (- 192 lb.)
356 mm x 635 mm (14 in. x 25 in.)	0 kg (0 lb.)
Fenders	
Front	76.7 kg (169 lb.)
Rear	140.6 kg (310 lb.)
Cab, Low with Opening Front and Side Windows	14.5 kg (32 lb.)
Premium Air-Suspension, Heated Seat with Adjustable Arm- and Headrests	12.7 kg (28 lb.)
Fast-Fill Fuel System	13.6 kg (30 lb.)
Quick Service	10.9 kg (24 lb.)
Sound-Absorption Package (machines equipped with Tier 3/Stage IIIA and Tier 2/Stage II engines only)	14.1 kg (31 lb.)
Secondary Steering	26.3 kg (58 lb.)
Beacon Bracket	8.2 kg (18 lb.)
Fire Extinguisher	14.5 kg (32 lb.)
Lighting Packages	
10 Halogen Lights	4.5 kg (10 lb.)
16 Halogen Lights	7.3 kg (16 lb.)
18 Halogen and/or LED Lights	8.2 kg (18 lb.)
High-Front Light Bar for Snowplowing	20 kg (44 lb.)
Auxiliary Hydraulic Control Valve Section and Controls	6.8 kg (15 lb.)
Hydraulics for Front-Mounted Equipment	8.6 kg (19 lb.)

Machine Dimensions (continued)	
F Wheelbase	6.16 m (20 ft. 3 in.)
G Overall Length	8.89 m (29 ft. 2 in.)
H Overall Length with Scarifier	9.69 m (31 ft. 9 in.)
I Overall Length with Push Block and Ripper	9.99 m (32 ft. 9 in.)
II Overall Length with Scarifier and Ripper	10.59 m (34 ft. 9 in.)

For Overall Width see Tires/Wheels on page 34.

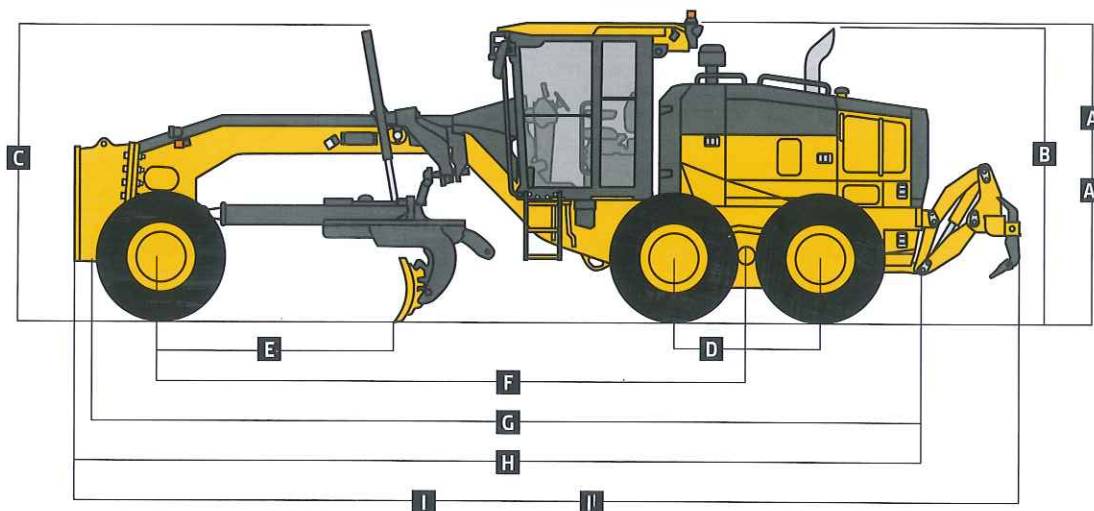

# 872G/GP



Engine	872G/GP		
Manufacturer and Model	John Deere PowerTech™ PSS 9.0L	John Deere PowerTech™ Plus 9.0L	John Deere PowerTech™ 9.0L
Non-Road Emissions Standard	EPA Final Tier 4/EU Stage IV	EPA Tier 3/EU Stage IIIA	EPA Tier 2/EU Stage II
Cylinders	6	6	6
Displacement	9.0L (548 cu. in.)	9.0L (548 cu. in.)	9.0L (548 cu. in.)
Net Engine Power			
Gear 1 (6WD on)	175 kW (235 hp)	160 kW (214 hp)	160 kW (214 hp)
Gear 2 (6WD on)	186 kW (250 hp)	163 kW (219 hp)	163 kW (219 hp)
Gear 3 (6WD on)	198 kW (265 hp)	180 kW (241 hp)	180 kW (241 hp)
Gear 4 (6WD on)	205 kW (275 hp)	180 kW (241 hp)	180 kW (241 hp)
Gear 5 (6WD on)	209 kW (280 hp)	187 kW (250 hp)	187 kW (250 hp)
Gear 6 (6WD on)	216 kW (290 hp)	205 kW (275 hp)	205 kW (275 hp)
Gear 7 (6WD on)	224 kW (300 hp)	205 kW (275 hp)	205 kW (275 hp)
Gear 8	216 kW (290 hp)	200 kW (268 hp)	200 kW (268 hp)
Net Peak Torque	1459 Nm (1,076 lb.-ft.)	1353 Nm (998 lb.-ft.)	1353 Nm (998 lb.-ft.)
Net Torque Rise	51%	53%	53%
Aspiration	Series turbocharged, charge-air cooled	Turbocharged, charge-air cooled	Turbocharged, charge-air cooled
Lubrication	Full-flow spin-on filter and integral cooler	Full-flow spin-on filter and integral cooler	Full-flow spin-on filter and integral cooler
Air Cleaner with Restriction Indicator	Dual element, dry	Dual element, dry	Dual element, dry
<b>Cooling</b>			
Cooling-on-demand, hydraulic-driven, variable-speed fan drive to optimize fuel consumption; standard auto-reversing fan to keep coolers clean; swing-out rear fan door and pivoting or foldout coolers for easy cleaning of all cooling components			
Engine Coolant, Extended Life, Rating	-37 deg. C (-34 deg. F)		
<b>Powertrain</b>			
<b>6-Wheel Drive</b>	Automatic dual-path hydrostatic drive; increases tractive effort and front-end control; includes separate left and right systems with variable-displacement pumps, axial-piston wheel motors, and freewheel at transport speeds; operator-selectable 15-position rotary aggressiveness control and inching capability down to 0 mph; precision mode (propelled by front wheels only)		
6-Wheel-Drive Effective Gears	1-7 forward and reverse		
Precision Mode			
Effective Gears	1-3 forward only		
Operating Speeds	0.4-8.0 km/h (0.25-5.0 mph)		
Hydrostatic Pumps (2 each)	64 cm³ (3.9 cu. in.)		
Wheel Motors	60 cm³ (3.7 cu. in.)		
Final Reduction	38.7:1		
<b>Transmission</b>	Direct-drive John Deere PowerShift Plus™, modulated shift-on-the-go, Event-Based Shifting (EBS), inching pedal; independent transmission reservoir with separate filtration and cooling system with 121-L/min. (32 gpm) gear pump		
Gears			
Forward	8		
Reverse	8		
<b>Maximum Travel Speeds (forward and reverse)</b>	<i>With no tire slip at 2,180 rpm, 14R24 tires</i>		
Gear 1	3.9 km/h (2.4 mph)		
Gear 2	5.6 km/h (3.5 mph)		
Gear 3	7.9 km/h (4.9 mph)		
Gear 4	10.9 km/h (6.8 mph)		
Gear 5	16.7 km/h (10.4 mph)		
Gear 6	23.3 km/h (14.5 mph)		
Gear 7	32.2 km/h (20.0 mph)		
Gear 8	45.0 km/h (28.0 mph)		
<b>Front Axle</b>	Heavy-duty welded fabrication		
Oscillation (total)	32 deg.		
Wheel Lean Angle (each direction)	20 deg.		
<b>Differentials</b>	Spiral bevel; hydraulically actuated, clutch type can be applied on-the-go; selectable manual or automatic differential lock		
<b>Steering</b> (all models include steering wheel)	All-hydraulic power-frame articulation for maneuverability and productivity; crab steering reduces side drift, positions tandems on firm ground, and increases side-slope stability; return-to-straight control included in Grade Pro (GP) option		
Turning Radius (front steer and articulation)	7.21 m (23 ft. 8 in.)		
Articulation (both right and left)	22 deg.		
<b>Final Drives</b>	Inboard-mounted planetary sealed in cooled, filtered oil		



<b>Powertrain</b> (continued)	<b>872G/GP</b>
<b>Brakes</b>	Foot-controlled, hydraulically operated, multiple wet-disc brakes sealed in pressurized, cooled, filtered oil; both independent systems effective on all 4 tandem wheels
Primary and Secondary Brakes	Hydraulically actuated, inboard of tandem pivot, self-adjusting, sealed in cooled and filtered oil, multi-disc (ISO 3450)
Parking Brake	Automatically spring applied, hydraulically released, oil cooled, self-adjusting (ISO 3450)
<b>Hydraulics</b>	
Closed-center, pressure-compensated load-sensing (PCLS), variable-displacement piston pump	
Maximum Pump Flow	218 L/min. (57.5 gpm)
Maximum System Pressure	18 961 kPa (2,750 psi)
Pump Displacement	90 cm <sup>3</sup> (5.5 cu. in.)
<b>Blade Function</b>	
All-hydraulic, industry-standard lever placement of blade-function controls; includes float position; 7 discrete saddle positions	
<b>Blade Range</b>	
Lift Above Ground	452 mm (17.8 in.)
Blade Side Shift (right or left)	683 mm (26.9 in.)
Pitch at Ground Line	
Forward	42 deg.
Back	5 deg.
Shoulder Reach Outside Wheels (frame straight, right or left)	2329 mm (7 ft. 8 in.)
Bank Cut Angle (right or left)	90 deg.
<b>Productivity</b>	
Blade Pull (maximum weight [22 054 kg (48,620 lb.)], 0.9 coefficient of traction)	18 082 kg (39,864 lb.)
<b>Electrical</b>	
Solid-state load center and sealed-switch module	
Voltage	24 volt
Number of Batteries	2
Battery Capacity	1,400 CCA
Reserve Capacity	440 min.
Amp-Hour Rating	224 amp-hour
Alternator Rating	100 / 130 / 200 amp
Lights	Driving lights; 2 high- and 2 low-beam halogen headlights; front and rear LED turn signals and marker lights; LED brake and hazard warning lights
<b>Mainframe</b>	
Type	Welded box construction
Width (minimum)	307 mm (12.1 in.)
Height (minimum)	307 mm (12.1 in.)
Thickness	
Side	16 mm (0.63 in.)
Top and Bottom Plate	30 mm (1.17 in.)
Modulus	
Minimum Vertical Section	1770 cm <sup>3</sup> (108 cu. in.)
Average Vertical Section at Saddle	2635 cm <sup>3</sup> (161 cu. in.)
<b>Draft Frame (drawbar)</b>	
Welded box construction machined for flatness with double ball-and-socket pivot connection equipped with quick-change replaceable wear inserts	
<b>Circle</b>	
Welded construction, heat-treated, machined for flatness, equipped with quick-change replaceable wear inserts	
Circle Diameter	1524 mm (60 in.)
Rotation	360 deg.
Drive	Hydraulic motor and worm gear with positive lock
Circle Side Shift (right and left)	787 mm (31 in.)
<b>Moldboard</b>	
High-strength, pre-stressed for higher strength, wear-resistant, high-carbon steel and reversible end bits; blade side-shift wear system includes quick-change replaceable wear inserts and quick-adjust jackscrew system	
Base Length	4.27 m (14 ft. 0 in.)
Height (measured along arc, including cutting edge)	686 mm (27 in.)
Thickness	25 mm (1.00 in.)

<b>Cutting Edge</b>		<b>872G/GP</b>
Dura-Max™ through-hardened steel edge		
Thickness	19 mm (0.75 in.)	
Width	203 mm (8 in.)	
<b>Scarifiers</b>		
	<i>Front</i>	<i>Mid-mount</i>
Type	Parallel-linkage V-type toolbar with manual 2-pitch positions, with hydraulic float	Radial linkage, with NeverGrease™ pin joints; V-type toolbar with manual 3-pitch positions, with hydraulic float
Width of Cut	1.20 m (4 ft. 0 in.)	1.19 m (3 ft. 11 in.)
Number of Shanks/Teeth	5 (maximum capacity 9)	11
Lift Above Ground	589 mm (23.2 in.)	335 mm (13.2 in.)
Maximum Penetration	335 mm (13.2 in.)	325 mm (12.8 in.)
Shank		
Spacing	146 mm (5.75 in.)	117 mm (4.6 in.)
Size	25 x 76 mm (1 x 3 in.)	25 x 76 mm (1 x 3 in.)
<b>Front Lift Group (Balderson-style)</b>		
Parallel linkage, mechanical pins, and hydraulic float		
Lift		
Above Ground (top of tube)	1864 mm (73.4 in.)	
Range	988 mm (38.9 in.)	
<b>Rear Ripper/Scarifier</b>		
Parallel linkage, with NeverGrease pin joints, hydraulic float, and integrated hitch		
	<i>Ripper</i>	<i>Scarifier</i>
Width of Cut	2.21 m (7 ft. 3 in.)	2.18 m (7 ft. 2 in.)
Number of Shanks/Teeth	3 (maximum capacity 5)	None standard (maximum capacity 9)
Lift Above Ground	602 mm (23.7 in.)	810 mm (31.9 in.)
Maximum Penetration	426 mm (16.8 in.)	323 mm (12.7 in.)
Shank Size	61.5 x 133 mm (2.42 x 5.25 in.)	25 x 76 mm (1 x 3 in.)
<b>Operator Station</b>		
Low-profile cab with ROPS (ISO 3471-2008) and FOPS (ISO 3449-2005)		
<b>Tires/Wheels</b>		
	<i>14R24 on 254-mm (10 in.) Rim</i>	<i>17.5R25 on 356-mm (14 in.) Rim</i>
Overall Width	2.49 m (98 in.)	2.64 m (104 in.)
Ground Clearance (front axle)	587 mm (23.1 in.)	587 mm (23.1 in.)
<b>Serviceability</b>		
<b>Refill Capacities</b>	<i>EPA Final Tier 4/EU Stage IV</i>	<i>EPA Tier 3/EU Stage IIIA and EPA Tier 2/EU Stage II</i>
Fuel Tank	416.5 L (110 gal.)	416.5 L (110 gal.)
Diesel Exhaust Fluid (DEF) Tank	22.5 L (6 gal.)	—
Cooling System	55.0 L (14.5 gal.)	48.5 L (12.8 gal.)
Engine Oil with Filter	27.0 L (7.1 gal.)	27.0 L (7.1 gal.)
Transmission Fluid	23.5 L (6.2 gal.)	28.4 L (7.5 gal.)
Differential Housing	38.0 L (10 gal.)	38.0 L (10 gal.)
Tandem Housings (each)	74.0 L (19.5 gal.)	74.0 L (19.5 gal.)
Circle Gearbox	5.7 L (1.5 gal.)	5.7 L (1.5 gal.)
Hydraulic Reservoir	60.5 L (16 gal.)	53.0 L (14 gal.)
<b>Operating Weights</b>		
With Full Fuel Tank, 4.27-m x 686-mm x 25-mm (14 ft. x 27 in. x 1.0 in.) Moldboard with 203-mm x 19-mm (8 in. x 3/4 in.) Cutting Edges, 17.5R25 L2 Tires, and 79-kg (175 lb.)		
Operator	<i>EPA Final Tier 4/EU Stage IV</i>	<i>EPA Tier 3/EU Stage IIIA and EPA Tier 2/EU Stage II</i>
Front	5094 kg (11,230 lb.)	5103 kg (11,250 lb.)
Rear	12 891 kg (28,420 lb.)	12 242 kg (26,990 lb.)
Total	17 985 kg (39,650 lb.)	17 345 kg (38,240 lb.)
Typical Operating Weight with Front Push Block, Rear Ripper/Scarifier, and Other Equipment		
Front	6323 kg (13,940 lb.)	6407 kg (14,124 lb.)
Rear	14 864 kg (32,770 lb.)	14 036 kg (30,944 lb.)
Total	21 187 kg (46,710 lb.)	20 443 kg (45,068 lb.)
Maximum Operating Weight	22 054 kg (48,620 lb.)	22 054 kg (48,620 lb.)

Option Weights	872G/GP
Moldboards with Through-Hardened Dura-Max Cutting Edge	
3.66 m x 686 mm x 25 mm (12 ft. x 27 in. x 1 in.) with 203-mm x 19-mm (8 in. x 3/4 in.) cutting edge and 16-mm (5/8 in.) hardware	- 126 kg (- 278 lb.)
3.96 m x 686 mm x 25 mm (13 ft. x 27 in. x 1 in.) with 203-mm x 19-mm (8 in. x 3/4 in.) cutting edge and 16-mm (5/8 in.) hardware	- 72 kg (- 159 lb.)
4.27 m x 686 mm x 25 mm (14 ft. x 27 in. x 1 in.) with 203-mm x 19-mm (8 in. x 3/4 in.) cutting edge and 16-mm (5/8 in.) hardware	0 kg (0 lb.)
4.27 m x 686 mm x 25 mm (14 ft. x 27 in. x 1 in.) with 203-mm x 19-mm (8 in. x 3/4 in.) cutting edge and 19-mm (3/4 in.) hardware	9.5 kg (21 lb.)
4.88 m x 686 mm x 25 mm (16 ft. x 27 in. x 1 in.) with 203-mm x 19-mm (8 in. x 3/4 in.) cutting edge and 19-mm (3/4 in.) hardware	137 kg (302 lb.)
Extensions, 610 mm (2 ft.) (right or left)	
For Use with 686-mm (27 in.) Moldboards	120.2 kg (265 lb.)
Overlay End Bits, Reversible (one pair)	
For 152-mm (6 in.) Cutting Edge	19.5 kg (43 lb.)
For 203-mm (8 in.) Cutting Edge	23.1 kg (51 lb.)
Circle-Drive Slip Clutch	9.1 kg (20 lb.)
Moldboard Impact-Absorption System	43.1 kg (95 lb.)
Ripper/Scarifier, Rear Mounted with Hitch and Ripper Shanks (3)	1139 kg (2,510 lb.)
Scarifier Shanks with Teeth (9 for rear ripper/scarifier)	68 kg (150 lb.)
Ripper Shanks and Teeth (2)	63 kg (139 lb.)
Rear Counterweight with Integral Rear Hitch	727.1 kg (1,603 lb.)
Rear Hitch	54.4 kg (120 lb.)
Push Block, Front	1338 kg (2,950 lb.)
Scarifier	
Front Mount with Teeth (5)	831.4 kg (1,833 lb.)
Mid-Mount with Teeth (11)	1481 kg (3,265 lb.)
Front Lift Group (Balderson-style)	762.9 kg (1,682 lb.)

Option Weights (continued)	872G/GP
Dozer Blade, Front Mounted	
2667 mm x 955 mm (105 in. x 37.6 in.)	590 kg (1,301 lb.)
2921 mm x 955 mm (115 in. x 37.6 in.)	648 kg (1,429 lb.)
Tires	
14.00-24, 12 PR G2	- 272.2 kg (- 600 lb.)
17.5-25, 12 PR G2/L2	- 157.9 kg (- 348 lb.)
14.00-R24, Radial, G2/L2 General Purpose	- 51.7 kg (- 114 lb.)
14.00-R24, Radial, G2/L2 Snow	- 10.9 kg (- 24 lb.)
17.5-R25, Radial, L2 General Purpose	0 kg (0 lb.)
17.5-R25, Radial, G2/L2 Snow	43.5 kg (96 lb.)
17.5-R25, Radial, G3/L3 General Purpose	89.8 kg (198 lb.)
550/65R25 XLD70 G3/L3 Radial, General Purpose	443.6 kg (978 lb.)
Multi-Piece Rims	
254 mm x 610 mm (10 in. x 24 in.)	- 85.3 kg (- 188 lb.)
356 mm x 635 mm (14 in. x 25 in.)	0 kg (0 lb.)
Fenders	
Front	76.7 kg (169 lb.)
Rear	140.6 kg (310 lb.)
Cab, Low with Opening Front and Side Windows	14.5 kg (32 lb.)
Premium Air-Suspension, Heated Seat with Adjustable Arm- and Headrests	12.7 kg (28 lb.)
Fast-Fill Fuel System	13.6 kg (30 lb.)
Quick Service	10.9 kg (24 lb.)
Sound-Absorption Package (machines equipped with Tier 3/Stage IIIA and Tier 2/Stage II engines only)	14.1 kg (31 lb.)
Secondary Steering	26.3 kg (58 lb.)
Beacon Bracket	8.2 kg (18 lb.)
Fire Extinguisher	14.5 kg (32 lb.)
Lighting Packages	
10 Halogen Lights	4.5 kg (10 lb.)
16 Halogen Lights	7.3 kg (16 lb.)
18 Halogen and/or LED Lights	8.2 kg (18 lb.)
High-Front Light Bar for Snowplowing	20 kg (44 lb.)
Auxiliary Hydraulic Control Valve Section and Controls	6.8 kg (15 lb.)
Hydraulics for Front-Mounted Equipment	8.6 kg (19 lb.)

#### Machine Dimensions

A Height to Top of Cab	3.18 m (10 ft. 5 in.)
A' Height to Top of Full-Height Cab	3.40 m (11 ft. 2 in.)
B Height to Top of Exhaust	3.13 m (10 ft. 3 in.)
C Height to Top of Blade-Lift Cylinders	3.05 m (10 ft. 0 in.)
D Tandem Axle Spacing	1.54 m (5 ft. 1 in.)
E Blade Base	2.53 m (8 ft. 4 in.)

#### Machine Dimensions (continued)

F Wheelbase	6.16 m (20 ft. 3 in.)
G Overall Length	8.89 m (29 ft. 2 in.)
H Overall Length with Scarifier	9.69 m (31 ft. 9 in.)
I Overall Length with Push Block and Ripper	9.99 m (32 ft. 9 in.)
I' Overall Length with Scarifier and Ripper	10.59 m (34 ft. 9 in.)

For Overall Width see Tires/Wheels on page 38.

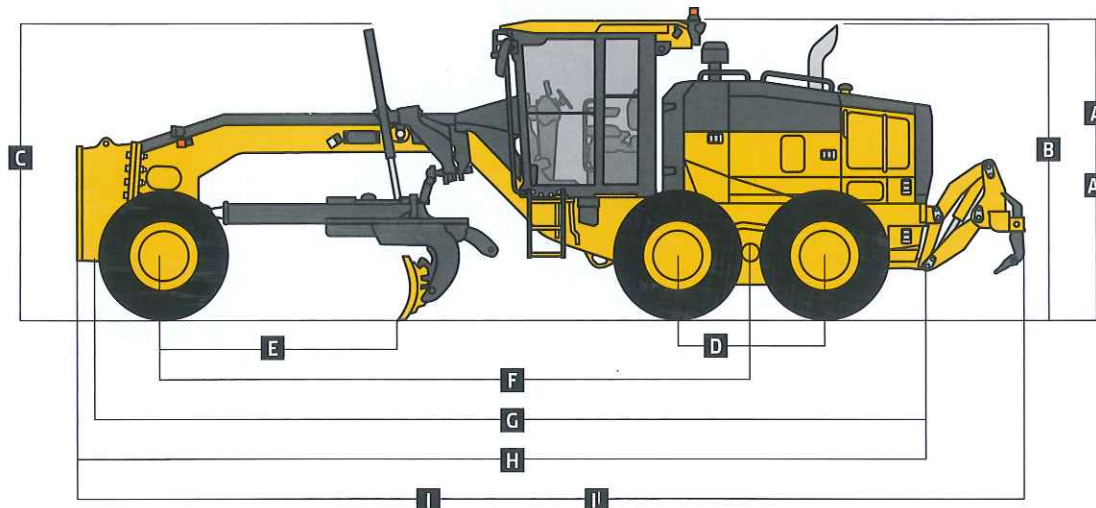

# Additional equipment

Key: ● Standard ▲ Optional or special

See your John Deere dealer for further information.

670/ 672	770/ 772	870/ 872	Operator's Station
●	●	●	Low-profile ROPS/FOPS cab with HVAC (ROPS ISO 3471 / FOPS SAE 3449 Level II)
▲	▲	▲	Low-profile ROPS/FOPS cab utilizing laminated glass with fixed lower front and side opening windows
▲	▲	▲	Opening front and side windows (standard with Grade Pro)
●	●	●	Keyless start with multiple security modes
●	●	●	Fabric air-suspension seat with armrests and headrest
▲	▲	▲	Premium heated, leather/fabric, high-wide back, air-suspension seat with armrests (standard with Grade Pro)
●	●	●	Sealed-switch module with function indicators
●	●	●	Electric rear-window defroster
●	●	●	Upper front and rear windshield washers with intermittent wipers
▲	▲	▲	Lower front intermittent wiper and washer
▲	▲	▲	Powered cab precleaner
▲	▲	▲	Decelerator pedal
▲	▲	▲	Flip-down, right- and/or left-hand cab beacon with bracket
●	●	●	Cab prewired for beacon, radio, and auxiliary circuit
▲	▲	▲	Front window sun visor / retractable rear sunshade
●	●	●	Rearview mirrors, exterior (2) (SAE J985)
▲	▲	▲	Heated exterior mirrors (2) (SAE J985)
▲	▲	▲	Fire extinguisher
▲	▲	▲	High-resolution rearview camera with dedicated monitor
●	●	●	Retractable seat belt, 76 mm (3 in.) (SAE 386)
▲	▲	▲	AM/FM radio with auxiliary and weatherband
▲	▲	▲	AM/FM radio with Bluetooth®, auxiliary, weatherband, and XM Satellite Radio™ ready
●	●	●	Push-button-activated cruise control
			<b>Electrical</b>
●	●	●	100-amp alternator
▲	▲	▲	130-amp alternator
▲	▲	▲	200-amp alternator (FT4/Stage IV)
●	●	●	Batteries (2), 1,400 CCA with 440-min. reserve capacity
●	●	●	Left-hand engine compartment service-check light
▲	▲	▲	Right-hand engine compartment service-check light
●	●	●	Transporting lights (4 halogen transport lights)
▲	▲	▲	Grading lights (10 halogen lights)
▲	▲	▲	Deluxe grading lights (18 halogen lights)

670/ 672	770/ 772	870/ 872	Electrical (continued)
▲	▲	▲	Premium grading lights (18 LED lights)
▲	▲	▲	Tall front snowplow light bar
●	●	●	Multifunction/multi-language diagnostic LCD color monitor
●	●	●	Reverse warning alarm (SAE J994)
●	●	●	LED brake and turn lights
			<b>Moldboard</b>
			<b>Patented pre-stressed, high strength, wear resistant:</b>
●	●		3.66-m x 610-mm x 22-mm (12 ft. x 24 in. x 7/8 in.)
▲	▲	▲	3.66-m x 686-mm x 25-mm (12 ft. x 27 in. x 1 in.)
▲	▲	▲	3.96-m x 686-mm x 25-mm (13 ft. x 27 in. x 1 in.)
▲	▲		4.27-m x 610-mm x 22-mm (14 ft. x 24 in. x 7/8 in.)
▲	▲	●	4.27-m x 686-mm x 25-mm (14 ft. x 27 in. x 1 in.)
		▲	4.88-m x 686-mm x 25-mm (16 ft. x 27 in. x 1 in.)
●	●	●	Quick-change and jackscrew-adjustable moldboard side-shift extreme-duty wear inserts
▲	▲		610-mm (24 in.) left- or right-hand extensions for 610-mm (24 in.) moldboard
	▲	▲	610-mm (24 in.) left- or right-hand extensions for 686-mm (27 in.) moldboard
▲	▲	▲	Reversible overlay endbits
			<b>Overall Vehicle</b>
●	●	●	JDLink™ Ultimate wireless communication system (available in specific countries; see your dealer for details)
●	●	●	Ground-level fuel and Diesel Exhaust Fluid (DEF) filling
▲	▲	▲	Fast-fill fuel system
●	●	●	Fluid-sampling ports for engine oil and coolant, hydraulic oil, and axle and transmission fluids
●	●	●	Vandal-protection locking for: Cab doors / Top tank radiator-access door / Engine coolant surge tank / Hydraulic reservoir cap / Battery-disconnect switch / Ground-level electrical master disconnect switch / Fuel-tank door and cap / Toolbox
●	●	●	Environmental drains with hoses for engine, transmission, hydraulic, differential fluids, and engine coolant
●	●	●	Hydraulically driven cool-on-demand reversing fan
●	●	●	Banked easy-access vertical spin-on filters for hydraulic, transmission, and axle fluids
●	●	●	Engine rotary ejector precleaner
●	●	●	Automatic differential lock

670/ 672	770/ 772	870/ 872	Overall Vehicle (continued)
●	●	●	Engine-stall prevention and auto-shutdown
▲	▲	▲	Adjustable rotary engine precleaner (FT4/Stage IV)
▲	●	●	Heavy-duty air cleaner (FT4/Stage IV)
●	●		Single-input circle drive
▲	▲		Single-input circle drive with slip clutch
▲	▲	●	Heavy-duty dual-input circle drive without slip clutch
▲	▲	▲	Heavy-duty dual-input circle drive with slip clutch
▲	▲	▲	AutoShift transmission
▲	▲	▲	Blade-impact-absorption system
▲	▲	▲	Front and/or rear wheel fenders
▲	▲	▲	Quick-service bank for transmission, hydraulic, engine oil, and engine coolant fluid changes
▲	▲	▲	Secondary steering
▲	▲	▲	Sound-absorption package (Tier 3/ Stage IIIA and Tier 2/Stage II)
			<b>Front Attachments</b>
▲	▲	▲	Front push block
▲	▲	▲	V-type front scarifier with float position, 5 shanks
▲	▲	▲	Mid-mount scarifier with float position, 11 shanks
▲	▲	▲	Front Balderson-style lift group with float position
▲	▲	▲	Front-mounted dozer blades (3 different widths)
			<b>Rear Attachments</b>
●	●	●	Full bottom guard with access panel and side guards for rear vehicle protection
▲	▲	▲	Rear-mounted ripper/scarifier combination with rear hitch and pin, 3 ripper shanks
▲	▲	▲	Rear counterweight with rear hitch and pin
▲	▲	▲	Rear hitch and pin
▲	▲	▲	Extra scarifier shanks (9) with teeth for rear ripper scarifier
▲	▲	▲	Extra ripper shanks (2) with teeth for rear ripper/scarifier
			<b>Grade Pro (GP) Option</b>
●	●	●	Low-profile Grade Pro cab with opening lower front and side windows
▲	▲	▲	Low-profile Grade Pro cab utilizing laminated glass with fixed lower front and side opening windows
●	●	●	Premium heated, leather/fabric, high wide-back air-suspension seat with armrests
●	●	●	Fingertip armrest-mounted controls including steering lever
●	●	●	Cross-slope
●	●	●	Return to straight
●	●	●	Grade-control-ready package
▲	▲	▲	Topcon integrated grade control

Net engine power is with standard equipment including air cleaner, exhaust system, alternator, and cooling fan at test conditions specified per ISO9249. No derating is required up to 3050-m (10,000 ft.) altitude. Specifications and design subject to change without notice. Wherever applicable, specifications are in accordance with SAE standards. Except where otherwise noted, these specifications are based on units with standard equipment; 14.0 x 610-mm (24 in.) 12 PR C2, Bias tires and 3.66-m x 610-mm x 22-mm (12 ft. x 24 in. x 7/8 in.) high-strength, wear-resistant moldboards with 16-mm x 152-mm (0.63 in. x 6 in.) Dura-Max™ through-hardened-steel cutting edges for the 670G, 672G, 770G, and 772G; and 17.5 R 635-mm (25 in.) L2, Radial tires, and 4.27-m x 688-mm x 25-mm (14 ft. x 27 in. x 1 in.) high-strength, wear-resistant moldboards with 16-mm x 152-mm (0.63 in. x 6 in.) Dura-Max through-hardened-steel cutting edges for the 870G and 872G. Weights include lubricants, coolants, full fuel tanks, and 79-kg (175 lb.) operators.

