

ENGINE - VHP

Model	FPT F4HE9687C, Tier 3 certified
	Compliant w/ EPA regulations effective January 2011 Electronic control
Type	4-stroke, turbocharged and air to air cooled
Cylinders	6, in-line
Bore/Stroke	4.09 in x 5.17 in (104 mm x 132 mm)
Displacement	409 in ³ (6.7 L)
Fuel injection	Common rail
Fuel	Diesel
Cooling	Liquid
Horsepower @ 2200 RPM – SAE J1995:	
Gross	193/205/220 hp (144/153/164 kW)
Net	178/190/205 hp (133/142/153 kW)
Maximum torque @ 1500 RPM:	
	612/649/686 ft-lb (830/880/930 N-m)

DRIVETRAIN

Rear axle	Graziano, planetary
Differential	Hydraulic lock, operator controlled
Inboard brakes	Wet disc
Number of discs / brake	5
Brake surface area	2,220 in ² (14 326 cm ²)
Tandems:	
Type	Welded plate
Oscillation	20° each way
Front axle	High strength, welded steel
Oscillation	15.3° each direction
Wheel lean	20° left/right
Tires – standard	14.0 x 24 12PR TL G2 Firestone
Rims	1-piece 9 in x 24 in (227 mm x 610 mm)
Transmission type:	
	Direct drive countershaft powershift w/ electronic shift control and inching pedal
Pump flow @ 2200 RPM	29.5 gpm (112 L/min)
Sump	Integral
Speeds	8 forward/4 reverse
Shifting	Single lever, bump style automatic electronic control
Diagnostics	On-board

DRIVETRAIN (cont.)

Speeds:	
Forward:	mph (km/h)
1st	2.7 (4.3)
2nd	3.7 (6.0)
3rd	5.2 (8.4)
4th	7.3 (11.8)
5th	10.4 (16.7)
6th	14.4 (23.1)
7th	20.2 (32.5)
8th	27.8 (44.8)
Reverse:	mph (km/h)
1st	2.5 (4.0)
2nd	5.0 (8.0)
3rd	9.8 (15.8)
4th	19.3 (31.0)

ELECTRICAL

Voltage	24 Volts, negative ground
Alternator	90 amp
Batteries	(2) Low-maintenance 1010 CCA – 100 Ah (20 hr rate)
Work lights:	
Headlights (2); Turn signals, front/rear; Stop/tail (2); Rear mounted floods (2); Front mounted floods (2).	
Backup alarm	Standard

OPERATOR ENVIRONMENT

ROPS/FOPS cab – SAE J231, ISO 3449;
Adjustable operator's console; Adjustable cloth
suspension seat w/ 3 in (76 mm) retractable
seat belt; Safety glass; Dome light; Inside
rearview mirror; Outside rearview mirrors; Cup
holder; Storage tray; 12-volt outlet; Radio ready
– 12 Volt; Electrical master switch – automatic;
Heater/defroster/pressurizer; Air conditioner;
Sound suppression; Cab doors – left/right;
Steps – left/right; Steering wheel;
Windshield wiper – front; Windshield
washer – front.

OPERATING WEIGHT

W/ 14 ft (4.27 m) moldboard, 17.5-25 tires, front counterweight, 175 lb (79 kg) operator and full fuel:	33,796 lb (15 330 kg)
Weight, front axle	10,141 lb (4 600 kg)
Weight, rear axle	23,655 lb (10 730 kg)
Blade pressure	20,626 lb (9 356 kg)

HYDRAULICS

System design	Closed center, load sensing
Hydraulic pump	Load sensing piston pump, variable displacement, pressure and flow compensated
Rated flow @ 2200 RPM	49 gpm (187 L/min)
Control valve	9 section
Side shift and pitch	Hydraulic
Saddle	5 positions
Diagnostic quick couplers	8

SERVICE CAPACITIES

Engine	4.4 gal (17.5 L)
w/ filter change	4.7 gal (18.5 L)
Fuel	90 gal (341 L)
Transmission	5.0 gal (23 L)
w/ filter change	6.6 gal (25 L)
Radiator	10.5 gal (40 L)
Hydraulic reservoir	24 gal (90 L)
Hydraulic system	50.2 gal (190 L)
Circle gearbox	3 qt (2.8 L)
Rear axle center	11.6 gal (44 L)
Total axle	11.6 gal (44 L)
Tandem case, each	15.9 gal (60 L)

OTHER SPECIFICATIONS

Steering:

Type	Hydrostatic power steering
Turns – lock-to-lock	4.75
Pump capacity @ 2200 engine RPM:	
	11.1 gpm (41.8 L/min)
Relief pressure	2200 psi (151 bar) Integral w/ priority valve

Cylinder (2):

	2.0 in bore x 11.85 in stroke x 1.0 in rod dia. (50.8 mm x 301.0 mm x 25.4 mm)
Supplemental steering	Integral

Articulation:

Type	Hydraulic actuated – w/ lock valve
Range	25° left/right
Controls	Hydraulic

MAINFRAME

Type	All welded box
Front section:	
Size	10.0 in x 11.73 in (254 mm x 298 mm)
Weight – each side	124.7 lb-ft (172.8 kg/m)
Rear section:	
Size	4.75 in x 11.75 in (121 mm x 299 mm)
Weight – each side	55.6 lb-ft (84.0 kg/m)

DRAWBAR

Type:	"A" frame welded construction with center mounted circle turn motor
Ball and circle	Shim adjustable

MOLDBOARD

Type	High-carbon steel
Shape	Involute curve
Length	14 ft 0 in (4 267 mm)
Height	23.6 in (600 mm)
Thickness	0.875 in (22 mm)
End bits	2, interchangeable
Blade pitch positions:	
Normal pitch	47°
Minimum pitch	42°
Maximum pitch	87°
Blade shift:	
Right	27.0 in (686 mm)
Left	21.0 in (533 mm)
Max. bank cutting angle:	
Right	90°
Left	90°
Max. ground penetration	28 in (711.2 mm)
Max. lift above ground	17.5 in (444.5 mm)

CIRCLE

Type	Welded construction
Diameter:	
Max. outside	69.0 in (1 752 mm)
Vertical member	63.0 in (1 600 mm)
Rotation	360°
Speed	1.2 RPM (7.2°/second)
Drive	
Type	Hydraulic motor
Displacement	Roller geroter 15.26 in ³ /Rev. (0.25 L/Rev.)
Rated hydraulic flow	19.8 gpm (75 L/min)

ATTACHMENTS**SCARIFIER**

Type	Front mounted
Width of cut	46 in (1 168 mm)
Teeth	5
Optional	11
Tooth spacing	9.0 in (229 mm)
Optional	4.5 in (114 mm)
Lift above ground	20.75 in (527 mm)
Max. penetration	12.5 in (318 mm)
Weight	1,256 lb (570 kg)
	Includes front attachment group

PUSH BLOCK

Type	Front mounted
Weight	1,084 lb (492 kg)

REAR RIPPER

Type	Parallel
Ripper teeth	3
Optional	5
Scarifier teeth	5
Optional	9
Width of cut	86.4 in (2 195 mm)
Lift above ground:	
Ripper teeth	20.38 in (518 mm)
Scarifier teeth	27.67 in (703 mm)
Max. penetration:	
Ripper teeth	17.22 in (437 mm)
Scarifier teeth	9.43 in (252 mm)
Weight	2,167 lb (985 kg)

DOZER BLADE

Type	Front mounted
Width	109 in (2 762 mm)
Height	37.5 in (953 mm)
Lift above ground	24.5 in (622 mm)
Penetration	6.5 in (165 mm)
Weight	2,568 lb (1 165 kg)
	Includes front attachment group

COUNTERWEIGHT

Type	Front mounted
Weight	1,084 lb (492 kg)

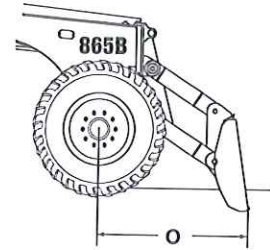
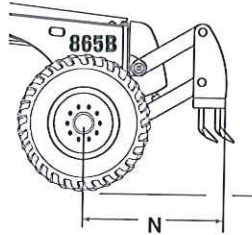
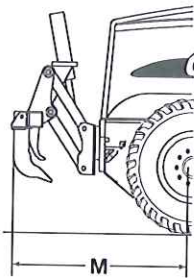
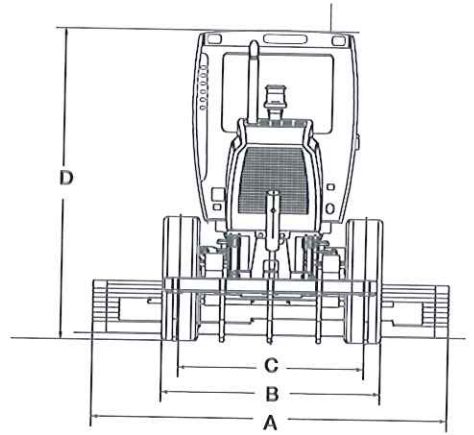
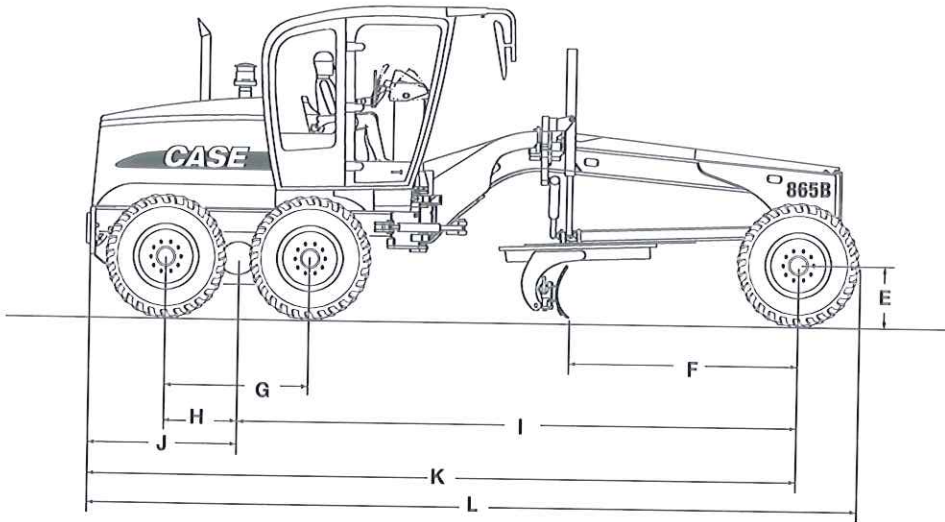

Line drawings are for illustrative purpose only and may not be exact representation of unit.

DIMENSIONS

	865B VHP
A. Blade width	14 ft 0 in (3 962 mm)
B. Distance between outside edges of tires	8 ft 2 in (2 452 mm)
C. Wheel tread – rim 9 x 24 - one piece rim	6 ft 11 in (2 106 mm)
D. Height to top of cab – high profile	10 ft 11 in (3 340 mm)
D. Height to top of cab – low profile	10 ft 4 in (3 150 mm)
E. Tire radius – when static	2 ft 0 in (610 mm)
F. Blade base	8 ft 5 in (2 562 mm)
G. Distance between tandem axles	5 ft 2 in (1 594 mm)
H. Distance between tandem center and wheel	2 ft 7 in (797 mm)
I. Wheelbase	20 ft 5 in (6 219 mm)
J. Distance between tandem center and rear end of machine	5 ft 5 in (1 650 mm)
K. Distance between front axle and rear end of machine	25 ft 10 in (7 869 mm)
L. Overall length – without ripper or front attachment	28 ft 0 in (8 534 mm)
M. Distance between rear tires and rear ripper	6 ft 8 in (2 028 mm)
N. Distance between front tires and front scarifier	5 ft 0 in (1 520 mm)
O. Distance between front tires and front dozer blade	5 ft 4 in (1 626 mm)
Outside tire turning radius	23 ft 9 in (7 250 mm)
Ground clearance – rear axle	14.9 in (380 mm)
Ground clearance – front axle	24.5 in (622 mm)

NOTE: All units equipped with 14.0 x 24-10 PR tires, ROPS cab with heater and A/C, std. battery, full fuel, 175 lb (79 kg) operator. Specifications per ISO 7134.

STANDARD EQUIPMENT

OPERATOR ENVIRONMENT

See page 1

ENGINE

FPT F4HE9687C turbocharged diesel

Tier 3 certified

Temperature controlled cooling fan

Charge air cooler

Air intake grid heater

Common rail electronic fuel injection

Hydraulic driven cooling fan

Auto idle

DRIVETRAIN

Hydraulic differential lock

HYDRAULICS

Closed center, load sensing hydraulic system

Controls for all functions

9 section control valve

Hydraulic moldboard side shift and pitch

5-position saddle

14 ft x 23.6 in (4267 x 600 mm) moldboard

8 hydraulic diagnostic quick couplers

TIRES

14.0 x 24-12 PR

INSTRUMENTS

Analog displays/Gauges:

Fuel level; Engine coolant temperature;

Transmission oil temperature;

Hydraulic oil temperature.

Monitor Functions:

Hour meter; Engine speed; Travel speed;

Current gear selection; FNR indication;

Clock; Trip computer; Fuel consumption;

Fuel level percentage; Oil pressure;

Coolant temperature; Engine oil

temperature; Transmission oil

temperature; Hydraulic oil temperature;

Turbocharger air temperature; Differential

lock indicator; Gear selection indicator;

Engine diagnostics; Transmission

diagnostics; System voltage; Error reporting;

Warning prompts; Indicator warning lamps –

main warning, parking brake, low brake

pressure, high beams, turn signals,

hazard lights, low fuel.

ELECTRICAL

(2) Heavy-duty batteries – 1010 CCA

Electronic Systems Monitor

Horn

Alternator – 90 amp

Backup alarm

Headlights

(2) Turn signals front

(2) Tail lights with turn signals, brake lights

Flood lights – cab mounted

TELEMATICS

CASE SiteWatch™ Telematics – includes hardware and a 3-yr Advanced data subscription

OPTIONAL EQUIPMENT

MOLDBOARDS

12 ft x 22 in (3658 x 559 mm), involute curve

13 ft x 23.6 in (4267 x 600 mm), involute curve

Extensions – 2 ft (610 mm)

Front Float Control

Moldboard Float Control

Lift cylinder/side shift accumulators

Lift cylinder accumulators

OPERATOR ENVIRONMENT

High profile ROPS/FOPS cab

Front windows openable with rear window defroster

Lower front wiper/washers

Rear windshield washer

Air suspension seat

Radio, AM/FM with CD player

Sunshade

TIRES

13.0 x 24-12 PR

14.0 x 24-10 PR

14.0 x 24-12 PR

14.0 x R24 XGLA

14.0 x R24 Snoplus

16.0 x 24-12 PR

17.5 x 25-12 PR

17.5 x 25-16 PR

17.5 x R25 XTLA

17.5 x R25 Snoplus

ELECTRICAL

(2) Front mounted working lights

(2) Floodlights at moldboard

(2) Floodlights at articulation

Snow wing lighting package

OTHER

Bidirectional engine cooling fan

Cold weather package

Fire extinguisher

Strobe light

Tool box – without tools

Deluxe tool box – with tools

Tire inflator kit

Spare wheel

Spare wheel support

Slow moving vehicle sign

Rear pull hook

ATTACHMENTS

Front pull hook

Front counterweight

Front dozer blade

Front scarifier

Front push plate

Front support and lift cylinder

Rear ripper



NOTE: All specifications are stated in accordance with SAE Standards or Recommended Practices, where applicable.

NOTE: All engines are compliant with current EPA emissions requirements.

IMPORTANT: Case Construction Equipment Inc. reserves the right to change these specifications without notice and without incurring any obligation relating to such change. Case Construction Equipment Inc. does not warrant the safety or reliability of attachments from other manufacturers.

CASE is a trademark registered in the United States and many other countries, owned by or licensed to CNH Industrial N.V., its subsidiaries or affiliates. CNH Industrial Capital is a trademark in the United States and many other countries, owned by or licensed to CNH Industrial N.V., its subsidiaries or affiliates.

Form No. CCE201503865B

Replaces form no. CCE201406865B

Printed in U.S.A.

865B VHP • Page 4 of 4

© 2015 CNH Industrial America LLC

All Rights Reserved



All Case construction equipment is biodiesel ready.



ENGINE - VHP

Model	FPT F4HE9687C, Tier 3 certified Compliant w/ EPA regulations effective January 2011 Electronic control
Type	4-stroke, turbocharged and air to air cooled
Cylinders	6, in-line
Bore/Stroke	4.09 in x 5.17 in (104 mm x 132 mm)
Displacement	409 in ³ (6.7 L)
Fuel injection	Common rail
Fuel	Diesel
Cooling	Liquid
Horsepower @ 2200 RPM – SAE J1995:	
Gross	193/205/220 hp (144/153/164 kW)
Net	178/190/205 hp (133/142/153 kW)
Maximum torque @ 1500 RPM:	
	612/649/686 ft-lb (830/880/930 N-m)

DRIVETRAIN

Rear axle	Graziano, planetary
Differential	Hydraulic lock, operator controlled
Inboard brakes	Wet disc
Number of discs/brake	5
Brake surface area	2,225 in ² (14 336 cm ²)
Tandems:	
Type	Welded plate
Oscillation	20° each way
Front axle	High strength, welded steel
Oscillation	15.3° each direction
Wheel lean	20° left/right
Tires – standard	14.0 x 24 12PR TL G2 Firestone
Rims	1-piece 9 in x 24 in (227 mm x 610 mm)
Transmission type:	
	Direct drive countershaft powershift w/ electronic shift control and inching pedal
Pump flow @ 2200 RPM	29.5 gpm (112 L/min)
Sump	Integral
Speeds	8 forward/4 reverse
Shifting	Single lever, bump style automatic electronic control
Diagnostics	On-board

DRIVETRAIN (cont.)

Speeds:	
Forward:	mph (km/h)
1st	2.7 (4.3)
2nd	3.7 (6.0)
3rd	5.2 (8.4)
4th	7.3 (11.8)
5th	10.4 (16.7)
6th	14.4 (23.1)
7th	20.2 (32.5)
8th	27.8 (44.8)
Reverse:	mph (km/h)
1st	2.5 (4.0)
2nd	5.0 (8.0)
3rd	9.8 (15.8)
4th	19.3 (31.0)

ELECTRICAL

Voltage	24 Volts, negative ground
Alternator	90 amp
Batteries	(2) Low-maintenance 1010 CCA – 100 Ah (20 hr rate)
Work lights:	
	Headlights (2); Turn signals, front/rear; Stop/tail (2); Rear mounted floods (2); Front mounted floods (2).
Backup alarm	Standard

OPERATOR ENVIRONMENT

ROPS/FOPS cab – SAE J231, ISO 3449;
Adjustable operator's console; Adjustable cloth
suspension seat w/ 3 in (76 mm) retractable
seat belt; Safety glass; Dome light; Inside
rearview mirror; Outside rearview mirrors; Cup
holder; Storage tray; 12-volt outlet; Radio ready
– 12 Volt; Electrical master switch – automatic;
Heater/defroster/pressurizer; Air conditioner;
Sound suppression; Cab doors – left/right;
Steps – left/right; Steering wheel;
Windshield wiper – front; Windshield
washer – front; Sunshade.

OPERATING WEIGHT

W/ 14 ft (4.27 m) moldboard, 17.5-25 tires, front counterweight, 175 lb (79 kg) operator and full fuel:	35,273 lb (16 000 kg)
Weight, front axle	11,133 lb (5050 kg)
Weight, rear axle	24,140 lb (10 950 kg)
Blade pressure	20,976 lb (9514 kg)

HYDRAULICS

System design	Closed center, load sensing
Hydraulic pump	Load sensing piston pump, variable displacement, pressure and flow compensated
Rated flow @ 2200 RPM	49 gpm (187 L/min)
Control valve	9 section
Side shift and pitch	Hydraulic
Saddle	5 positions
Diagnostic quick couplers	8

SERVICE CAPACITIES

Engine	4.4 gal (17.5 L)
w/ filter change	4.7 gal (18.5 L)
Fuel	90 gal (341 L)
Transmission	5.0 gal (23 L)
w/ filter change	6.6 gal (25 L)
Radiator	10.5 gal (40 L)
Hydraulic reservoir	24 gal (90 L)
Hydraulic system	50.2 gal (190 L)
Circle gearbox	0.75 gal (2.8 L)
Rear axle center	11.6 gal (44 L)
Total axle	11.6 gal (44 L)
Tandem case, each	18.4 gal (69 L)

OTHER SPECIFICATIONS

Steering:	
Type	Hydrostatic power steering
Turns – lock-to-lock	4.75
Pump capacity @ 2200 engine RPM:	
	11.1 gpm (41.8 L/min)
Relief pressure	2200 psi (151 bar) Integral w/ priority valve
Cylinder (2):	2.0 in bore x 11.85 in stroke x 1.0 in rod dia. (50.8 mm x 301.0 mm x 25.4 mm)
Supplemental steering	Integral
Articulation:	
Type	Hydraulic actuated – w/ lock valve
Range	25° left/right
Controls	Hydraulic

MAINFRAME

Type	All welded box
Front section:	
Size	10.0 in x 11.73 in (254 mm x 298 mm)
Weight – each side	124.7 lb-ft (172.8 kg/m)
Rear section:	
Size	4.75 in x 11.75 in (121 mm x 299 mm)
Weight – each side	55.6 lb-ft (84.0 kg/m)

DRAWBAR

Type:	"A" frame welded construction with center mounted circle turn motor
Ball and circle	Shim adjustable

MOLDBOARD

Type	High-carbon steel
Shape	Involute curve
Length	14 ft 0 in (4 267 mm)
Height	23.6 in (600 mm)
Thickness	0.875 in (22 mm)
End bits	2, interchangeable
Blade pitch positions:	
Normal pitch	47°
Minimum pitch	42°
Maximum pitch	87°
Blade shift:	
Right	27.0 in (686 mm)
Left	21.0 in (533 mm)
Max. bank cutting angle:	
Right	90°
Left	90°
Max. ground penetration	28 in (711.2 mm)
Max. lift above ground	17.5 in (444.5 mm)

CIRCLE

Type	Welded construction
Diameter:	
Max. outside	69.0 in (1 752 mm)
Vertical member	63.0 in (1 600 mm)
Rotation	360°
Speed	1.2 rpm (7.2°/second)
Drive	Hydraulic motor
Type	Roller geroter
Displacement	15.26 in ³ /Rev (0.25 L/Rev)
Rated hydraulic flow	19.8 gpm (75 L/min)

ATTACHMENTS**SCARIFIER**

Type	Front mounted
Width of cut	46 in (1 168 mm)
Teeth	5
Optional	11
Tooth spacing	9.0 in (229 mm)
Optional	4.5 in (114 mm)
Lift above ground	20.75 in (527 mm)
Max. penetration	12.5 in (318 mm)
Weight	1,256 lb (570 kg)
	Includes front attachment group

PUSH BLOCK

Type	Front mounted
Weight	1,084 lb (492 kg)

REAR RIPPER

Type	Parallel
Ripper teeth	3
Optional	5
Scarifier teeth	5
Optional	9
Width of cut	92.13 in (2 340 mm)
Lift above ground:	
Ripper teeth	20.38 in (518 mm)
Scarifier teeth	27.67 in (703 mm)
Max. penetration:	
Ripper teeth	17.22 in (437 mm)
Scarifier teeth	9.43 in (252 mm)
Weight	1,874 lb (850 kg)

DOZER BLADE

Type	Front mounted
Width	109 in (2 762 mm)
Height	37.5 in (953 mm)
Lift above ground	24.5 in (622 mm)
Penetration	6.5 in (165 mm)
Weight	2,568 lb (1 165 kg)
	Includes front attachment group

COUNTERWEIGHT

Type	Front mounted
Weight	1,084 lb (492 kg)

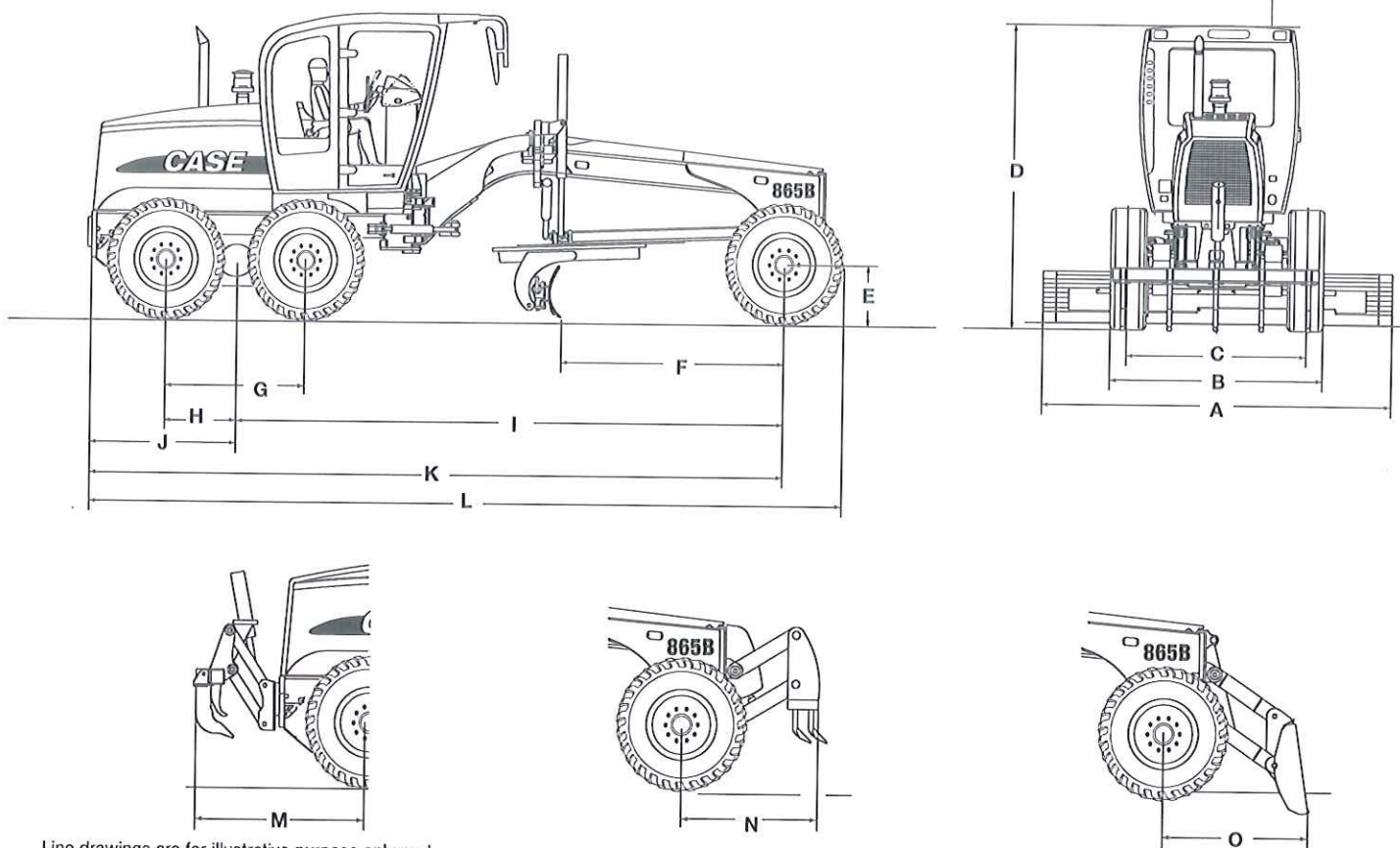

Line drawings are for illustrative purpose only and may not be exact representation of unit.

DIMENSIONS

	865B AWD VHP
A. Blade width	14 ft 0 in (3 962 mm)
B. Distance between outside edges of tires	8 ft 2 in (2 452 mm)
C. Wheel tread – rim 9 x 24 - one piece rim	6 ft 10 in (2 106 mm)
D. Height to top of cab – high profile	10 ft 11 in (3 340 mm)
D. Height to top of cab – low profile	10 ft 4 in (3 150 mm)
E. Tire radius – when static	2 ft 0 in (610 mm)
F. Blade base	8 ft 5 in (2 562 mm)
G. Distance between tandem axles	5 ft 2 in (1 594 mm)
H. Distance between tandem center and wheel	2 ft 7 in (797 mm)
I. Wheelbase	20 ft 5 in (6 219 mm)
J. Distance between tandem center and rear end of machine	5 ft 5 in (1 650 mm)
K. Distance between front axle and rear end of machine	25 ft 10 in (7 869 mm)
L. Overall length – without ripper or front attachment	28 ft 0 in (8 534 mm)
M. Distance between rear tires and rear ripper	6 ft 8 in (2 028 mm)
N. Distance between front tires and front scarifier	5 ft 0 in (1 520 mm)
O. Distance between front tires and front dozer blade	5 ft 4 in (1 626 mm)
Outside tire turning radius	23 ft 9 in (7 250 mm)
Ground clearance – rear axle	14.9 in (380 mm)
Ground clearance – front axle	24.5 in (622 mm)

NOTE: All units equipped with 14.0 x 24-10 PR tires, ROPS cab with heater and A/C, std. battery, full fuel, 175 lb (79 kg) operator. Specifications per ISO 7134.

STANDARD EQUIPMENT

OPERATOR ENVIRONMENT

See page 1

ENGINE

FPT F4HE9687C turbocharged diesel
Tier 3 certified
Temperature controlled cooling fan
Charge air cooler
Air intake grid heater
Common rail electronic fuel injection
Hydraulic driven cooling fan
Auto idle

DRIVETRAIN

Hydraulic differential lock

HYDRAULICS

Closed center, load sensing hydraulic system
Controls for all functions
9 section control valve
Hydraulic moldboard side shift and pitch
5-position saddle
14 ft x 23.6 in (4267 x 600 mm) moldboard
Moldboard Float Control
8 hydraulic diagnostic quick couplers

TIRES

14.0 x 24-12 PR

INSTRUMENTS

Analog displays/Gauges:
Fuel level; Engine coolant temperature;
Transmission oil temperature;
Hydraulic oil temperature.
Monitor Functions:
Hour meter; Engine speed; Travel speed;
Current gear selection; FNR indication;
Clock; Trip computer; Fuel consumption;
Fuel level percentage; Oil pressure;
Coolant temperature; Engine oil
temperature; Transmission oil temperature;
Hydraulic oil temperature; Turbocharger air
temperature; Differential lock indicator;
Engine diagnostics; Transmission
diagnostics; System voltage; Error reporting;
Warning prompts; Indicator warning lamps –
main warning, parking brake, low brake
pressure, high beams, turn signals,
hazard lights, low fuel.

ELECTRICAL

(2) Heavy-duty batteries – 1010 CCA
Electronic Systems Monitor
Horn
Alternator – 90 amp
Backup alarm
Headlights
(2) Turn signals front
(2) Tail lights with turn signals, brake lights
Flood lights – cab mounted

TELEMATICS

CASE SiteWatch™ Telematics – includes
hardware and a 3-yr Advanced
data subscription

OPTIONAL EQUIPMENT

MOLDBOARDS

12 ft x 22 in (3658 x 559 mm), involute curve
13 ft x 23.6 in (4267 x 600 mm), involute curve
Extensions – 2 ft (610 mm)
Front Float Control
Lift cylinder/side shift accumulators
Lift cylinder accumulators

OPERATOR ENVIRONMENT

High profile ROPS/FOPS cab
Front windows openable with rear
window defroster
Lower front wiper/washers
Rear windshield washer
Air suspension seat
Radio, AM/FM with CD player

TIRES

13.0 x 24-12 PR
14.0 x 24-10 PR
14.0 x 24-12 PR
14.0 x R24 XGLA radial
14.0 x R24 Snoplus
16.0 x 24-12 PR
17.5 x 25-12 PR
17.5 x 25-16 PR
17.5 x R25 XTLA radial
17.5 x R25 Snoplus

ELECTRICAL

(2) Front mounted working lights
(2) Floodlights at moldboard
(2) Floodlights at articulation
Snow plow lighting package

OTHER

Bidirectional engine cooling fan
Cold weather package
Fire extinguisher
Strobe light
Tool box – without tools
Deluxe tool box – with tools
Tire inflator kit
Spare wheel
Spare wheel support
Slow moving vehicle sign
Rear pull hook

ATTACHMENTS

Front pull hook
Front counterweight
Front dozer blade
Front scarifier
Front push plate
Front support and lift cylinder
Rear ripper



NOTE: All specifications are stated in accordance with SAE Standards or Recommended Practices, where applicable.

NOTE: All engines are compliant with current EPA emissions requirements.

IMPORTANT: Case Construction Equipment Inc. reserves the right to change these specifications without notice and without incurring any obligation relating to such change. Case Construction Equipment Inc. does not warrant the safety or reliability of attachments from other manufacturers.

CASE is a trademark registered in the United States and many other countries, owned by or licensed to CNH Industrial N.V., its subsidiaries or affiliates. CNH Industrial Capital is a trademark in the United States and many other countries, owned by or licensed to CNH Industrial N.V., its subsidiaries or affiliates.

Form No. CCE201503865BAWD
Replaces form no. CCE201406865BAWD

Printed in U.S.A.
865B AWD VHP • Page 4 of 4

© 2015 CNH Industrial America LLC
All Rights Reserved



All Case construction equipment is biodiesel ready.



www.casece.com

ENGINE

Model	FPT F4HE9684L, Tier 3 certified Compliant w/ EPA regulations effective January 2011 Electronic control
Type	4-stroke, turbocharged and air to air after cooled
Cylinders	6, in-line
Bore/Stroke	4.09 in x 5.17 in (104 mm x 132 mm)
Displacement	409 in ³ (6.7 L)
Fuel injection	Common rail
Fuel	Diesel
Cooling	Liquid
Horsepower @ 2200 RPM – SAE J1995:	
Gross	220/234 hp (164/175 kW)
Net	205/219 hp (153/163 kW)
Maximum torque @ 1600 RPM:	
	682/726 ft-lb (924/984 N-m)

DRIVETRAIN

Rear axle	Graziano, planetary
Differential	Hydraulic lock, operator controlled
Outboard brakes	Wet disc
Number of discs/brake	6
Brake surface area	2,686 in ² (17 191 cm ²)
Tandems:	
Type	Welded plate
Oscillation	20° each way
Front axle	High strength, welded steel
Oscillation	15.3° each direction
Wheel lean	20° left/right
Tires	14.0 x 24 12PR TL G2 Firestone
Rims	1-piece 9 in x 24 in (227 mm x 610 mm)
Transmission type:	
	Direct drive countershaft powershift w/ electronic shift control and inching pedal
Pump flow @ 2200 RPM	29.5 gpm (112 L/min)
Sump	Integral
Speeds	n/a
Shifting	Single lever, bump style automatic electronic control
Diagnostics	On-board

DRIVETRAIN (cont.)

Speeds:	
Forward:	mph (km/h)
1st	2.7 (4.3)
2nd	3.7 (6.0)
3rd	5.2 (8.4)
4th	7.3 (11.8)
5th	10.4 (16.7)
6th	14.4 (23.1)
7th	20.2 (32.5)
8th	27.8 (44.8)
Reverse:	mph (km/h)
1st	2.5 (4.0)
2nd	5.0 (8.0)
3rd	9.8 (15.8)
4th	19.3 (31.0)

ELECTRICAL

Voltage	24 Volts, negative ground
Alternator	90 amp
Batteries	(2) Low-maintenance 1010 CCA – 100 Ah (20 hr rate)
Work lights:	
	Headlights (2); Turn signals, front/rear; Stop/tail (2); Rear mounted floods (2); Front mounted floods (2).
Backup alarm	Standard

OPERATOR ENVIRONMENT

ROPS/FOPS cab – SAE J231, ISO 3449;
Adjustable operator's console; Adjustable cloth
suspension seat w/ 3 in (76 mm) retractable
seat belt; Safety glass; Dome light; Inside
rearview mirror; Outside rearview mirrors; Cup
holder; Storage tray; 12-volt outlet; Radio ready
– 12 Volt; Electrical master switch – automatic;
Heater/defroster/pressurizer, Air conditioner;
Sound suppression; Cab doors – left/right;
Steps – left/right; Steering wheel;
Windshield wiper – front; Windshield
washer – front.

OPERATING WEIGHT

W/ 14 ft (4.27 m) moldboard, 20.5-25 tires, front counterweight, 175 lb (79 kg) operator and full fuel:	39,771 lb (18 040 kg)
Weight, front axle	12,301 lb (5 580 kg)
Weight, rear axle	27,469 lb (12 460 kg)
Blade pressure	21,178 lb (9 606 kg)

HYDRAULICS

System design	Closed center, load sensing
Hydraulic pump	Load sensing piston pump, variable displacement, pressure and flow compensated
Rated flow @ 2200 RPM	49 gpm (187 L/min)
Control valve	9 section
Side shift and pitch	Hydraulic
Saddle	5 positions
Diagnostic quick couplers	8

SERVICE CAPACITIES

Engine	4.4 gal (17.5 L)
w/ filter change	4.7 gal (18.5 L)
Fuel	90 gal (341 L)
Transmission	5.8 gal (22 L)
w/ filter change	7.5 gal (28 L)
Radiator	10.5 gal (40 L)
Hydraulic reservoir	25 gal (94.6 L)
Hydraulic system	47.5 gal (180 L)
Circle gearbox	3 qt (2.8 L)
Rear axle center	10.5 gal (40 L)
Total axle	10.5 gal (40 L)
Tandem case, each	15.9 gal (60 L)

OTHER SPECIFICATIONS

Steering:	
Type	Hydrostatic power steering
Turns – lock-to-lock	4.75
Pump capacity @ 2200 engine RPM:	
	13.8 gpm (52.25 L/min)
Relief pressure	2200 psi (151 bar) Integral w/ priority valve
Cylinder (2):	
	2.0 in bore x 11.85 in stroke x 1.0 in rod dia. (50.8 mm x 301.0 mm x 25.4 mm)
Supplemental steering	Integral*
Articulation:	
Type	Hydraulic actuated – w/ lock valve
Range	25° left/right
Controls	Hydraulic

*NOTE: Not applicable when equipped w/ 20.5 x 25 tires

MAINFRAME

Type	All welded box
Front section:	
Size	10.0 in x 11.73 in (254 x 298 mm)
Weight – each side	124.7 lb-ft (172.8 kg/m)
Rear section:	
Size	4.75 in x 11.75 in (121 x 299 mm)
Weight – each side	76.8 lb-ft (114.2 kg/m)

DRAWBAR

Type:	"A" frame welded construction with center mounted circle turn motor
Ball and circle	Shim adjustable

MOLDBOARD

Type	High-carbon steel
Shape	Involute curve
Length	14 ft 0 in (4 267 mm)
Height	23.6 in (600 mm)
Thickness	0.875 in (22.2 mm)
End bits	2, interchangeable
Blade pitch positions:	
Normal pitch	47°
Minimum pitch	42°
Maximum pitch	87°
Blade shift:	
Right	27.0 in (686 mm)
Left	21.0 in (533 mm)
Max. bank cutting angle:	
Right	90°
Left	90°
Max. ground penetration	28 in (711.2 mm)
Max. lift above ground	17.5 in (444.5 mm)

CIRCLE

Type	Welded construction
Diameter:	
Max. outside	69.0 in (1 752.6 mm)
Vertical member	63.0 in (1 600.2 mm)
Rotation	360°
Speed	1.1 RPM (6.8°/second)
Drive	Hydraulic motor
Type	Roller geroter
Displacement	15.26 in ³ /Rev. (0.25 L/Rev.)
Rated hydraulic flow	19.8 gpm (75 L/min)

ATTACHMENTS**SCARIFIER**

Type	Front mounted
Width of cut	46 in (1 168 mm)
Teeth	5
Optional	11
Tooth spacing	9.0 in (229 mm)
Optional	4.5 in (114 mm)
Lift above ground	20.75 in (527 mm)
Max. penetration	12.5 in (318 mm)
Weight	1,256 lb (570 kg)
	Includes front attachment group

PUSH BLOCK

Type	Front mounted
Weight	1,084 lb (492 kg)

REAR RIPPER

Type	Parallel
Ripper teeth	3
Optional	5
Scarifier teeth	5
Optional	9
Width of cut	86.4 in (2 195 mm)
Lift above ground:	
Ripper teeth	20.38 in (518 mm)
Scarifier teeth	27.67 in (703 mm)
Max. penetration:	
Ripper teeth	17.22 in (437 mm)
Scarifier teeth	9.43 in (252 mm)
Weight	2,167 lb (985 kg)

DOZER BLADE

Type	Front mounted
Width	109 in (2 762 mm)
Height	37.5 in (953 mm)
Lift above ground	24.5 in (622 mm)
Penetration	6.5 in (165 mm)
Weight	2,568 lb (1 165 kg)
	Includes front attachment group

COUNTERWEIGHT

Type	Front mounted
Weight	1,084 lb (492 kg)

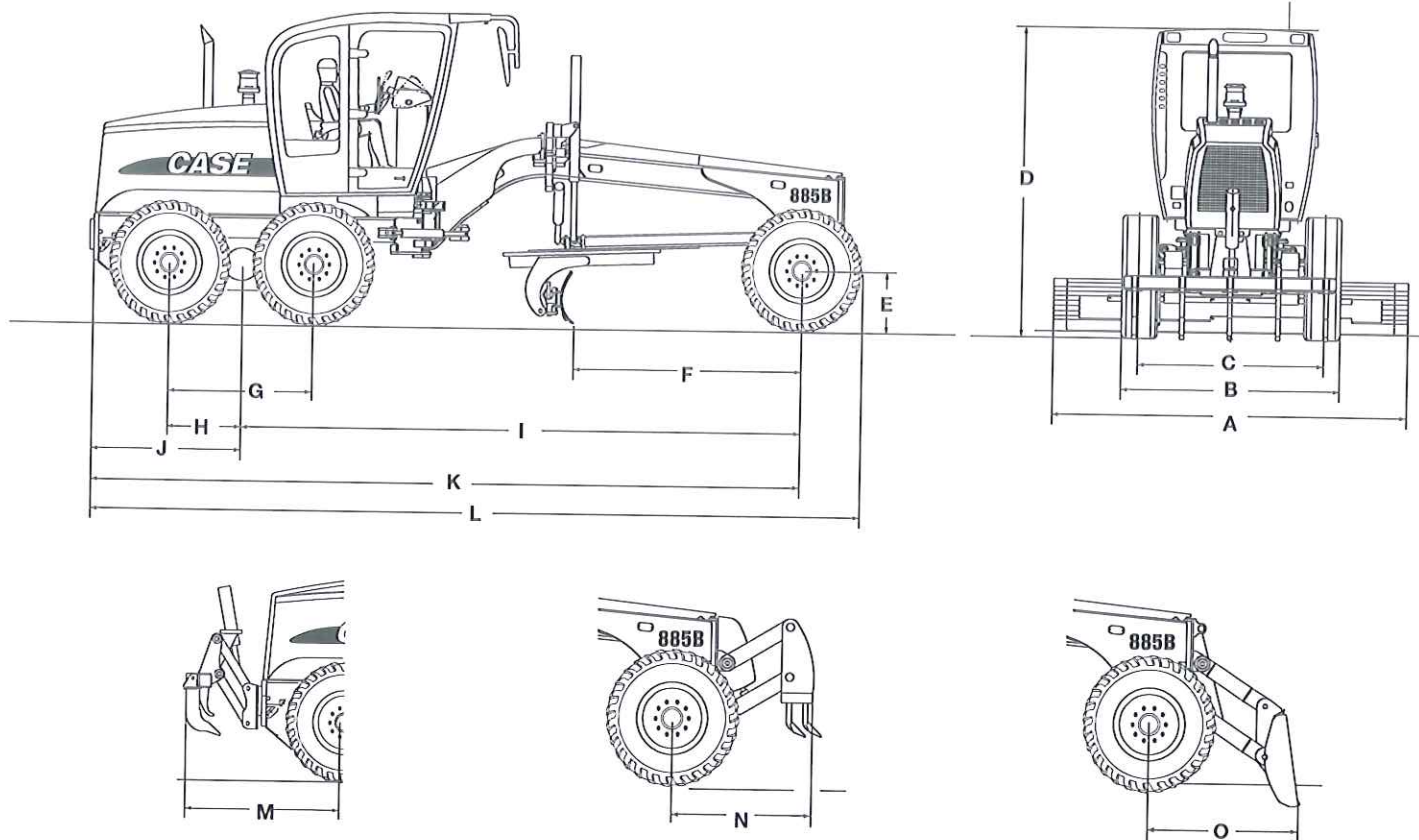

Line drawings are for illustrative purpose only and may not be exact representation of unit.

DIMENSIONS

	885B DHP
A. Blade width	14 ft 0 in (4 267 mm)
B. Distance between outside edges of tires	8 ft 8 in (2 650 mm)
C. Wheel tread	7 ft 2 in (2 174 mm)
D. Height to top of cab	10 ft 11 in (3 340 mm)
D. Height to top of cab – low profile	10 ft 4 in (3 150 mm)
E. Tire radius – when static	2 ft 0 in (610 mm)
F. Blade base	8 ft 5 in (2 562 mm)
G. Distance between tandem axles	5 ft 4 in (1 624 mm)
H. Distance between tandem center and wheel	2 ft 8 in (812 mm)
I. Wheelbase	20 ft 5 in (6 219 mm)
J. Distance between tandem center and rear end of machine	5 ft 5 in (1 650 mm)
K. Distance between front axle and rear end of machine	25 ft 10 in (7 874 mm)
L. Overall length – without ripper or front attachment	28 ft 0 in (8 534 mm)
M. Distance between rear tires and rear ripper	6 ft 8 in (2 040 mm)
N. Distance between front tires and front scarifier	5 ft 0 in (1 524 mm)
O. Distance between front tires and front dozer blade	5 ft 5 in (1 645 mm)
Outside tire turning radius	23 ft 11 in (7 289 mm)
Ground clearance – rear axle	14.9 in (380 mm)
Ground clearance – front axle	24.5 in (622 mm)

NOTE: All units equipped with 14.0 x 24-10 PR tires, ROPS cab with heater and A/C, std. battery, full fuel, 175 lb (79 kg) operator. Specifications per ISO 7134.

STANDARD EQUIPMENT

OPERATOR ENVIRONMENT

See page 1

ENGINE

FPT F4HE9684L turbocharged diesel
Tier 3 certified
Temperature controlled cooling fan
Charge air cooler
Air intake grid heater
Common rail electronic fuel injection
Hydraulic driven cooling fan
Auto idle

DRIVETRAIN

Hydraulic differential lock

HYDRAULICS

Closed center, load sensing hydraulic system
Controls for all functions
9 section control valve
Hydraulic moldboard side shift and pitch
5-position saddle
14 ft x 23.6 in (4267 x 600 mm) moldboard
8 hydraulic diagnostic quick couplers

TIRES

14.0 x 24-12 PR

INSTRUMENTS

Analog displays/Gauges:

Fuel level; Engine coolant temperature;
Transmission oil temperature;
Hydraulic oil temperature.

Monitor Functions:

Hour meter; Engine speed; Travel speed;
Current gear selection; FNR indication;
Clock; Trip computer; Fuel consumption;
Fuel level percentage; Oil pressure;
Coolant temperature; Engine oil
temperature; Transmission oil temperature;
Hydraulic oil temperature; Turbocharger air
temperature; Differential lock indicator;
Gear selection indicator; Engine diagnostics;
Transmission diagnostics; System voltage;
Error reporting; Warning prompts; Indicator
warning lamps – main warning, parking
brake, low brake pressure, high beams, turn
signals, hazard lights, low fuel.

ELECTRICAL

(2) Heavy-duty batteries – 1010 CCA
Electronic Systems Monitor
Horn
Alternator – 90 amp
Backup alarm
Headlights
(2) Turn signals front
(2) Tail lights with turn signals, brake lights
Flood lights – cab mounted

TELEMATICS

CASE SiteWatch™ Telematics – includes
hardware and a 3-yr Advanced
data subscription

OPTIONAL EQUIPMENT

MOLDBOARDS

12 ft x 22 in (3658 x 559 mm), involute curve
13 ft x 23.6 in (3962 x 600 mm), involute curve
Extensions – 2 ft (610 mm)
Front Float Control
Moldboard Float Control
Lift cylinder/side shift accumulator
Lift cylinder accumulator

OPERATOR STATION

High profile ROPS/FOPS cab
Front windows openable with rear
window defroster
Lower front wiper/washers
Rear windshield washer
Air suspension seat
Radio, AM/FM with CD player
Sunshade

TIRES

14.0 x 24-12 PR
14.0 x R24 XGLA
14.0 x R24 Snoplus
16.0 x 24-12 PR
17.5 x 25-12 PR
17.5 x 25-16 PR
17.5 x R25 XTLA
17.5 x R25 Snoplus
20.5 x 25-12 PR

ELECTRICAL

(2) Front mounted working lights
(2) Floodlights at moldboard
(2) Floodlights at articulation
Snow wing lighting package

OTHER

Bidirectional engine cooling fan
Cold weather package
Fire extinguisher
Strobe light
Tool box – without tools
Deluxe tool box – with tools
Tire inflator kit
Spare wheel
Spare wheel support
Slow moving vehicle sign
Rear pull hook

ATTACHMENTS

Front pull hook
Front counterweight
Front dozer blade
Front scarifier
Front push plate
Front support and lift cylinder
Rear ripper



NOTE: All specifications are stated in accordance with SAE Standards or Recommended Practices, where applicable.

NOTE: All engines are compliant with current EPA emissions requirements.

IMPORTANT: Case Construction Equipment Inc. reserves the right to change these specifications without notice and without incurring any obligation relating to such change. Case Construction Equipment Inc. does not warrant the safety or reliability of attachments from other manufacturers.

CASE is a trademark registered in the United States and many other countries, owned by or licensed to CNH Industrial N.V., its subsidiaries or affiliates. CNH Industrial Capital is a trademark in the United States and many other countries, owned by or licensed to CNH Industrial N.V., its subsidiaries or affiliates.

Form No. CCE201503885B

Replaces form no. CCE201406885B

Printed in U.S.A.
885B DHP • Page 4 of 4



All Case construction equipment is biodiesel ready.



www.casece.com

© 2015 CNH Industrial America LLC
All Rights Reserved

ENGINE

Model	FPT F4HE9684L, Tier 3 certified Compliant w/ EPA regulations effective January 2011 Electronic control
Type	4-stroke, turbocharged and air to air after cooled
Cylinders	6, in-line
Bore/Stroke	4.09 in x 5.17 in (104 mm x 132 mm)
Displacement	409 in ³ (6.7 L)
Fuel injection	Common rail
Fuel	Diesel
Cooling	Liquid
Horsepower @ 2200 RPM – SAE J1995:	
Gross	220/234 hp (164/175 kW)
Net	205/219 hp (153/163 kW)
Maximum torque @ 1600 RPM:	
	682/726 ft-lb (924/984 N-m)

DRIVETRAIN

Rear axle	Graziano, planetary
Differential	Hydraulic lock, operator controlled
Outboard brakes	Wet disc
Number of discs/brake	6
Brake surface area	2,686 in ² (17 191 cm ²)
Tandems:	
Type	Welded plate
Oscillation	20° each way
Front axle	High strength, welded steel
Oscillation	15.3° each direction
Wheel lean	20° left/right
Tires	14.0 x 24 12PR TL G2 Firestone
Rims	1-piece 9 in x 24 in (227 mm x 610 mm)
Transmission type:	
	Direct drive countershaft powershift w/ electronic shift control and inching pedal
Pump flow @ 2200 RPM	29.5 gpm (112 L/min)
Sump	Integral
Speeds	8 forward/4 reverse
Shifting	Single lever, bump style automatic electronic control
Diagnostics	On-board

DRIVETRAIN (cont.)

Speeds:	
Forward:	mph (km/h)
1st	2.7 (4.3)
2nd	3.7 (6.0)
3rd	5.2 (8.4)
4th	7.3 (11.8)
5th	10.4 (16.7)
6th	14.4 (23.1)
7th	20.2 (32.5)
8th	27.8 (44.8)
Reverse:	mph (km/h)
1st	2.5 (4.0)
2nd	5.0 (8.0)
3rd	9.8 (15.8)
4th	19.3 (31.0)

ELECTRICAL

Voltage	24 Volts, negative ground
Alternator	90 amp
Batteries	(2) Low-maintenance 1010 CCA – 100 Ah (20 hr rate)
Work lights:	
	Headlights (2); Turn signals, front/rear; Stop/tail (2); Rear mounted floods (2); Front mounted floods (2).
Backup alarm	Standard

OPERATOR ENVIRONMENT

ROPS/FOPS cab – SAE J231, ISO 3449;
Adjustable operator's console; Adjustable cloth
suspension seat w/ 3 in (76 mm) retractable
seat belt; Safety glass; Dome light; Inside
rearview mirror; Outside rearview mirrors; Cup
holder; Storage tray; 12-volt outlet; Radio ready
– 12 Volt; Electrical master switch – automatic;
Heater/defroster/pressurizer; Air conditioner;
Sound suppression; Cab doors – left/right;
Steps – left/right; Steering wheel;
Windshield wiper – front; Windshield
washer – front; Sunshade.

OPERATING WEIGHT

W/ 14 ft (4.27 m) moldboard, 20.5-25 tires, front counterweight, 175 lb (79 kg) operator and full fuel:	41,248 lb (18 710 kg)
Weight, front axle	13,337 lb (6 050 kg)
Weight, rear axle	27,910 lb (12 660 kg)
Blade pressure	26,278 lb (11 919 kg)

HYDRAULICS

System design	Closed center, load sensing
Hydraulic pump	Load sensing piston pump, variable displacement, pressure and flow compensated
Rated flow @ 2200 RPM	49 gpm (186 L/min)
Control valve	9 section
Side shift and pitch	Hydraulic
Saddle	5 positions
Diagnostic quick couplers	8

SERVICE CAPACITIES

Engine	4.4 gal (17.5 L)
w/ filter change	4.7 gal (18.5 L)
Fuel	90 gal (341 L)
Transmission	5.8 gal (22 L)
w/ filter change	7.5 gal (28.5 L)
Radiator	10.5 gal (40 L)
Hydraulic reservoir	25 gal (94.6 L)
Hydraulic system	47.5 gal (180 L)
Circle gearbox	0.75 gal (2.8 L)
Rear axle center	10.5 gal (40 L)
Total axle	10.5 gal (40 L)
Tandem case, each	18.4 gal (69 L)

OTHER SPECIFICATIONS

Steering:	
Type	Hydrostatic power steering
Turns – lock-to-lock	4.75
Pump capacity @ 2200 engine RPM:	
	11.1 gpm (41.8 L/min)
Relief pressure	2200 psi (151 bar) Integral w/ priority valve
Cylinder (2):	
	2.0 in bore x 11.85 in stroke x 1.0 in rod dia. (50.8 mm x 301.0 mm x 25.4 mm)
Supplemental steering	Integral*
Articulation:	
Type	Hydraulic actuated – w/ lock valve
Range	25° left/right
Controls	Hydraulic

*NOTE: Not applicable when equipped w/ 20.5 x 25 tires

MAINFRAME

Type	All welded box
Front section:	
Size	10.0 in x 11.73 in (254 mm x 298 mm)
Weight – each side	124.7 lb-ft (172.8 kg/m)
Rear section:	
Size	4.75 in x 11.75 in (121 mm x 299 mm)
Weight – each side	76.8 lb-ft (114.2 kg/m)

DRAWBAR

Type:	"A" frame welded construction with center mounted circle turn motor
Ball and circle	Shim adjustable

MOLDBOARD

Type	High-carbon steel
Shape	Involute curve
Length	14 ft 0 in (4 267 mm)
Height	23.6 in (600 mm)
Thickness	0.875 in (22.2 mm)
End bits	2, interchangeable
Blade pitch positions:	
Normal pitch	47°
Minimum pitch	42°
Maximum pitch	87°
Blade shift:	
Right	27.0 in (686 mm)
Left	21.0 in (533 mm)
Max. bank cutting angle:	
Right	90°
Left	90°
Max. ground penetration	28 in (711.2 mm)
Max. lift above ground	17.5 in (444.5 mm)

CIRCLE

Type	Welded construction
Diameter:	
Max. outside	69.0 in (1 752.6 mm)
Vertical member	63.0 in (1 600.2 mm)
Rotation	360°
Speed	1.2 RPM (7.2°/second)
Drive	Hydraulic motor
Type	Roller geroter
Displacement	15.26 in ³ /Rev. (0.25 L/Rev.)
Rated hydraulic flow	19.8 gpm (75 L/min)

ATTACHMENTS**SCARIFIER**

Type	Front mounted
Width of cut	46 in (1 168 mm)
Teeth	5
Optional	11
Tooth spacing	9.0 in (229 mm)
Optional	4.5 in (114.3 mm)
Lift above ground	20.75 in (527 mm)
Max. penetration	12.5 in (318 mm)
Weight	1,256 lb (570 kg)
	Includes front attachment group

PUSH BLOCK

Type	Front mounted
Weight	1,084 lb (492 kg)

REAR RIPPER

Type	Parallel
Ripper teeth	3
Optional	5
Scarifier teeth	5
Optional	9
Width of cut	86.4 in (2 195 mm)
Lift above ground:	
Ripper teeth	20.38 in (518 mm)
Scarifier teeth	27.67 in (703 mm)
Max. penetration:	
Ripper teeth	17.22 in (437 mm)
Scarifier teeth	9.43 in (252 mm)
Weight	1,874 lb (850 kg)

DOZER BLADE

Type	Front mounted
Width	109 in (2 762 mm)
Height	37.5 in (953 mm)
Lift above ground	24.5 in (622 mm)
Penetration	6.5 in (165 mm)
Weight	2,568 lb (1 165 kg)
	Includes front attachment group

COUNTERWEIGHT

Type	Front mounted
Weight	1,084 lb (492 kg)

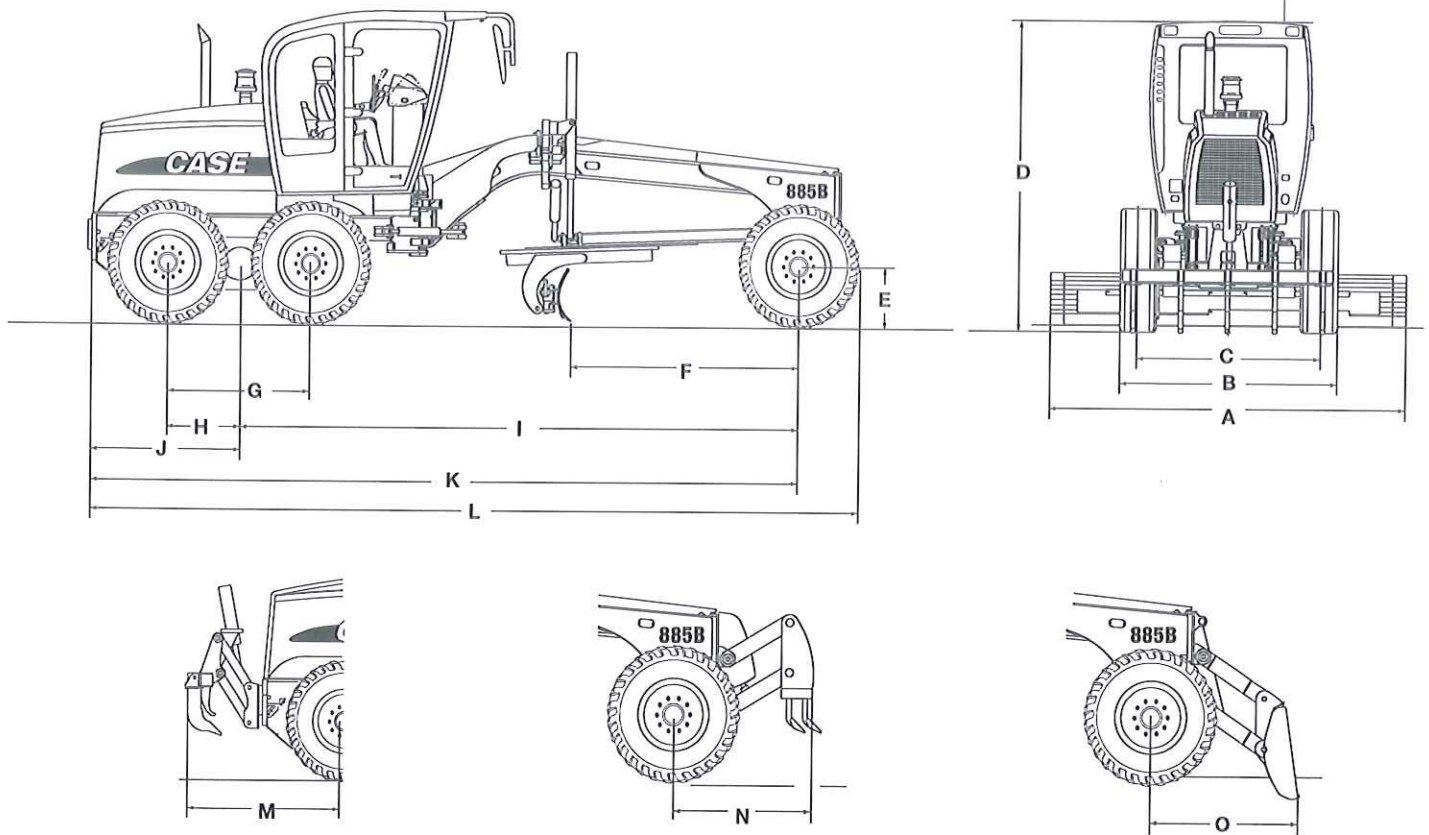

Line drawings are for illustrative purpose only and may not be exact representation of unit.

DIMENSIONS

	885B AWD
A. Blade width	14 ft 0 in (4 267 mm)
B. Distance between outside edges of tires	8 ft 8 in (2 650 mm)
C. Wheel tread	7 ft 1 in (2 174 mm)
D. Height to top of cab	10 ft 11 in (3 340 mm)
D. Height to top of cab – low profile	10 ft 4 in (3 150 mm)
E. Tire radius – when static	2 ft 0 in (610 mm)
F. Blade base	8 ft 5 in (2 562 mm)
G. Distance between tandem axles	5 ft 4 in (1 624 mm)
H. Distance between tandem center and wheel	2 ft 8 in (812 mm)
I. Wheelbase	20 ft 5 in (6 219 mm)
J. Distance between tandem center and rear end of machine	5 ft 5 in (1 650 mm)
K. Distance between front axle and rear end of machine	25 ft 10 in (7 874 mm)
L. Overall length – without ripper or front attachment	28 ft 0 in (8 534 mm)
M. Distance between rear tires and rear ripper	6 ft 8 in (2 040 mm)
N. Distance between front tires and front scarifier	5 ft 0 in (1 524 mm)
O. Distance between front tires and front dozer blade	5 ft 5 in (1 645 mm)
Outside tire turning radius	23 ft 11 in (7 289 mm)
Ground clearance – rear axle	14.1 in (359 mm)
Ground clearance – front axle	22.8 in (580 mm)

NOTE: All units equipped with 17.5 x 25-12 PR tires, ROPS cab with heater and A/C, std. battery, full fuel, 175 lb (79 kg) operator. Specifications per ISO 7134.

STANDARD EQUIPMENT

OPERATOR ENVIRONMENT

See page 1

ENGINE

FPT F4HE9684L turbocharged diesel
Tier 3 certified
Temperature controlled cooling fan
Charge air cooler
Air intake grid heater
Common rail electronic fuel injection
Hydraulic driven cooling fan
Auto idle

DRIVETRAIN

Hydraulic differential lock

HYDRAULICS

Closed center, load sensing hydraulic system
Controls for all functions
9 section control valve
Hydraulic moldboard side shift and pitch
5-position saddle
14 ft x 23.6 in (4267 x 600 mm) moldboard
Moldboard Float Control
8 hydraulic diagnostic quick couplers

TIRES

14.0 x 24-12 PR

INSTRUMENTS

Analog displays/Gauges:

Fuel level; Engine coolant temperature;
Transmission oil temperature;
Hydraulic oil temperature.

Monitor functions:

Hour meter; Engine speed; Travel speed;
Current gear selection; FNR indication;
Clock; Trip computer; Fuel consumption;
Fuel level percentage; Oil pressure;
Coolant temperature; Engine oil
temperature; Transmission oil temperature;
Hydraulic oil temperature; Turbocharger air
temperature; Differential lock indicator;
Gear selection indicator; Engine diagnostics;
Transmission diagnostics; System voltage;
Error reporting; Warning prompts; Indicator
warning lamps – main warning, parking
brake, low brake pressure, high beams, turn
signals, hazard lights, low fuel.

ELECTRICAL

(2) Heavy-duty batteries – 1010 CCA
Electronic Systems Monitor
Horn
Alternator – 90 amp
Backup alarm
Headlights
(2) Turn signals front
(2) Tail lights with turn signals, brake lights
Flood lights – cab mounted

TELEMATICS

CASE SiteWatch™ Telematics – includes
hardware and a 3-yr Advanced
data subscription

OPTIONAL EQUIPMENT

MOLDBOARDS

12 ft x 22 in (3658 x 559 mm), involute curve
13 ft x 23.6 in (3962 x 600 mm), involute curve
Extensions – 2 ft (610 mm)
Front Float Control
Lift cylinder/side shift accumulator
Lift cylinder accumulator
Moldboard corner reinforcement

OPERATOR ENVIRONMENT

High profile ROPS/FOPS cab
Front windows openable with rear
window defroster
Lower front wiper/washers
Rear windshield washer
Air suspension seat
Radio, AM/FM with CD player

TIRES

14.0 x 24-12 PR
14.0 x R24 XGLA
14.0 x R24 Snoplus
16.0 x 24-12 PR
17.5 x 25-12 PR
17.5 x 25-16 PR
17.5 x R25 XTLA
17.5 x R25 Snoplus

ELECTRICAL

(2) Front mounted working lights
(2) Floodlights at moldboard
(2) Floodlights at articulation
Snow plow lighting package

OTHER

Bidirectional engine cooling fan
Cold weather package
Fire extinguisher
Strobe light
Tool box – without tools
Deluxe tool box – with tools
Tire inflator kit
Spare wheel
Spare wheel support
Slow moving vehicle sign
Rear pull hook

ATTACHMENTS

Front pull hook
Front counterweight
Front dozer blade
Front scarifier
Front push plate
Front support and lift cylinder
Rear ripper



NOTE: All specifications are stated in accordance with SAE Standards or Recommended Practices, where applicable.

NOTE: All engines are compliant with current EPA emissions requirements.

IMPORTANT: Case Construction Equipment Inc. reserves the right to change these specifications without notice and without incurring any obligation relating to such change. Case Construction Equipment Inc. does not warrant the safety or reliability of attachments from other manufacturers.

CASE is a trademark registered in the United States and many other countries, owned by or licensed to CNH Industrial N.V., its subsidiaries or affiliates. CNH Industrial Capital is a trademark in the United States and many other countries, owned by or licensed to CNH Industrial N.V., its subsidiaries or affiliates.

Form No. CCE201503885BAWD
Replaces form no. CCE201406885BAWD

Printed in U.S.A.
885B AWD • Page 4 of 4



All Case construction equipment is biodiesel ready.



www.casece.com

© 2015 CNH Industrial America LLC
All Rights Reserved

CASE
CONSTRUCTION

B SERIES

MOTOR GRADERS

845B | 865B | 865B AWD | 885B | 885B AWD



A MARVEL OF POWER AND PRECISION.

From a unique moldboard design that rolls a superior mix to a fuel-efficient, turbocharged Tier 3 engine that achieves operating speeds of up to 27 mph to a spacious, rear-mounted cab that gives operators exceptional visibility of the working part of the machine, CASE B Series graders are engineered to deliver a level of productivity others can't match and comfort operators can't deny.



★ Unique Multi-Radius Involute Moldboard

★ Exclusive Front Articulation

★ Externally Driven Circle Teeth

★ All-Wheel Drive with Creep Mode



★ Spacious Cab

★ Protected by ProCare

Models Available



A GREATER GRADER.



ONE-OF-A-KIND MOLDBOARD DESIGN

A consistent aggregate mix is critical to surface quality and pothole prevention. Made from high-carbon steel, the CASE reinforced, multi-radius, involuted moldboard design cuts, mixes and rolls material in an effortless wave that results in a finer mix. Its efficiency requires less horsepower too, saving you fuel. Our moldboard can also pitch, tilt and move laterally to match site demands, and can expand up to 16 feet with optional extensions.



THE ALL-WHEEL DRIVE ADVANTAGE

All-wheel drive (AWD) models deliver incredible responsiveness, improved steering and greater draft control in tricky underfoot conditions such as mud, sand, snow and banks – crucial for faster snow removal and greater performance in ditching or heavy blading applications.

STABILITY STARTS WITH AN A-FRAME

A stout A-frame drawbar offers outstanding stability, thanks to the heavy-duty boxed frame design. Its wide stance supports the industry's largest circle, which is engineered for greater efficiency, requiring less power when turning the circle. Together, their high-strength design provides maximum durability and component life.



SMART, EXTERNALLY DRIVEN CIRCLE TEETH

Unlike others, CASE motor graders are designed with external circle teeth. This self-cleaning, large tooth design provides more contact area to deliver greater leverage when turning the blade under load. And should you hit an obstacle with the blade, the CASE circle pulls away from the drive gear instead of towards it, which can bind it. So there's no need for slip clutches or shear pins.

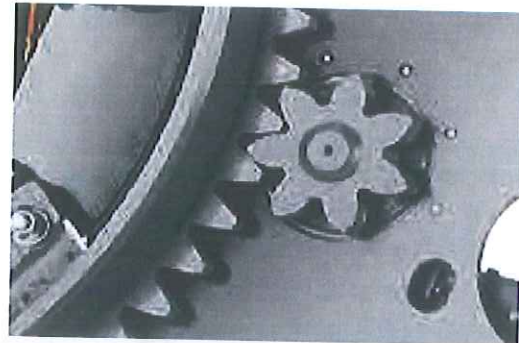

ARTICULATION SETS CASE APART

Cul-de-sacs just got a lot easier. With our industry-exclusive front articulation design, CASE motor graders offer a tight 23' 9" turning radius for quick and accurate machine positioning. With front articulation, the operator maintains the center position while the gooseneck is articulated, allowing for greater visibility to the moldboard, circle, saddle and tires.

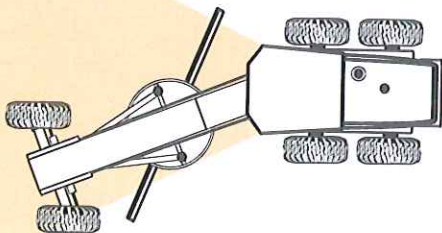





INNER STRENGTHS.

SEE THE CIRCLE, SADDLE, MOLDBOARD AND MORE

The rear-mounted cab of B Series motor graders, combined with floor-to-ceiling windows and heavy-duty breakaway side mirrors, gives operators superior vision of the moldboard, circle, saddle and tires. Even rearward, the sleek, sloping hood and rear defroster provide excellent visibility when reversing.



MASSIVE CAB. MASSIVE COMFORT.

At more than 76 inches tall, the B Series motor graders boast a spacious cab, giving operators plenty of room to stand, move, see and work. The ROPS/FOPS-certified Iso-mount cab also helps minimize noise and vibration for a quiet, comfortable ride. Coupled with the optional deluxe suspension seat with lumbar control, you'll feel less fatigued and more productive throughout the day.



CREEP MODE: PUSH-BUTTON PRECISION

Activated with the push of a button, "Creep Mode" makes it so that only the front wheels are engaged, allowing the machine to move at extremely slow speeds – around 1 mph – for finish grading and where tolerances are critical.



SHOCK-ABSORBING CIRCLE SAVERS

Optional anti-shock accumulators protect circle components by allowing the moldboard to move over obstructions and then return to its original position – no adjustment or operator intervention necessary.



MAINTENANCE MADE EASY.

SERVICEABILITY IS IN OUR DNA

When you invest in CASE equipment, you need it to last. We make it simple. CASE B Series motor graders are no exception. From a one-piece, flip-up hood and a reversible fan option that blows out cooler debris to ground-level site gauges and service points, you can do daily maintenance in a matter of minutes. It's the easiest way to help you get the most performance and longest life out of your machine.

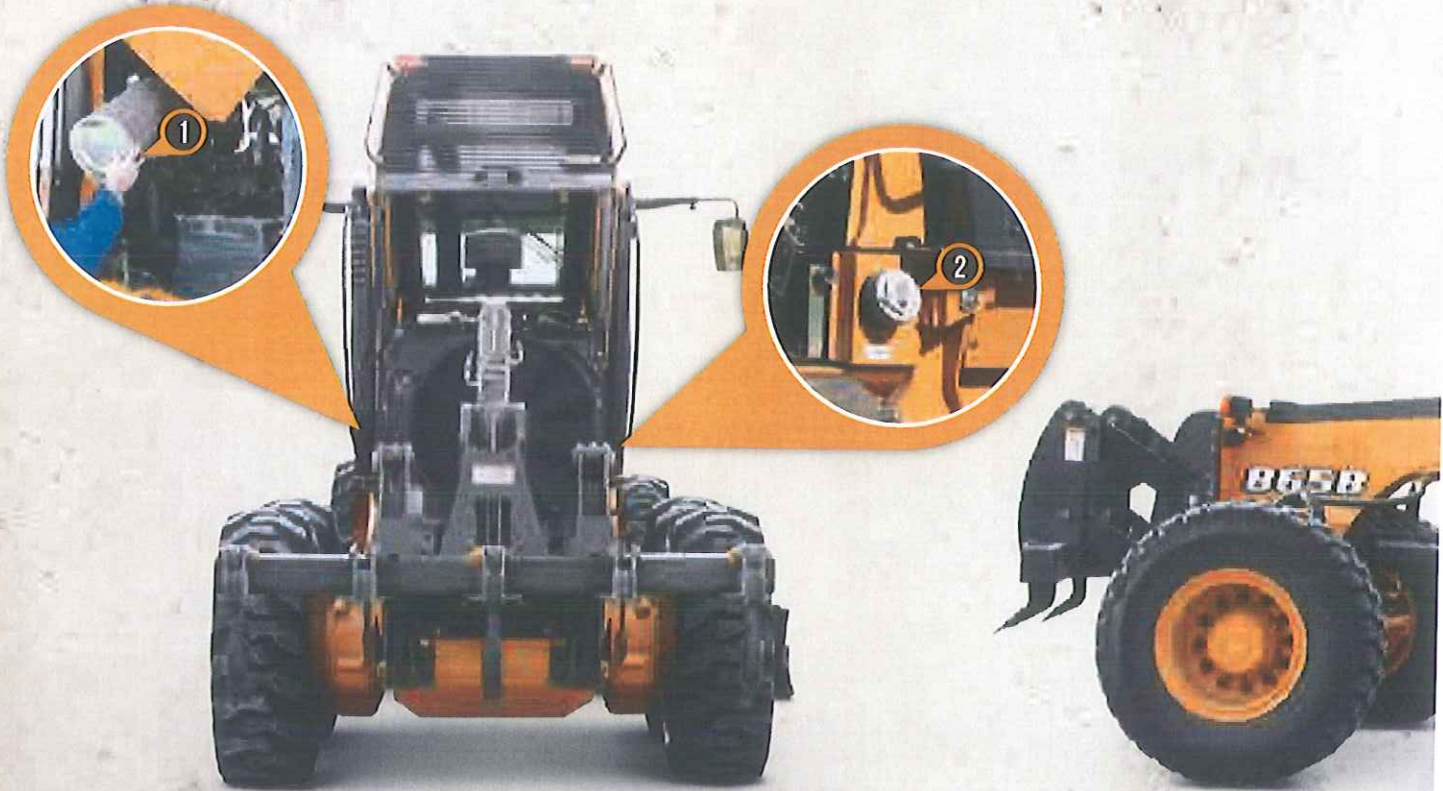

EASY ACCESS TO EVERYTHING

- | | | |
|--------------------------|-------------------------|--------------------|
| 1. Engine air filter | 4. Hydraulic test ports | 7. Site gauges |
| 2. Fuel fill | 5. Grease zerks | 8. Flip-up hood |
| 3. External circle teeth | 6. Swing-out batteries | 9. Oil drain hoses |

SEE A 360° VIEW



CaseCE.com/360



NO TOOLS NEEDED

The B Series motor grader continues the CASE hallmark of simple serviceability with features like tool-free access to routine maintenance points.



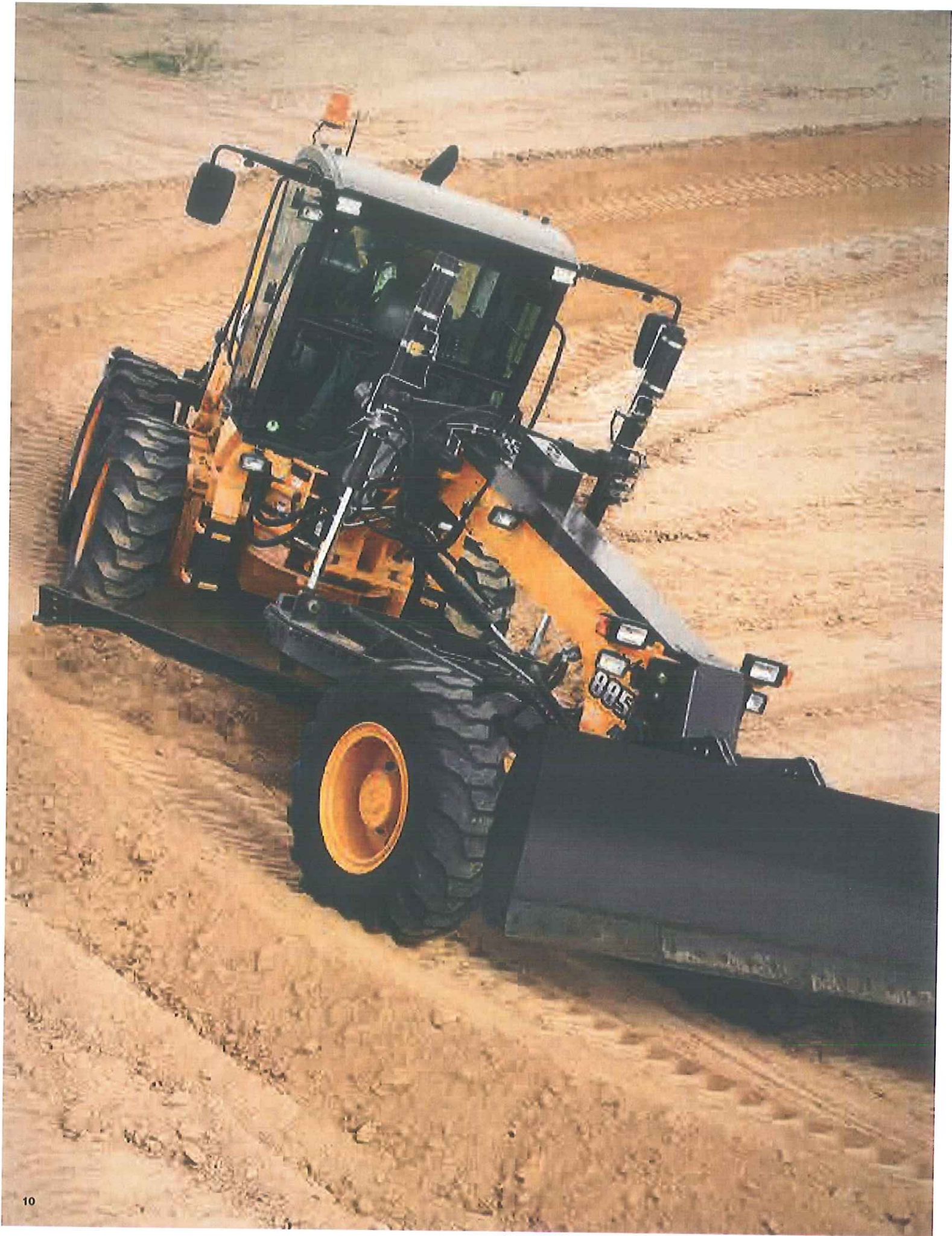

ProCare

GO BIG. WE'VE GOT YOU COVERED.

CASE ProCare is the first all-in-one heavy machine support program that's as powerful as the equipment it protects. Best of all, ProCare comes standard on B Series motor graders and keeps you covered for up to three full years. It's the assurance growing businesses need to stay competitive, productive and profitable.

Breakdown Assistance

Standard on all CASE equipment.



**3-year/3000-hr.
Full-Machine
Factory Limited
Warranty***

We've got your back —
for up to three full years!



**3-year/3000-hr.
Planned
Maintenance**

Don't spend a dime for
CASE-certified scheduled
care – fluids, filters and
labor included.



**3-year Advanced
SiteWatch™
Subscription**

Telematics isn't a
luxury; it's a necessity
— and we've made it
accessible to all.



STRONGER PRODUCT SUPPORT SOLUTIONS

Your CASE dealer knows best how you can maximize your equipment investment and uptime, with genuine CASE parts, expert service and a complete range of product support solutions – including CASE remanufactured and all-makes parts. CASE supports better parts availability and faster deliveries, through nine parts distribution centers in North America and a forecasting system to ensure that the right parts will be there when you need them. And only CASE dealers have exclusive access to the Electronic Service Tool that quickly pinpoints machine issues to help maximize uptime.



*See CNH Warranty and Limitation of Liability for complete terms and limits of warranty. ProCare is a factory-fit program available on select 2013 and later machines.

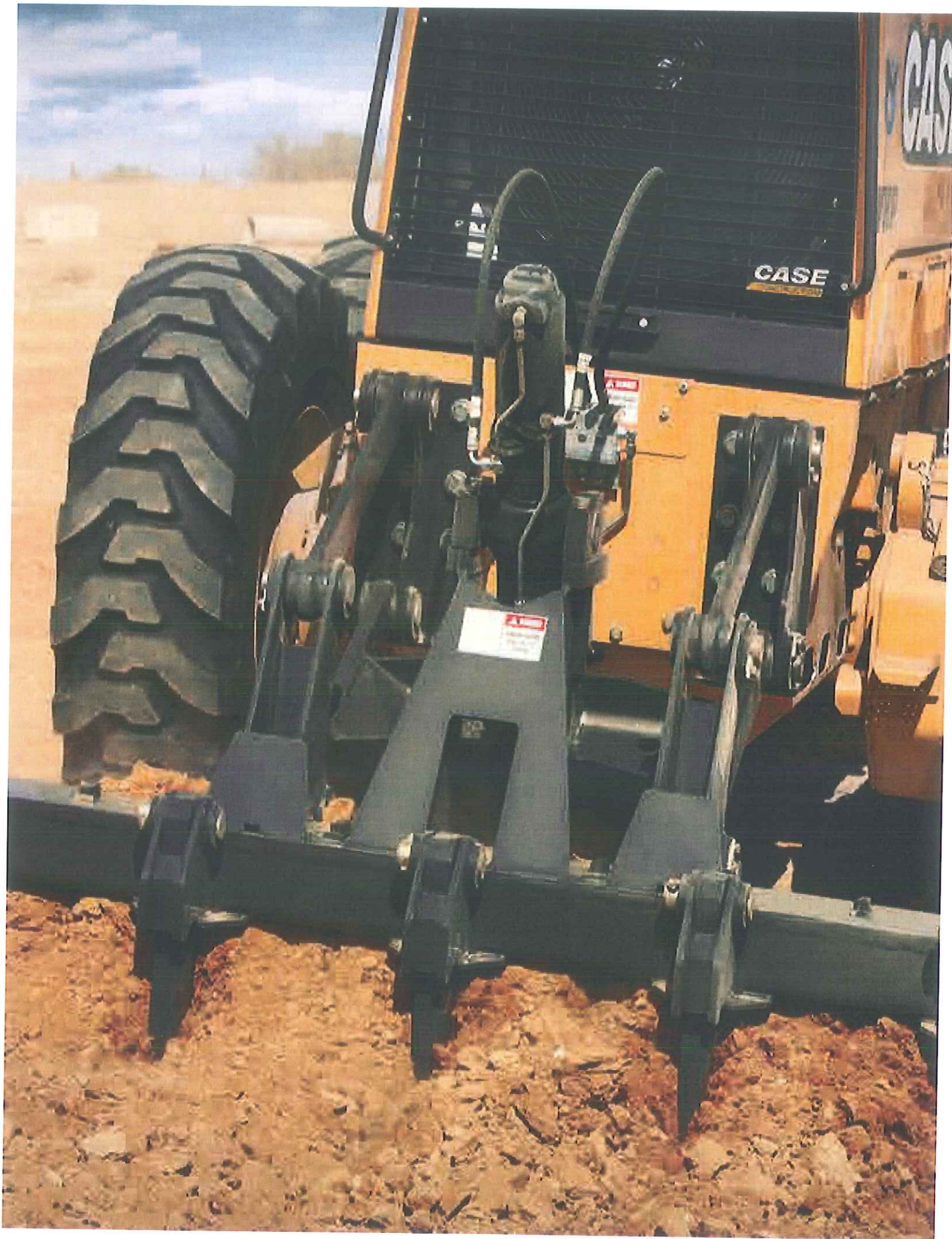

ATTACHED TO STRENGTH.

CASE offers a variety of grader attachments, including:

- Front counterweight
- Ripper
- Scarifier
- Front push plate
light 1,084 lbs. - heavy 1,764 lbs.
- Front dozer blade
- Rear pull hook
- Additional lighting packages
- Lift cylinder accumulators
- Float control
- Moldboard extensions



FRONT COUNTERWEIGHT



RIPPER



SCARIFIER



FRONT PUSH PLATE



FRONT DOZER BLADE



THE B SERIES MOTOR GRADERS



SPECIFICATIONS	845B	865B	865B AWD	885B	885B AWD
Engine	FPT F4HE9687W	FPT F4HE9687C	FPT F4HE9687C	FPT F4HE9687K	FPT F4HE9687K
Gross hp (kW) @2200 RPM	150/173 (112/129)	193/205/220 (144/153/164)	193/205/220 (144/153/164)	220/234 (164/175)	220/234 (164/175)
Emissions rating	Tier 3 Certified	Tier 3 Certified	Tier 3 Certified	Tier 3 Certified	Tier 3 Certified
Engine displacement – in. ³ (L)	409 (6.7)	409 (6.7)	409 (6.7)	409 (6.7)	409 (6.7)
Operating weight – lb. (kg)	31,812 (14 430)	33,797 (15 330)	35,274 (16 000)	39,771 (18 040)	42,198 (18 124)
Blade pressure – lb. (kg)	16,535 (7 500)	18,519 (8 400)	19,048 (8 640)	21,473 (9 740)	22,267 (10 100)
Maximum forward speed – mph (km/h)	27.3 (43.9)	27.8 (44.8)	27.8 (44.8)	27.8 (44.8)	27.8 (44.8)
Peak torque – lbs.-ft (N-m)	486/560 (659/758)	612/649/686 (830/880/930)	612/649/686 (830/880/930)	682/726 (924/984)	682/726 (924/984)
FWD/REV gears	8/4	8/4	8/4	8/4	8/4
Total flow – gpm (L/min)	49 (186)	49 (186)	49 (186)	49 (186)	49 (186)
DIMENSIONS					
Moldboard length	12 ft. 0 in. (3 658 mm)	14 ft. 0 in. (4 267 mm)	14 ft. 0 in. (4 267 mm)	14 ft. 0 in. (4 267 mm)	14 ft. 0 in. (4 267 mm)
Moldboard height	22.0 in. (559 mm)	23.6 in. (600 mm)	23.6 in. (600 mm)	23.6 in. (600 mm)	23.6 in. (600 mm)
Moldboard thickness	0.875 in. (22 mm)	0.875 in. (22 mm)	0.875 in. (22 mm)	0.875 in. (22 mm)	0.875 in. (22 mm)
Distance between outside edges of tires	8 ft. 2 in. (2 499 mm)	8 ft. 1 in. (2 452 mm)	8 ft. 1 in. (2 452 mm)	8 ft. 8 in. (2 650 mm)	8 ft. 8 in. (2 650 mm)
Wheel tread	6 ft. 11 in. (2 106 mm)	6 ft. 11 in. (2 106 mm)	6 ft. 11 in. (2 106 mm)	7 ft. 2 in. (2 174 mm)	7 ft. 2 in. (2 174 mm)
Height to top of low-profile cab	10 ft. 4 in. (3 150 mm)	10 ft. 4 in. (3 150 mm)	10 ft. 4 in. (3 150 mm)	10 ft. 4 in. (3 150 mm)	10 ft. 4 in. (3 150 mm)
Tire radius – when static	2 ft. 0 in. (610 mm)	2 ft. 0 in. (610 mm)	2 ft. 0 in. (610 mm)	2 ft. 0 in. (610 mm)	2 ft. 0 in. (610 mm)
Blade base	8 ft. 5 in. (2 562 mm)	8 ft. 5 in. (2 562 mm)	8 ft. 5 in. (2 562 mm)	8 ft. 5 in. (2 562 mm)	8 ft. 5 in. (2 562 mm)
Distance between tandem axles	5 ft. 2 in. (1 572 mm)	5 ft. 3 in. (1 594 mm)	5 ft. 3 in. (1 594 mm)	5 ft. 4 in. (1 624 mm)	5 ft. 4 in. (1 624 mm)
Distance between tandem center and wheel	2 ft. 7 in. (786 mm)	2 ft. 7 in. (797 mm)	2 ft. 7 in. (797 mm)	2 ft. 8 in. (812 mm)	2 ft. 8 in. (812 mm)
Wheelbase	20 ft. 5 in. (6 219 mm)	20 ft. 5 in. (6 219 mm)	20 ft. 5 in. (6 219 mm)	20 ft. 5 in. (6 219 mm)	20 ft. 5 in. (6 219 mm)
Overall length – without ripper or front attachment	28 ft. 0 in. (8 534 mm)	28 ft. 0 in. (8 534 mm)	28 ft. 0 in. (8 534 mm)	28 ft. 0 in. (8 534 mm)	28 ft. 0 in. (8 534 mm)
Turning radius	23 ft. 9 in. (7 250 mm)	23 ft. 9 in. (7 250 mm)	23 ft. 9 in. (7 250 mm)	23 ft. 11 in. (7 289 mm)	23 ft. 11 in. (7 289 mm)

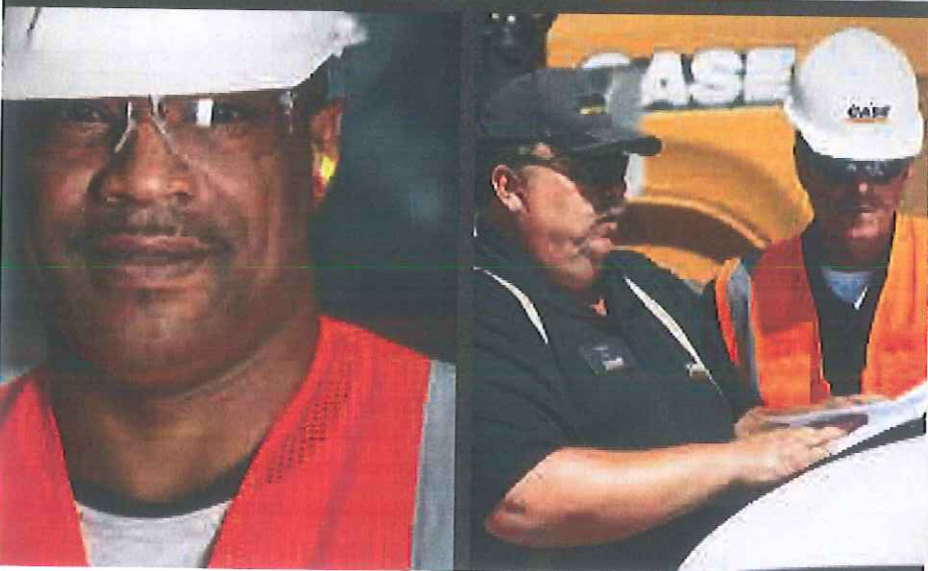
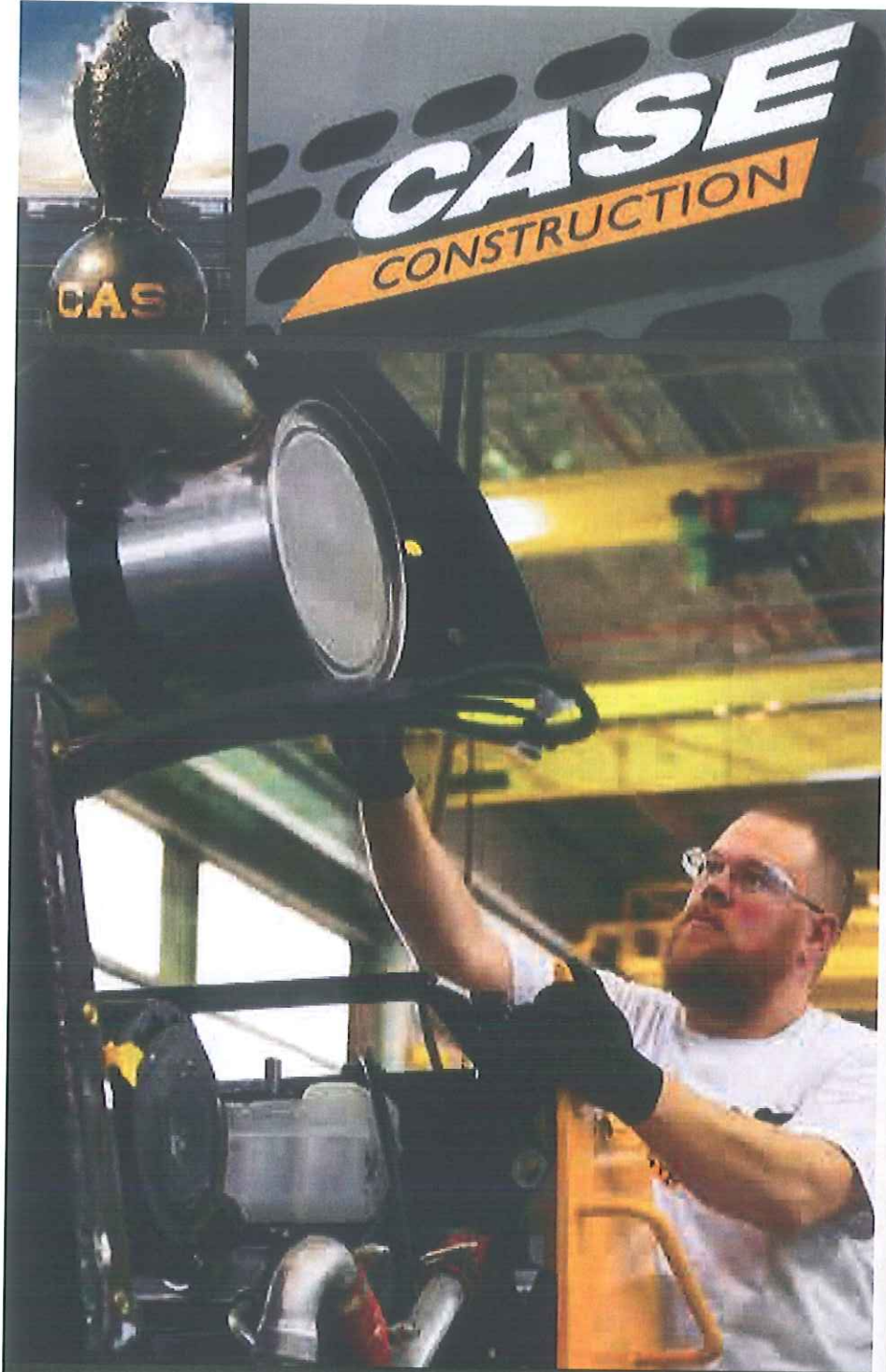

BUILDING A STRONG CASE

Already in high gear with the arrival of founder J.I. Case's portable steam engine in 1869, we found ourselves at the heart of the road construction boom of the early 1900s. The path was set. Today, CASE is a game changer in construction equipment, financing, parts and service.

Revolutionary is nothing new to CASE, as innovations like the integrated backhoe loader (1957), Ride Control™, over-center boom design and ProCare have shown. It's this ingenuity and spirit that fuels our ongoing pursuit of building industry-leading performance and productivity into every machine throughout our full line of light to heavy equipment.

All of this is backed by a portfolio of more than 10,000 OEM, REMAN and Gold Value parts, more than 350 North American dealer locations, and unmatched financial and insurance services that ensure the best support is always within reach. When all is said and done, our strength is only as solid as the machines we engineer, the support and service we give, and most importantly, the vote of confidence CASE customers have with every bit of it.



Specialized finance programs and flexible leasing packages put you in the driver's seat of industry-leading CASE equipment, while no-nonsense warranties and comprehensive protection plans ensure that your equipment is protected. As the only finance company dedicated to CASE, we offer strong products and services designed around your unique needs and are the only ones supported by the helpful service professionals at your CASE dealer.

To learn more about CASE or for attentive customer service, visit your nearest dealer, call 1-866-54-CASE6 or visit us online at CaseCE.com.





CaseCE.com



©2014 CNH Industrial America LLC. All rights reserved. CASE is a trademark registered in the United States and many other countries, owned by or licensed to CNH Industrial N.V., its subsidiaries or affiliates. CNH Industrial Capital is a trademark in the United States and many other countries, owned by or licensed to CNH Industrial N.V., its subsidiaries or affiliates. Printed in U.S.A.

Form No. CCE201404MG
Replaces Form No. CCE201401MG



**SAFETY™
NEVER HURTS**

Always read the Operator's Manual before operating any equipment. Inspect equipment before using it, and be sure it is operating properly. Follow the product safety signs and use any safety features provided.

NOTE: All engines meet current EPA emissions regulations.
NOTE: All specifications are stated in accordance with SAE Standards or Recommended Practices, where applicable.



Contains 10%
post-consumer fiber

IMPORTANT: CASE Construction Equipment Inc. reserves the right to change these specifications without notice and without incurring any obligation relating to such change. Availability of some models and equipment builds vary according to the country in which the equipment is used. The illustrations and text may include optional equipment and accessories and may not include all standard equipment. Your CASE dealer/distributor will be able to give you details of the products and their specifications available in your area.



CASE Construction Equipment
is biodiesel-friendly.