

**Missouri Department of Transportation**  
*David B. Nichols, Director*

573.751.2551  
Fax: 573.751.6555  
1.888.ASK MODOT (275.6636)

**ADDENDUM 004**  
**Supplemental Guide Sign Program**  
**Request for Proposal 6-150504DR**

Offerors should acknowledge receipt of Addendum 004 (FOUR) by **signing** and **including it** with the original proposal. The due date for receipt of proposals is **unchanged** by this Addendum. The following changes shall be included as mandatory requirements for this solicitation. All other terms and conditions remain unchanged and in full force.

Name and Title of Signer (Print or type)	Name and Title of Department Authority  Debbie Rickard General Services Director
Contractor/Offeror Signature  <hr/> (Signature of person authorized to sign)	Department of Transportation  <i>Debbie Rickard</i> (Authorizing Signature)
Date Signed:	Date Signed: <i>April 23, 2015</i>

Offerors are notified of the following changes. All are identified in the attached RFP as **Addendum 004** changes.

- Section 4: Evaluation Factors and Process 1. Evaluation Criteria (a.) and (b.) were clarified.
- Section 6: Pricing Page (1) Payments to MHTC was modified.

**Missouri Department of Transportation**  
*David B. Nichols, Director*

573.751.2551  
Fax: 573.751.6555  
1.888.ASK MODOT (275.6636)

**ADDENDUM 004**  
**Supplemental Guide Sign Program**  
**Request for Proposal 6-150504DR**

Offerors should acknowledge receipt of Addendum 004 (FOUR) by **signing** and **including it** with the original proposal. The due date for receipt of proposals is **unchanged** by this Addendum. The following changes shall be included as mandatory requirements for this solicitation. All other terms and conditions remain unchanged and in full force.

Name and Title of Signer (Print or type)	Name and Title of Department Authority  Debbie Rickard General Services Director
Contractor/Offeror Signature  _____ (Signature of person authorized to sign)	Department of Transportation  <i>Debbie Rickard</i> (Authorizing Signature)
Date Signed:	Date Signed: <i>April 23, 2015</i>

Offerors are notified of the following changes. All are identified in the attached RFP as **Addendum 003** changes.

- Section 4: Evaluation Factors and Process 1. Evaluation Criteria (a.) and (b.) were clarified.
- Section 6: Pricing Page (1) Payments to MHTC was modified.

**Missouri Department of Transportation**  
*David B. Nichols, Director*

573.751.2551  
Fax: 573.751.6555  
1.888.ASK MODOT (275.6636)

**ADDENDUM 003**  
**Supplemental Guide Sign Program**  
**Request for Proposal 6-150504DR**

Offerors should acknowledge receipt of Addendum 003 (THREE) by **signing** and **including it** with the original proposal. The due date for receipt of proposals is **unchanged** by this Addendum. The following changes shall be included as mandatory requirements for this solicitation. All other terms and conditions remain unchanged and in full force.

Name and Title of Signer (Print or type)	Name and Title of Department Authority  Debbie Rickard General Services Director
Contractor/Offeror Signature  <hr/> (Signature of person authorized to sign)	Department of Transportation  <i>Debbie Rickard</i> (Authorizing Signature)
Date Signed:	Date Signed: <i>April 17, 2015</i>

Offerors are notified of the following changes. All are identified in the attached RFP as **Addendum 003** changes.

- Section 2: Scope of Work and Specific Services (8) Contracts was clarified.
- Section 3: Required Elements of Proposal and Submission (A) (1) Experience and Performance f. was modified.
- Section 4: Evaluation Factors and Process 1. Evaluation Criteria (a.) and (b.) were clarified.
- Section 5: Terms and Conditions (Z) Bonding was modified.
- Attachment L was modified to include additional revenue information.

**Missouri Department of Transportation**  
*David B. Nichols, Director*

573.751.2551  
Fax: 573.751.6555  
1.888.ASK MODOT (275.6636)

**ADDENDUM 002**  
**Supplemental Guide Sign Program**  
**Request for Proposal 6-150504DR**

Offerors should acknowledge receipt of Addendum 002 (TWO) by **signing** and **including it** with the original proposal. The due date for receipt of proposals is **unchanged** by this Addendum. The following changes shall be included as mandatory requirements for this solicitation. All other terms and conditions remain unchanged and in full force.

Name and Title of Signer (Print or type)	Name and Title of Department Authority  Debbie Rickard General Services Director
Contractor/Offeror Signature  <hr/> (Signature of person authorized to sign)	Department of Transportation  <i>Debbie Rickard</i> (Authorizing Signature)
Date Signed:	Date Signed: <i>April 10, 2015</i>

Offerors are notified of the following changes. All are identified in the attached RFP as **Addendum 002** changes.

- Table of Contents: Changes to correct page numbers as a result of this addendum and corrected titles of Attachments F & G
- Section 1: General Description and Background, (D) Schedule of Events: Changed the deadline for written questions and requests for clarifications.
- Section 2: Scope of Work and Specific Services (16) Contract Amendments was modified to allow specific circumstances for price increases or decreases.
- Section 3: Required Elements of Proposal and Submission (A) (3) Reporting and (5) Program Implementation required elements were modified.

- Section 4: Evaluation Factors and Process 1. Evaluation Criteria (a.) was clarified.
- Section 5: Terms and Conditions (Z) Bonding was modified to add Proposal Guaranty and Contract Bond was modified.
- Section 6: Pricing Page (1) Payments to MHTC calculation clarification was added, (2) Initial Payment was clarified, and (3) the Construction and Maintenance Costs for Existing MoDOT Signs was clarified.
- Exhibit 4: Proposal Bond was added.
- Attachment L was modified to include new contract information for Fiscal Years 2013 and 2014 and the net increase in contracts in the two years.

**Missouri Department of Transportation**  
*David B. Nichols, Director*

573.751.2551  
Fax: 573.751.6555  
1.888.ASK MODOT (275.6636)

**ADDENDUM 001**  
**Supplemental Guide Sign Program**  
**Request for Proposal 6-150504DR**

Offerors should acknowledge receipt of Addendum 001 (ONE) by **signing** and **including it** with the original proposal. The due date for receipt of proposals is **unchanged** by this Addendum. The following changes shall be included as mandatory requirements for this solicitation. All other terms and conditions remain unchanged and in full force.

Name and Title of Signer (Print or type)	Name and Title of Department Authority  Debbie Rickard General Services Director
Contractor/Offeror Signature  _____ (Signature of person authorized to sign)	Department of Transportation  <i>Debbie Rickard</i> (Authorizing Signature)
Date Signed:	Date Signed: <i>April 3, 2015</i>

Offerors are notified of the following changes.

- Any references to Central Standard Time shall be replaced with Central Time.
- Page 20, Section 3, Paragraph (B) 7, Pre-proposal Conference (not required). We are adding the option of participating in the pre-proposal conference via teleconference. Any Offeror interested in participating via teleconference must contact the Buyer of Record no later than 3:00 pm Central Time on April 6, 2015.
- Revision of Attachment L as attached.



*Our mission is to provide a world-class transportation experience that  
delights our customers and promotes a prosperous Missouri.*

[www.modot.org](http://www.modot.org)

**Missouri Department of Transportation**  
*David B. Nichols, Director*

573.751.2551  
Fax: 573.751.6555  
1.888.ASK MODOT (275.6636)

CCO Form: GS  
Approved: 2/15 (AR)

**REQUEST FOR PROPOSALS  
FOR  
SUPPLEMENTAL GUIDE SIGN PROGRAM  
RFP # 6-150504DR**

**TABLE OF CONTENTS**

<b>INTRODUCTION.....</b>	<b>4</b>
<b>PROPOSAL SUBMITTAL CERTIFICATION .....</b>	<b>5</b>
<b>SECTIONS:</b>	
<b>1. GENERAL DESCRIPTION AND BACKGROUND .....</b>	<b>6</b>
(A) Request for Proposal.....	6
(B) Background .....	6
(C) Contract Period .....	6
(D) Schedule of Events .....	6
<b>2. SCOPE OF WORK AND SPECIFIC SERVICES .....</b>	<b>7</b>
(A) Scope of Work .....	7
(B) Specific Services .....	7
<b>3. REQUIRED ELEMENTS OF PROPOSAL AND SUBMISSION.....</b>	<b>17</b>
(A) Required Elements of Proposal .....	17
1. Experience and Performance.....	17
2. Marketing .....	18
3. Reporting .....	18
4. Program Cost and Revenue .....	18
5. Program Implementation .....	18
(B) Submission of Proposals .....	19
1. Proposal Format.....	19
2. Signatures .....	19
3. Pricing .....	19
4. Proposal Life.....	19
5. Submission of All Information Required.....	19
6. Public Inspection .....	19
7. Pre-proposal Conference.....	20
8. Clarification of Requirements .....	20
9. Oral presentation .....	21
10. Official Position of MHTC .....	21

<b>4. EVALUATION FACTORS AND PROCESS .....</b>	<b>21</b>
<b>(A) Evaluation Factors .....</b>	<b>21</b>
<b>1. Evaluation Criteria .....</b>	<b>21</b>
<b>2. Historical Information.....</b>	<b>22</b>
<b>3. Responsibility to Submit Information.....</b>	<b>22</b>
<b>(B) Proposal Review/Evaluation .....</b>	<b>23</b>
<b>5. TERMS AND CONDITIONS.....</b>	<b>23</b>
<b>(A) Agreement Components .....</b>	<b>23</b>
<b>(B) MHTC’s Representative.....</b>	<b>23</b>
<b>(C) Assignment.....</b>	<b>23</b>
<b>(D) Amendments.....</b>	<b>24</b>
<b>(E) Disputes Under the RFP and Resulting Agreement .....</b>	<b>24</b>
<b>(F) Successors and Assigns .....</b>	<b>24</b>
<b>(G) Sole Beneficiary.....</b>	<b>24</b>
<b>(H) Cancellation of Resulting Agreement.....</b>	<b>24</b>
<b>(I) Bankruptcy .....</b>	<b>24</b>
<b>(J) Status as Independent Contractor.....</b>	<b>24</b>
<b>(K) Subcontractor .....</b>	<b>24</b>
<b>(L) MBE/WBE Participation Encouraged.....</b>	<b>25</b>
<b>(M) Nondiscrimination.....</b>	<b>25</b>
<b>(N) Executive Order .....</b>	<b>25</b>
<b>(O) Non-employment of Unauthorized Aliens .....</b>	<b>26</b>
<b>(P) Proof of Lawful Presence for Sole Proprietorships and Partnerships.....</b>	<b>26</b>
<b>(Q) Offeror Requirements .....</b>	<b>26</b>
<b>(R) Law of Missouri to Govern .....</b>	<b>27</b>
<b>(S) Venue.....</b>	<b>27</b>
<b>(T) Ownership of Reports.....</b>	<b>27</b>
<b>(U) Release to Public/Confidentiality.....</b>	<b>27</b>
<b>(V) Prohibition Against Kickbacks and Gratuities/Nonsolicitation .....</b>	<b>27</b>
<b>(W) Conflict of Interest .....</b>	<b>27</b>
<b>(X) Audit of Records .....</b>	<b>28</b>
<b>(Y) Indemnification .....</b>	<b>28</b>
<b>(Z) Bonding.....</b>	<b>28</b>
<b>(AA) Insurance .....</b>	<b>29</b>
<b>(BB) Section Headings .....</b>	<b>29</b>
<b>(CC) Severability .....</b>	<b>29</b>
<b>(DD) No Adverse Inference .....</b>	<b>30</b>
<b>6. PRICING PAGE .....</b>	<b>31</b>

**LIST OF ACRONYMS**

**EPG**            Engineering Policy Guide  
**Logos**         Specific Service Signing  
**MHTC**         Missouri Highways and Transportation Commission  
**MoDOT**        Missouri Department of Transportation  
**MUTCD**        Manual of Uniform Control Devices  
**RFP**            Request for Proposals  
**SGSP**         Supplemental Guide Sign Program  
**TODS**         Tourist Oriented Directional Sign

*Amended by Addendums 002 and 003*

**Exhibit 1:** Annual Worker Eligibility Verification Affidavit .....36  
**Exhibit 2:** Applicant Affidavit for Sole-Proprietorship or Partnership.....37  
**Exhibit 3:** Contract Bond .....38  
**Exhibit 4: Proposal Bond** .....40  
**Attachment A:** Proposed Administrative Rules  
**Attachment B:** Draft EPG Policy  
**Attachment C:** Applicable Missouri Standard Plans for Highway Construction  
**Attachment D:** Applicable Missouri Specifications for Highway Construction  
**Attachment E:** Applicable Approved Products List  
**Attachment F:** *Example Signs- Traffic Generator, Colleges, Welcome Center Affiliate and State Correctional Centers*  
**Attachment G:** *Example Signs-State and Federal Agencies*  
**Attachment H:** Material Specifications  
**Attachment I:** Overlay Specifications  
**Attachment J:** Federal Minimum Retroreflectivity Standards  
**Attachment K:** Draft General Provisions  
**Attachment L:** Estimated Number of Signs in Each Program

## INTRODUCTION

*Amended by Addendum 001*

This Request For Proposal (**RFP**) seeks proposals from qualified organizations (**Offerors**) to administer the supplement guide sign program for the Missouri Highways and Transportation Commission (“**MHTC**” or “**Commission**”) and its operating arm, the Missouri Department of Transportation (“**MoDOT**”). Proposals in the required format provided for in this RFP must be mailed in a sealed envelope or box, or else delivered by hand or courier service (UPS, Federal Express, DHL, etc.) to be **received on or before, 2:00 p.m. Central Time, May 4, 2015** , at the office of the RFP Buyer of Record:

Debbie Rickard  
General Services Director  
Missouri Department of Transportation  
Central Office General Services  
Hand Delivered/Courier Service:  
830 MoDOT Drive; P.O. Box 270, Jefferson City, MO 65109  
US Postal Service: P.O. Box 270, Jefferson City, MO 65102  
Email: Debbie.Rickard@modot.mo.gov

All documents must be sealed and should be clearly marked “**RFP 6-150504DR - SUPPLEMENTAL GUIDE SIGN PROGRAM**”.

MHTC reserves the right to reject any and all proposals for any reason whatsoever. Time is of the essence for responding to the RFP within the submission deadlines.

**PROPOSAL SUBMITTAL CERTIFICATION BY OFFEROR**

- (1) The Offeror shall provide a fee proposal to MHTC in accordance with the terms of this RFP.
- (2) The Offeror agrees to provide the services at the fees quoted, under the terms of this RFP.
- (3) By submission of this proposal, each Offeror and each person signing on behalf of any Offeror, and in the case of a joint proposal, each party thereto as to its own organization, under penalty of perjury, certifies to the best of its knowledge and belief:
  - (A) The prices in this proposal have been arrived at independently without collusion, consultation, communication or agreement, for the purpose of restricting competition, as to any matter relating to such prices with any other Offeror or any competitor; and
  - (B) Unless otherwise required by law, the prices which have been quoted in this proposal have not been knowingly disclosed by the Offeror prior to the opening, directly or indirectly, to any other Offeror or to any competitor; and
  - (C) No attempt has been made or will be made by the Offeror to induce any other person, partnership or corporation to submit or not to submit a proposal for the purpose of restricting competition.
  - (D) The Offeror certifies that this proposal is made without any connection with any other person/firm/organization/business entity making a proposal for the same purpose, and is in all respects fair and without collusion or fraud, and that no elected official or other member, officer or employee or person whose salary is payable in whole or in part from the MHTC/MoDOT is directly or indirectly interested therein, or in any portion of the profits thereof.

Authorized Signature of Offeror: \_\_\_\_\_

Date of Proposal: \_\_\_\_\_

Printed or Typed Name: \_\_\_\_\_

Mailing Address: \_\_\_\_\_

City: \_\_\_\_\_ State: \_\_\_\_\_ Zip: \_\_\_\_\_

Telephone: \_\_\_\_\_ Fax: \_\_\_\_\_

Electronic Mail Address: \_\_\_\_\_

\_\_\_\_\_

**SECTION 1:  
GENERAL DESCRIPTION AND BACKGROUND**

**(A) Request for Proposal:** This document constitutes a RFP from qualified organizations to administer the supplemental guide sign program (SGSP) for MHTC/MoDOT as set forth in this RFP.

**(B) Background:** MHTC currently outsources the administration of its Tourist Oriented Directional Signing (TODS) and Specific Service Signing (Logos) programs, with the current contract expiring June 30, 2015. This request for proposal also includes other supplemental signing programs as part of this RFP. This provides a single point of contact for all similar services for potential program applicants.

**(C) Contract Period:** The Contract Period for the performance of this RFP is from the date of the fully executed Resulting Agreement through June 30, 2020, with one optional five (5) year extension. The successful Offeror shall perform any and all services listed herein for the entire duration of the Contract Period as submitted by the successful Offeror in response to **SECTION 6: PRICING PAGE** of this RFP.

*Amended by Addendums 001 and 002*

**(D) Schedule of Events:** Below is the schedule that may be followed. Unless otherwise specified, the time of day will be 7:30 a.m. to 4:00 p.m. Central Time. MHTC reserves the right at its sole discretion to expand this schedule, as deemed necessary, without any notification except for the deadline date for submitting a proposal.

DATE	EVENT
March 26, 2015	Issue RFP to solicit proposals.
April 7, 2015	Pre-Proposal Conference (Non-Mandatory)
<i>April 14, 2015 4:00 pm CT</i>	Deadline for Offerors to submit written questions and requests for clarification to the RFP Buyer of Record.
April 17, 2015	Issuance of Amendment with resolution of any questions submitted.
May 4, 2015	Deadline for submission of proposals and scheduled public reading of the names of Offerors submitting timely received proposals.
May 11 – 13, 2015	Oral presentations at the discretion of the evaluation team
May 15, 2015	Contract issued to successful Offeror
<i>June 6, 2015</i>	<i>Contract approval included on Commission Agenda</i>

## **SECTION 2: SCOPE OF WORK AND SPECIFIC SERVICES**

**(A) Scope of Work:** The successful Offeror agrees to administer the MHTC's SGSP. These programs include TODS, Logos and Traffic Generators. Traffic Generator shall refer to signs for tourist oriented activity sites, Colleges, State and Federal Agencies (state and federally owned and operated public accesses, public lands, recreation areas, waterways, etc.), Welcome Center Affiliates (tourist information centers) and State Correctional Centers. The sign programs included in this RFP only apply to MHTC owned right of way unless otherwise specified. The scope of work includes administration of all aspects of the MHTC's SGSP, including, but not limited to installing, removing, maintaining, repairing, locating, relocating and fabricating signs, panels, and support structures and program administration. Program administration shall include, but is not limited to, marketing to potential program participants, collecting fees from participants, responding to customer service inquiries, and maintaining records of participants as well as detailed history records related to the signs themselves. All programs will be operated within the specifications outlined in this RFP.

**(B) Specific Services:** The successful Offeror agrees to administer the following programs in conformance with the most current Missouri Code of State Regulations (ATTACHMENT A), MoDOT Policy as published in the Engineering Policy Guide (EPG) (ATTACHMENT B) and the most current edition of the Manual of Uniform Traffic Control Devices (MUTCD) unless otherwise directed by the MHTC.

### **(1) Supplemental Guide Sign Programs:**

- a. Logos: Specific Service Signing directing motorists to qualifying GAS, FOOD, LODGING, CAMPING, TOURIST ORIENTED ACTIVITY SITES and 24 HOUR PHARMACIES.
- b. TODS: Tourist Oriented Directional Signs directing motorists to qualifying GAS, FOOD, LODGING, CAMPING, and TOURIST ORIENTED ACTIVITY SITES.
- c. Traffic Generator Signing: Supplemental Guide signs directing motorists to qualifying Tourist Oriented Activity Sites.
- d. College Signing: Supplemental Guide signs directing motorists to qualifying 2 and 4 year colleges or universities.
- e. State and Federal Signing: Supplemental Guide signs directing motorists to qualifying State and Federal agency owned and operated sites, including, but not limited to conservation areas, public lands, state parks, state historic sites, forests, river accesses, campgrounds and lakes.

- f. Welcome Center Affiliate Signing: Supplemental Guide signs directing motorists to qualifying welcome center affiliates, which are tourist information centers certified by the Missouri Department of Tourism.
- g. State Correctional Center Signing: Supplemental Guide signs directing motorists to qualifying correctional center facilities owned and operated by the Missouri Department of Corrections.

(2) **Signs**: The successful Offeror will be responsible for fabrication, erection, installation, inspection, removals, repairs, locations, relocations and maintenance of all signs, panels, legend, sheeting, substrate, and support structures for all new signs, as well as those signs existing before this award.

- a. Site Review for New Sign Installations: The successful Offeror shall provide a site review for every new sign installation to the MoDOT district sign representative. The MoDOT representative will review the proposed signing plan and either approve the work or suggest an alternate plan before the successful Offeror may install any new signing.
- b. All signs constructed and maintained shall be in accordance with the following:
  - i. Federal Standards: Shall be in accordance with the MUTCD, unless otherwise directed by MoDOT Standards or the MHTC.
  - ii. MoDOT Standards: The latest editions of the Missouri Standard Specifications for Highway Construction, Standard Plans for Highway Construction and MoDOT's Approved Products List, (ATTACHMENTS – C, D and E).
- c. Sign Design Standards: The successful Offeror shall be responsible for designing and fabricating all TODS and Logos signing in accordance with the MUTCD and MoDOT Standards. The successful Offeror shall be responsible for fabricating Traffic Generator signing in accordance with the sign details provided for each specific site by MoDOT. Examples of standard sign designs can be found in ATTACHMENTS – F and G.
- d. Sign Materials: ATTACHMENT - H lists the acceptable materials for use in the fabrication, installation and maintenance of signs in this program. All materials shall meet the minimum requirements found in the most current MoDOT Standards at the time a sign is fabricated, installed or replaced. In the future, upon mutual agreement of both parties, a variation in materials may be considered.

**(3) Sign Maintenance:** The successful Offeror shall maintain all of the MHTC's signs and structures, both on and off the MHTC's Right-of-Way, for all supplemental signs programs in this contract.

- a. Maintenance: Maintenance shall include, but is not limited to, repairing damaged signs or poles, replacing faded signs, ensuring signs remain aesthetically pleasing and plumb, repairing weather damage, fixing regular wear on the signs and removing signs for participants that no longer participate in the SGSP or participants whose contracts have expired or have been cancelled.
- b. Refurbishment: Sign face overlays may be utilized to refurbish structurally sound signs fabricated with extruded aluminum substrates. Sign overlays shall be in compliance with the standards outlined in ATTACHMENT - I. Signs fabricated with flat sheet aluminum substrates shall be replaced with new signs. Any sign deficiencies, including but not limited to, sign mounting heights, post sizes, damage to post or sign supports out of plumb identified during this refurbishment process shall be corrected at the same time as the refurbishment.
- c. Minimum Sign Retroreflectivity: The successful Offeror shall maintain the retroreflectivity of all signs in the SGSP, including logo panels and college emblem panels, to the minimum levels specified in the latest version of the MUTCD. Standards for signs with blue and brown backgrounds have been established since the release of the 2009 MUTCD; see ATTACHMENT - J for updated minimum retroreflectivity requirements. The successful Offeror shall adopt one of the approved evaluation methods listed in the MUTCD for maintaining retroreflectivity and is solely responsible for ensuring signs meet these standards independent of MoDOT's quality assurance inspections.
- d. Removal of Empty Logo Signs: Mainline and ramp logo signs that remain empty for any consecutive six (6) month period shall be removed at the expense of the successful Offeror.
- e. Repair Requirements: The successful Offeror shall maintain any sign erected pursuant to this Agreement to ensure the signs and sign structures remain in good repair, legible, visible, and in a manner that does not pose a safety concern to the traveling public. If the MHTC determines that a sign is not maintained in good repair or presents a danger to the public, the MHTC will notify the successful Offeror and the successful Offeror shall immediately repair the sign. Immediate shall be defined as no more than fourteen (14) calendar days from the time the successful Offeror received notice a repair is needed. If additional time is required to complete the repair the extension must be granted by MoDOT.

**(4) Inspections:**

- a. MoDOT Quality Assurance (QA) Inspections: Signs included in this program will be included in MoDOT's routine sign inspection program. MoDOT personnel will report identified deficiencies to the successful Offeror. The successful Offeror must correct the deficiencies and return the signs to MoDOT Standards with no additional funding from the participant or MoDOT.
- b. Inspection of new signs: The successful Offeror is solely responsible for inspecting the installation of new signs under this program to ensure they meet all standards identified in the RFP. If the installation is found to be substandard, the successful Offeror is responsible for correcting the deficiency with no additional funding from the participant or MoDOT.
- c. Inspection of repaired signs: The successful Offeror is solely responsible for inspecting the repair work performed on any sign under this program to ensure they meet all standards identified in the RFP. If the repair does not meet MoDOT Standards, the successful Offeror is responsible for correcting the deficiency with no additional funding from the participant or MoDOT.

**(5) Modification of Program Signing Due to Construction or other MoDOT Related Activities:** The successful Offeror will not be responsible for assuming the costs for the modification, removal, replacement, temporary or permanent relocation of sign structures related to this contract which are required as a result of a MoDOT construction project or maintenance operations. However, the successful Offeror shall assume complete and total responsibility for coordinating these activities. For construction projects the successful Offeror shall refer to ATTACHMENT – K and for maintenance operation the MoDOT district representative will contact the successful Offeror. The charges for the work completed will be calculated based on the components of the sign assembly which were modified or altered. The cost for each component modification will be at the established price on the successful Offeror's pricing page.

*Amended by Addendum 002*

- (6) Administration:** Successful Offeror shall be responsible for administering all business aspects of this program, including, but not limited to, marketing the SGSP to potential participants, collecting fees from participants, responding to customer service inquiries, and ensuring the program is operated in compliance with the terms of the contract and the references found within.
- a. Marketing: The successful Offeror shall develop marketing tools (informational brochures, news releases, database, reports, web site(s), etc.) for use by both MoDOT and the successful Offeror. All marketing

tools shall be reviewed and approved by the MHTC prior to use. Such tools shall provide information related to each program including, but not limited to, outlining the purpose and application of each program, the eligibility criteria of each program and the fee structure of each program, in a clear and concise format to aid potential applicants in understanding the program most suitable for their business.

- b. Office Requirements: The successful Offeror shall establish an office in Missouri with full-time personnel sufficient to respond to departmental and business customers' requests and inquiries during normal office hours. Normal office hours shall be 8:00 a.m. to 5:00 p.m. **Central Time**, Monday through Friday, with the exception of official State Holidays. Preferred office location is Jefferson City, Missouri.
- c. Forms including Applications and/or Contracts: The successful Offeror is responsible for development of all program forms, applications and contracts. The MHTC shall approve all forms, applications and contracts between the successful Offeror and the participant for each of the programs included in this RFP.
- d. Recordkeeping: The successful Offeror shall maintain complete records in a format compatible with Microsoft Office to provide the following information:
  - i. All inquiries, participants, money received and comments about the SGSP.
  - ii. Contact information for all participants. This information shall be provided to the MHTC upon request or at the end of the contract period.
  - iii. Sign inventory including detailed fabrication, installation and maintenance history. The records will include at a minimum:
    1. The manufactured date of the sign (for all signs installed after the execution of this contract)
    2. The date of installation (for all signs installed after the execution of this contract)
    3. The date of notification of sign deficiencies
    4. The date the deficiency was corrected
    5. Documentation of how the deficiency was corrected
    6. An inventory of useable 'boneyard' signs and posts held for reuse
- e. Quarterly Summary: The successful Offeror shall provide the MHTC a quarterly summary of sales including, but not limited to, new contracts. A list of applicant denials and a list of contracts which expired and were not renewed shall also be included in the summary. The quarterly summary shall provide the number of participants in each program in the

SGSP. Quarterly summaries are due on July 1, October 1, January 1 and April 1 of each year.

- f. Subcontractors: The successful Offeror shall provide a list to the MHTC representative of all subcontractors who provide fabrication, erection, installation and/or maintenance of the signs if these services are not performed by the successful Offeror.
- g. Trailblazer Signs off Right of Way: If trailblazer signs for any sign program require signing to be placed off of the MHTC's right of way, the successful Offeror shall obtain the necessary permissions and permits from the local jurisdiction with authority over said roadway before installing any signs. Signing on MHTC right of way will not be allowed if the path to the site requires the placement of trailblazer signs off the state system and the successful Offeror is not able to obtain the necessary permissions and/or permits from the local jurisdiction to complete the trailblazing (ATTACHMENTS – A and B for complete program definitions and program rules).
- h. Interpretation of Sign Program Rules: Any appeal by a participant pertaining to, or request for clarification of, the sign program rules will be decided by the MoDOT State Traffic and Highway Safety Engineer or their delegated representative.

**(7) Program Fees:**

- a. Revenue Producing Programs: The required minimum payments to the MHTC shall be generated ONLY from the following programs:
  - i. TODS: shall be \$450 per sign and \$120 per trailblazer sign per year.
  - ii. Logos: shall be \$1,000 per sign per direction along highways where daily traffic count is less than 30,000 vehicles and \$1,500 per sign per direction along highways where the daily traffic count equals or exceeds 30,000 vehicles. Sign per direction under this paragraph means one mainline and one ramp sign. Traffic volume information will be provided by the MHTC.
  - iii. Traffic Generator for tourist oriented activity sites: Shall be \$2,000 per sign per direction along highways where daily traffic count is less than 30,000 vehicles and \$3,000 per sign per direction along highways where the daily traffic count equals or exceeds 30,000 vehicles. Sign per direction under this paragraph means one mainline and one ramp sign. Traffic volume information will be provided by the MHTC.

- b. Non-Revenue Producing Traffic Generators – New Participants: The agreed upon pricing for the signs paid by the applicant to the successful Offeror shall be as included on the successful Offeror’s pricing page. The required minimum payments to the MHTC shall NOT be generated from the following programs:
  - i. College Signing
  - ii. State and Federal Agency Signing
  - iii. Welcome Center Affiliate Signing
  - iv. State Correction Signing
  
- c. Non-Revenue Producing Traffic Generators – Existing MoDOT Contracts: Costs incurred by the successful Offeror for maintenance performed on existing MoDOT sign contracts will be deducted from the next quarterly fixed guaranteed payment due to the MHTC. The deduction will be calculated based on the individual components of the sign assembly which were repaired; the cost for each component repair will be at the established price on the successful Offeror’s pricing page. A detailed accounting of these costs shall be provided with the quarterly payments. The existing MoDOT sign contracts include the following programs:
  - i. Traffic Generator for Tourist Oriented Activity Sites
  - ii. College Signing
  - iii. State and Federal Agency Signing
  - iv. Welcome Center Affiliate Signing
  - v. State Correction Signing
  
- d. Additional Costs: There may be additional costs to the participants in excess of the annual fee. The costs may include such items as covering and uncovering signs for a seasonal site, fabrication of original or replacement Logo Panels, etc. As the need arises for these services, the successful Offeror shall propose the fee structure which shall be approved by the MHTC before being implemented.
  
- e. The successful Offeror may not increase fees without prior agreement by the MHTC as specified in this RFP.

Amended by Addendum 003

**(8) Contracts:** Contracts between successful Offeror and participants shall be in accordance with the following:

- a. Contract Term: The successful Offeror shall be permitted to enter into a contract with an applicant for a one year term, coinciding with the State fiscal year, which is effective July 1 and expires June 30 of the following year, after ensuring the applicant meets the program eligibility criteria as

outlined in the program rules in ATTACHMENT - A. If the applicant approaches the successful Offeror between these dates, the term of the contract will begin at the time the sign is installed and expire June 30. The contract between the participant and the successful Offeror will be binding upon execution by all parties.

- b. Contract Fee: The contract shall provide that fees are for the one year term of the contract regardless if the sign is up for the entire year or just part of the season for a seasonal site. If the contract is initiated after July 1, the fees for the contract will be prorated to reflect the time period from the date the sign is installed to the contract expiration of June 30.
- c. Contract Renewals: The successful Offeror may renew any existing contract pursuant to verifying the participant still meets the applicable program minimum eligibility criteria and the participant has fulfilled the terms of the previous year's contract in full.
- d. Contract Assignment: The contract shall provide assignment provisions in the event of termination or expiration of the contract between the successful Offeror and the MHTC.
- e. Right of Refusal: The MHTC shall have the right to reject and refuse an applicant's contract at any location, in its sole discretion, if it is determined to not be in the best interest of the MHTC.
- f. Changes in Program Eligibility: Signs which no longer qualify due to changes in roadway or intersection type will be removed by the successful Offeror. The specific contracts with the participants will be immediately cancelled with no reimbursement of fees to the participant. If the applicant qualifies for a different program at this new roadway configuration, a new contract may be executed.
- g. **Logos Program Eligibility Criteria: If logo spaces for any of the service categories mentioned in the rules remain available, then the department at its discretion, may permit other qualifying entities in the same service category meeting the majority of the criteria to utilize the otherwise unused spaces. Those qualified entities that participate, but do not fully qualify for the program, shall be reevaluated on an annual basis.**

**(9) Payment to the MHTC**

- a. TODS, Logos and Traffic Generator Signs: For the contract period of July 1, 2015 through June 30, 2020 and the optional renewal contract period of July 1, 2020 through June 30, 2025 the MHTC shall receive a fixed guaranteed payment or a guaranteed percentage of the revenues,

whichever is greater. Revenues shall be realized from the annual participation fees generated from the TODS, Logo and Traffic Generator Programs and proceeds from the sale of scrap materials. The Minimum Guaranteed Payment shall be no less than \$4,400,000, paid by the successful Offeror to the MHTC. Payments are due July 1, October 1, January 1, and April 1 of each year of the contract, in minimum equal payments of the fixed guaranteed payment, with the exception of the initial quarterly payment of the contract. The responders shall provide proposed timing of the initial quarterly payment on the pricing page.

The minimum guaranteed percentage of revenues provided by the successful Offeror to the MHTC from the participation fees and the sale of scrap materials shall be no less than 60%. If the guaranteed percent revenue is greater than the fixed guaranteed payment, the difference will be paid to the MHTC within 30 days of the audit of the successful Offeror's financial statements by a Certified Public Accountant. The audit of the financial statements shall be completed each year by September 30. Revenues are the participation fees and sales of scrap materials before any expenses associated with the program are subtracted.

- b. Cost Not Related to Program Administration: Any costs incurred by the successful Offeror due to Modification of Program Signing Due to Construction or other MoDOT Related Activities described herein, will be invoiced to the MHTC at the established price on the Pricing Page. Invoices shall be submitted to the appropriate MoDOT district representative.

**(10) Wage Laws:** The successful Offeror and its subcontractors shall pay the prevailing hourly rate of wages for each craft or type of worker required to execute this project work as determined by the Department of Labor and Industrial Relations of Missouri. The successful Offeror shall further comply in every respect with the minimum wage laws of Missouri and the United States. Federal wage rates under the Davis-Bacon or other federal acts apply to and govern this work which is performed at the jobsite, in accord with 29 CFR Part 5. Thus, this Agreement is subject to the "Contract Work Hours and Safety Standards Act", as amended (40 U.S.C. Sections 327, *et seq.*), and its implementing regulations. The successful Offeror shall take the acts which may be required to fully inform themselves of the terms of, and to comply with, state and federal laws.

**(11) Sign Ownership:** All signs, including logo panels and hardware, utilized in any of the sign programs within this contract, both within the limits of the MHTC right-of-way, as well as off of MHTC Right-of-Way, shall remain the property of the MHTC before, during and after the expiration of the contract. Sign materials may be retained by the successful Offeror to be utilized for the repair of signs in the program during the contract period. At the expiration of

the contract the usable materials remain the property of the MHTC and shall be transferred to the successful Offeror under the new contract. Any materials that cannot be used for future services will be sold for scrap by the successful Offeror, with the proceeds included in the program revenues. The MHTC reserves the right to inspect scrap materials prior to sale.

- (12) **Compliance with Laws:** The successful Offeror shall procure all required permits, Missouri One Call clearances, business licenses, in all counties of operation, insurance, bonds, and licenses; pay all charges, fees, payments, taxes and provide all notices and reports necessary and incidental to the lawful completion of the RFP requirements. Upon request, the successful Offeror shall furnish the MHTC with evidence indicating that it has complied with permit, license, tax and requirements.

Projects which include federal funding must be carried out in accordance with Federal laws and regulations. The successful Offeror shall warrant and certify that in the performance of the resultant contract it has complied with or will comply with all applicable statutes, rules, regulations and orders of the United States and the State of Missouri.

- (13) **Disputes:** Any disputes that arise under this Agreement shall be decided by the MHTC or its representative.

- (14) **Effective date and duration:** This contract shall not be binding upon the parties until it is approved by the MHTC. The contract shall be in effect for the period commencing with execution of the contract and ending on June 30, 2020. The award of this RFP permits implementation periods for the services:

- a. Upon execution of the contract, the successful Offeror shall receive notice to proceed and may, at that time, begin contacting participants and potential participants to enter into contracts effective July 1, 2015.
- b. To provide a mobilization period, the successful Offeror shall have a 62-day period, until September 1, 2015, to address non-emergency maintenance and new installations. However, issues with signs that create a safety concern for MoDOT or the traveling public shall be addressed immediately.

- (15) **Contract Renewal:** This contract shall have one (1), five (5) year renewal option, and, if executed, the contract would end on June 30, 2025. The MHTC does not automatically exercise its option for renewal, which will be determined by, but not limited to, performance, revenues and program management. If the MHTC chooses to exercise its option for renewal, the contract requirements for the renewal period shall be substantially similar to the original contract.

- (16) **Contact Amendments:** Requested amendments to the contract may include, but are not limited to, requests for increase in maintenance costs or proposals for adjustments to sign program fees. In the event the successful Offeror requests fee increases and/or other changes to the pricing page during the contract period (original contract period or contract renewal period) the successful Offeror must provide a written request and documentation justifying the need for each increase. The MHTC will utilize commodity indexes for steel, aluminum and fuel to evaluate price increases, with the commodity indexes for these materials at the time of proposal submittal serving as the benchmark. The MHTC reserves the right to review commodity indexes on an annual basis to determine if price reductions are justified. The MHTC's decision shall be final and without recourse.
- a. No price increase shall be granted during the first 3 months of the original contract period starting from the notice to proceed, or if applicable, the first 3 months of a contract period for a renewal.
  - b. The MHTC will consider only one price increase or decrease per year, *unless the MHTC implements substantial changes in standards and specifications.*
  - c. In the event a price increase is granted due to an approved escalation, the renewal percentage shall be based upon the maximum price increase/decrease the successful Offeror submits on the pricing page of this RFP.
- (17) **Early Termination:** In the event of non-performance of the terms of this contract by the successful Offeror, the revenues received from participants will be allocated over the remaining months of the current year's contracts with participants and payment shall be made to the MHTC equivalent to the prorated share of the remaining number of months in the fiscal year.

### **SECTION 3: REQUIRED ELEMENTS OF PROPOSAL AND SUBMISSION**

(A) **Required Elements of Proposal:** Each Offeror shall provide a cover letter signed by an authorized firm representative stating he/she has read and understands all of the terms and conditions of doing business with MHTC in response to this request for proposal. Each Offeror's proposal must be divided into sections corresponding to the requirements below.

1. **Experience and Performance:** Proposals shall clearly identify the Offeror's experience in providing full administrative services for the programs specifically

referenced in this RFP during a minimum of the past three (3) years. The description should include, but not be limited to:

- a. A list of the entities currently or previously served.
- b. References from current and/or past sign programs, similar to the programs defined in this RFP, which your company has managed. Include any references from State Departments of Transportation. The references should indicate the name, title and telephone number of the official(s) supplying the reference.
- c. References from applicants, subcontractors, or other sources regarding the same or similar services defined in this RFP. Include the name, title, telephone number, and category of reference.
- d. A written narrative demonstrating the method of administering the requirements of the RFP. The narrative shall include the proposed use of company employees and subcontractors and the roles of each.
- e. Qualifications of personnel who will be assigned to manage the program.

**Amended by Addendum 003**

- f. Documentation substantiating the financial stability of the successful Offeror, which may include audited financial statements or letters from financial institutions. These are considered confidential documents by the MHTC. **Six** copies should be placed in a sealed envelope clearly marked "Confidential" and must indicate in the proposal and on the outside of that envelope that confidential materials are included **This information should NOT be included in the three electronic copies required under (B) Submission of Proposals 1. Proposal Format.**

2. **Marketing.** Marketing includes, but is not limited to: printed materials available for use by prospective applicants, web based materials and resource use by prospective applicants, and active marketing to perspective applicants. Proposals shall include a comprehensive description of:
  - a. Various forms of marketing implemented successfully in current and/or past contracts similar to those defined in this RFP.
  - b. Demonstration of a comprehensive marketing plan for the programs defined in this RFP.

**Amended by Addendum 002**

3. **Reporting.** Proposals shall describe the anticipated record keeping and reporting services. ***Proposals should include but not be limited to:***
  - a. ***Quality control processes for monitoring data.***
  - b. ***Examples or mock-ups of typical status and inventory reports.***

*c. A comprehensive description of the methods used to record all requirements specifically defined in this RFP.*

**4. Program Cost and Revenue.** The Offeror is required to complete Section 6: Pricing Page of the RFP as specifically directed.

*Amended by Addendum 002*

**5. Program Implementation.** Proposals shall include a comprehensive plan on implementing the program as defined in this RFP including those signs currently managed by MoDOT's 3<sup>rd</sup> party contractor and those managed by MoDOT staff. Proposals *should* include, but not be limited to:

- a. Outreach plans to existing participants in both managed sign groups.
- b. Transition plans between old and new program administrators.

**(B) Submission of Proposals:** Offerors are responsible for submission of accurate, adequate and clear descriptions of the information requested. Omissions, vagueness or inaccurate descriptions or responses shall not be interpreted in favor of the Offeror and shall be grounds for rejection. This document is not an offer to contract, but is a RFP. Neither the issuance of the RFP, preparation and submission of a response, nor the subsequent receipt and evaluation of any response by the MHTC, will commit the MHTC to award a contract to any Offeror even if all of the requirements in the RFP are met. Only the execution of the Resulting Agreement will obligate the MHTC in accordance with the terms and conditions contained therein.

**1. Proposal Format:** The Offeror's submittal must include six (6) original hardcopy documents. Three (3) electronic copies of the proposal are desired in addition to the hardcopy document. Electronic copies of the proposal must be in Microsoft compatible format or in ".pdf" and stored on CD(s) or flash drive(s). The Offeror shall ensure the electronic copy of the proposal document stored in all media is identical to the original hardcopy response document. In case of a discrepancy, the original hardcopy proposal document language shall govern.

**2. Signatures:** Any form containing a signature line in this RFP and any amendments, pricing pages, etc., must be manually signed and returned as part of the proposal.

**3. Pricing:** The Offeror is required to specify the pricing associated with this RFP as a firm fixed price. The successful Offeror will be responsible for performing all services listed in this RFP at the prices listed on **SECTION 6: PRICING PAGE** of the RFP. MHTC will not be liable for any charges beyond those detailed in the proposal. Each Offeror is responsible for its own expense in preparing, delivering or presenting a proposal, and for subsequent oral presentations or negotiations with MHTC, if any, as provided for in this RFP.

**4. Proposal Life:** The Offerors must include a statement in the proposal that indicates the length of time during which MHTC may rely on all proposal

commitments. All proposals made in response to this RFP and quoted pricing must remain in effect for a period of not less than 90 days after the date for proposal submission. Any proposal accepted by MHTC for the purpose of contract negotiations shall remain valid until superseded by a contract or until rejected by MHTC.

- 5. Submission of All Information Required:** The Offerors must respond to this RFP by submitting all of the information required herein for its proposal to be evaluated and considered for award. Failure to submit all the required information shall be deemed sufficient cause for disqualification of a proposal from consideration.
  
- 6. Public Inspection:** The Offerors are hereby advised that all proposals and the information contained in or related thereto are subject to Missouri Open Records Act and after contract award and execution of the Resulting Agreement shall be open to public inspection and may be viewed and copied by any member of the public; therefore, MHTC does not assume any responsibility whatsoever in the event that such information is used or copied by individual persons or organizations.
  - a. Offerors claiming a statutory exception to the Missouri Open Records Act must place all confidential documents (including the requisite number of copies) in a sealed envelope clearly marked “Confidential” and must indicate in the proposal and on the outside of that envelope that confidential materials are included. The Offeror must also specify which statutory exception provision applies. MHTC reserves the right to make determinations of confidentiality. If MHTC does not agree that the information designated is confidential under one of the disclosure exceptions to the Missouri Open Records Act, it may either reject the proposal or discuss its interpretation of the allowable exceptions with the Offeror. If agreement can be reached, the proposal will be considered. If agreement cannot be reached, MHTC will remove the proposal from consideration for award and return the proposal to the Offeror.
  - b. MHTC will not consider prices to be confidential information.
  - c. MHTC will consider documentation substantiating the financial stability of the successful Offeror, which may include audited financial statements or letters from financial institutions, to be confidential information.
  - d. The Offeror must submit its proposal based on the conditions contained in this paragraph without reservations.
  
- 7. Pre-proposal Conference (not required):** A pre-proposal conference will be held on April 7, 2015, 1:00 – 4:00 p.m. CST in the Gold Conference Room, 830 MoDOT Drive, Jefferson City, MO 65109. Information relating to this RFP will be discussed in detail so all potential Offerors are encouraged to attend this

conference This RFP will be used as the agenda for the pre-proposal conference therefore Offerors should bring a copy of the RFP. The MHTC/MoDOT shall not reimburse vendors for the costs of attending the pre-proposal conference.

8. **Clarification of Requirements:** It shall be the Offeror's responsibility to ask questions, request changes or clarification, or otherwise advise MHTC/MoDOT if any language, specifications or requirements of the RFP appear to be ambiguous, contradictory, and/or arbitrary, or appear to inadvertently restrict or limit the requirements stated in the RFP to a single source.
  - a. Any and all communication from Offerors regarding specifications, requirements, competitive proposal, etc., must be directed to the RFP Buyer of Record listed herein, unless the RFP specifically refers the Offerors to another contact. Such communication shall be received by the date noted in **SECTION 1: GENERAL DESCRIPTION AND BACKGROUND, (D) Schedule of Events.**
  - b. Every attempt will be made to ensure that the Offeror receives an adequate and prompt response. However, in order to maintain a fair and equitable proposal process, all Offerors will be advised, via the issuance of an amendment to the RFP, of any relevant or pertinent information related to the procurement. Therefore, Offerors are advised that unless specified elsewhere in the RFP, any questions received after the listed date may not be answered.
9. **Oral Presentation:** After an initial screening of the written proposals, any, or all of the Offerors submitting a proposal in response to this RFP may be required to give an oral presentation of their proposal. Additional technical information may be requested for clarification purposes, but in no way to change the original written proposal submitted. MHTC reserves the right, in its sole discretion, to decide to conduct oral presentations with any or all of the Offerors. If an oral presentation is conducted, it is preferred that the Offeror's personnel to be assigned to the work, as well as key representatives, be present at and participate in the oral presentation.
10. **Official Position of MHTC:** Offerors are cautioned that the only official position of the MHTC and MoDOT is that which is issued by MHTC in the RFP or an amendment thereto. No other means of communication, whether oral or written, shall be construed as a formal or official response or statement.

#### **SECTION 4: EVALUATION FACTORS AND PROCESS:**

- (A) **Evaluation Factors:** The following factors shall be considered in the evaluation of the proposals:



The Offeror with the greatest net revenue will receive the full (13) points for this subcategory. *All other offerors will receive allocated points based upon the revenue submitted compared to the greatest net revenue.*

Amended by Addendum 003 and 004

- b. The Impact to Participants will be calculated based on the proposed pricing provided in Section 6: Pricing Sections 3, 4, 5, and 6 using the annual estimated units supplied.

$$\text{IMPACT TO PARTICIPANTS} = \frac{\text{CONSTRUCTION AND MATERIAL COSTS}}{\pm} \text{NEW INSTALLATION FEES FOR ATTACHMENT - G} + \text{NEW INSTALLATION FEES FOR ATTACHMENT - F} + \text{ANNUAL RENEWAL FEES}$$

The Offer with the lowest cost to applicants will receive the full (2) points for this subcategory. *All other offerors will receive allocated points based upon the revenue submitted compared to the greatest net revenue.*

- 2. **Historical Information:** MHTC reserves the right to consider historical information and facts, whether gained from the Offeror's proposal, presentations or interviews as applicable, references, or other sources, including but not limited to the listed subcontractors, in the evaluation process.
- 3. **Responsibility to Submit Information:** Each Offeror is cautioned that it is the Offeror's sole responsibility to submit information related to the evaluation criteria and MHTC is under no obligation to solicit such information if it is not included with the Offeror's proposal. Failure of the Offeror to submit such information may cause an adverse impact on the evaluation of the Offeror's proposal.

(B) **Proposal Review/Evaluation:** MHTC will select a group of individuals to comprise the proposal review team.

## SECTION 5: TERMS AND CONDITIONS

(A) **Agreement Components:** The Resulting Agreement between MHTC and the successful Offeror shall incorporate by reference as its components the following: the RFP and any written amendments thereto and the proposal submitted by the successful Offeror in response to the RFP. In case of a conflict between or inconsistency in the terms contained in the RFP and the proposal submitted by the Offeror in response to the RFP, the terms of the RFP shall govern. In the event of a conflict between or inconsistency in the terms of the RFP and the Resulting Agreement, the terms of the Resulting Agreement shall govern. MHTC reserves the right, in its sole discretion, to clarify any relationship in writing and such written clarification

shall govern in case of any conflict with or inconsistency in the applicable requirements stated in the RFP and the successful Offeror's proposal.

**(B) MHTC's Representative:** MoDOT's State Traffic and Highway Safety Engineer is designated as MHTC's representative with authority to act on behalf of MHTC for the purpose of administering the Resulting Agreement. MHTC's representative may designate by written notice other persons having the authority to act on behalf of MHTC in furtherance of the performance of the Resulting Agreement. Each Offeror shall fully coordinate its activities with the designated representative and shall consult the MHTC representative regarding any problem arising out of the provision of the services to the MHTC pursuant to this RFP and the Resulting Agreement. As the work of the successful Offeror progresses, advice and information on matters covered by the Resulting Agreement shall be made available by the successful Offeror to the designated representative throughout the effective period of the Agreement. MHTC reserves the right to limit the authority of Buyer of Record and MHTC's representative provided herein as it deems necessary in its sole discretion at any time and from time to time throughout the duration of the RFP process and the Contract Period.

**(C) Assignment:** The successful Offeror shall not assign, transfer, or delegate any interest in the services to be provided under this RFP and the Resulting Agreement without the prior written consent of the MHTC representative. The successful Offeror may at its own expense employ clerical or technical assistance in the performance of the services under this RFP and the Resulting Agreement, such clerical and technical assistance provider being as fully bound as the Offeror to all confidentiality and work product provisions of this RFP and the Resulting Agreement.

**(D) Amendments:** Any change in the Resulting Agreement, whether by modification or supplementation, must be accompanied by a formal contract amendment signed and approved by the duly authorized representative of the successful Offeror and MHTC.

**(E) Disputes Under the RFP and Resulting Agreement:** The MHTC representative and/or Buyer of Record, as applicable, will decide all questions which may arise as to the quality, quantity, and acceptability of any Offeror's proposals submitted in response to this RFP, and of the services under this RFP and the Resulting Agreement performed by the successful Offeror and as to the rate of progress of the services; all questions which may arise as to the interpretation of the services to be performed under this RFP and the Resulting Agreement; all questions as to the acceptable fulfillment of the Resulting Agreement on the part of the successful Offeror; the proper compensation for performance or breach of the Resulting Agreement; and all claims of any character whatsoever in connection with or growing out of the services to be performed or performed by the successful Offeror, whether claims under this RFP and the Resulting Agreement or otherwise. The decision of the MHTC representative and/or Buyer of Record, as applicable, shall be conclusive, binding, and incontestable.

**(F) Successors and Assigns:** The MHTC and the Offerors agree that this RFP and, as applicable, the Resulting Agreement as well as all agreements entered into under the provisions of this RFP, shall be binding upon the parties thereto and their successors and assigns.

**(G) Sole Beneficiary:** The Resulting Agreement will be made for the sole benefit of the parties thereto and nothing in this RFP or the Resulting Agreement shall be construed to give any rights or benefits to anyone other than the MHTC and the successful Offeror.

**(H) Cancellation of Resulting Agreement:** MHTC may cancel the Resulting Agreement at any time by providing the successful Offeror with a written notice of cancellation. Should the MHTC exercise its right to cancel the Resulting Agreement, cancellation will become effective upon the date specified in the notice of cancellation.

**(I) Bankruptcy:** Upon filing for any bankruptcy or insolvency proceeding by or against any Offeror or assignee, whether voluntarily, or upon the appointment of a receiver for the benefit of creditors, MHTC reserves the right and sole discretion to reject the Offeror's proposal, or, as applicable, either cancel the Resulting Agreement or affirm the Resulting Agreement and hold the successful Offeror responsible for damages.

**(J) Status as Independent Contractor:** The successful Offeror represents itself to be an independent contractor offering such services to the general public and shall not represent itself or its employees to be an employee of MHTC or MoDOT. Therefore, the successful Offeror shall assume all legal and financial responsibility for taxes, FICA, employee fringe benefits, workers' compensation, employee insurance, minimum wage requirements, overtime, or other such benefits or obligations.

**(K) Subcontractor:** Any Offeror's proposal must identify all subcontractors, if any, and outline the contractual relationship between the Offeror and each subcontractor. Either a copy of the executed subcontract or a letter of agreement over the official signature of the firms involved must accompany each proposal. MHTC must approve the successful Offeror's subcontracting any portion of the services to be provided under the Agreement. The successful Offeror is responsible for the performance of any obligations that may result from this RFP and the Agreement and shall not be relieved by the non-performance of any subcontractor.

**(L) MBE/WBE Participation Encouraged:**

**1. Affirmative Action Program:** Offerors are encouraged to submit copies of their existing affirmative action programs, if any. Offerors are also encouraged to directly hire minorities and women as direct employees of the Offerors.

**2. Minority Participation Encouraged:** Offerors are encouraged to obtain minority business enterprise (MBE) and women business enterprise (WBE) participation in this work through the use of subcontractors, suppliers, joint ventures, or other arrangements that afford meaningful participation for M/WBEs (i.e. 10% MBE and 5% WBE participation).

**3. Offeror's Responsibility Unconditional:** Regardless of which persons or firms, if any, that the successful Offeror may use as subcontractors or suppliers of goods or services for the services to be provided, the successful Offeror ultimately remains responsible and liable to MHTC for the complete, accurate, and professional quality/performance of these services.

**(M) Nondiscrimination:** The Offerors shall comply with all state and federal statutes applicable to the Offerors relating to nondiscrimination, including, but not limited to, Chapter 213, RSMo; Title VI and Title VII of Civil Rights Act of 1964 as amended (42 U.S.C. Sections 2000d and 2000e, *et seq.*); and with any provision of the “Americans with Disabilities Act” (42 U.S.C. Section 12101, *et seq.*).

**(N) Executive Order:** The Offerors shall comply with all the provisions of Executive Order 07-13, issued by the Honorable Matt Blunt, Governor of Missouri, on the sixth (6<sup>th</sup>) day of March, 2007. This Executive Order, which promulgates the State of Missouri’s position to not tolerate persons who contract with the state engaging in or supporting illegal activities of employing individuals who are not eligible to work in the United States, is incorporated herein by reference and made a part of this Agreement.

**1. Offeror’s Certification:** By signing the proposal to this RFP, the Offeror hereby certifies that any employee of the Offeror assigned to perform services herein is eligible and authorized to work in the United States in compliance with federal law.

**2. Failure to Comply:** In the event the Offeror fails to comply with the provisions of the Executive Order 07-13, or in the event the MHTC has reasonable cause to believe that the Offeror has knowingly employed individuals who are not eligible to work in the United States in violation of federal law, the MHTC reserves the right to reject the Offeror’s proposal or, as applicable, impose such contract sanctions as it may determine to be appropriate, including but not limited to contract cancellation, termination or suspension in whole or in part or both.

**3. Incorporation of Provisions:** The successful Offeror shall include the provisions of this paragraph in every subcontract. The successful Offeror shall take such action with respect to any subcontract as the MHTC may direct as a means of enforcing such provisions, including sanctions for noncompliance.

**(O) Non-employment of Unauthorized Aliens:** Pursuant to Section 285.530, RSMo., no business entity or employer shall knowingly employ, hire for employment, or continue to employ an unauthorized alien to perform work within the State of Missouri. As a condition for the award of any contract or grant in excess of five thousand dollars by the State or by any political subdivision of the State to any Offeror, or for any Offeror receiving a state-administered or subsidized tax credit, tax abatement, or loan from the state, the Offeror shall:

**1. Enrollment in Federal Work Authorization Program:** By sworn affidavit and provision of documentation, affirm its enrollment and participation in a federal work authorization program with respect to the employees working in connection with the contracted services. E-Verify is an example of a federal work authorization program. The Offeror must affirm its enrollment and participation in the E-Verify federal work authorization program with respect to the employees proposed to work in connection with the services requested herein by providing acceptable enrollment and participation documentation consisting of completed copy of the E-Verify Memorandum of Understanding (**MOU**). For Offerors that

are not already enrolled and participating in a federal work authorization program, E-Verify is available at [http://www.dhs.gov/xprevprot/programs/gc\\_1185221678150.shtm](http://www.dhs.gov/xprevprot/programs/gc_1185221678150.shtm).

**2. Annual Worker Eligibility Affidavit:** By sworn affidavit, affirm that it does not knowingly employ any person who is an unauthorized alien in connection with the contracted services. Offerors are required to complete and submit with their proposal the affidavit referenced herein, which is provided within this document and attached as **Exhibit 1**.

**(P) Proof of Lawful Presence For Sole Proprietorships and Partnerships:** If the Offeror is a sole proprietorship or partnership, pursuant to Section 208.009, RSMo., each sole proprietor and each general partner shall provide affirmative proof of lawful presence in the United States. Such sole proprietorship or partnership is eligible for temporary public benefits upon submission by each sole proprietor and general partner of a sworn affidavit of his/her lawful presence on the United States until such lawful presence is affirmatively determined, or as otherwise provided by Section 208.009, RSMo. As applicable, Offerors are required to complete and submit with their proposals the copy of the affidavit referenced herein, which is provided within this document and attached as **Exhibit 2**.

**(Q) Offeror Requirements:** Offerors must comply with the following requirements to do business in Missouri:

**1. Registration with Secretary of State:** The Offerors must be registered and maintain good standing with the Secretary of State of the State of Missouri, Missouri Department of Revenue, and other regulatory agencies, as may be required by law or regulations. Prior to execution of the Resulting Agreement, the successful Offeror shall submit to MHTC a copy of its current Authority Certificate from the Secretary of State of the State of Missouri and/or a copy of its Certificate of No Tax Due from the Missouri Department of Revenue.

**2. Transient Employer Certificate:** All out-of-state Offerors providing services within the State of Missouri must provide a copy of their current Transient Employer Certificate issued from the Missouri Department of Revenue. For assistance with obtaining a Transient Employer Certificate, please call the Missouri Department of Revenue at (573) 751-0459.

**(R) Law of Missouri to Govern:** This RFP and the Resulting Agreement shall be construed according to the laws of the State of Missouri. The Offeror shall comply with all local, state, and federal laws and regulations relating to this RFP and, if applicable, the performance of the Agreement.

**(S) Venue:** It is agreed by the parties that any action at law, suit in equity, or other judicial proceeding to enforce or construe this Agreement, or regarding its alleged breach, shall be instituted only in the Circuit Court of Cole County, Missouri.

**(T) Ownership of Records:** All documents, reports, exhibits, etc., produced by the Offerors at the direction of MHTC's representative and information supplied by MHTC's

representative shall remain the property of MHTC.

**(U) Release to Public/Confidentiality:** No material or reports prepared by the successful Offeror shall be released to the public without the prior consent of MHTC's representative. The Offerors shall not disclose to third parties confidential factual matters provided by MHTC's representative except as may be required by statute, ordinance, or order of court, or as authorized by MHTC's representative. The Offerors shall notify MHTC immediately of any request for such information.

**(V) Prohibition Against Kickbacks and Gratuities/Nonsolicitation:** Any kickback, gratuity, or other payment by the Offeror to any person employed by or on behalf of the MHTC is prohibited except when such payment is made pursuant to the express terms of this RFP and, as applicable, the Resulting Agreement. Each Offeror warrants that it has not employed or retained any company or person, other than a bonafide employee working for the Offeror, to solicit or secure this RFP and as applicable the Resulting Agreement, and that the Offeror has not paid or agreed to pay any company or person, other than a bonafide employee, a fee, commissions, percentage, brokerage fee, gift, or other consideration, which is contingent upon or Resulting from the award of this RFP and, as applicable, the Resulting Agreement. For breach or violation of this warranty, the MHTC shall have the right to reject the Offeror's proposal and, as applicable, annul the Resulting Agreement without liability, or in its discretion, to withhold or recover said amounts from the compensation due or paid under the Resulting Agreement.

**(W) Conflict of Interest:** Each Offeror covenants that it presently has no actual conflict of interest or appearance of conflict of interest and shall not acquire any interest, directly or indirectly, which would conflict in any manner or degree with the performance of the services under this Agreement. The Offeror further covenants that no person having any such known interest shall be employed or conveyed an interest, directly or indirectly, in this RFP and the Resulting Agreement.

**(X) Audit of Records:** The successful Offeror must maintain all working papers and records relating to the Agreement. These records must be made available at all reasonable times at no charge to MHTC and/or the Missouri State Auditor during the term of the Agreement and any extension thereof, and for three (3) years from the date of final payment made under the Agreement. MHTC's representative shall have the right to reproduce and/or use any products derived from the successful Offeror's work without payment of any royalties, fees, etc. MHTC's representative shall at all times have the right to audit any and all records pertaining to the services.

**(Y) Indemnification:** Each Offeror shall defend, indemnify, and hold harmless the MHTC, including its members and department employees, from any claim or liability whether based on a claim for damages to real or personal property or to a person for any matter relating to or arising out of the Offeror's submittal of its proposal in response to the RFP, performance of its obligations under this RFP and, as applicable, the Agreement.

*Amended by Addendums 002  
and 003*

**(Z) Bonding:**

*Proposal Guaranty: Each proposal shall be accompanied by a certified check, cashier's check or bank money order on any bank or trust company insured by the Federal Deposit Insurance Corporation, payable to the Director of Revenue – Credit State Road Fund for an amount equal to three hundred seventy thousand dollars (\$370,000), five percent (5%) of the amount of the contract. This is to act as a guarantee that the Offeror, if awarded the contract, will furnish an acceptable Contract Bond.*

*If a Proposal Bond is used, it must be in the form provided and executed by the Offeror as principal and by a surety company authorized to do business in the State of Missouri as surety. The agent executing the same on behalf of the surety company must attach a current Power of Attorney setting forth his authority to execute the bond involved.*

*Certified checks, cashier's checks or bank money orders of unsuccessful proposers will be returned as soon as the contract is executed with the successful Offeror. The checks or bank money orders of the successful Offeror will be retained until a satisfactory Contract Bond is furnished. Proposal Bonds will not be returned except on specific request of the Offeror.*

**The proposal bond shall be included with one of the original copies required in Section 3 (B) Submission of Proposals 1. Proposal Format.**

*Failure to execute the contract and file acceptable Contract Bond within 15 days after the contract has been mailed to the successful Offeror shall be just cause for the cancellation of the award and the forfeiture of the proposal guaranty. No contract shall be considered effective until it has been executed by all parties thereto.*

**Contract Bond:** For all the work to be performed by the Successful Offeror under this agreement the Successful Offeror shall, at the time of the execution of this Agreement, furnish a contract bond in a sum equal to the *fiscal year 2014 revenue, seven million four hundred thousand dollars (\$7,400,000)*. The bond shall be to the State of Missouri, in the form provided by the Commission and with surety or sureties acceptable to the Commission, to ensure the proper and prompt completion of the work in accordance with the provisions of the Agreement, the Successful Offeror's compliance with all of the terms and conditions of the Agreement, all obligations on the Successful Offeror's part to be performed and payment of all obligations to the Commission by the Successful Offeror, including any indebtedness, liquidated or unliquidated, for any reason relating to or arising from the Agreement, and to ensure payment for all labor performed and material consumed or used in the work. The bond, *if executed by a surety that is a corporation organized in a state other than Missouri*, shall be signed by an agent or broker licensed by the Missouri Department of Insurance. The surety's liability under the contract bond and this Agreement shall not be limited to the penal sum as set forth in the contract bond. The surety shall be liable and responsible to the Commission for the successful Offeror's entire performance and of all obligations arising under or from the contract, which shall include, but is not limited to any change orders issued under the contract that increase the cost of the contract.

*A surety will be acceptable to the Commission if the surety is listed in the current United States Department of the Treasury, Fiscal Service, Department Circular 570, Companies Holding Certificates of Authority as Acceptable Sureties on Federal Bonds and as Acceptable Reinsuring Companies. Individual contract bonds may not be in excess of the underwriting limitation listed in the circular*

**(AA) Insurance:** The successful Offeror shall carry commercial general liability insurance and commercial automobile liability insurance from a company authorized to issue insurance in Missouri, and to name the Commission, and the Missouri Department of Transportation and its employees, as additional named insureds in amounts sufficient to cover the sovereign immunity limits for Missouri public entities (\$500,000 per claimant and \$3,000,000 per occurrence) as calculated by the Missouri Department of Insurance, Financial Institutions and Professional Registration, and published annually in the Missouri Register pursuant to Section 537.610, RSMo. The successful Offeror must provide original certificates of insurance at the time of execution of the contract. The successful Offeror's insurance coverage shall be for not less than the following limits of liability:

1. Commercial General Liability: \$500,000 per person up to \$3,000,000 per occurrence;
2. Automobile Liability: \$500,000 per person up to \$3,000,000 per occurrence; and
3. Worker's Compensation: In accordance with the statutory limits; and Employer's Liability: \$1,000,000.

**(BB) Section Headings:** All section headings contained in this RFP and the Resulting Agreement are for the convenience of reference only and are not intended to define or limit the scope of any provision of this RFP and the Resulting Agreement.

**(CC) Severability:** If any clause or provision of this RFP and/or the Resulting Agreement is found to be void or unenforceable by a court or agency of proper jurisdiction, then the remaining provisions not void or unenforceable shall remain in full force and effect.

**(DD) No Adverse Inference:** This RFP and/or the Resulting Agreement shall not be construed more strongly against one party or the other. No rule of construction which requires that any allegedly ambiguous provision be interpreted more strongly against one party than the other shall be used in interpreting this RFP and/or the Resulting Agreement.

**SECTION 6:  
PRICING PAGE**

*Amended by Addendum 002 and 004*

The Offeror shall provide a guaranteed, not to exceed, total price for each of the following items listed in each of the following pricing categories. The estimated quantities listed in each table are only estimates and are not guaranteed.

1. Payments to the MHTC: The successful Offeror shall provide their proposed pricing below for the proposed annual payments to the MHTC. The annual payments to the MHTC are expected to be a minimum of \$4.4 million dollars (\$4,400,000) a year or a minimum of 60% of the program revenues, whichever is greater. All fields shall be completed in the table below. ***The total of the greater of the guaranteed minimum fixed annual payment to the MHTC over the 5 years and the guaranteed minimum percent revenue payment to the MHTC over the 5 years, using FY 2014 revenue (\$7,416,806) from Attachment L will be used in the calculation exhibited in Section 4, Evaluation Factors and Process, (A) Evaluation Factors 1. Evaluation Criteria..***

PAYMENT TYPE	Year 1	Year 2	Year 3	Year 4	Year 5
GUARANTEED MINIMUM FIXED ANNUAL PAYMENT TO THE MHTC	\$	\$	\$	\$	\$
GUARANTEED MINIMUM PERCENT OF REVENUE PAYMENT TO THE MHTC	%	%	%	%	%

2. Proposal for The Initial Payment to the MHTC: The successful Offeror shall provide their proposal, including date and proposed payment, for making the initial ***quarterly*** payment to the MHTC. If the successful Offeror plans to make the initial ***quarterly*** payment on July 1, 2015, that shall also be indicated below. ***Under Section 2, Scope of Work and Specific Services, (B) Specific Services, (9) Payment to the MHTC provides payments after the initial payment are in minimum equal payments of the fixed guaranteed payment, with the responder providing the proposed timing of the initial quarterly payment.***

(LIST PROPOSAL HERE OR ATTACH PROPOSAL TO SUBMITTAL DOCUMENT)

3. Construction and Maintenance Costs for Existing MoDOT Signs: The successful Offeror shall provide their proposed pricing below for *signs modified due to MoDOT construction and / or* maintenance of existing *Traffic Generator signs currently under contract with the MHTC*. As MoDOT contracts expire over the next 10 years, participants will transition to participation agreements under this contract and these estimated quantities will decrease. Invoices submitted to the MHTC shall be expressed in the terms of the pricing schedule below. The estimated quantities are only estimates and not guaranteed.

ITEM	ITEM TYPE	ANNUAL ESTIMATED UNITS	UNIT	UNIT PRICE	TABULATION
LABOR/EQUIPMENT	INSTALLATION	620	SQFT	\$	\$
NEW SIGN PANEL	STRUCTURAL	300	SQFT	\$	\$
NEW SIGN PANEL	FLAT SHEET	120	SQFT	\$	\$
OVERLAY	STRUCTURAL SIGNS ONLY	200	SQFT	\$	\$
SIGN POST & STUB	STRUCTURAL STEEL I-BEAM	400	POUND	\$	\$
SIGN POST & STUB	PIPE POST	120	POUND	\$	\$
SIGN POST & STUB	PSST	200	POUND	\$	\$
SIGN POST FOOTING	PSST - CONCRETE	10	EACH	\$	\$
SIGN POST FOOTING	PIPE POST	2	EACH	\$	\$
SIGN POST FOOTING	TYPE I	10	EACH	\$	\$
SIGN POST FOOTING	TYPE II	10	EACH	\$	\$
SIGN POST FOOTING	TYPE III	8	EACH	\$	\$
SIGN POST FOOTING	TYPE IV	8	EACH	\$	\$
SIGN POST FOOTING	TYPE V	4	EACH	\$	\$
SIGN POST FOOTING	TYPE VI	2	EACH	\$	\$
<b>TOTAL</b>					<b>\$</b>

4. Contract Fees for New Sign Installations – Reference ATTACHMENT - G: The successful Offeror shall provide their proposed pricing below for sign installations for new contracts with State and Federal Agencies. The successful Offeror shall understand and agree, the unit price represents the entire cost to install the sign including, but not limited to, sign, posts, footing, labor and equipment, profit and overhead.

SIGN TYPE	SIGN SIZE (FEET)	SUBSTRATE	ANNUAL ESTIMATED UNITS	UNIT	UNIT PRICE	TABULATION
STATE PARK MAINLINE FREEWAY	13 X 9	EXTRUDED ALUMINUM PANEL	4	EACH	\$	\$
STATE PARK MAINLINE FREEWAY OR EXPRESSWAY	11 X 5	EXTRUDED ALUMINUM PANEL	10	EACH	\$	\$
STATE HISTORIC SITE MAINLINE FREEWAY	13 X 11	EXTRUDED ALUMINUM PANEL	2	EACH	\$	\$
STATE HISTORIC SITE MAINLINE FREEWAY OR EXPRESSWAY	11 X 6	EXTRUDED ALUMINUM PANEL	4	EACH	\$	\$
STATE PARK AND HISTORIC SITE MAINLINE FREEWAY	13 X 12	EXTRUDED ALUMINUM PANEL	2	EACH	\$	\$
STATE PARK AND HISTORIC SITE MAINLINE FREEWAY OR EXPRESSWAY	11 X 7	EXTRUDED ALUMINUM PANEL	2	EACH	\$	\$
CONSERVATION AREA MAINLINE FREEWAY	13 X 11	EXTRUDED ALUMINUM PANEL	6	EACH	\$	\$
CONSERVATION AREA MAINLINE FREEWAY OR EXPRESSWAY	11 X 6	EXTRUDED ALUMINUM PANEL	8	EACH	\$	\$
STATE OR FEDERAL AGENCY RAMP / TRAILBLAZER	6 X 2	EXTRUDED ALUMINUM PANEL	20	EACH	\$	\$
STATE OR FEDERAL AGENCY RAMP / TRAILBLAZER	7 X 2	EXTRUDED ALUMINUM PANEL	36	EACH	\$	\$
STATE OR FEDERAL AGENCY RAMP / TRAILBLAZER	3 X 4	FLAT SHEET ALUMINUM	2	EACH	\$	\$
FEDERAL AGENCY SITE MAINLINE FREEWAY (approximate size 10' x 6')	VAR X VAR	EXTRUDED ALUMINUM PANEL	120	SQUARE FOOT	\$	\$
					<b>TOTAL</b>	<b>\$</b>

5. Contract Fees for New Sign Installations – Reference ATTACHMENT - F: The successful Offeror shall provide their proposed pricing below for sign installations for new contracts with Colleges, Welcome Center Affiliates and State Correctional Centers. The successful Offeror shall understand and agree, the unit price represents the entire cost

to install the sign including, but not limited to, sign, posts, footing, labor and equipment, and profit and overhead. Pricing for College Emblem signing will be applied in a similar manner as Logos, with the fee representing the display on the mainline and ramp emblem signs for one direction. Given multiple schools share a common sign, no one school should bear the entire, initial cost to install the emblem sign.

SIGN TYPE	SIGN SIZE (FEET)	SUBSTRATE	ANNUAL ESTIMATED UNITS	UNIT	UNIT PRICE	TABULATION
COLLEGE GENERATOR MAINLINE FREEWAY (approximate size 10' x 8')	VAR X VAR	EXTRUDED ALUMINUM PANEL	320	SQUARE FOOT	\$	\$
COLLEGE GENERATOR RAMP/TRAILBLAZER (approximate size 8' x 3')	VAR X VAR	EXTRUDED ALUMINUM PANEL	96	SQUARE FOOT	\$	\$
COLLEGE EMBLEM FREEWAY (RAMP AND MAINLINE)	VAR X VAR	EXTRUDED ALUMINUM PANEL	6	ONE EXIT DIRECTION	\$	\$
COLLEGE EMBLEM TRAILBLAZER	1.5 X 1.5	FLAT SHEET ALUMINUM	6	EACH	\$	\$
WELCOME CENTER AFFILIATE MAINLINE FREEWAY	10 X 7	EXTRUDED ALUMINUM PANEL	2	EACH	\$	\$
WELCOME CENTER AFFILIATE RAMP / TRAILBLAZER	3 X 4	FLAT SHEET ALUMINUM	2	EACH	\$	\$
STATE CORRECTIONAL CENTER MAINLINE FREEWAY (approximate size 10' x 8')	VAR X VAR	EXTRUDED ALUMINUM PANEL	160	SQUARE FOOT	\$	\$
STATE CORRECTIONAL CENTER RAMP / TRAILBLAZER (approximate size 8' x 3')	VAR X VAR	EXTRUDED ALUMINUM PANEL	48	SQUARE FOOT	\$	\$
					<b>TOTAL</b>	<b>\$</b>

6. Annual Renewal Fees: The successful Offeror shall provide their proposed pricing below for the annual renewal fees applicable for all Traffic Generator signing programs within this RFP (these fees DO NOT apply to TODS, Logos or Traffic Generator signing for tourist oriented activity sites). Once an applicant enters into a contract with the successful Offeror and the initial sign installation is paid, the annual renewal fee schedule below shall represent the fees charged to a participant at the renewal period of their

contract. **The estimated quantities shown represent of all signs currently under contract with the MHTC currently. The successful Offeror will not realize full revenue from annual renewals for 10 years, when the last MHTC contract has expired.**

ITEM	PROGRAM ESTIMATED UNITS	UNIT	UNIT PRICE	TABULATION
COLLEGE EMBLEM - RAMP, MAINLINE & TRAILBLAZER COMBINED	140	ONE EXIT DIRECTION	\$	\$
MAINLINE EXTRUDED PANEL SIGNS (assumed average size = 10' x 10')	51,000	SQFT		
RAMP / TRAILBLAZER EXTRUDED PANEL SIGNS (assumed average size = 7' x 2')	14,000	SQFT	\$	\$
ALL OTHER FLAT SHEET SIGNS	1,000	SQFT	\$	\$
			<b>TOTAL</b>	<b>\$</b>

7. Annual Price Increase / Decrease: The successful Offeror shall provide their proposed maximum annual percent increase and decrease which may be applied to all cost and fee items included in sections 3, 4, 5 and 6 of this pricing page. This price increase/decrease SHALL NOT affect the Payments to the MHTC the successful Offeror submits in this RFP.

MAXIMUM ANNUAL PERCENT INCREASE	%
MAXIMUM ANNUAL PERCENT DECREASE	%

Offeror Printed or Typed Name: \_\_\_\_\_

Mailing Address: \_\_\_\_\_

City: \_\_\_\_\_ State: \_\_\_\_\_ Zip: \_\_\_\_\_



**EXHIBIT 2**

**APPLICANT AFFIDAVIT FOR SOLE-PROPRIETORSHIP OR PARTNERSHIP**

(a separate affidavit is required for each owner and general partner)

STATE OF \_\_\_\_\_ )  
 ) ss  
COUNTY OF \_\_\_\_\_ )

On this \_\_\_\_\_ day of \_\_\_\_\_, 20\_\_\_\_, before me appeared \_\_\_\_\_, personally known to me or proved to me on the basis of satisfactory evidence to be the person whose name is subscribed to the within instruments, who being by me duly sworn, deposed as follows:

My name is \_\_\_\_\_, and I am of sound mind, capable of making this affidavit, and personally certify the facts herein stated, as required by Section 208.009, RSMo, for failure to provide affirmative proof of lawful presence in the United States of America:

I am the \_\_\_\_\_ of \_\_\_\_\_, which is applying for a public benefit (grant, contract, and/or loan) administered/provided by the Missouri Highways and Transportation Commission (MHTC), acting by and through the Missouri Department of Transportation (MoDOT).

I am classified by the United States of America as: (check the applicable box)

- a United States citizen.
- an alien lawfully admitted for permanent residence. I am aware that Missouri law provides that any person who obtains any public benefit by means of a willfully false statement or representation, or by willful concealment or failure to report any fact or event required to be reported, or by other fraudulent device, shall be guilty of the crime of stealing pursuant to Section 570.030, RSMo, which is a Class C felony for stolen public benefits valued between \$500 and \$25,000 (punishable by a term of imprisonment not to exceed 7 years and/or a fine not more than \$5,000 – Sections 558.011 and 560.011, RSMo), and is a Class B felony for stolen public benefits valued at \$25,000 or more (punishable by a term of imprisonment not less than 5 years and not to exceed 15 years – Section 558.011, RSMo).

I recognize that, upon proper submission of this sworn affidavit, I will only be eligible for temporary public benefits until such time as my lawful presence in the United States is determined, or as otherwise provided by Section 208.009, RSMo.

I understand that Missouri law requires MHTC/MoDOT to provide assistance in obtaining appropriate documentation to prove citizenship or lawful presence in the United States, and I agree to submit any requests for such assistance to MHTC/MoDOT in writing.

I acknowledge that I am signing this affidavit as a free act and deed and not under duress.

\_\_\_\_\_  
Affiant Signature

\_\_\_\_\_  
Affiant's Social Security Number or  
Applicable Federal Identification Number

Subscribed and sworn to before me this \_\_\_\_\_ day of \_\_\_\_\_, 20\_\_\_\_\_.

\_\_\_\_\_  
Notary Public

My commission expires:

**EXHIBIT 3**

**CONTRACT BOND  
SUPPLEMENTAL GUIDE SIGN PROGRAM  
RFP #6-150504DR**

**KNOW ALL MEN BY THESE PRESENTS:** That we \_\_\_\_\_

\_\_\_\_\_ as principle, and \_\_\_\_\_

as surety, are held and firmly bound unto the State of Missouri in the penal sum of: \_\_\_\_\_

\_\_\_\_\_ DOLLARS (\$ \_\_\_\_\_ ) as the same may be increased by any and all changes in or additions to said contract which may hereafter be made, lawful money of the United States, to be paid to the said State of Missouri or to its certain agents, attorneys, assigns, or to the Missouri Highways and Transportation Commission, for which sums of money, well and truly to be paid, we bind ourselves, our heirs, successors, assigns, executors, and administrators, jointly and severally, firmly by these presents.

**SEALED** with our seals and dated \_\_\_\_\_

The condition of this obligation is such that

**WHEREAS**, the said bounden principal has entered into a certain contract with the State of Missouri acting by and through the Missouri Highways and Transportation Commission, said contract being marked.

:  
..

a copy of said contract being hereto attached and made a part hereof and bearing date of \_\_\_\_\_

**NOW, THEREFORE**, if the said principal shall comply with and fulfill all the conditions of said contract, including those under which principal agrees to pay the prevailing hourly rate of wages for each craft or type of workman required to execute the contract in the locality as determined by State and Federal authority, as applicable, or by final judicial determination, and properly and promptly complete the work in accordance with the provisions of said contract, plans and specifications without any hidden defects, and furnish all the labor and materials required by said contract, and any and all changes in, or additions to said contract, which may hereafter be made, and shall perform all the undertakings stipulated by said bounden principal to be performed and within the time mentioned in said

contract, or within any additional time granted by the Missouri Highway and Transportation Commission or its Chief Engineer, under authority from said Commission of Missouri, which may be granted without notice to or consent from the surety, and shall pay for all materials, lubricants, fuel, coal and coke, repairs on machinery, groceries and foodstuff, equipment and tools consumed or used in connection with the construction of such work, and all insurance premiums, both compensation, and all other kinds of insurance, on said work, and for all labor performed in such work, whether by subcontractor or claimant in person or by its employee, agent, servant, bailee, or bailor, then this to be void; otherwise it shall be and remain in full force and effect.

(SEAL)

Witness: \_\_\_\_\_

\_\_\_\_\_  
Principal

By \_\_\_\_\_

Title \_\_\_\_\_

(SEAL)

\_\_\_\_\_  
Surety

By \_\_\_\_\_

Title \_\_\_\_\_

Witness: \_\_\_\_\_

Name and Street Address of Agent to Whom All  
Correspondence Should be Directed Relating to  
Contract and Bond.

\_\_\_\_\_  
Name

\_\_\_\_\_  
Street

\_\_\_\_\_  
City, State & Zip Code

**EXHIBIT 4**

**PROPOSAL BOND  
SUPPLEMENTAL GUIDE SIGN PROGRAM  
RFP #6-150504DR**

**KNOW ALL MEN BY THESE PRESENTS**, that we \_\_\_\_\_

\_\_\_\_\_ ,  
as Principal and \_\_\_\_\_, as Surety are held and firmly bound  
unto the **STATE OF MISSOURI** (acting by and through the **Missouri Highways and Transportation Commission**) in the penal  
sum of:

\_\_\_\_\_ **Dollars**  
(\$ \_\_\_\_\_) to be paid to the **State of Missouri or to the Missouri Highways and Transportation  
Commission**, to be credited to the State Road Fund, the Principal and Surety binding themselves, their heirs, executors,  
administrators, successors, and assigns, jointly and severally, firmly by these presents.

Sealed with our seals and dated this \_\_\_\_\_

**THE CONDITION OF THIS OBLIGATION** is such that:

**WHEREAS**, the Principal is submitting herewith a proposal to the Missouri Highways and Transportation Commission for furnishing  
Supplemental Guide Sign Program Administration as set out in the proposal to which this proposal is attached.

**NOW THEREFORE**, if the Missouri Highways and Transportation Commission shall accept the proposal of the Principal and if said  
Principal shall properly execute and deliver to the Missouri Highways and Transportation Commission the contract and contract bond  
in compliance with the requirements of the proposal, the specifications and the provisions of law, to the satisfaction of the Highways  
and Transportation Commission, then this obligation shall be void and of no effect, otherwise to remain in full force and effect.

In the event the said Principal shall, in the judgment of the Missouri Highways and Transportation Commission, fail to comply with  
any requirement as set forth in the preceding paragraph, then the State of Missouri acting through the Missouri Highways and  
Transportation Commission shall immediately and forthwith be entitled to recover the full penal sum above set out, together with  
court costs, attorney's fees and any other expense of recovery.

(SEAL)

\_\_\_\_\_  
Principal

By

\_\_\_\_\_  
Signature

(SEAL)

\_\_\_\_\_  
Surety

By

\_\_\_\_\_  
Attorney-in-Fact

NOTE: This bond must be executed by the PRINCIPAL and by a CORPORATE SURETY  
authorized to conduct surety business in the State of Missouri.

# ATTACHMENT - A

## **Title 7—DEPARTMENT OF TRANSPORTATION Division 10—Missouri Highways and Transportation Commission Chapter 17— Supplemental Guide Sign Program**

### **PROPOSED RULE**

#### **7 CSR 10-17.020 Definitions**

*PURPOSE: This rule provides definitions of terms.*

- (1) “Advance TODS Sign” shall mean a Tourist Oriented Directional Signing (TODS) sign placed in advance of the normal TODS sign.
- (2) “Alternate fuel” shall mean a fuel type other than gasoline or diesel that can be used to power a vehicle on the highway and includes, but is not limited to, ethanol blended gasoline (E-85), biodiesel (B-20), Compressed Natural Gas (CNG), or propane.
- (3) “Cave” shall mean a state approved cave which has complied with all necessary requirements of the Division of Labor Standards' Mine Inspection Section and possesses a current certificate of annual inspection furnished and approved by that division.
- (4) “College Emblem Sign” shall mean a supplemental guide sign displaying emblem panels of up to six (6) colleges or universities meeting the criteria in this rule on emblem panels.
- (5) “College Traffic Generator Sign” shall mean a supplemental guide sign displaying the name and logo of up to three (3) colleges or universities meeting the criteria in this rule.
- (6) “Commercial activity” shall mean any business or service activity generally recognized as commercial by zoning authorities in this state.
- (7) “Commission” shall mean the Missouri Highways and Transportation Commission.
- (8) “Crossroad” shall mean the roadway that intersects the main roadway.
- (9) “Department” shall mean the Missouri Department of Transportation.
- (10) “Emblem Panel” shall mean a panel which may display the name, logo, or a combination of both for a college or university meeting the criteria in this rule which is attached to a mainline sign or ramp sign or on a stand-alone trailblazer sign.
- (11) “Exit Ramp” or “ramp” shall mean the connective roadway between the mainline and the crossroad at an interchange.
- (12) “Expressway” shall mean a divided highway with limited numbers of at grade accesses.
- (13) “Fee” shall mean the amount of money assessed a qualified entity for participation in one (1) of the signing programs, which is paid prior to signs being installed.
- (14) “First connection” shall mean the sign location in advance of the intersection where motorists turn off of the state highway system to arrive at the destination being signed for.
- (15) “Freeway” shall mean a divided highway where access is fully controlled by interchanges.
- (16) “General Service Logo plaque” shall mean a sign with white legend on blue background depicting the standard symbol for an alternate fuel. The design shall meet the department’s standards.
- (17) “Gore” shall mean the area immediately beyond the divergence point of the mainline highway and the exit ramp bounded by the edges of those traveled ways.
- (18) “Interchange” shall mean an intersection that connects two (2) or more interconnecting roadways through the use of one (1) or more grade separations that provides for the movement of traffic between the interconnecting roadways on different elevations allowing uninterrupted flow of the mainline highway.

## ATTACHMENT - A

(19) “Intersection” shall mean the at-grade crossing of two (2) public roadways where the intersecting roadways are at the same elevations and are controlled by regulatory signs or traffic signals.

(20) “Interstate” shall mean the national system of interstate and defense highways located in Missouri as officially designated by the Missouri Highways and Transportation Commission in accordance with Title 23 of the *United States Code*, Sections 101 and 103, which is incorporated by reference and made a part of this rule as published by the United States Government Printing Office, 732 North Capitol Street, NW, Washington, DC 20401-0001, effective October 1, 2012. This rule does not incorporate any later amendments or additions.

(21) “Logo Panel” shall mean a panel which may display the name, brand, symbol, trademark, or a combination of these of a qualified entity which is attached to a mainline sign or ramp sign or serves as a stand-alone trailblazer sign when a directional arrow is installed below it.

(22) “Logo Program” or “Logos” shall mean specific service signing or a signing, which provides directional signing to businesses which offer motorist services (gas, food, lodging, camping, and twenty-four- (24-) hour pharmacy) and tourist attractions in the state of Missouri meeting the criteria of this rule.

(23) “Mainline Highway” or “mainline” shall mean the primary travel lanes of the interstate, freeway, or expressway.

(24) “Mainline Sign” shall mean the sign installed in advance of an interchange along the mainline of an interstate, freeway, or expressway informing motorists what services or attractions are accessible from that particular interchange.

(25) “Motorist Services” shall mean a business which provides one (1) or more of the following services: gas, food, lodging, camping, or twenty-four- (24-) hour pharmacy. Motorist Services shall only be associated with the Logo and TODS programs. The business must also meet the following criteria:

(A) Gas and diesel vehicular service stations shall provide fuel, oil, water, air, restroom facilities, drinking water, a telephone available for public use, and be in continuous operation at least twelve (12) hours a day, seven (7) days per week. Alternate vehicle fuels availability at these sites can be displayed as a secondary message at the bottom of a Logo panel or within the legend of the sign legend on a TODS sign. If this information cannot be displayed as part of the Logo or TODS sign, it may be displayed as a general service logo plaque placed below the gas Logo mainline and ramp signs or below the TODS sign for the facility offering the alternate fuel. A maximum of two (2) plaques may be displayed below a TODS sign, one (1) attached to each of the TODS sign posts. When general service logo plaques are used, the fuel station shall be within three (3) miles of the interchange, located along the crossroad of the interchange, be clearly visible from the cross road and the availability of the alternate fuel shall be clearly identified on the on-premise signing of the fuel station. The distance to the service fuel station shall be displayed along with the general service logo where the distance is greater than one (1) mile;

(B) Food and restaurant facilities shall be approved and/or licensed by the state or political entity having jurisdiction and be in continuous operation to serve a minimum of two (2) meals a day (breakfast, lunch, and/or dinner), six (6) days a week and be open to the public a minimum of twelve (12) hours per day. The facility must have accommodations to seat a minimum of twenty (20) guests at tables indoors or a minimum of ten (10) drive-up ordering/eating stations. They must also provide restroom facilities and a telephone available for public use;

## ATTACHMENT - A

(C) Lodging, motel, and hotel facilities shall be approved and/or licensed by the state agency or political entity having jurisdiction and provide adequate sleeping accommodations and telephone availability for public use. The facility must have a minimum of ten (10) rooms and sufficient off street parking. The facility shall be open twenty-four- (24-) hours a day, seven (7) days a week;

(D) Camping and campground facilities shall be approved and/or licensed by the state agency or political entity having jurisdiction and provide modern sanitary facilities and drinking water. They must also provide a minimum of twenty (20) camping and parking spaces. The facilities shall be open twenty-four- (24-) hours a day, seven (7) days a week for a minimum of six (6) consecutive months per year. Signing for campgrounds operated on a seasonal basis will be covered with a blue background aluminum panel of appropriate size or removed from the sign during the off season; and

(E) Twenty-four- (24-) hour pharmacies shall be continuously operated twenty-four (24) hours per day, seven (7) days per week, and shall have a state-licensed pharmacist on duty at all times.

(26) "Owner" shall mean the holder of a fee title or the holder of a leasehold estate from the owner of real property representing the qualified entity.

(27) "Participation agreement" shall mean a contract between the program manager and each eligible entity participating in the programs outlined in this rule.

(28) "Program manager" shall mean a person representing the company awarded the administrative services contract for the purpose of operating the Logo, TODS, and Traffic Generator Programs and is authorized by the department to sign a participation agreement for marketing, management, installation, and maintenance of signs for these programs in accordance with these rules.

(29) "Qualified Entity" shall mean a site that meets one (1) of the following categories and meets all of the criteria listed in this rule:

(A) A tourist oriented activity;

(B) A motorist service;

(C) A state or federal agency which owns and operates a site offering recreational activities, sites of historical significance or manages public lands open to the public.

(D) A state operated correctional facility;

(E) A Welcome Center Affiliate; and

(F) A college or university, satellite campus, or community college which offers face to face classroom education as the primary purpose of the site.

(30) "Ramp Sign" shall mean the supplemental guide for the Logo or Traffic Generator Program installed along the interchange ramp providing directional information for each service or attraction accessible from that particular interchange.

(31) "Ramp Terminal" shall mean the intersection of the exit ramp and the crossroad.

(32) "Rural Area" shall mean an area in which the population is less than five thousand (5,000) persons.

(33) "Second connection" shall mean the sign location in advance of the intersection or interchange where motorists turn to access the state highway where first connection signing is provided.

(34) "Specific Service sign" shall mean a supplemental guide sign displaying Logo panels for specific businesses that provide eligible motorist services or tourist attractions as outlined in this rule.

## ATTACHMENT - A

(35) “Standard” shall mean the department’s Standard Plans for Highway Construction and/or Standard Specifications for Highway Construction and/or policies found in the Engineering Policy Guide.

(36) “Third connection” shall mean the sign location in advance of the intersection or interchange where motorists turn to access the state highway where second connection signing is provided.

(37) “TODS Program” or “TODS” shall mean Tourist Oriented Directional Signing, a signing program, which provides directional signs to tourist oriented activities and motorist services in the state of Missouri meeting the criteria of this rule.

(38) “TODS sign” shall mean a sign displaying the name of qualified entities that provide eligible tourist attractions or motorist services as outlined in this rule displayed as a stand-alone sign or as part of a TODS sign assembly.

(39) “Tourist Attraction” shall mean a tourist oriented activity which means a natural phenomenon, historic site, cultural site, recreational site, educational site, museum, area of natural beauty, or commercial activity as defined below, a major portion of whose income or visitors are derived during the normal business season from motorists. Attendance in any consecutive twelve- (12-) month period shall meet or exceed the minimum requirements established in this rule for the Logo, TODS, or Traffic Generator programs. Tourist attractions shall be open for business at least four (4) hours per day, at least five (5) days per week, one (1) of which must be a Saturday or Sunday unless otherwise indicated in this rule, have public restroom facilities, and a minimum of ten (10) parking accommodations.

(A) “Natural phenomenon” shall mean a feature created by nature. Examples may include, but are not limited to, unusual rock formations, caves, geysers, or waterfalls.

(B) “Historic site” shall mean a structure, site, or district that has definite historical significance and shall be listed on the National Register of Historic Places.

(C) “Cultural site” shall mean any facility for the performing arts, exhibits, or concerts that is open to all age groups.

(D) “Museum” shall mean a facility open to the public at least one hundred (100) days per year, in which works of artistic, historical, or scientific value are cared for and exhibited to all age groups.

(E) “Educational site” shall include:

1. “Zoological” or “botanical park” shall mean a facility in which living animals, insects, or plants are kept and exhibited to the public;

2. “Facility tours” shall mean regularly scheduled tours of plants, factories, working farms, or institutions where the tours are conducted on a regularly scheduled daily basis for the general public without the need for reservations conducted during normal working hours of the facility. Tours shall be a minimum of thirty (30) minutes in duration. Tours shall be educational in format, informing the public how the products from the facility are produced or grown. The availability of tours shall be made known to the general public by posting the information on the facility website, pamphlets, and brochures or anywhere the hours of operation for the facility can be found. Retail outlets who do not fabricate or grow their products do not qualify; and

3. “Wineries” or “breweries” which qualify in the educational category shall mean a licensed site which produces a minimum of five hundred (500) gallons of wine and/or beer per year, which is open to the public for guided tours, tasting and sells a minimum of one hundred (100) days per year. The tours shall meet the requirements defined

## ATTACHMENT - A

under “facility tours.”

(F) “Area of natural beauty” shall mean a naturally occurring area of outstanding interest to the general public. Examples may include, but are not limited to, state or national parks, wilderness areas, lakes, rivers, canyons, or similar areas.

(G) “Recreational site” shall include:

1. “Recreational area” shall mean an area that includes, but is not limited to, bicycling, boating, fishing, swimming, hiking, rafting, picnicking, snowmobiling, cross country skiing, or snow skiing;

2. “Amusement parks” shall mean a permanent area which is open to the general public offering entertainment including, but not limited to, games, rides, and/or food services for all ages and is in operation more than three (3) consecutive months per year;

3. “Arenas” shall mean a stadium, sports complex, auditorium, fairgrounds, civic or convention center, or racetrack which have at least seating for five thousand (5,000) people holding public events open to all groups on at least one hundred (100) days of the year;

4. “Golf course” shall mean a facility open to the public and offering at least nine (9) holes of play. Miniature golf courses, driving ranges, and indoor golf shall not be eligible; and

5. “Excursion gambling boat” shall mean a boat, ferry, or other floating facility licensed by the gaming commission on which gambling games are allowed.

(40) “Traffic generator” shall be a qualified entity, not including motorist services, golf courses, or excursion gambling boat, which meet the criteria of this rule.

(41) “Traffic Generator Program” shall mean a supplemental guide sign program, which provides guidance to qualified entities, schools, governmental agencies, and colleges meeting the criteria in this rule.

(42) “Traffic Generator Sign” shall mean a supplemental guide displaying the name and logo, when permissible in this rule, of the qualified entity meeting the criteria in this rule.

(43) “Trailblazer sign” shall mean a sign with an arrow and site name/logo information which provides directional information for any necessary turns from the furthest extent of the signing to the qualified entity’s location. Legal, off-premises, directional outdoor advertising may be substituted for trailblazer signs if erected prior to the installation of a Logo or TODS sign.

(44) “Urban Area” shall mean an area in which the population is greater than five thousand (5,000) persons.

(45) “Visible” shall mean that the message or advertising content of a sign, display, or device is capable of being seen without visual aid by a person of normal visual acuity. A sign shall be considered visible even though the message or advertising content may be seen but not read.

(46) “Welcome Center Affiliate” shall mean a local chamber of commerce, a local convention and visitor bureau or an institution of higher education with an established tourism curriculum which serves to increase the number of welcome centers in Missouri without expending state funds meeting the criteria of this rule.

*AUTHORITY: Art. IV, section 29, Mo. Const., section 226.535, RSMo 2000 and 23 United States Code Section 131(f). Material in this rule originally filed as 7 CSR 10-9, 7 CSR 10-17, and 7 CSR 10-22. Original rule filed November 14, 2014.*

*PUBLIC COST: This proposed rule will not cost state agencies or political subdivisions more than five hundred dollars (\$500) in the aggregate.*

## ATTACHMENT - A

*PRIVATE COST: This proposed rule will not cost private entities more than five hundred dollars (\$500) in the aggregate.*

*NOTICE TO SUBMIT COMMENTS: Anyone may file a statement in support of or in opposition to this proposed rule with the Missouri Department of Transportation, Pam Harlan, Secretary to the Commission, PO Box 270, Jefferson City, MO 65102. To be considered, comments must be received within thirty (30) days after publication of this notice in the **Missouri Register**. No public hearing is scheduled.*

# ATTACHMENT - A

## **Title 7--DEPARTMENT OF TRANSPORTATION Division 10--Missouri Highways and Transportation Commission Chapter 17— Supplemental Guide Sign Program**

### **PROPOSED RULE**

#### **7 CSR 10-17.030 Administration**

*PURPOSE: This rule provides information concerning obtaining, maintaining, and cost for signing.*

- (1) This rule outlines the eligibility requirements to participate in the various signing programs. The construction, installation, and maintenance of the signs shall be in accordance with the “Supplemental Signing Program Rules” located in the department’s Engineering Policy Guide.
- (2) Signs covered in this rule only apply to commission roadways unless otherwise specified in this rule.
- (3) Requests for participation in the Logo, Tourist Oriented Directional Signing (TODS), or Traffic Generator Programs must be submitted to the program manager by the owner or authorized representative of a qualified entity.
- (4) Before any qualified entity is permitted to participate in the Logo, TODS, or Traffic Generator Programs, any existing illegal advertising devices pertaining to that qualified entity shall be removed.
- (5) No qualified entity may discriminate or be discriminated against with regard to race, color, religion, sex, age, handicap, or national origin. Each qualified entity identified by a Logo, TODS, or Traffic Generator sign shall have furnished written and notarized certification to the program manager of its conformity with all applicable federal, state, and local laws, ordinances, rules and regulations, and shall not be in breach of that certification.
- (6) A qualified entity shall enter into a participation agreement with the program manager.
- (7) Signs may be removed after notification by certified mail a minimum of thirty (30) days in advance of permanent removal of a qualified entity’s sign, for any of the following and no fees shall be refunded:
  - (A) Failure to pay fee;
  - (B) Failure to meet the minimum requirements set forth by these rules for each program type;
  - (C) Delinquency as to any of the previously mentioned violations; and
  - (D) A sign removed for any of the reasons in subsections (7)(A)-(7)(C) shall be charged a department approved fee for re-installation.
- (8) If a business is closed due to fire, accident, remodeling, or other emergency for more than seven (7) days, but not more than ninety (90) days, the sign shall be covered to prevent inconveniencing the traveling public. The sign owner shall not lose its priority or be required to reapply prior to the normal expiration of its contract. Extensions of time beyond ninety (90) days may be granted; however, an owner who, due to his/her own negligence, fails to open within the ninety- (90-) day period, may lose his/her priority to occupy the space on the right-of-way. The participation agreement will not be extended due to fire, accident, remodeling, or other emergency.
- (9) The fee to be paid shall be equal to the fees established by the department. A participation agreement with the qualified entity shall be executed for a term specified in each program. If an applicant chooses to not pay the fees agreed upon in the participation agreement, all signs will be

## ATTACHMENT - A

removed from the commission right-of-way.

(10) At the end of their business season, a qualified entity not open year-round shall have their sign taken out of service with a “Closed” panel placed on their traffic generator sign(s), place a “Closed” panel and cover with a blue panel, or the program manager shall have the authority to remove their TODS or Logo sign.

(A) A qualified entity which has not received a sign(s) due to insufficient space shall not utilize the space made available by a qualified entity’s sign which has been removed during the off-season.

(B) A fee, approved by the commission, shall be assessed to take a sign in and out of service.

(11) No reimbursement shall be allowed to any participating qualified entity due to road closures or detours established for any reason.

(12) The commission reserves the right to approve all sign installation locations, modify said sign(s) when necessary to comply with changed standards that might be promulgated or adopted, and/or permanently remove the sign(s) at any time, in its sole discretion, for any reason whatsoever, including for the convenience of the commission or if the commission determines removal is required for a highway or transportation project. In the event the commission removes the sign pursuant to the terms of this rule, the commission will not refund any portion of the original payment from the qualified entity.

*AUTHORITY: Art. IV, section 29, Mo. Const., section 226.535, RSMo 2000 and 23 United States Code Section 131(f). Material in this rule originally filed as 7 CSR 10-9, 7 CSR 10-17, and 7 CSR 10-22. Original rule filed November 14, 2014.*

*PUBLIC COST: This proposed rule will not cost state agencies or political subdivisions more than five hundred dollars (\$500) in the aggregate.*

*PRIVATE COST: This proposed rule will not cost private entities more than five hundred dollars (\$500) in the aggregate.*

*NOTICE TO SUBMIT COMMENTS: Anyone may file a statement in support of or in opposition to this proposed rule with the Missouri Department of Transportation, Pam Harlan, Secretary to the Commission, PO Box 270, Jefferson City, MO 65102. To be considered, comments must be received within thirty (30) days after publication of this notice in the **Missouri Register**. No public hearing is scheduled.*

# ATTACHMENT - A

## **Title 7—DEPARTMENT OF TRANSPORTATION Division 10—Missouri Highways and Transportation Commission Chapter 17— Supplemental Guide Sign Program**

### **PROPOSED RULE**

#### **7 CSR 10-17.040 Tourist Oriented Directional Signing Requirements**

*PURPOSE: This rule defines the requirements necessary for an entity to qualify for Tourist Oriented Directional Signing (TODS) signing.*

(1) A qualified entity eligible for Tourist Oriented Directional Signing (TODS) signs shall meet the criteria as tourist attraction or a motorist service (not including twenty-four- (24-) hour pharmacies) as defined in this rule and signing will be limited to the following distances from the site:

(A) Gas, food, and lodging services - three (3) miles; and

(B) Camping services and tourist attractions - fifteen (15) miles.

(2) If the installation of a TODS sign directing traffic onto a non-state route at an intersection is determined to be necessary by the program manager, the program manager shall contact the appropriate local jurisdiction who owns the roadway and obtain written consent for such TODS installation. If permission for erecting trailblazing signs cannot be obtained from the appropriate local authorities, that qualified entity shall not be eligible for TODS at that intersection.

(3) Where both TODS and Logo trailblazer signing would be authorized at the same intersection, the TODS signs shall incorporate the required information from, and be used in place of, the Logo trailblazer sign.

(4) Whenever an intersection on an expressway is upgraded to an interchange, all TODS located at that interchange and any associated trailblazing signs shall be removed by the program manager.

(5) Only those qualified entities not plainly visible to the driver proceeding on the crossroad will be considered for trailblazing signs. When the program manager determines trailblazer signs are required, all trailblazing signs shall be erected prior to erecting the intersection signs.

*AUTHORITY: Art. IV, section 29, Mo. Const., sections 226.020, 226.130 and 226.525, RSMo 2000. Material in this rule originally filed as 7 CSR 10-9, 7 CSR 10-17, and 7 CSR 10-22. Original rule filed November 14, 2014.*

*PUBLIC COST: This proposed rule will not cost state agencies or political subdivisions more than five hundred dollars (\$500) in the aggregate.*

*PRIVATE COST: This proposed rule will not cost private entities more than five hundred dollars (\$500) in the aggregate.*

*NOTICE TO SUBMIT COMMENTS: Anyone may file a statement in support of or in opposition to this proposed rule with the Missouri Department of Transportation, Pam Harlan, Secretary to the Commission, PO Box 270, Jefferson City, MO 65102. To be considered, comments must be received within thirty (30) days after publication of this notice in the **Missouri Register**. No public hearing is scheduled.*

# ATTACHMENT - A

## **Title 7—DEPARTMENT OF TRANSPORTATION Division 10—Missouri Highways and Transportation Commission Chapter 17— Supplemental Guide Sign Program**

### **PROPOSED RULE**

#### **7 CSR 10-17.050 Requirements for Logo Signing**

*PURPOSE: This rule defines the requirements necessary for an entity to qualify for Logo signing.*

(1) A qualified entity must provide one (1) or more of the following services: gas, food, lodging, camping, twenty-four- (24-) hour pharmacy, or be a tourist attraction meeting the criteria found in this rule to be eligible to participate in the Logo signing program.

(A) Specific service signs shall be erected only for a qualified entity located within three (3) miles of the interchange as measured along the path from the interchange to the qualified entity. The measurement starting from the intersecting centerlines of the freeway and crossroad at the interchange to the nearest edge of the business structure projected at a right angle to the roadway centerline. If the capacity of the existing individual service sign for a specific business is not fully utilized, a successive three- (3-) mile increment may be considered for that specific type business on a temporary basis until the space is requested by a qualified entity within the initial three- (3-) mile distance. The qualified entity occupying the space on a temporary basis will remain in place to the end of its annual participation agreement. Existing signs shall not be made larger or new signs installed to make room for qualified entities beyond the initial three- (3-) mile distance. The maximum distance allowed for each category from the interchange is equal to:

1. Gas, food, and lodging services - six (6) miles;
2. Camping services or Tourist attractions - fifteen (15); and
3. Twenty-four- (24-) hour pharmacies - three (3) miles.

(B) Locations for mainline, ramp, and trailblazer signs must be approved by the department.

(C) Messages, symbols, and trademarks which resemble any official traffic control device shall not be used.

(D) If logo spaces for any of the service categories mentioned in this rule remain available, then the department, at its discretion, may permit other qualifying entities in the same service category meeting the majority of the criteria to utilize the otherwise unused spaces. Those qualified entities that participate, but do not fully qualify for the program, shall be reevaluated on an annual basis. At that time, should there be a request from a fully qualifying entity to participate, the fully qualifying entity shall be given priority over a less than fully qualifying entity when considering renewal of contracts.

(E) A business may have Logo panels installed at a second interchange, provided it meets all the requirements as set forth in these regulations and its participation at the second interchange does not prevent another eligible business from participating in the Logo Program at that interchange. Should a qualified entity choose to participate in the Logo Program at the second interchange location, the business occupying space at the second interchange will be removed when its participation agreement has expired.

(F) In the event that a business provides more than one (1) motorist service, it may be eligible to display a Logo panel for each service it provides on the proper specific service sign,

## ATTACHMENT - A

provided the following conditions are met:

1. It meets all minimum criteria for the service;
  2. It does not prevent participation by another business which offers a sole service and would otherwise qualify for placement on the specific service sign. Should a qualified entity choose to participate in the Logo Program at one (1) of the locations the business is displaying a secondary motorist service, the secondary Logo panel will be removed when its participation agreement expires; and
  3. Space is available on the specific service sign.
- (2) When more than six (6) qualified entities of the same motorist service type wish to participate in the Logo program at the same interchange, up to six (6) Logo panels for this motorist service type may be installed, or roll over, onto a second specific service sign if the second specific service sign is empty or can be subdivided as stated in the supplemental signing program rules. No more than twelve (12) Logo panels for one (1) type of motorist service shall be displayed at a single interchange on a maximum of two (2) specific service signs. The qualified entities occupying space on the second specific service sign may remain in place until such time as the space is needed by other qualified entities of other motor service types not currently displayed at the interchange choose to participate in the Logo program at that interchange. When this occurs, the qualified entities which rolled over onto the second specific service will remain in place until their participation agreement expires.
- (3) If the requests to place Logo panels on specific service signs exceed the available space, the following criteria shall be used to determine the allocation of spaces:
- (A) Businesses nearest to the interchange will be given priority;
  - (B) The first six (6) qualified applicants for gas, food, lodging, camping, tourist attractions and pharmacies, shall be selected to place their Logo panels on the specific service sign. When a tourist attraction and another motor service type are combined on a single specific service sign, the first three (3) qualified tourist attractions and first three (3) of the other motor service type that share the same specific service sign shall be selected;
  - (C) Once all allowed similar type businesses are posted on the specific service sign at an interchange, other similar type businesses that are on the waiting list that are closer to the interchange shall have priority over the business furthest from the interchange that is also on the waiting list; and
  - (D) Changes in the Logo panels displayed on the specific service sign which result from the previous rules will take place when the participation agreement for the business in question on the specific service sign expires.
- (4) If trailblazer signs are required for qualified entities, they shall be installed at the same time or prior to the installation of the Logo panel on the mainline and ramp signs. The program manager shall determine if trailblazer signs are necessary and the department will approve locations, if appropriate.
- (5) Where both Tourist Oriented Directional Signing (TODS) and Logo trailblazer signing would be needed at the same intersection, the TODS signs shall incorporate the needed information from, and be used in place of the Logo trailblazer sign.
- (6) Mainline Logo signs shall be located on the freeway mainline between the first advanced guide sign and the exit guide sign.
- (7) Ramp signs shall be located along the freeway interchange ramp after the gore and before the ramp terminal.
- (8) Logo panels shall be constructed and installed as follows:

## ATTACHMENT - A

(A) Only a qualified entity's name, brand name, trademark, corporate logo, or commercial symbol shall be used. Logo and word messages shall not both be displayed on the logo unless otherwise permitted in this rule. If a nationally, regionally, or locally recognized commercial symbol, corporate logo or trademark is available, it should be used in preference to any other form of business identification. The department has the right to review and approve or deny the requested design;

1. The logo panel for a gas station/convenience store may display names, brand names, trademarks, corporate logos, commercial symbols, or other words, signs or symbols representing the brand of motor fuel and the convenience store name so long as the same or substantially similar words, signs or symbols are permanently displayed on the business and are the same or substantially similar to the business name, business entity or the doing business as ("dba") name as registered with the Missouri Secretary of State's office; and

2. The federal regulation on this issue, as interpreted by FHWA guidance, suggests that blended logo panels are not allowed; however, the language of the federal regulation appears to allow this compromise so long as both logos are contained in the business name, business entity or "dba".

(B) Logo panels shall not display a message which advertises a product rather than identifying a business. Any exception must be approved by the department. On gas logo panels, diesel, ethanol or E-85, Biodiesel or B20, Compressed Natural Gas or CNG, Propane, or Food Mart text may be included as a secondary message in the lower portion of the logo panel; and

(C) Messages, corporate logos, symbols, or trademarks which interfere with, imitate or resemble any official warning or regulatory sign, signal, or traffic control device or which attempt, or appear to attempt, to direct movement of traffic are prohibited.

*AUTHORITY: Art. IV, section 29, Mo. Const., section 226.535, RSMo 2000 and 23 United States Code Section 131(f). Material in this rule originally filed as 7 CSR 10-9, 7 CSR 10-17, and 7 CSR 10-22. Original rule filed November 14, 2014.*

*PUBLIC COST: This proposed rule will not cost state agencies or political subdivisions more than five hundred dollars (\$500) in the aggregate.*

*PRIVATE COST: This proposed rule will not cost private entities more than five hundred dollars (\$500) in the aggregate.*

*NOTICE TO SUBMIT COMMENTS: Anyone may file a statement in support of or in opposition to this proposed rule with the Missouri Department of Transportation, Pam Harlan, Secretary to the Commission, PO Box 270, Jefferson City, MO 65102. To be considered, comments must be received within thirty (30) days after publication of this notice in the **Missouri Register**. No public hearing is scheduled.*

# ATTACHMENT - A

## **Title 7--DEPARTMENT OF TRANSPORTATION Division 10--Missouri Highways and Transportation Commission Chapter 17— Supplemental Guide Sign Program**

### **PROPOSED RULE**

#### **7 CSR 10-17.060 Requirements for Traffic Generators**

*PURPOSE:* This rule defines the requirements necessary for an entity to qualify for traffic generator signing.

- (1) A traffic generator is eligible to have signs up to the third connection, however, signing cannot extend beyond the first interchange encountered regardless if the interchange is the first, second, or third connection.
- (2) Traffic generator signing shall not be installed at an interchange which connects to another freeway. No interchange to interchange signing is permitted.
- (3) Traffic generator signs shall not be erected at an interchange where one (1) exit ramp splits into two (2) or more ramps before connecting to the crossroad.
- (4) Traffic generator signs shall not be erected in an area where there is less than three-quarters (3/4) of a mile between interchange gore points when measured in one (1) direction or as approved by the department.
- (5) Signs may be provided on each freeway located within fifteen (15) miles of the traffic generator in a rural area or within five (5) miles in an urban area as measured along the path from the interchange/intersection to the traffic generator. The distance is measured along the path starting from the intersecting centerlines of the interchange/intersection and the crossroad and ends at the nearest edge of the traffic generator projected at a right angle to the roadway centerline.
- (6) The qualified entity is responsible for working with the local jurisdiction to install any additional trailblazer signs that may be required off of the state system before the signs are installed on the state highway.
- (7) Tourist Oriented Traffic Generator. To be considered eligible as a tourist oriented traffic generator a qualified entity must meet the definition of a tourist oriented attraction, meaning the definition in this rule, and must also meet the following criteria:
  - (A) The qualified entity shall have a minimum annual attendance of two hundred thousand (200,000) in rural areas, two hundred and fifty thousand (250,000) in urban areas and three hundred thousand (300,000) in the St. Louis and Kansas City metropolitan areas;
  - (B) Shall be open for business at least four (4) hours per day, at least five (5) days per week, one (1) of which must be a Saturday or Sunday and be fully operative and open to the traveling public for a minimum of three (3) months each year unless otherwise indicated in this rule, have public restroom facilities, have sufficient on premise parking to accommodate all visitors; and
  - (C) The qualified entity shall meet the criteria for a tourist oriented attraction specified in this rule.
- (8) College Generator. To qualify for college generator signs a qualified school shall meet all the definitions of this rule and must also meet the following criteria:
  - (A) The school shall be a traditional four- (4-) year college, theological school, or seminary;

## ATTACHMENT - A

- (B) The qualifying school site and the courses taught at the school shall be accredited by an organization recognized by the U.S. Department of Education or by the Council for Higher Education. The department will determine the eligibility of each school;
  - (C) The qualifying school shall provide a minimum of a four- (4-) year bachelor's degree or master's degree;
  - (D) The qualifying school shall be the primary campus of the college;
  - (E) Two- (2-) year colleges, community colleges, professional/technical schools, or satellite campuses do not qualify for college generator signing;
  - (F) The qualifying school shall provide on campus student housing;
  - (G) The qualifying school shall offer traditional, face to face classroom settings between students and faculty as a primary source of education. Web-based or telecommunication centers do not meet this requirement;
  - (H) College generator signs shall only provide guidance to the primary school campus. Signing to individual schools on or off campus (i.e. school of engineering, nursing, etc.), research parks, or research farms shall not be provided;
  - (I) Qualifying schools may choose to participate in college emblem signing in lieu of college generator signing;
  - (J) If third connection does not reach an interchange, the signing will begin at the third connection and the signing will consist of college generator trailblazer signs only;
  - (K) The qualifying school shall have a minimum of five hundred (500) registered students attending face to face classes on campus. The department shall acquire the three- (3-) year average attendance from the Department of Higher Education or the school may provide a notarized letter attesting to their average face to face enrollment for the specific site being signed for.
  - (L) The logo for the school shall only be displayed on the mainline sign; and
  - (M) No qualified school may participate in more than one (1) type of college traffic generator signing program off of a given state highway.
- (9) College Emblem Signing. To qualify for college emblem signs a qualified school shall meet all the definitions of this rule and must also meet the following criteria:
- (A) The qualifying school shall be a minimum of a two- (2-) year college, community college, or satellite campus;
  - (B) The qualifying school site and the courses taught at the school shall be accredited by an organization recognized by the U.S. Department of Education or by the Council for Higher Education. The department will determine the eligibility of each school;
  - (C) The qualifying school shall provide a minimum of a two (2) year associate's degree;
  - (D) The qualifying school shall offer traditional, face-to-face classroom settings between students and faculty as a primary source of education. Web-based or telecommunication centers do not meet this requirement;
  - (E) College emblem signs shall only provide guidance to the primary school campus. Signing to individual schools on or off campus (i.e. school of engineering, nursing, etc.), research parks, or research farms shall not be provided;
  - (F) If third connection does not reach an interchange, the signing will begin at the third connection. The type of signing used to mark the path will consist of college emblem style trailblazer sign only;
  - (G) The qualifying school shall have a minimum of one hundred (100) registered students attending face-to-face classes on campus. The department shall acquire the three- (3-) year

## ATTACHMENT - A

average attendance from the U.S. Department of Higher Education or the school may provide a notarized letter attesting to their average face-to-face enrollment for the specific site being signed for; and

(H) No qualified school may participate in more than one (1) type of college traffic generator signing program off of a given state highway.

(10) State and Federal Agency. State and federal agency traffic generators are required to meet the criteria in this rule for traffic generators, but do not have a minimum annual attendance requirement. State and federal agency traffic generators shall be limited to-

(A) Missouri conservation areas operated by the Missouri Department of Conservation;

(B) Missouri state parks and state historic sites operated by the Missouri Department of Natural Resources; and

(C) Federal agency traffic generators shall be limited to recreational sites, including, but not limited to, historic sites, forests, river accesses, campgrounds and lakes, which are operated by U.S. Corp of Engineers, U.S. Forest Service, U.S. Fish and Wildlife, or National Park Service.

(11) State Correction Centers. Correction centers operated by the Missouri Department of Corrections are eligible for traffic generator signs at the first connection only. If the first connection is at an interchange, the first connection may include both the mainline and ramp sign. Before signing will be considered, approval from the local government where the correctional facility is located must be obtained. Minimum attendance requirements do not apply.

(12) Welcome Center Affiliate. Welcome center affiliates, approved by the Division of Tourism, are eligible for traffic generator signs and are required to meet the criteria in this rule, but do not have a minimum annual attendance requirement. Signs will be allowed up to a maximum of six (6) miles from the affiliate in a rural area and two (2) miles in an urban area. Before the participation agreement can be executed, the potential affiliate must first receive their certification letter from the Division of Tourism.

*AUTHORITY: section 226.525, RSMo 2000 and 23 U.S.C. section 131. Material in this rule originally filed as 7 CSR 10-9, 7 CSR 10-19, and 7 CSR 10-22. Original rule filed November 14, 2014.*

*PUBLIC COST: This proposed rule will cost public entities one thousand four hundred and fifty two dollars (\$1,452) in FY 2016. For the years after FY 2016, the total annual aggregate cost is four thousand seven hundred and nineteen dollars (\$4,719) for the life of the rule.*

*PRIVATE COST: This proposed rule will not cost private entities more than five hundred dollars (\$500) in the aggregate.*

*NOTICE TO SUBMIT COMMENTS: Anyone may file a statement in support of or in opposition to this proposed rule with the Missouri Department of Transportation, Pam Harlan, Secretary to the Commission, PO Box 270, Jefferson City, MO 65102. To be considered, comments must be received within thirty (30) days after publication of this notice in the **Missouri Register**. No public hearing is scheduled.*

# **ATTACHMENT - B**

## **Draft EPG Section 903.x.x**

### **Policy for Sign Administration**

(1) Qualified entities wanting to participate in the Logo, TODS, or Traffic Generator Programs shall apply for participation with the program manager. If the program manager finds the application to be complete and determines that the entity qualifies for one of the programs, the program manager shall so notify the applicant in writing. Upon receipt of the notice, the applicant shall forward to the program manager, the amount of the fee and thereupon shall execute a participation agreement with the program manager.

The program manager shall contact in writing the department's Division of Design, Right-of-Way Unit to determine the existence of illegal advertising devices. If within thirty (30) calendar days no answer is received from the Division of Design, Right-of-Way Unit, the program manager shall assume there are no illegal advertising devices in place pertaining to that qualified entity.

(2) A qualified entity shall enter into a participation agreement with the program manager. In doing so the qualified entity agrees to the terms and conditions set forth in this policy and understands that the fees paid only allows participation in the program and afford them no ownership in the signs their business is displayed upon. The signs and all materials associated with the installation shall remain the property of the commission.

(3) The program manager shall determine if trailblazer signs are necessary and the department will approve locations, if appropriate.

(4) The qualified entity will be notified by certified mail a minimum of thirty (30) days in advance of the permanent removal of their sign for any cause.

(5) The fee to be paid shall be equal to the fees established agreed to and approved by the Commission. A participation agreement with the qualified entity shall be executed for a term specified in each program. If the qualifying entity fails to pay the required annual fees, the participation agreement will be considered void and all signs/Logo panels will be removed from the commission right of way.

(6) The program manager will review all existing qualified entity's operations to assure each qualified entity is still in compliance with the appropriate rule before renewing the participation agreement.

(7) The department will review all proposed locations for new mainline, ramp, and trailblazer sign installations to determine if there is a conflict with existing signs or future sign installations. The department reserves the right to investigate businesses for compliance with state statutes and regulations.

## **ATTACHMENT - B**

(8) Fees assessed to qualified entities for participating in the Logo, TODS, Traffic Generator, College, State and Federal Agency, Welcome Center Affiliate and State Correctional Center signing programs shall be set forth in writing by the program manager and shall be uniform for all qualified entities. The program manager shall not revise the fees charged to qualified entity for participation in these programs without prior approval of the director.

(9) A qualified entity for which a participation agreement is in effect must immediately notify the program manager for cancellation if the qualified entity ceases operation or no longer meets the criteria set forth in the rules.

(A) It shall be the responsibility of the qualified entity to notify the program manager to take their sign(s) out of service at the beginning of a closed season and re-instate their sign(s) at the beginning of the open season.

(B) If a qualified entity is closed for more than two (2) weeks during the normal business season, the sign(s) shall be taken out of service as previously specified. It shall be the responsibility of the qualified entity to notify the program manager of any such closure and when the site has reopened.

(C) It shall be the responsibility of the program manager to monitor seasonal qualified entities to make sure their signs are properly displayed.

(10) The program manager, in conjunction with their marketing process, shall establish an application procedure for interested tourist oriented activities. Such procedure shall be approved by the director prior to implementation.

(11) The program manager shall document and maintain records of all qualified entities who are contacted or who contact the program manager regarding participation in the Logo, TODS or Traffic Generator programs. The Traffic Generator Program includes signing for privately owned and operated Tourist Oriented Sites, Colleges, State and Federal Agencies, Welcome Center Affiliates and State Correctional Centers.

(12) The operator of any participating attraction for which a participation agreement is in effect must immediately notify the program manager for cancellation if the qualified entity ceases to be such an attraction.

(13) The program manager shall maintain all signs in a serviceable condition in accordance with the department and MUTCD standards including, but not limited to, appearance, retroreflectivity, and breakaway safety features. Maintenance actions to correct deficiencies must be pre-approved by the department. "Serviceable condition" shall mean that a sign has not deteriorated due to loss of reflectivity, vandalism, accident or natural disaster, to the point where the sign is unable to effectively perform its intended function both during daylight and night time conditions. Signs must meet minimum federal standards for retroreflectivity and appearance and shall be maintained in accordance with one of the approved management methods as outlined in the Manual on Uniform Traffic Control Devices.

## **ATTACHMENT - B**

### **Policy for Tourist Oriented Directional Signing Requirements**

(1) At eligible intersection legs, if a new qualified entity is established, or if a nonparticipating qualified entity is interested in participating in the TODS Program, the qualified entity may request to participate in the program. Additional applications will be considered in accordance with the priorities already established.

(2) If a qualified entity, as established by the administrative rule for the TODS program, ceases to be a qualified entity per the criteria of the administrative rule by the program manager, the signs shall be removed and participation in the program may be offered to the next qualified entity.

(3) If a qualified entity for which TODS are in place is sold, the new owner(s) shall submit a new program application.

(A) New signs shall be required if the name, logo or symbol changes.

(B) A simple change of ownership does not constitute justification for erecting new signs.

(4) TODS signing is only eligible to be placed on right-of-way owned and maintained by the commission unless otherwise specified in this policy.

(5) If TODS trailblazer signs are needed to direct traffic across a non-MHTC roadway facility, the program manager shall obtain written consent from the local jurisdiction to do so. If consent is not granted the applicant will be considered to no longer be eligible to participate in the program.

(6) No qualified entity shall have more than two (2) TODS signs displayed on any one (1) given route, one (1) sign per direction of travel in advance of the intersection. These signs may be split between two (2) different intersections if the most direct route to the qualified entity is not the same for each direction of travel on the mainline highway.

(7) Only ground mounted TODS signs will be permitted. TODS signs shall not be installed on overhead sign structures or bridges. If there is insufficient ground space to accommodate the placement of the TODS sign without interfering or conflicting with other commission highway signing, the department has the right to deny the request for TODS signing.

(8) A maximum of three (3) TODS signs shall be displayed on one TODS Assembly and no more than three (3) TODS assemblies shall be permitted in advance of any given intersection. A "TODS Assembly" shall mean a supplemental guide sign made up of one (1) and up to three (3) TODS signs installed on one (1) set of sign posts.

(9) Advanced TODS signs may be installed only in limited situations where sight distance, intersection vehicle maneuvers, or other vehicle operating characteristics require advanced notification of the destination and their directions. The design of the advance TODS sign shall be the same as the TODS sign with the exception that it will not display the directional arrow and

## ATTACHMENT - B

mileage. The advance TODS sign shall be displayed with an additional panel mounted over the TODS sign panel(s) displaying the action message NEXT LEFT, NEXT RIGHT, or AHEAD. The use of the advanced TODS sign must be approved by the department.

(10) Locations for TODS signs shall be approved by the department. As determined by the department, the signs shall be located so as to have the least impact on the scenic environment and must avoid conflict with other signs within the highway right-of-way. Mounting height and lateral offset shall be as specified in the MUTCD, department standards and this policy.

(11) TODS signs shall be displayed as designated in the MUTCD, the administrative rule for the TODS program and this policy.

(12) When an intersection leg is ineligible for the TODS Program due to the administrative rule for the TODS program, other intersection legs at that same intersection may remain eligible for the program.

(13) The design, arrangement, size, and location of TODS signs, including advance signs and trailblazer signs shall conform to the applicable specification contained in the MUTCD, the administrative rule for the TODS program and this policy.

(14) TODS signs shall be located a minimum of two hundred (200) feet in advance of the intersection and be spaced a minimum of two hundred (200) feet from other TODS signs or any other commission signs or traffic control devices.

(15) Advanced TODS signs shall be approximately one half (1/2) mile in advance of the intersection and a minimum of five hundred (500) feet from any other commission sign or traffic control device.

(16) When more than one (1) signs are installed on an assembly, the TODS signs shall be placed in following order from the top of the assembly to the bottom:

(A) Straight-through;

(B) Left turn;

(C) Right turn; and

(D) If more than one (1) qualified entity is located in the same direction from the intersection, the priority for that directional movement is to place the closest qualified entity's TODS sign first and the farthest last from top to bottom.

(17) TODS signs for left turns, right turns, and straight-through destinations should be on separate TODS assemblies if there are more than three (3) TODS signs on an approach to an intersection. If there are more than three (3) TODS sign destinations on an approach to an intersection the left turn and right turn destinations may be combined onto one (1) TODS assembly and the straight-through destination(s) shall be on a second assembly.

## ATTACHMENT - B

(18) When more than one (1) TODS assembly is installed in advanced of an intersection the assemblies shall be installed in the following order as seen in the direction of travel:

- (A) Assemblies displaying destinations to the left;
- (B) Assemblies displaying destinations to the right; and
- (C) Assemblies displaying destinations ahead.

(19) TODS signing for straight-through or ahead destinations shall only be permitted if there are similar TODS destinations to the right and/or left at the same intersection.

(20) TODS signs shall be six (6) foot wide by two (2) foot tall panels with a maximum of two (2) lines of white legend on a blue background. The legend shall be uppercase and a minimum of six (6) inches in height. Each TODS sign shall only include the name of one (1) destination, the mileage to the destination displayed below the directional arrow. The legend shall not include promotional advertising or services offered at the site with the exception of alternate fuel availability. The name or legend on the TODS sign should clearly convey what the eligible entity offers.

(21) Advanced TODS signs have the same design as a TODS signs with the omission of the mileage and directional arrow.

(22) A maximum of one (1) standard general service symbols or symbol for recreational and cultural interest areas found in the MUTCD may be displayed on TODS signs to the left of the sign legend. The symbol shall not be included if it results in the legibility of the text being compromised or compressed.

(23) A Logo panel may be displayed on a TODS sign as a replacement for text name of the qualified entity. If a Logo panel is used, up to two (2) standard general service symbols may be displayed along with the Logo panel. Hours of operation may be displayed on TODS along with a Logo panel with prior approval by the department.

(24) Where space is limited on an intersection approach leg to install TODS signing, preference shall be given to a qualified entity in the left and/or right directions over a destination in the ahead direction. If space is available for an ahead direction and a qualified entity in the left or right direction wishes to participate in the program at a later date, the ahead destination will lose its position when its annual participation agreement expires.

### **Policy for LOGO Signing**

(1) Logo signing is only eligible to be placed on right-of-way owned and maintained by the commission unless otherwise specified in this policy.

(2) No more than four (4) Logo signs shall be erected per exit direction.

## ATTACHMENT - B

(3) Only ground mounted Logo signs will be permitted. Logo signs shall not be installed on overhead sign structures or bridges. If there is insufficient ground space to accommodate the placement of the Logo sign without interfering or conflicting with other commission highway signing, the commission has the right to deny the request for logo signing.

(4) A Logo sign may display more than one (1) service type, but can only be subdivided into increments of two (2), four (4), or six (6) types if more than four (4) services are available and there are already four (4) specific panels that already exist at an interchange.

(5) Only six (6) logo panels for gas, food, lodging, camping, tourist attractions, and/or twenty-four (24) hour pharmacies will be displayed on a single Logo sign. If conditions exist at an interchange where there are less than six (6) qualified entities available or interested in participating in the Logo Program, or if there are more than six (6) qualified businesses of one service category, the placement of logo panels on specific service signs may be arranged as follows:

(A) When two (2) types of motorist services are combined on a single specific service sign, a maximum of four (4) logo panels may be displayed from one (1) of the two (2) motorist services represented on the combination specific service sign.

(B) When three (3) types of motorist services are combined on a single specific service sign, a maximum of two (2) logo panels may be displayed for each of the three (3) motorist services.

(C) When more than six (6) qualified entities of the same motorist service type wish to participate in the Logo Program at the same interchange, up to six (6) logo panels for this motorist service type may be installed, or roll over, onto a second specific service sign if the second specific service sign is empty or can be subdivided as stated above. No more than twelve (12) logo panels for one type of motorist service shall be displayed at a single interchange on a maximum of two (2) specific service signs. When more than six services of the same type exist on more than one service sign, the qualified entities occupying space on the second specific service sign may remain in place until such time as the space is needed by other qualified entities of other motor service types not currently displayed at the interchange choose to participate in the Logo Program at that interchange. When this occurs, the qualified entities which rolled over onto the second specific service will remain in place until their participation agreement expires.

(6) Any mainline, ramp, or trailblazer sign that is damaged or destroyed shall be repaired or replaced by the program manager within two (2) weeks after the program manager is made aware of the damage. Longer periods of time for repairs must be approved by the department. If a logo panel is destroyed the cost to replace it will be the responsibility of the applicant.

(7) The logo panel for a campground or tourist attraction shall be covered or removed and subsequently reinstalled if the campground or tourist attraction is closed during the winter or off season months.

## ATTACHMENT - B

(8) The location of mainline, ramp, and trailblazer logo signs shall be approved by the department. As determined by the department, the signs shall be located so as to have the least impact on the scenic environment and must avoid conflict with other signs within the highway right-of-way. Mounting height and lateral offset shall be as specified in the MUTCD, department standards, and this policy.

(9) Logo signs shall be displayed as designated in the MUTCD, the administrative rule for the Logo program and this policy.

(10) Logo signs shall not be erected at an interchange where an exit ramp is provided but no convenient reentry ramp exists in the same direction of travel.

(11) Logo signs shall not be erected at interchanges where the interchange ramps connect directly to another freeway.

(12) Logo signs shall not be erected at an interchange where one (1) exit ramp splits into two (2) or more ramps before connecting to the cross road.

(13) Logo signs shall not be erected in an area where there is less than three-quarters (3/4) of a mile between interchange gore points when measured in one (1) direction or as approved by the department. The exact location of the mainline logo sign shall be approved by the department before installation.

(14) Mainline logo signs shall be constructed and installed as follows:

(A) Mainline logo signs shall be spaced a minimum of eight hundred feet (800'), or as approved by the department, between successive mainline logo signs or any other department sign.

(B) Initial mainline logo signs should be installed in the order of pharmacy, tourist attraction, camping, lodging, food, and gas, as observed in the direction of travel.

(C) When mainline logo signs are erected on freeways with exit numbers the appropriate exit number for that interchange shall be displayed in place of the directional legend (for example, EXIT 10 instead of NEXT RIGHT).

(D) The initial logo panel arrangement should be placed on a mainline sign having two (2) rows of logo panels in order of increasing distance as follows: closest, upper left; second, lower left; third, upper center; fourth, lower center; fifth, upper right; sixth, lower right. On mainline signs with a single row of logo panels, individual logo panels should be placed in order of increasing distance from left to right. Relative distance of each qualified entity from the interchange shall be determined as previously described at the time of application.

(E) Mainline signs shall be constructed and installed in accordance with department standards and the MUTCD.

## ATTACHMENT - B

- (F) Any mainline sign designs not matching state and MUTCD standards shall be approved by the department prior to installation.
- (G) Logo panel size, including any border, shall be as specified in the MUTCD except that mainline logo panels will be forty-eight inches by thirty-six inches (48" × 36");
- (H) Mainline signs shall be maintained to meet or exceed federal minimum levels of retroreflectivity as specified in the MUTCD.
- (15) Ramp signs must be constructed and installed as follows:
- (A) Ramp signs shall be located on the department highway right-of-way along the freeway interchange ramp after the gore and before the ramp terminal. The exact location of the ramp sign shall be approved by the department;
- (B) Ramp signs shall be erected a minimum of one hundred feet (100'), or as approved by the department, between successive ramp signs or any other department sign on the ramp;
- (C) Ramp signs shall be installed in the same order as the mainline signs, in the order of pharmacy, camping, lodging, food and gas, as observed in the direction of travel;
- (D) Ramp signs shall be constructed and installed in accordance with department standards and the MUTCD;
- (E) Distance plates shall be installed below each logo panel on the ramp signs showing distance to the nearest one-quarter (1/4) mile. Direction arrows shall be used to indicate the direction motorists need to turn at the ramp terminal in order to reach the qualified entity they are seeking;
- (F) The order for logo panels on ramp signs will be determined by the direction of the arrow associated with each panel. Logo panels shall be ordered from top to bottom starting with the ahead movement on top, followed by the left movement with the right movement at the bottom. If space allows, preference is for the left movement logo panels to be oriented to the left of the ramp sign and right movement logo panels to the right of the ramp sign or trailblazer array;
- (G) Any ramp sign designs not matching department and MUTCD standards shall be approved by the department prior to installation; and
- (H) Logo panel size, including any border, shall be as specified in the MUTCD except that ramp logo panels twenty four inches by eighteen inches (24" x 18");
- (I) Ramp signs shall be maintained to meet or exceed federal minimum levels of retroreflectivity as specified in the MUTCD.

## ATTACHMENT - B

(16) Trailblazer signs must be constructed and installed as follows:

(A) Trailblazer signs shall be located on the commission's right-of-way at all intersections where the direction of the route changes or where it might be questionable as to which roadway to follow. Trailblazer signs should not be installed if the business is visible and recognizable from the public highway.

(B) The exact location of trailblazer signs shall be approved by the department. Where a trailblazer sign is required to be installed on a city or county road to provide proper guidance to the qualified entity, prior approval from the appropriate local government agency allowing the program manager to erect the trailblazer sign must be obtained. If these required trailblazer signs are not allowed to be installed on city or county routes it will result in that business to no longer be qualified to participate in the Program.

(C) Trailblazer signs shall be erected in the same order as the mainline and ramp logo signs in the order of pharmacy, camping, lodging, food, and gas when observed in the direction of travel.

(D) Trailblazer signs shall indicate, with the use of an arrow plaque below the logo panel, the direction to the qualified entity.

(E) Trailblazer signs shall be erected on steel or wood posts with mounting height and sign spacing to be in accordance with the latest edition of the Manual on Uniform Traffic Control Devices and be constructed and installed in accordance with department standards and the MUTCD.

(F) The order of logo panels on trailblazer arrays will be determined by the direction of the arrow associated with each logo panel. Logo panels shall be ordered in the array so left logo panels are on the left, ahead logo panels are in the middle and right logo panels are on the right of the array. If multiple directions are installed on the same post, the order of direction shall be from top to bottom: ahead movement, left movement, then the right movement at the bottom.

(G) Any trailblazer sign designs not matching state and MUTCD standards shall be approved by the department prior to installation.

(H) Logo panel size, including any border, shall be as specified in the MUTCD except that trailblazer logo panels will be twenty four inches by eighteen inches (24" x 18");

(I) Trailblazer signs shall be maintained to meet or exceed federal minimum levels of retroreflectivity as specified in the MUTCD.

(17) Logo Panels must be constructed and installed as follows:

(A) The logo panel shall have legend and background colors which provide adequate contrast between each other to maximize legibility, a white or light colored legend or a

## **ATTACHMENT - B**

dark colored background or a dark legend on a light or white colored background. Colors consistent with consumer awareness may be used with nationally, regionally, or locally known symbols or trademarks as long as an appropriately contrasting background color is selected to maximize legibility. The principal legend on the logo panel shall be a minimum of four inches (4") in height on ramp and trailblazer panels and ten inches (10") in height on mainline logo panels. When a symbol or trademark is used alone for the logo panel, any legend on the symbol or trademark shall be proportioned to the size. When symbols or trademarks are used alone with no additional text, the border may be omitted; and

(B) The logo panel shall be constructed and installed in accordance with department standards and the MUTCD.

(C) The logo panels shall be maintained to meet or exceed federal minimum levels of retroreflectivity as specified in the MUTCD.

(18) Combination mainline and ramp signs may be allowed as approved by the department.

### **Policy for Traffic Generators**

(1) Any non-conforming outdoor advertising for the traffic generator shall be removed before the qualified entity will be permitted to participate in the traffic generator program. Existence of non-conforming outdoor advertising prior to or erected after the installation of the traffic generator sign will void the participation agreement and the traffic generator signs will be removed unless the issue is corrected.

(2) A traffic generator shall enter into a participation agreement with the program manager. In doing so the traffic generator agrees to the terms and conditions of the rules of the program and understands that the fees paid only allows participation in the program and in no way gives them ownership of the signs. The signs and all materials associated with the installation shall remain the property of the commission.

# ATTACHMENT - C

POST NOM. SIZE	TORQUE AND HIGH STRENGTH BOLTS	BASE CONNECTION DATA TABLE (IN.)												
1	2	3	4	5	6	A	B	C	D	E	F	G	H	I
1	W8x9	3/4" ROUND	5	2	1 1/2	2 1/2	1 1/2	1 1/2	1 1/2	1 1/2	1 1/2	1 1/2	1 1/2	1 1/2
2	W8x13	3/4" ROUND	5	2	1 1/2	2 1/2	1 1/2	1 1/2	1 1/2	1 1/2	1 1/2	1 1/2	1 1/2	1 1/2
3	W8x18	3/4" ROUND	5	2	1 1/2	2 1/2	1 1/2	1 1/2	1 1/2	1 1/2	1 1/2	1 1/2	1 1/2	1 1/2
4	W10x22	3/4" ROUND	5	2	1 1/2	2 1/2	1 1/2	1 1/2	1 1/2	1 1/2	1 1/2	1 1/2	1 1/2	1 1/2
5	W10x26	3/4" ROUND	5	2	1 1/2	2 1/2	1 1/2	1 1/2	1 1/2	1 1/2	1 1/2	1 1/2	1 1/2	1 1/2
6	W12x35	3/4" ROUND	5	2	1 1/2	2 1/2	1 1/2	1 1/2	1 1/2	1 1/2	1 1/2	1 1/2	1 1/2	1 1/2

POST NOM. SIZE	WEIGHT (LB/LIN)	STUB LENGTH	FOOTING							
			LEVEL	4:1 GRADE	4:1 GRADE	3:1 OR 2:1 GRADE	3:1 OR 2:1 GRADE			
1	9.0	0-15	3'-0"	0-14	3'-2"	0-15	3'-3"	0-14	3'-6"	0-17
2	13.0	1-25	4'-0"	0-17	4'-2"	0-50	4'-3"	0-51	4'-6"	0-54
3	18.0	1-50	4'-6"	0-28	4'-8"	0-23	4'-9"	0-24	5'-0"	0-28
4	22.0	1-83	5'-0"	1-31	5'-2"	1-36	5'-3"	1-39	5'-6"	1-45
5	26.0	2-17	5'-0"	1-31	5'-3"	1-37	5'-5"	1-43	5'-9"	1-52
6	35.0	2-92	5'-6"	1-44	5'-9"	1-52	5'-11"	1-58	6'-3"	1-65

POST METAL NOT REQUIRED, CUT FROM 30 MIN. BEFORE INSTALLATION. ALL POSTS SHALL BE GALVANIZED TO MEET THE REQUIREMENTS OF ASTM A 653 OR A 659. ALL BOLTS SHALL BE GALVANIZED TO MEET THE REQUIREMENTS OF ASTM A 307. SEE SECTION C FOR BOLTS TO BE USED IN CONCRETE.

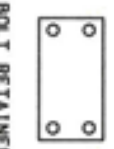

FOR POST SECTIONS NUMBERS 3, 4, 5 AND 6 HAVING WIDTHS GREATER THAN 18.0 IN., POSTS SHALL BE SPACED AT LEAST 7" APART. FOR POST SECTIONS NUMBERS 1 AND 2, POSTS MAY BE SPACED LESS THAN 7" APART, DO NOT USE THREE NUMBER 1 OR 2 POSTS WITH A SIGN WIDTH OF LESS THAN 10'-6".

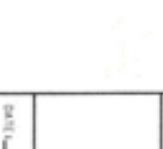
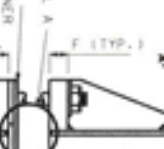
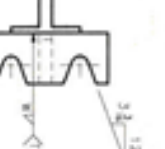
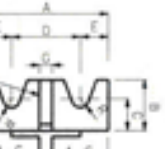
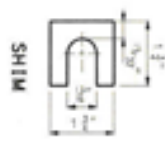

**GENERAL NOTES:**  
 DESIGN SPEC. ASHITO STANDARD SPECIFICATIONS FOR STRUCTURAL STEEL FOR HIGHWAY SIGNPOSTS AND TRAFFIC SIGNALS - 1985 (EXCEPT 2001 AND LATEST INTERIMS FOR STRUCTURAL STEEL POSTS).  
 POSTS, PERMANENT FUSE PLATE AND SPICE PLATE TO BE GALVANIZED AFTER FABRICATION.  
 METAL PROJECTING BEYOND THE PLANE OF THE PLATE FACE WILL NOT BE ALLOWED.  
 REMOVE ALL GALVANIZING RUNS OR BEADS IN THE WASHER AREA.  
 ALL STRUCTURAL STEEL STIFFENER PLATES AND BASE PLATES - FOR GROUND MOUNTED SIGNS SHALL MEET THE REQUIREMENTS OF ASTM A 36 OR ASHITO W 210 GRADE 50, MINIMUM YIELD 50,000 PSI.  
 IN THE EVENT THE DISTANCE BETWEEN THE TOP OF THE FOOTING AND THE BOTTOM OF THE SIGN IS LESS THAN 7'-9", THE SIGN HEIGHT AND POST LENGTH IS TO BE INCREASED SUFFICIENTLY TO ACCOMMODATE THIS MINIMUM SPACING.  
 HINGE PLATES NOT REQUIRED ON SINGLE POST SIGNS OR ANY SIGNS USING PIPE POSTS.  
 NUTS ON HINGE PLATE BOLTS SHALL BE TIGHTENED TO THE REQUIRED MINIMUM BOLTING VALUES SHOWN IN TABLE 1 SECTION OF THE STANDARD SPECIFICATIONS.  
 THE NUT SHALL BE FREE RUNNING, IF THE NUT WILL NOT SPIN ON THE BOLT BECAUSE OF GALVANIZING OR OXIDATION, LUBRICANTS SHALL BE APPLIED.  
 ALL BREAKAWAY ASSEMBLY BOLTS SHALL BE TIGHTENED IN A SYSTEMATIC MANNER TO THE PRESCRIBED TORQUE SHOWN ON THIS DRAWING.  
 EACH BREAKAWAY ASSEMBLY BOLT SHALL BE LOOSENED AND RE-TIGHTENED TO THE REQUIRED TORQUE IN THE SAME ORDER AS THE INITIAL TIGHTENING.  
 THE THEREAFTERS SHALL BE BURNED AT THE NUT USING A CENTER PUNCH TO PREVENT NUT FROM LOOSENING.  
 POST LENGTH QUANTITIES SHOWN ON PLANS INCLUDES STUB, 1" X 2 1/2" HIGH STRENGTH BOLTS FOR PIPE POSTS SHALL BE OF THE DESIGNATION ASHITO W 164 OR ASTM A 499. ALL OTHER H.S. BOLTS SHALL BE OF THE DESIGNATION ASHITO W 164.  
 FINISHES TWO .012" AND TWO .0012" THICK SHIMS PER POST FROM BRASS SHIM STOCK OR STEEL, DESIGNATION ASTM B 36. SHIMS AS REQUIRED TO PLUMB POST.  
 HIGH STRENGTH BOLTS WITH HEX NUT AND THREE WASHERS WITH EACH BOLT ARE TO BE GALVANIZED.  
 OPTIONAL HOLES 1/2" ROUND FOR 1" SHARP POSTS AND 3/4" ROUND FOR PIPE POST BASE PLATES AS SHOWN IN "ELEVATIONS" ARE TO BE USED AS AID FOR GALVANIZING ONLY.

**MISSOURI HIGHWAYS AND TRANSPORTATION COMMISSION**

**SIGN MOUNTING DETAILS**  
**BREAKAWAY ASSEMBLIES FOR**  
**GROUND MOUNTED SIGNS**

DATE: \_\_\_\_\_ EFFECTIVE: 10-01-2008 **903.03BF** 1

# ATTACHMENT - C

POST DES. NO.	NON. SIZE (IN.)	WEIGHT		DEPTH (IN.)	FLANGE		WEB THICK (IN.)
		LB/FT	LB/IN		WIDTH (IN.)	THICK (IN.)	
1	W6	9	0.75	9 1/2	4	4	4
2	W6	15	1.25	6	6	1	1
3	W8	18	1.50	8 1/2	5 1/2	1	1
4	W10	22	1.83	10 1/2	5 1/2	1	1
5	W10	26	2.17	10 1/2	5 1/2	1	1
6	W12	35	2.92	12 1/2	6 1/2	1	1

THE WEIGHT OF STRUCTURAL STEEL POSTS SHOWN IN THE CONTRACT HAS BEEN COMPUTED USING THE WEIGHTS SHOWN.

POST DESIGN NO.	F (IN.)	G (IN.)	H (IN.)	J (IN.)	K (IN.)	L (IN.)	M (IN.)	N (IN.)	Q1 (IN.)	Q2 (IN.)	P (IN.)	ROD 1 (IN.)	RT 1 (LB.)
1	4 1/2	1	1 1/2	4	2 1/2	1	1	1	2	2	1	1	0.76
2	5	1 1/2	1 1/2	6	3 1/2	1 1/2	1	1	1 1/2	1 1/2	1	1	1.67
3	5	1 1/2	1 1/2	5 1/2	2 1/2	1 1/2	1	1	1 1/2	1 1/2	1	1	1.51
4	6	1 1/2	1 1/2	5 1/2	2 1/2	1 1/2	1 1/2	1 1/2	1 1/2	1 1/2	1	1	2.52
5	6	1 1/2	1 1/2	5 1/2	2 1/2	1 1/2	1 1/2	1 1/2	1 1/2	1 1/2	1	1	2.52
6	6	1 1/2	1 1/2	6 1/2	3 1/2	1 1/2	1 1/2	1 1/2	1 1/2	1 1/2	1	1	3.35

POST DESIGN NO.	J (IN.)	K (IN.)	L (IN.)	U (IN.)	Q1 (IN.)	Q2 (IN.)	ROD 1 (IN.)	RT 1 (LB.)
1	4	2 1/2	1	1	1	1	1	2.45
2	6	3 1/2	1 1/2	1	1 1/2	1 1/2	1	4.89
3	5 1/2	2 1/2	1 1/2	1	1 1/2	1 1/2	1	5.32
4	5 1/2	2 1/2	1 1/2	1	1 1/2	1 1/2	1	5.75
5	5 1/2	2 1/2	1 1/2	1	1 1/2	1 1/2	1	5.04
6	6 1/2	3 1/2	1 1/2	1	1 1/2	1 1/2	1	10.47

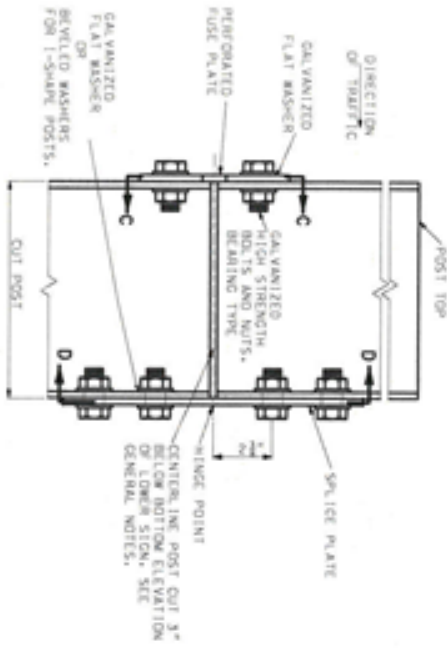

**ELEVATION**  
**PERFORATED FUSE PLATE AND SPLICE PLATE DETAIL**

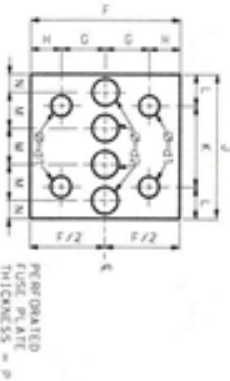

**ELEVATION C-C**

ALL HOLES SHALL BE DRILLED. ALL PLATE CUTS SHALL PERFORMED BY BE SAW CUTS. HORIZONTAL FLAME CUTTING WILL BE PERMITTED PROVIDED ALL EDGES ARE CHAMFERED.  
PERFORATED FUSE PLATE AND SPLICE PLATE SHALL BE FABRICATED FROM ASTM A 36 STRUCTURAL STEEL.

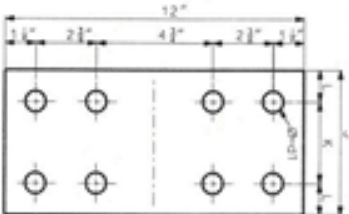

**ELEVATION D-D**

SPLICE PLATE THICKNESS = U

**GENERAL NOTE**

FOR ROADWAYS WHERE TRAFFIC MAY STRIKE THE BACKSIDE OF THE POST, PERFORATED FUSE PLATES SHALL BE INSTALLED ON BOTH SIDES OF THE POST.

MISSOURI HIGHWAYS AND TRANSPORTATION COMMISSION

**SIGN MOUNTING DETAILS**  
**BREAKAWAY ASSEMBLIES FOR**  
**GROUND MOUNTED SIGNS**

DATE: \_\_\_\_\_ EFFECTIVE: 10-01-2004

**903.03BF**

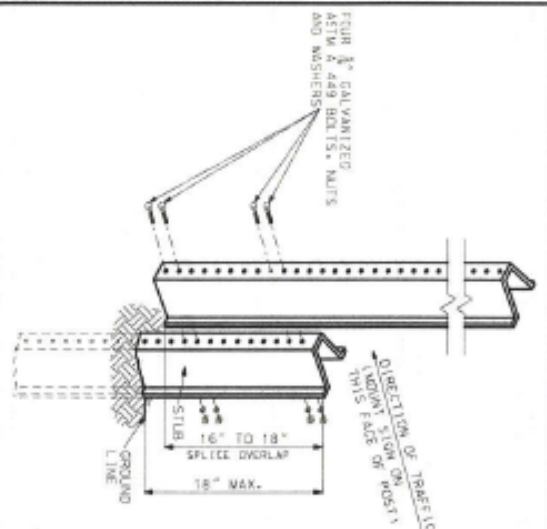

**U-CHANNEL POST DETAIL  
PERMANENT AND TEMPORARY INSTALLATION**

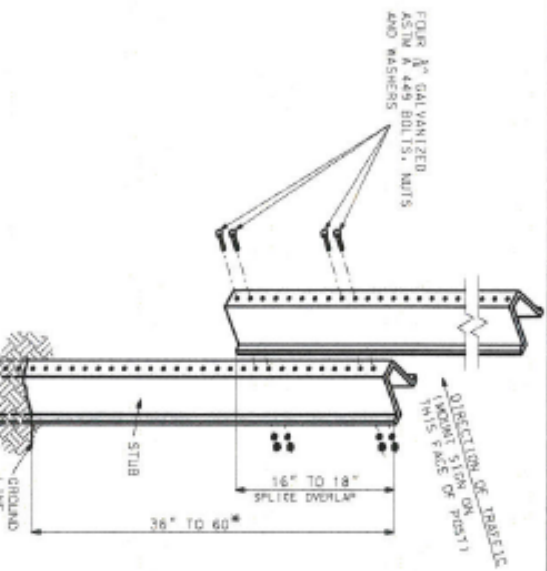

**OPTIONAL U-CHANNEL POST DETAIL  
TEMPORARY INSTALLATION ONLY**

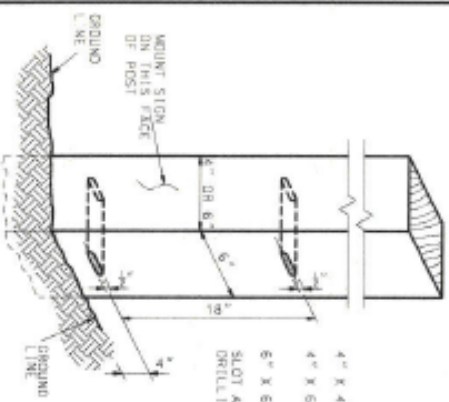

**WOOD POST DETAIL**

4" x 4" WOOD POST - NO SLOTS OR HOLES REQUIRED  
 4" x 6" WOOD POST - 1 1/2" x 1/2" SLOT ON 6" SIDE OR 1 1/2" DIA. HOLE ON 6" SIDE  
 6" x 6" WOOD POST - 2" x 2" x 3/4" SLOT OR 2" DIA. HOLE  
 SLOT ACROSS NEUTRAL AXIS FORMED BY SUCCESSIVE DRILLING WITH 3/4" BIT.

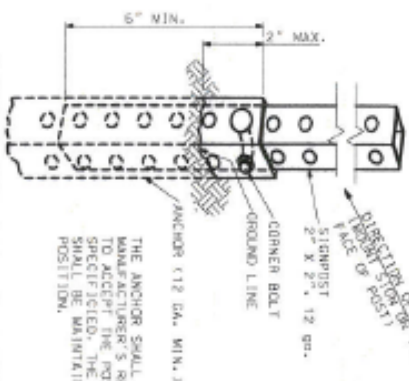

**PERFORATED SQUARE STEEL  
TUBE POST DETAIL**

ANCHOR (1/2 DIA. MIN.)  
 CORNER BOLT  
 STOPPOST  
 2" x 2" x 1/2 ga.  
 2" MAX.  
 6" MIN.  
 THE ANCHOR SHALL BE SIZED AS PER MANUFACTURER'S RECOMMENDATIONS TO ACCEPT THE POST SIZE SPECIFIED. THE SIGN ASSEMBLY SHALL BE MAINTAINED IN A PLUMB POSITION.

POST TYPE	WOOD	PERFORATED SQUARE STEEL TUBING
SIGN AREA 150. FT. <sup>2</sup>	U-CHANNEL	
≤ 10	1 - 3.0 LB./FT.*	1 - 4" x 4" #
> 10 ≤ 16	2 - 3.0 LB./FT.	2 - 4" x 4" #
> 16 ≤ 24	2 - 3.0 LB./FT.	1 - 4" x 6" #
> 24 ≤ 30	3 - 3.0 LB./FT.	2 - 4" x 6" #
> 30 ≤ 50	N/A	3 - 2" x 12 GA. #
		N/A

\* SIGN GREATER THAN 4 FEET IN WIDTH, EXCEPT DIAGONAL SHAPE SIGNS, REQUIRE TWO POSTS.  
 \*\* REQUIRES SLIP BASE PER MANUFACTURER'S RECOMMENDATION.  
**POST SIZE REQUIREMENTS**

USE OF SPLICE IS OPTIONAL.  
 PERMANENT AND TEMPORARY INSTALLATIONS: SPLICE OVERLAP SHALL BE POSITIONED ENTIRELY BETWEEN GROUND LINE AND 18" ABOVE GROUND LINE.  
 OPTIONAL TEMPORARY INSTALLATIONS: SPLICE OVERLAP MAY BE POSITIONED BETWEEN 18" AND 60" ABOVE GROUND LINE.  
 \* IF A PLAQUE IS USED, NEITHER THE SIGN NOR PLAQUE SHALL BE POSITIONED WITH THE SPLICE OVERLAP.  
 ONLY ONE SPLICE WILL BE ALLOWED PER POST.

THE STOPPOST SHALL BE ATTACHED TO THE ANCHOR WITH THE CORNER BOLT PER MANUFACTURER'S SPECIFICATION. PERMANENT AND TEMPORARY INSTALLATIONS: SPLICE OVERLAP SHALL BE POSITIONED ENTIRELY BETWEEN GROUND LINE AND 18" ABOVE GROUND LINE.  
 OPTIONAL TEMPORARY INSTALLATIONS: SPLICE OVERLAP MAY BE POSITIONED BETWEEN 18" AND 60" ABOVE GROUND LINE.  
 \* IF A PLAQUE IS USED, NEITHER THE SIGN NOR PLAQUE SHALL BE POSITIONED WITH THE SPLICE OVERLAP.  
 THE SPLICE SHALL CONSIST OF A 1/2 INCH PIECE OF 1 1/2 INCH TUBE, INSERTED 6" INTO BOTH THE UPPER AND LOWER STOPPOST SECTIONS AND CORNER-BOLTED AT BOTH ENDS.

**GENERAL NOTES:**  
 ALL POSTS SHALL BE EMBEDDED A MINIMUM OF 3 FEET.  
 MISKANT HIGHWAYS AND TRANSPORTATION COMMISSION

<b>HIGHWAY SIGNING POST MOUNTING DETAILS</b>	
DATE: _____	903.03BF
PROJECTIVE: 16-01-2009	3
	14

# ATTACHMENT - C

**ROUND PIPE POST FOR GROUND MOUNTED SIGNS**

NOMINAL SIZE (IN.)	BOLT DATA	BASE CONNECTION DATA								
		A	B	C	H	T	W			
2 1/2	A 3	3	3 1/2	140	6 1/2	9	1 1/4	1	1	1
4	B	3 1/2	3 1/2	245	7 1/2	10	1 1/2	1	1	1

**ROUND PIPE POST AND FOOTING DATA TABLE**

NOM. SIZE (IN.)	WEIGHT (LBS/FT)	3/16" DIA. FOOTING CONCRETE	FOOTING DATA	
			DEPTH (IN.)	C.V.
2 1/2	5.79	0.48	4'-3 1/2"	12°
3	7.98	0.63	4'-3 1/2"	12°
4	10.79	0.90	5'-3 1/2"	18°

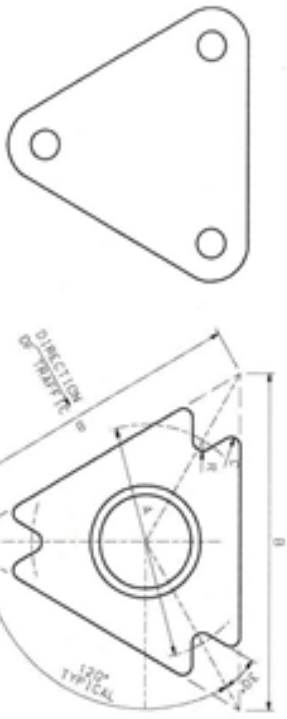

**BOLT RETAINER**

SHEET METAL BOLT RETAINER CUT FROM 30 GAUGE GALVANIZED SHEET METAL. PLACE BETWEEN BASE PLATES. SIZE VARIES TO FIT PLATE. BOLT HOLES SHALL BE 1/8" LARGER THAN REQUIRED BOLT SIZE.

**PLAN VIEW**

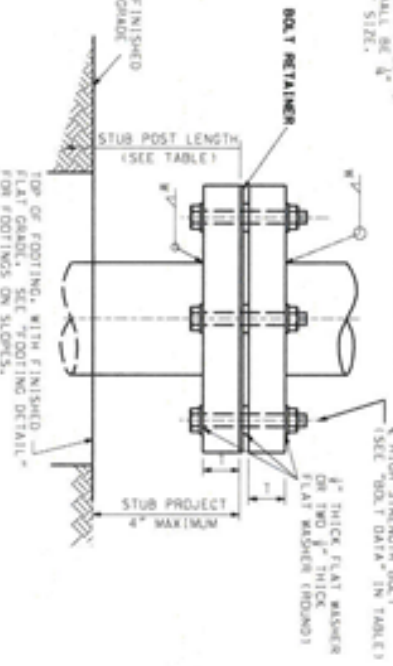

**ELEVATION MULTI-DIRECTION SLIP BASE**  
(STEEL PIPE POST BASE CONNECTION)

- 1 PIPE 3" DIA. AND UNDER
- 2 MAXIMUM IN ROCK
- 3 PIPE OVER 3" DIA. 1 MAXIMUM IN ROCK

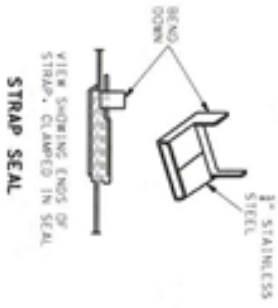

**STRAP SEAL**

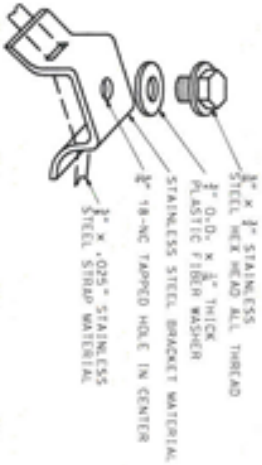

**FLARED LEG SIGN BRACKET**

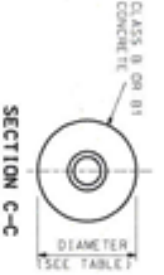

**SECTION C-C**

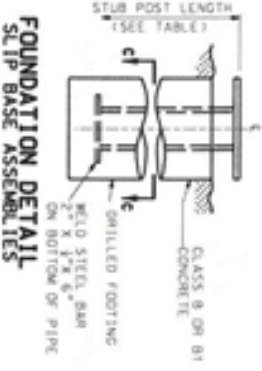

**FOUNDATION DETAIL SLIP BASE ASSEMBLY**

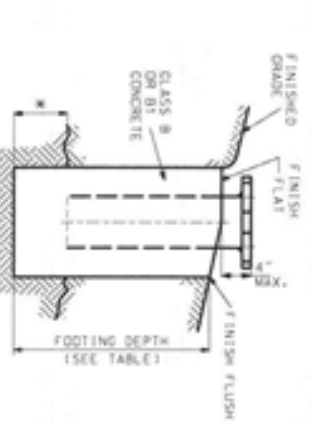

**FOOTING DETAIL**

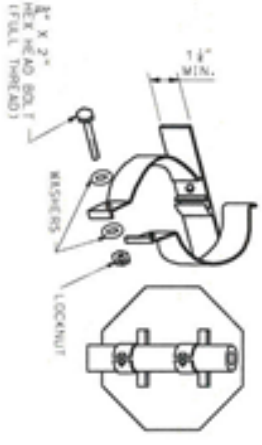

**STAINLESS STEEL HARDWARE CLAMP TYPE SIGN SUPPORTS FOR PIPE POST**

ROLLED CHUTE TO ENGAGE PIPE 0.0.

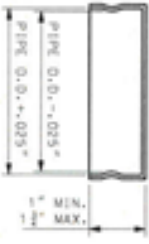

**FRICTION CAP**

GENERAL NOTE:  
REFER TO THE GENERAL NOTES ON SHEET 1.

MISSOURI HIGHWAYS AND TRANSPORTATION COMMISSION

<b>SIGN MOUNTING DETAILS</b>	
POST FOR SIGNS 50 SQUARE FEET OR SMALLER	
DATE: _____	903.03BF
EFFECTIVE: 10-01-2009	4 / 11

# ATTACHMENT - C

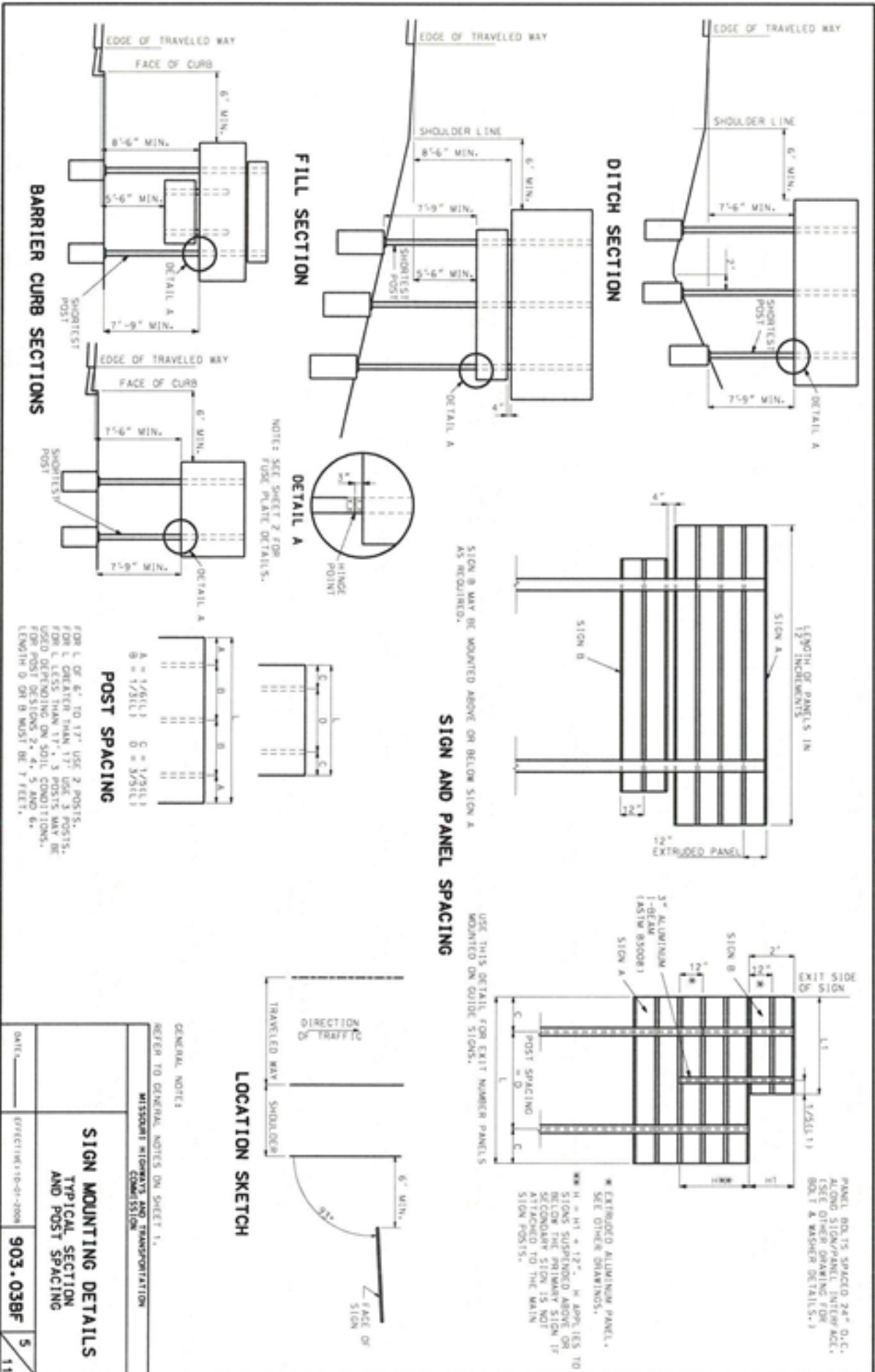



# ATTACHMENT - C

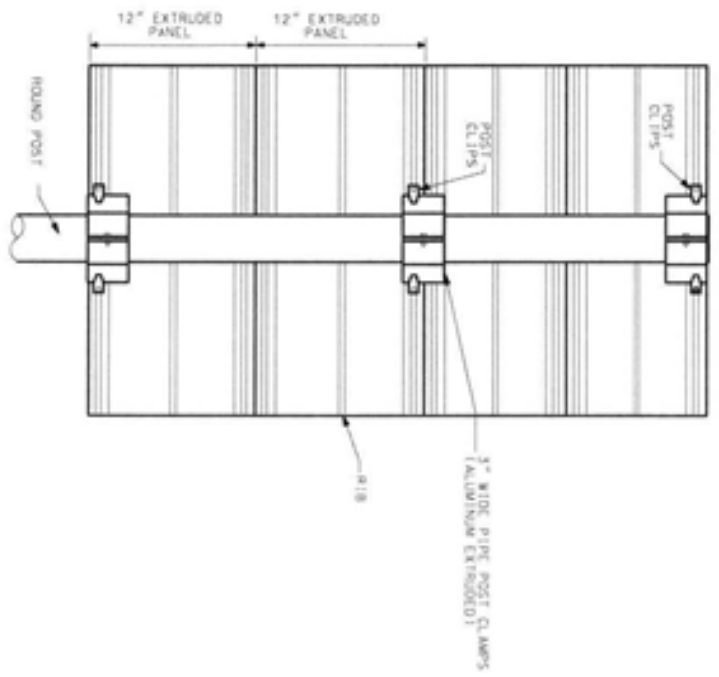
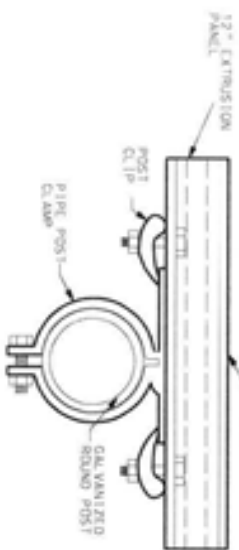
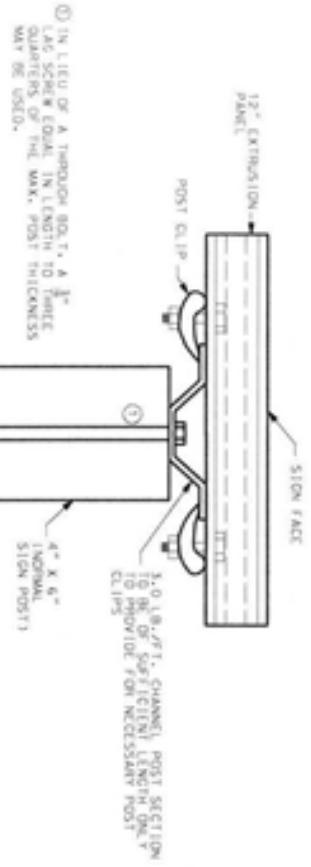

## MOUNTING DETAILS FOR EXTRUDED PANELS ON ROUND PIPE POST

NUMBER OF BOLTS TO ATTACH STEEL CHANNEL TO WOOD POST

SIGN HEIGHT	NO. OF BOLTS PER WOOD POST USED
1'	2
2'	3
3'	4
4'	5
5'	6
6'	7
7'	8

\*LAG SCREWS MAY BE SUBSTITUTED

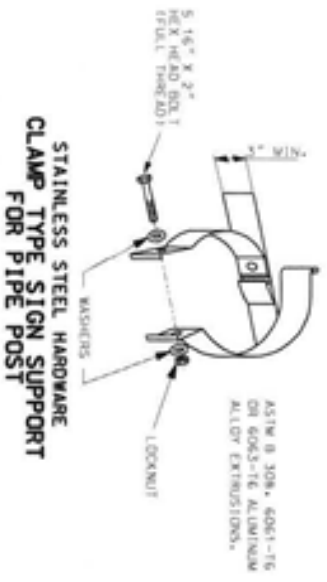

MISSOURI HIGHWAYS AND TRANSPORTATION COMMISSION	
<b>SIGN MOUNTING DETAILS</b> EXTRUDED PANEL ATTACHMENTS FOR SIGNS 30 SQ. FT. OR SMALLER	
DATE: _____	EFFECTIVE 10-01-2008
<b>903.03BF</b>	
11	11





# ATTACHMENT - D



## SECTION 903

### HIGHWAY SIGNING

**903.1 Description.** This work shall consist of furnishing and installing highway signs as shown on the plans. All signs shall be in accordance with the MUTCD. Any signs not detailed on the plans shall be in accordance with *Standard Highway Signs* by the U.S. Department of Transportation, Federal Highway Administration.

**903.2 Material.** All material shall be in accordance with Division 1000, Material Details, and specifically as follows:

Item	Section
Reinforcing Steel for Concrete	1036
Highway Sign Material	1042
Delineators, Mile and Marker Posts	1044
Paints for Structural Steel	1045
Electrical Conduit	1060
Expansive Mortars	1066
Low-Carbon Steel Bolts, Nuts and Washers	1080
Structural Carbon Steel	1080
Structural Low Alloy Steel	1080
Low-Carbon Steel Anchor Bolts	1080
High-Strength Bolts, Nuts and Washers	1080
Galvanized Coating of Structural Steel, Tubular Steel Sign Supports, Sign Trusses and Appurtenances	1081

#### 903.2.1 Sign Posts and Tubular Steel Sign Supports.

Item	Section/Specification
Wood Posts	1050
Steel Pipe Posts	ASTM A 53, Grade B, or ASTM A 500, Grade B
Galvanizing of Steel Pipe Posts	ASTM A 53
Structural Steel Welding Electrodes	AWS A5.1 or AWS A5.5
Structural Steel Posts	AASHTO M270 Grade 50 or 50w
U-Channel Posts	ASTM A 499, Grade 60

# ATTACHMENT - D

## 903.2.2 Overhead Sign Trusses.

Item	Specification
Aluminum Extruded Tube	ASTM B 221, 6061-T6
Aluminum Permanent Mold Castings	ASTM B 108, A 356.0-T61
Aluminum Sand Castings	ASTM B 26, 356.0-T6
Aluminum Plate	ASTM B 209, 6061-T6
Aluminum Structural Shapes	ASTM B 308, 6061-T6
Aluminum Pipe Handrail	ASTM B 241, 6061-T6 or 6063-T6
Aluminum Pipe Fittings for Schedule 10 Pipe	ASTM B 26, 356.0-T6 or ASTM B 108, A 356.0-T61
Aluminum Grating Bearing Bars	ASTM B 211, 6061-T6 or ASTM B 221, 6061-T6 or 6063-T6
Cross Bars	ASTM B 211, 6061-T6 or ASTM B 221, 6061-T6 or 6063-T5 or T6
Aluminum Washers	ASTM B 209, 2024-T4 or Alclad 2024T4
Aluminum Beveled Washers	ASTM B 221, 2024-T4
Filler Wire for Welding Aluminum	AWS A 5.10 ER5356, ER5556
Stainless Steel U-Bolts	ASTM A 276 Chromium-Nickel Grade, min. yield 30,000 psi
Stainless Steel Bolts, Nuts, Screws and Washers	ASTM A 320 or SAE J405D, Austenitic Steel, min. yield 30,000 psi
Structural Steel Welding Electrodes	AWS A 5.1 or AWS A 5.5

**903.2.3 Hardware.** Bolts, nuts and washers specified to be galvanized shall be galvanized in accordance with Sec 1081. Except for anchor bolts, galvanizing thickness shall not exceed 6 mils. For high strength bolts, the contractor shall furnish to the engineer a copy of the manufacturer's inspection test report for each production lot or shipping lot furnished, and shall certify the bolts furnished are in accordance with Sec 1080.

**903.2.4 Concrete.** Concrete shall be of the class specified in the contract. Material, proportioning, mixing, slump and transporting of concrete shall be in accordance with Sec 501 for the specific class specified. Concrete shall be placed, finished and cured in accordance with Sec 703. The entire exposed concrete surface, including sides and top, shall be surface sealed in accordance with Sec 703.

**903.2.5 Equipment and Material.** Equipment and material shall be of new stock unless the contract provides for relocation of existing units or use of units furnished by others. New equipment and material shall meet the approval of the engineer.

## 903.3 Construction Requirements.

### 903.3.1 Footings for Trusses and Posts.

**903.3.1.1 Bolt-Down Installations.** Class B concrete shall be used to construct all footings and end supports for overhead sign trusses, tubular steel sign supports and posts with bolt-down bases. Footings shall be formed, unless in the judgment of the engineer, soil conditions permit excavation to be made to the neat lines of the footings and the footings cast against the undisturbed vertical soil face. In all cases, the top 12 inches below finished ground line shall be formed. Footings shall be placed on firm, stable, undisturbed soil to the minimum depth shown on the plans. Backfill shall be thoroughly compacted, and care taken to prevent damage to finished concrete. Backfill shall be brought up level with the finished ground line.

# ATTACHMENT - D

Anchor bolts shall be firmly held in proper position, supported at the top, during placement of concrete.

**903.3.1.2 Embedded Installations.** Class B or B-1 concrete, or concrete of a commercial mixture meeting the requirements of Sec 501 shall be used for the footings for embedded-type sign posts. The contractor may use a quick-setting polyurethane foam for footings in lieu of concrete. The foam shall have a minimum compressive strength of 80 psi, in the direction of rise, when tested in accordance with ASTM D 1621, and shall have a minimum density of 4 pounds per cubic foot when tested in accordance with ASTM D 1622. Foam shall not be placed in water. Polyurethane foam shall be mixed in accordance with manufacturer's recommendations. Posts shall be supported in proper position until the concrete or foam has set. Excavation and backfill shall be in accordance with Sec 903.3.1.1, except forming will not be required unless soil conditions warrant forming. Polyurethane foam will not be permitted if forming is necessary. Tops of footings shall be finished flush with the slope of the ground to the satisfaction of the engineer.

**903.3.1.3 Optional Footings.** Substructures for butterfly and cantilever overhead sign trusses and posts may be either drilled shafts or spread footings.

**903.3.1.3.1** The quantities shown on the plans reflect the total cubic yards of substructure, based upon drilled shaft quantities.

**903.3.1.3.2** No adjustment in payment will be made for providing the equivalent spread footing design that differs in area from the specified drilled shaft design.

**903.3.1.3.3** If rock is encountered and the depth of drilled shafts are adjusted accordingly, cubic yard quantities will be recalculated for those locations and payment will be adjusted accordingly. Cubic yard quantities will not be recalculated for spread footings if rock is encountered, unless it is considered differing site conditions in accordance with Sec 104.2 of the standard specifications.

## **903.3.2 Posts for Ground Mounted Signs.**

**903.3.2.1 Post Lengths.** Post lengths shown on the plans for ground-mounted signs are for bidding purposes only. The contractor shall be responsible for determining post lengths to provide the vertical clearance shown on the plans. Field cutting of posts will be permitted.

**903.3.2.2 Post Alignment.** Sign posts shall be vertical. Any post bent or otherwise damaged to the extent that the post is considered unfit for use shall be removed and replaced with an acceptable post at the contractor's expense.

**903.3.2.2.1 Structural Steel Posts.** Structural steel sign posts for ground mounting of signs shall be fabricated and erected as shown on the plans. Welds shall be of full section and sound throughout. Posts with dimensional defects and structural discontinuities will be rejected. Posts built up by welding two lengths together will be permitted, provided the welds are ground smooth and flush with the base metal. Posts and appurtenances shall be hot-dip galvanized after fabrication. Posts with breakaway assemblies shall be cut at the hinge prior to galvanizing, except for field cutting. Hinge plates shall not be attached to the posts at the time of galvanizing. All welds shall be cleaned before galvanizing. All exposed steel areas and damaged galvanizing shall be repaired in accordance with Sec 1081.

**903.3.2.2.2 Pipe Posts.** Pipe posts shall be fabricated as shown on the plans and shall be hot-dip galvanized after fabrication. Welds shall be of full section and sound throughout. Posts with dimensional defects and structural discontinuities will be rejected. All welds shall be cleaned before galvanizing. Exposed steel areas and damaged galvanizing shall be repaired in

# ATTACHMENT - D

accordance with Sec 1081. Friction caps for pipe posts shall be of the dimensions shown on the plans and may be galvanized steel or aluminum alloy.

**903.3.2.2.3 Perforated Square Steel Tube Posts.** Perforated square steel tube posts shall be installed at locations shown on the plans. Exposed steel areas and damaged galvanizing shall be repaired in accordance with Sec 1081.

**903.3.2.2.4 U-Channel Posts.** U-Channel posts shall be installed at locations shown on the plans. Exposed steel areas and damaged galvanizing shall be repaired in accordance with Sec 1081.

**903.3.2.2.5 Wood Posts.** Wood posts shall be installed at locations shown on the plans.

**903.3.2.3 Certification.** The contractor shall furnish to the engineer three copies of the fabricator's certification that the material supplied is in accordance with the requirements specified.

**903.3.3 Tubular Steel Sign Supports.** Tubular sign supports for overhead mounting of signs shall include span, cantilever and butterfly types, complete with poles, beams, mast arms, sign bracket assemblies and other specified appurtenances. All steel shall be hot-dip galvanized after fabrication in accordance with Sec 1081. All welds shall be cleaned before galvanizing. Shop drawings will not be required for these supports.

**903.3.3.1 Tapered Steel Poles and Beams.** Tapered steel poles and beams shall be a continuous taper tube, fabricated from one length of open hearth sheet steel with one continuous welded longitudinal seam. After fabrication, the material shall have a minimum yield strength of 48,000 psi. Straight steel arms shall be standard or extra heavy pipe, of the dimensions and grades shown on the plans. Bolts, nuts, washers, clamps and sign bracket assemblies shall be hot-dip galvanized or of stainless steel. Clamps shall be fabricated of low alloy steel.

**903.3.3.2 Certification.** The contractor shall furnish to the engineer three copies of the manufacturer's certification that the tubular steel sign supports are in accordance with the requirements specified.

**903.3.3.3 Surfaces.** Galvanized material shall be handled to avoid damage to the surfaces. Any material on which the galvanizing has been bruised or broken will be rejected or may, with approval from the engineer, be repaired in accordance with Sec 1081.

**903.3.4 Overhead Sign Trusses.** Overhead sign trusses shall be steel or aluminum, and shall include all structural steel, structural aluminum, aluminum castings, pipe railing, gratings, supports and appurtenances above the top surface of the concrete footings. Shop drawings in accordance with Sec 1080 shall be furnished to the engineer for approval.

**903.3.4.1 Testing and Certification.** The contractor shall furnish to the engineer a copy of certified mill test reports on all material furnished, providing the actual chemical analysis and the actual results of physical tests. In lieu of mill test reports for secondary members, the contractor may furnish a certification from the fabricator certifying the material supplied is in accordance with the requirements of these specifications. All test reports and certifications shall be furnished to the engineer before any requests for shop inspection are made.

**903.3.4.2 Steel Fabrication and Erection.** Structural steel fabrication and erection shall be in accordance with Secs 712 and 1080, except as hereinafter specified.

# ATTACHMENT - D

**903.3.4.3 Welder Qualifications.** Before starting fabrication of structural aluminum, all welders shall be qualified in accordance with the latest edition of ANSI/AWS D1.2 – Structural Welding Code, Aluminum. The test specimens shall be made using a base metal of aluminum alloy 6061-T6 using filler metal acceptable for welding this alloy and inert gas shield arc. Requalification may be required any time there is specific reason to question the welder's ability.

**903.3.4.4 Welding Inspection.** All aluminum welds shall be inspected by the fabricator to verify the reliability of production as follows:

(a) Visual inspection of all welds, proof testing of welds, and sufficient destructive testing of weld samples fabricated during the production welding.

(b) Poor welding workmanship noted by visual inspection will be sufficient cause for rejection.

**903.3.4.5 Contact Surfaces.** Contact surfaces of aluminum flange castings shall be finished to provide at least 50 percent contact after assembly, as indicated by the Standard Machinist's Blue Test.

**903.3.4.6 Fabrication of Aluminum Alloy.** Fabrication of aluminum alloy material shall be in accordance with the manufacturer's recommendations and the following requirements. Flame cutting will not be permitted. All holes in castings shall be machined for final fit. Welding shall be done by the inert gas shielded arc method, and flux shall not be used. Precautions shall be taken to avoid scoring or marring of aluminum surfaces. The engineer will reject any scoring or marring that gives an objectionable appearance. Cast parts shall have all casting irregularities removed. Tubing shall be seamless, and exterior and interior surfaces shall be clean, smooth and free from slivers, laminations, grooves, cracks or other defects.

**903.3.4.7 Shop Inspection.** Shop inspection will be in accordance with Sec 1080.

**903.3.4.8 Wind Testing.** Simulated wind-shop test loading for aluminum trusses will be required as shown on the plans. The load in kips and location of the point of application shall be indicated on the shop drawings.

**903.3.4.9 Handling and Storage.** Handling and storage of material shall be in accordance with Sec 712. If specified, galvanized high strength bolts and washers shall be in accordance with Sec 903.2.2. Bolts shall be snugly tightened. Connections in which steel and aluminum are in contact shall be protected as shown on the plans.

**903.3.4.10 Surfaces.** Galvanized and aluminum material shall be handled to avoid damage to the surfaces. Any material on which the galvanizing has been bruised or broken will be rejected or may, with approval from the engineer, be repaired in accordance with Sec 1081.

## **903.3.5 Sign Storage, Certification and Erection.**

**903.3.5.1 Storage of Signs.** Signs delivered for use on a project shall be stored in a manner meeting the approval of the engineer. Any sign damaged, discolored or defaced during transportation, storage or erection may be rejected.

**903.3.5.2 Fabricator's Certification.** The contractor shall furnish to the engineer, prior to sign erection, the fabricator's certification stating, "I hereby certify that only material and manufacturing processes in full compliance with the Missouri Department of Transportation

# ATTACHMENT - D

job specification requirements were used in the fabrication of signs for Job \_\_\_\_\_,  
Route \_\_\_\_\_, County \_\_\_\_\_."

**903.3.5.3 Erection of Signs.** Sign posts shall be set vertically true to line such that the signs will be level, at the proper angle with the roadway, and with the minimum clearances shown on the plans. Mounted signs shall present a smooth flat surface varying no more than 3/8 inch from a 4-foot straightedge placed in any position on the face of the sign after erection. Signs on traffic signal posts shall be mounted with strap or clamp type sign supports as shown on the plans or as approved by the engineer. Signs shall not be mounted on light poles.

**903.3.6 Delineators.** Delineators shall be installed vertically and any delineator considered unfit for use by the engineer shall be removed and replaced at the contractor's expense.

**903.4 Final Clean Up.** Final clean up of right of way shall be in accordance with Sec 104.11.

**903.5 Method of Measurement.** Final measurement will not be made except for authorized changes during construction, or where appreciable errors are found in the contract quantity. The revision or correction will be computed and added to or deducted from the contract quantity. Where required, measurements will be made in the following manner.

**903.5.1** Measurement of concrete for footings, including all concrete, excavation, backfilling, reinforcing steel, anchor bolts and nuts, grout and other incidental items shown on the plans, will be made to the nearest 0.1 cubic yard.

**903.5.2** Measurement of the weight of structural steel and pipe posts will be made to the nearest pound for each post and to the nearest 10 pounds for the total, as shown on the plans. Weights will be computed using the theoretical weight of the various sections.

**903.5.3** Measurement of sign areas will be made to the nearest 1/10 square foot for each sign and to the nearest square foot for the total. The area of each sign will be that of the smallest rectangular, triangular or trapezoidal shape that will encompass the sign panel.

**903.5.4** Measurement of perforated square steel tube, u-channel and wood posts will be made to the nearest linear foot for each post, as shown on the plans.

**903.5.5** Measurement of delineators will be made per each.

## **903.6 Basis of Payment.**

**903.6.1** Breakaway assemblies, including the base connection, hinge plate and all other fabrication, complete in place, will be paid for at the contract unit price each, regardless of the post size or shape.

**903.6.2** Highway signing will be paid for at the contract unit price for each of the items included in the contract. No direct payment will be made for incidental items necessary to complete the work, unless specifically provided as a pay item in the contract.

**903.6.3** Delineator posts will be paid for at the contract unit price. No direct payment will be made for reflective sheeting or post anchors.

**903.6.4** Perforate square steel tube, u-channel and wood posts will be paid for at the contract unit price for each of the items included in the contract.

**903.6.5** Concrete footings will be paid for at the contract unit price.

## ATTACHMENT - D

**903.6.6** Structural steel and pipe posts will be paid for at the contract unit price for each of the items included in the contract.

# ATTACHMENT - D



## SECTION 1042

### HIGHWAY SIGN MATERIAL

**1042.1 Scope.** This specification covers the material used in signs and fastening devices, and the fabrication of signs.

**1042.2 Material.** Material shall be of new stock and shall be in accordance with the following, unless otherwise shown on the plans.

#### 1042.2.1 Signs.

Item	Specification
Aluminum Flat Sheets	ASTM B 209, 6061-T6 or 5052-H38
Aluminum Extruded Sign Panels	ASTM B221, 6063-T6

#### 1042.2.2 Sign Appurtenances.

Item	Specification
Aluminum Post Clip	ASTM B 108, 356-T6
Aluminum Bolts	ASTM B 211, 2024-T4 or 6061-T6
Aluminum Nuts	ASTM B 211, 2024-T4, 6061-T6, 6262-T9 or 2017-T4
Aluminum Flat Washers	ASTM B 209, or Alclad 2024-T4 or 2024-T4
Aluminum Lock Washers	ASTM B 211, 7075-T6
Aluminum Lock Nuts (Nylon Insert)	ASTM B 211, 2017-T4
Aluminum Edge Molding	ASTM B 221, 6063-T6
Stainless Steel Bolts, Nuts, Screws and Washers	ASTM A 320 or SAE J405D, Austenitic Steel, Min. Yield 30,000 psi

**1042.2.3 Certification.** A manufacturer or supplier's Certification of Metal used for signing material listed above shall be furnished to the engineer at the fabrication plant at the time of material inspection. The contractor shall furnish to the engineer the fabricator's certification in accordance with Sec 903.3.5.2.

**1042.2.4 Structural Signs.** Structural signs shall be fabricated of 0.081-inch minimum extruded aluminum panels and mounted as shown on the plans. The maximum allowable deviation from flatness shall not exceed 0.010 inch per inch width of the panel. Shop drawings for approval from the engineer will be required for any variation in the assembly or mounting details.

**1042.2.5 Sheet Signs.** Flat sheet signs shall be fabricated as shown on the plans from sheet aluminum of the specified thickness. Flat sheet signs shall not have holes except those drilled or punched for proper mounting.

**1042.2.6 Washers.** Nylon washers recommended by the sign sheeting manufacturer shall be used between the bolt heads and sign faces on flat sheet aluminum signs. The washers shall be

# ATTACHMENT - D

for use with 3/8-inch bolts and shall have a minimum outside diameter of 3/4 inch, and a nominal thickness of 1/16 inch.

**1042.2.7 Retroreflective Sheeting.** Retroreflective sheeting shall be in accordance with latest versions of ASTM D 4956 and AASHTO M 268, except as noted herein. Color and luminance values for all MoDOT types of reflective sheeting shall be in accordance with ASTM D 4956. Retroreflective sheeting shall have sufficient adhesion, strength and flexibility such that the sheeting can be handled, processed and applied according to the manufacturer's recommendations without appreciable stretching, tearing, cracking or other damage. Adhesive performance for retroreflective sheeting shall be in accordance with ASTM D 4956. The sheeting surface shall be in condition to be readily screen processed and compatible with transparent overlay films, plus recommended transparent and opaque screen process colors. The retroreflective sheeting manufacturer shall furnish information as to the type of solvent or solvents that may be used to clean the surface of the sheeting without detrimental loss of performance and durability. Retroreflective sheeting having a datum mark on the surface shall be oriented vertically. ASTM D 4956 Type IX, XI or AASHTO M 268 Type C or D retroreflective sheeting applied as legend and border for specific signing applications, without a datum mark on the surface of the sheeting, shall be evaluated for rotational sensitivity per AASHTO M 268, Section 3.3. Retroreflective sheeting products that do not meet the rotational sensitivity requirements of Section 3.3 shall follow guidelines detailed in AASHTO M 268 Section 3.3.1 and fabricated per AASHTO M 268 Section 3.3.2.

**1042.2.7.1** ASTM D 4956 Type I, Class 1 retroreflective sheeting shall be enclosed lens glass-bead or prismatic sheeting.

**1042.2.7.2** Background sheeting applied to flat sheet and extruded panel signs shall be in accordance with ASTM D 4956 Type IV, Class 1. All yellow, orange and red sheeted signs shall be fabricated with ASTM D 4956 Type IX, XI or AASHTO M 268 Type C or D fluorescent yellow, fluorescent orange and prismatic red sheeting respectively. Retroreflective sheeting shall be high intensity that is an unmetallized micro prismatic reflective material.

**1042.2.7.3** Retroreflective sheeting applied as legend and border shall be in accordance with ASTM D 4956, Type IX, XI or AASHTO Type C or D, Class 1. Retroreflective sheeting shall be an unmetallized cube corner microprismatic reflective material.

**1042.2.7.4 Screen Print and Overlay.** For screen printed transparent colored areas or transparent colored overlay films on white sheeting, the coefficient of retroreflection ( $R_A$ ) shall be no less than 70 percent of the original values for the corresponding color.

**1042.2.7.5** Reflective sheeting for temporary traffic control devices and delineators shall be in accordance with Sec 1063 and Sec 1065 respectively.

**1042.2.8 Outdoor Exposure.** Retroreflective sheeting, except for work zone signs, shall be submitted by the manufacturer to NTPEP for two years of 45-degree south-facing outdoor exposure. Retroreflective sheeting for work zone signs shall be submitted by the manufacturer to NTPEP for an exposure time of one year. Results shall be published by NTPEP and available for MoDOT review. For all NTPEP test decks, retroreflective sheeting shall have a coefficient of retroreflection at least 50 percent of the specified value for ASTM D 4956 Type I or 80 percent of the original reading for ASTM D 4956 Type IV, IX or XI.

**1042.2.9 Manufacturer and Brand Name Approval.** The manufacturer shall make available, upon request, NTPEP test results from all test decks, and certification to Construction and Materials, showing reflective material is in accordance with ASTM D 4956 specification. In addition, the manufacturer shall, upon request, submit samples representing the retroreflective sheeting tested by NTPEP, and with compatible inks. These samples shall be accompanied by a product data sheet, an MSDS, technical bulletins on sign fabrication and

# ATTACHMENT - D

any special fabrication instructions relative to the retroreflective sheeting submitted. Samples of retroreflective sheeting shall 10 x 10 inches and applied to an aluminum substrate.

**1042.2.9.1** Materials that fail to provide satisfactory field performance will be evaluated and may be disqualified from future use on fabricated signs for MoDOT. All corrective actions made by MoDOT will control.

**1042.2.10 Type of Characters.** Letters, numerals, arrows, symbols, borders and other features of the sign message shall be of the type, size and series shown on the plans or as specified by the engineer. Completed letters, numerals and other units shall be formed to provide a continuous stroke width with smooth edges, and shall yield a flat surface free of air bubbles, wrinkles or other blemishes as determined by the engineer. Units of the sign message shown on the plans shall meet the requirements for the specified type. Type L-1 and L-3 characters shall not be intermixed on a single sign face, unless otherwise shown on the plans or as approved by the engineer.

## **1042.2.10.1 Type L-1 Characters.**

**1042.2.10.1.1** The letters, numerals, arrows, symbols and borders shall be applied to the background of the sign by the direct or reverse screen process. Messages and borders of a color darker than the sign field shall be applied to the retroreflective sheeting by the direct process. Messages and borders of a color lighter than the sign field shall be produced by the reverse screen process. Inks used in the silkscreen process shall be of the type to produce the desired color and durability when applied on retroreflective sheeting. Silkscreen inks shall be used in accordance with the manufacturer's recommendations. The ink shall produce the desired color when applied on retroreflective sheeting background and shall dry to a good film without running, streaking or sagging. The screening shall be done in a manner that results in a uniform color and tone, with sharply defined edges of legend and border without blemishes on the sign field that will affect the intended use. Signs after screening shall be dried in accordance with the manufacturer's recommendations to provide a smooth hard finish. Any signs on which blisters appear during the drying process will be rejected.

**1042.2.10.1.2** Transparent overlay films may be used as a replacement for the reverse screen process, as recommended by the sheeting manufacturer.

**1042.2.10.2 Type L-3, Direct Applied Characters.** The letters, numerals, symbols, borders and other features of the sign message shall be cut from the color and type of sheeting shown on the plans, and applied to the sign field in accordance with the sheeting manufacturer's recommendations.

**1042.2.10.3 Allowable Variations.** The design height of rounded letters or numerals shall be 1/64 inch of height greater than normal height, both on top and bottom of letter or numeral, where rounded. The loop portion of letters such as f, g and y, shall conform to the dimensions shown on the plans with the allowable tolerance. The following variations in dimensions of letters and numerals, regardless of character type, will be acceptable with all measurements made to the nearest 1/8 inch.

Nominal Height, inches	Allowable Variation	
	Variation in Height, inches	Variation in Width, inches
4 thru 12	-1/8 to +3/8	-1/4 to +1/4
Over 12	-1/8 to +3/8	-3/8 to +3/8

**1042.3 Sign Fabrication.** A sign shall consist of aluminum flat sheets or extruded panels retroreflectORIZED on the face side with all letters, numerals, symbols, borders, corners and route shields mounted on the face, and shall include all necessary mounting devices shown on

# ATTACHMENT - D

the plans. Signs equal to or greater in width than six feet are considered structural (ST) and shall be fabricated on extruded panels. Signs less than six feet in width will be considered sheet (SH) signs and shall be fabricated with flat sheet. Any exceptions to these fabrication standards will be indicated on the plans.

**1042.3.1** All signs shall be of the highest quality with consistent daytime and nighttime color and retroreflectivity throughout the sign and produced as follows.

**1042.3.1.1** All aluminum substrate shall be given a chromate conversion coating in accordance with ASTM B 449, Class 2, and shall be prepared by one of the Treatment Sequence Options described in ASTM B 449, Appendix X2. The chemicals and solvents shall be applied in strict accordance with the manufacturer's recommendations. Sufficient laboratory facilities to test and control the concentration of the solutions used shall be maintained at the treating plant. A log of the concentration of treating solutions shall be maintained. Treated panels shall be handled in such a manner as to prevent contamination. Panels shall be stored in a dry, clean area free from dust, acid fumes or vapors. When aluminum is shipped to a secondary location for retroreflectorizing, adequate precautions shall be taken to ensure that the material arrives at the destination uncontaminated.

**1042.3.1.2** All materials used to fabricate a sign legend, including retroreflective and non-retroreflective sheeting, used for background, letters, numerals, arrows, symbols, borders and other features of the sign message shall be from a single manufacturer.

**1042.3.1.3** Retroreflective sheeting splices on structural signs shall be kept to a minimum. Rolled overlap splices in accordance with the sheeting manufacturer's recommendations may be used, with no more than one allowed per panel. Retroreflective sheeting shall be placed on the individual extruded panels in accordance with the manufacturer's recommendations. The sign panels may be clear coated or edge sealed after application of the retroreflective sheeting, if recommended by the sheeting manufacturer. If edge sealer is used, the sealer shall be applied to all splices and edges. The completed sign shall have good color matching of retroreflective sheeting and shall be free from air bubbles, wrinkles or other blemishes.

**1042.3.1.4** Retroreflective sheeting applied to standard flat sheet signs shall not have splices on signs where the smallest dimension is less than 4 feet. One vertical overlap splice approximately 1/4 inch wide will be allowed on standard flat sheet signs where the smallest dimension is greater than 4 feet. Any special flat sheet signs requiring splicing other than noted for the standard flat sheet signs shall be as approved by the engineer. The sign panels may be clear coated or edge sealed after application of the retroreflective sheeting if recommended by the sheeting manufacturer. If clear finish is used, the finish shall be applied after screening of messages and borders. If edge sealer is used, the sealer shall be applied to all splices and edges. The completed sign face shall be free from air bubbles, wrinkles or other blemishes.

**1042.3.2** Nuts on panel bolts used to connect extruded panels together to form a structural sign shall be torqued to 220 - 230 inch-pounds.

**1042.3.3** Signs will be accepted on certification from the manufacture assuring all fabrication and sheeting specifications are in compliance with all applicable requirements specified herein. Periodic shop inspections of sign fabrication will be made at the discretion of MoDOT, to include contractor furnished signs for MoDOT projects. Routine shop inspections will include inspection and sampling of materials, inspection of treatment and fabrication processes, and of any signs completed at time of inspection. Inspections on delivered signs for maintenance operations will be conducted for quality assurance purposes by the appropriate district inspectors. Signs may be rejected at the fabrication shop and/or upon delivery based on unsatisfactory workmanship and/or material applications or based on any aspect of the

## ATTACHMENT - D

product that is not in accordance with the specifications. The contractor will be charged with the transportation costs of sign inspectors for trips from Jefferson City, Missouri to which the inspectors must travel for signs provided to MoDOT projects. Transportation costs will be deducted by the Commission from monies due the contractor.

**1042.3.4** Signs shall be packaged and shipped according to the reflective sheeting manufacture's recommendations. Signs fabricated and shipped to MoDOT for maintenance operations shall be shipped in accordance with manufacture's recommendations and in a manner that meets the requirements of the engineer. All signs shall include decals indicating sign production date, lot number of reflective sheeting used in the production of sign and other information necessary for proper sign fabrication. Upon shipment of signs to MoDOT, certifications shall be submitted thereafter to Construction and Materials. Required paperwork shall include a certification statement indicating signs meet all applicable requirements herein to include aluminum standard and extruded panel, reflective sheeting (manufacturer, series and color), and hardware certifications. Material quantities, such as square foot of flat sheet, extruded panels, if produced, reflective sheeting and a shipping list of all signs shall be included in the certification packet.

# ATTACHMENT - E

## MISSOURI DEPARTMENT OF TRANSPORTATION APPROVED PRODUCTS LIST

### HIGHWAY SIGNING EQUIPMENT

#### V. GENERAL

This Approved Products List (APL) for highway signing equipment contains current pre-approved products for highway signing. This list is applicable to department purchases and construction contracts. The list includes products that have been approved for use based on satisfactory performance during a specified test period. Products listed have undergone sufficient field testing to be considered acceptable for use at any time. All field tests of new products or pending products should be arranged with Central Office Traffic.

The department frequently tests new products and equipment for highway signing. These new products may be installed on a construction project or used for normal department installations and maintenance. Vendors may also submit items, at no cost to the department, for the test period. Only a limited number of units will be accepted for test statewide until the product is added to the Approved Products List. A vendor wishing to initiate a test on a new product shall submit a Product Evaluation Request Form. Copies of this form can be obtained from our website at [www.modot.state.mo.us](http://www.modot.state.mo.us) or contact MoDOT Central Office Traffic. Minor model changes of previously approved products do not require a new evaluation period, although the vendor shall submit specification sheets and a sample of the product for the Department to inspect. Any modifications determined to potentially alter the performance of the product may require the product to undergo additional field testing and evaluation.

All product evaluations are coordinated through MoDOT Central Office Traffic. The vendor supplying the equipment shall provide equipment specifications and a certification that the equipment meets department specifications before the test is performed. The equipment is tested for the period specified by Central Office Traffic (typically one year). Products that are not performing satisfactorily will be left off of the list. Products that were previously approved that begin to perform unsatisfactorily will be removed or replaced with an approved product if the vendor cannot provide timely correction of the problem.

If a vendor is proposing a product that does not meet department specifications, an explanation of why the product meets or exceeds the current specifications must be provided by the vendor in writing to Central Office Traffic. If approved, the product may be tested for the specified period as described above. If the product is satisfactory, the Department will consider a revision to the applicable specifications. Products will not be added to the Approved Products List that does not meet department specifications.

Products on the APL shall continue to perform satisfactorily. In addition, the vendors shall support the products. Products not performing as required or not supported are subject to removal from the APL.

Grounds for removal of products include but are not limited to:

- Significant change in product specifications or design without notification to the department.
- Failure to correct or replace products that are defective in manufacturing or workmanship.
- Repeated patterns of malfunctions of a product not adequately corrected by the vendor.
- Unreasonable pricing of repair parts or repair work. Repair work not completed in a reasonable time frame.
- Excessive delivery times for new purchases or replacement parts.

Changes in standard specifications may also necessitate removal of specific products from the APL. If this occurs, there will be a grace period where the product will be retained on the list after the specifications are changed. However the product will eventually be removed from the list if it is not revised to meet specifications.

ATTACHMENT - E

MISSOURI DEPARTMENT OF TRANSPORTATION APPROVED PRODUCTS LIST

VI. HIGHWAY SIGNING EQUIPMENT

BREAKAWAY DEVICES

**MANUFACTURER DESCRIPTION, MODEL**

Ultimate Highway Products ..... Triangular Slip Base for 2.5" PSST, Slip-Mate  
Xcessories Squared ..... Kleen Break 425 for 2" PSST, XKB42520-G  
Xcessories Squared ..... Kleen Break Surface Mount 425 for 2" PSST,  
XKBSM42520-G

Xcessories Squared ..... Redi-Torque 280 for 2.5" PSST, SB8C-250A-G Xcessories  
Squared ..... Redi-Torque 280 Pre-Assembled Slip Base for 2.5" PSST, RT8UX-25C25-G

..... Redi-Torque Triangular Surface Mount Base, SMSB9-10-G

Xcessories Squared ..... Redi-Torque Bolt Kit, RTSB-MPHDW Northwest Pipe  
Company..... S-Q 8" Square Slipbase for 2.5" PSST, 31209 Designovations, Inc  
..... Snap n Safe S200 and S200S (2") Designovations, Inc  
..... Snap n Safe S250 and S250 S (2.5") Dent Breakaway Industries, Inc  
..... 3/4" Dent Bolt, #6882 Dent Breakaway Industries, Inc ..... 5/8" Dent  
Bolt, #6878 Dent Breakaway Industries, Inc ..... 1/2" Dent Bolt, #6874 Dent Breakaway  
Industries, Inc ..... 5/8" Ground Anchors (Galvanized) Dent Breakaway Industries, Inc  
..... 5/8" Modified Dent Bolt, #6220 Dent Breakaway Industries, Inc .....  
3/4" Modified Dent Bolt, #6882

FOUNDATIONS/ANCHORS

**MANUFACTURER DESCRIPTION, MODEL**

None ..... None

SIGN HARDWARE

**MANUFACTURER DESCRIPTION, MODEL**

Xcessories Squared ..... Aluminum Post Clamp for 2.5" Pipe, XAPC278RD  
Xcessories Squared ..... Aluminum Post Clamp for 3" Pipe, XAPC350RD Xcessories  
Squared ..... Aluminum Post Clamp for 4" Pipe, XAPC450RD Xcessories Squared  
..... Aluminum Bar for Post Clamps, XAB750 Xcessories Squared  
..... Aluminum Sign Backer Bar, ASB200P1 Xcessories Squared  
..... Extruded Panel Clamp for 2" PSST, EPPCS200SQ Xcessories Squared  
..... Extruded Panel Clamp for 2.5" PSST, EPPCS250SQ Xcessories Squared  
..... Extruded Panel Clamp for 2.5" Pipe, EPPCS250RD Xcessories Squared  
..... Extruded Panel Clamp for 3" Pipe, EPPCS300RD Xcessories Squared  
..... Extruded Panel Clamp for 4" Pipe, EPPCS400RD Xcessories Squared  
..... Extruded Panel Clamp for 4x4 Wood, EPPCS44W Xcessories Squared  
..... Extruded Panel Clamp for 4x6 Wood, EPPCS46W

ATTACHMENT - E

MISSOURI DEPARTMENT OF TRANSPORTATION APPROVED PRODUCTS LIST







Xcessories Squared ..... Extruded Panel Clamp for 6x6 Wood, EPPCS66W

SIGNS MANUFACTURER DESCRIPTION, MODEL

Tapco ..... Blinkersigns

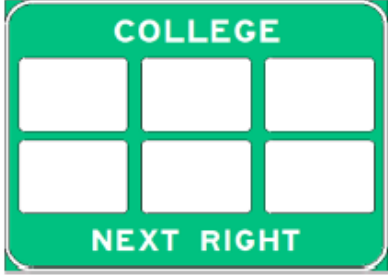
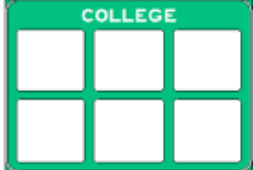
## ATTACHMENT - F

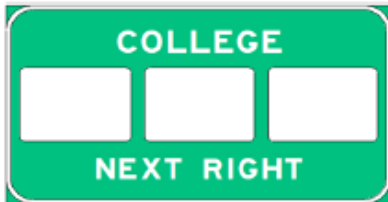
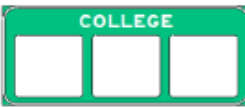
### EXAMPLE SIGNS FOR COLLEGES, WELCOME CENTER AFFILIATES, TRAFFIC GENERATOR AND CORRECTIONAL CENTER SIGNS

	MAINLINE SIGNS FOR FREEWAYS ONLY	RAMP SIGNS	TRAILBLAZER AND RAMP EMBLEM PANEL
<b>COLLEGE GENERATOR</b>	<p>VARIABLE X VARIABLE</p> 	<p>VARIABLE X VARIABLE</p>  <p>GENERATOR RAMP SIGN IS ALSO USED AS TRAILBLAZER</p>	<p>N / A</p>
<b>COLLEGE EMBLEM</b>	<p>14 FOOT X 11 FOOT</p> 	<p>9 FOOT X 7 FOOT</p> 	<p>1.5 FOOT X 1.5 FOOT</p>  <p>THIS PANEL IS USED AS A STANDALONE TRAILBLAZER, BUT IS ATTACHED TO THE RAMP SIGN AS AN EMBLEM PANEL</p>
<b>COLLEGE EMBLEM</b>	<p>14 FOOT X 8 FOOT</p> 	<p>9 FOOT X 4 FOOT</p> 	<p>THE SIZE OF THE MAINLINE AND RAMP SIGNS (NUMBER OF PANELS IT CAN DISPLAY) IS BASED ON THE NUMBER OF APPLICANTS WHICH MAY BE EXPECTED AT A GIVEN INTERCHANGE, JUST AS WITH LOGO SIGNS</p>
<b>WELCOME CENTER AFFILIATE</b>	<p>10 FOOT X 7 FOOT</p> 	<p>3 FOOT X 4 FOOT</p> 	
<b>GENERATOR - CORRECTIONAL CENTER</b>	<p><b>TRAFFIC GENERATORS AND STATE CORRECTIONAL CENTER SIGNS ARE WHITE LEGEND ON A GREEN BACKGROUND WITH NO PICTOGRAPHS. THE SIZE OF THE SIGN IS DETERMINED THE NAME OF THE FACILITY. APPEARANCE IS EQUAL TO COLLEGE GENERATOR WITHOUT THE PICTOGRAPH</b></p>		

Signs shown are for bidding purposes only, used to submit prices on RFP pricing page. Signs shown with dimensions are standard sizes; those shown as “variable x variable” vary in size based on site name. MoDOT’s Traffic and Highway Safety Division shall provide sign details for actual installations on a case by case basis.

# ATTACHMENT - G

## EXAMPLE SIGNS FOR STATE AND FEDERAL AGENCIES

	MAINLINE SIGNS FOR FREEWAYS ONLY	MAINLINE SIGNS FOR FREEWAYS AND EXPRESSWAYS	TRAILBLAZER SIGNS
DEPT. OF CONSERVATION	<b>13 FOOT X 9 FOOT</b> 	<b>11 FOOT X 5 FOOT</b> 	<b>6 FOOT X 2 FOOT</b> 
	<b>13 FOOT X 11 FOOT</b> 	<b>11 FOOT X 6 FOOT</b> 	<b>7 FOOT X 2 FOOT</b> 
DEPT. OF NATURAL RESOURCES	<b>13 FOOT X 12 FOOT</b> 	<b>11 FOOT X 7 FOOT</b> 	<b>3 FOOT X 4 FOOT</b> 
	<b>13 FOOT X 11 FOOT</b> 	<b>11 FOOT X 6 FOOT</b> 	<p><b>ALL STATE AND FEDERAL SITES UTILIZE THE SAME RAMP/TRAILBLAZER SIGN DESIGNS AS SHOWN ABOVE, INCLUDING THE PICTOGRAPH FOR THE AGENCY.</b></p> <p><b>ALL SIGNS ARE WHITE LEGEND ON A BROWN BACKGROUND.</b></p>
FEDERAL SITES	<p><b>FEDERAL SITE SIGN VARY IN SIZE BASED ON THE SITE NAME, THE SITE NAME AND ACTION MESSAGE ARE DISPLAYED ON THE PRIMARY SIGN (NO NAME PANEL) AND THERE IS NO PICTOGRAPH DISPLAYED</b></p>		

Signs shown are for bidding purposes only, used to submit price on RFP pricing page. Signs shown with dimensions are standard sizes, federal mainline sign sizes vary based on site name. All sites use the same design for ramp/trailblazer signs. MoDOT's Traffic and Highway Safety Division shall provide sign details for actual installations on a case by case basis.

# ATTACHMENT - H

## MATERIAL SPECIFICATIONS

Fabrication, installation and maintenance of signs in this program will be in conformance with the Missouri Standard Plans for Highway Construction and Missouri Standard Specifications for Highway Construction unless otherwise specified. The following is a summary, for the purposes of providing information for this request for proposal, of the common materials utilized for the signs in the supplemental signing program:

Extruded Panel Aluminum Substrate shall be used in the production of all Logo, Traffic Generator, College, State and Federal Agency, Welcome Center Affiliate or State Correctional Center mainline and ramp sign five feet in width or greater. State and Federal Agency trailblazer signing and TODS signs and TODS trailblazer signs are also fabricated with extruded panel aluminum substrate.

Flat Panel Aluminum Substrate, shall be 0.080 in thickness and used in the production of General Service panels, Logo trailblazers, Welcome Center Affiliate trailblazer or any trailblazer sign less than 5 feet in width.

Overlay Panels, if used, to modify, maintain or repair a sign face, the overlay shall be a minimum of 0.063 flat sheet aluminum. See figure Attachment #2 for installation details.

Sign Background Sheeting used to fabricate all signs shall be a minimum of ASTM Type IV High Intensity Prismatic sheeting.

Sign Legend on extruded panel signs shall be direct applied ASTM Type IX or XI, sign legend on flat sheet signs shall be screen printed or utilize transparent colored film overlays over a background sheeting of ASTM Type IV. Digital printing is not permitted unless specifically approved by MoDOT or if/when MoDOT adopts a specification for digital sign printing. If digital printing is approved, there shall be a permanent ID tag on the back of the sign indicating the manufacture, identifying it as a digitally printed sign and the date of manufacture. Signs fabricated in part or whole using digital shall be warranted for a minimum of 10 years. Signs which prematurely fail will be the responsibility of the successful offerer to replace with no additional cost to the applicant or the Commission.

Logo Panels shall be silk-screened or produced using translucent films. Digital printing is permitted for the fabrication of logo panels; however, there shall be a permanent ID tag on the back of the panel indicating the manufacturer, identifying it as a digitally printed sign and the date of manufacture. Logo panels fabricated in part or whole using digital shall be warranted for a minimum of 10 years. Signs which prematurely fail will be the responsibility of the successful offerer to replace with no additional cost to the applicant or the Commission.

Sign Supports shall all be a breakaway design meeting MoDOT Standards including U-channel, Perforated Square Steel Tube (PSST), Pipe or Structural Steel I-Beam. The Post Selection Guide in the MoDOT EPG shall be utilized to determine the acceptable post used for each type of sign. The post selection tool can be located at [903.3.1 Post-Mounted Sign Installation](http://epg.modot.org/index.php?title=903.3_Post-Mounted_Signing) [http://epg.modot.org/index.php?title=903.3\\_Post-Mounted\\_Signing](http://epg.modot.org/index.php?title=903.3_Post-Mounted_Signing)

## **ATTACHMENT - H**

Off State System: Mainline signing for any program can only be installed on Commission right of way. If the trailblazing of any sign program requires signing to be placed off of the Commission's right of way, the Program Manager shall obtain the necessary permissions and permits from the local jurisdiction with the authority over said roadway before installing any signs for the sign applicant. Signing on Commission right of way will not be allowed if the path to the site requires trailblazing off the state system and the Program Manager is not able to obtain the necessary permissions and/or permits from the local jurisdiction to complete the trailblazing.

# ATTACHMENT - I

## OVERLAY SPECIFICATIONS

When overlay panels are used to refurbish existing sign faces it shall be accomplished using a minimum 0.063 aluminum sheet fastened to the original sign using 3/16" aluminum rivets. The heads of the aluminum rivets shall be colored to match the sign background color. The rivet spacing shall be a maximum of 12 inches around the entire periphery of each individual panel, placed approximately 1 inch in from the edge of the panel. Rivets placed within the field of the panel shall be spaced a maximum of 24 inches from adjacent rivets. Figure below shows a typical overlay depicting the rivet spacing. Overlay panel may be wider than 4 feet; however, rivet spacing still applies.

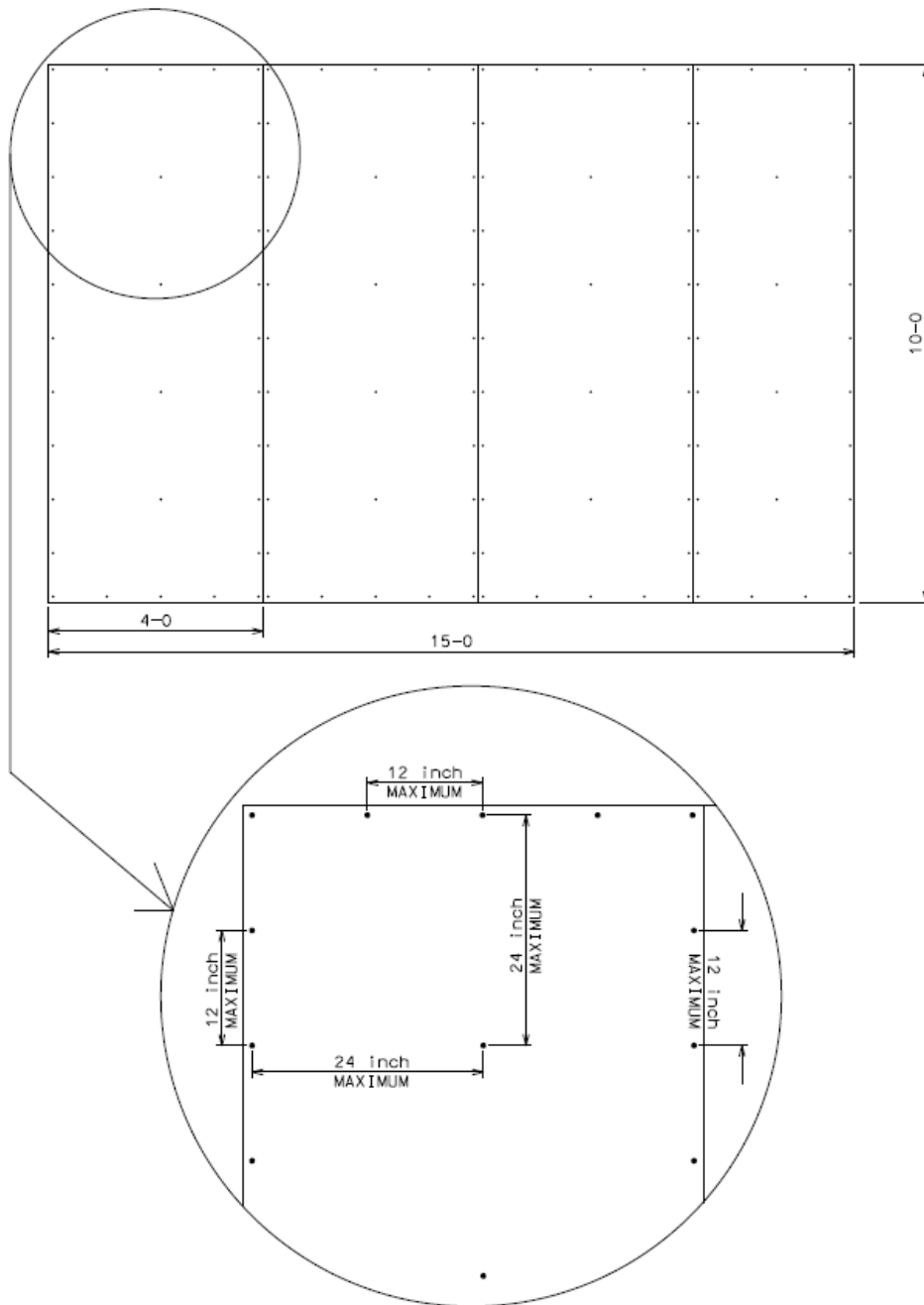

# ATTACHMENT - J

## FEDERAL MINIMUM SIGN RETROREFLECTIVITY STANDARDS

Sign Color	Sheeting Type (ASTM D4956-11a)				Additional Criteria
	Beaded Sheeting			Prismatic Sheeting	
	I	II	III	III, IV, VI, VIII, IX, XI	
White on green	W*; G ≥ 7	W*; G ≥ 15	W*; G ≥ 25	W ≥ 250; G ≥ 25	Overhead
	W*; G ≥ 7	W ≥ 120; G ≥ 15			Ground mounted
White on blue	W*; B ≥ 3	W*; B ≥ 5	W*; B ≥ 12	W ≥ 250; B ≥ 12	Overhead
	W*; B ≥ 3	W ≥ 120; B ≥ 7			Ground mounted
White on brown	W*; Br ≥ 1	W*; Br ≥ 5	W*; Br ≥ 10	W ≥ 350; Br ≥ 10	Overhead
	W*; Br ≥ 1	W ≥ 150; Br ≥ 5			Ground mounted
Black on yellow or black on orange	Y*; O*	Y ≥ 50; O ≥ 50			①
	Y*; O*	Y ≥ 75; O ≥ 75			②
White on red	W ≥ 35; R ≥ 7				③
Black on white	W ≥ 50				—
<p>The minimum MR levels shown in this table are in units of cd/lx/m<sup>2</sup> measured at an observation angle of 0.2 ° and an entrance angle of 4.0 °.</p> <p>① For text and fine symbol signs measuring at least 1,200 mm (48 inches) and for all sizes of bold symbol signs.</p> <p>② For text and fine symbol signs measuring less than 1,200 mm (48 inches).</p> <p>③ Minimum Sign Contrast Ratio ≥ 3:1 (white retroreflectivity + red retroreflectivity).</p> <p>* This sheeting type shall not be used for this color for this application.</p>					
<b>Bold Symbol Signs</b>					
<ul style="list-style-type: none"> <li>• W1-1, -2 – Turn and Curve</li> <li>• W1-3, -4 – Reverse Turn and Curve</li> <li>• W1-5 – Winding Road</li> <li>• W1-6, -7 – Large Arrow</li> <li>• W1-8 – Chevron</li> <li>• W1-10 – Intersection in Curve</li> <li>• W1-11 – Hairpin Curve</li> <li>• W1-15 – 270 Degree Loop</li> <li>• W2-1 – Cross Road</li> <li>• W2-2, -3 – Side Road</li> <li>• W2-4, -5 – T and Y Intersection</li> <li>• W2-6 – Circular Intersection</li> </ul>		<ul style="list-style-type: none"> <li>• W3-1 – Stop Ahead</li> <li>• W3-2 – Yield Ahead</li> <li>• W3-3 – Signal Ahead</li> <li>• W4-1 – Merge</li> <li>• W4-2 – Lane Ends</li> <li>• W4-3 – Added Lane</li> <li>• W4-5 – Entering Roadway Merge</li> <li>• W4-6 – Entering Roadway Added Lane</li> <li>• W6-1, -2 – Divided Highway Begins and Ends</li> <li>• W6-3 – Two-Way Traffic</li> <li>• W10-1, -2, -3, -4, -11, -12 – Highway-Railroad Advance Warning</li> </ul>		<ul style="list-style-type: none"> <li>• W11-2 – Pedestrian Crossing</li> <li>• W11-3 – Deer Crossing</li> <li>• W11-4 – Cattle Crossing</li> <li>• W11-5 – Farm Equipment</li> <li>• W11-6 – Snowmobile Crossing</li> <li>• W11-7 – Equestrian Crossing</li> <li>• W11-8 – Fire Station</li> <li>• W11-10 – Truck Crossing</li> <li>• W12-1 – Double Arrow</li> <li>• W16-5p, -6p, -7p – Pointing Arrow Plaques</li> <li>• W20-7a – Flagger</li> <li>• W21-1a – Worker</li> </ul>	
Fine Symbol Signs – Symbol signs not listed as Bold Symbol Signs.					
<b>Special Cases</b>					
<ul style="list-style-type: none"> <li>• W3-1 – Stop Ahead: red retroreflectivity ≥ 7</li> <li>• W3-2 – Yield Ahead: red retroreflectivity ≥ 7; white retroreflectivity ≥ 35</li> <li>• W3-3 – Signal Ahead: red retroreflectivity ≥ 7; green retroreflectivity ≥ 7</li> <li>• W3-5 – Speed Reduction: white retroreflectivity ≥ 50</li> <li>• For non-diamond-shaped signs such as W14-3 (No Passing Zone), W4-4p (Cross Traffic Does Not Stop), or W13-1, -2, -3, -5 (Speed Advisory Plaques), use largest sign dimension to determine proper minimum retroreflectivity level.</li> </ul>					

## ATTACHMENT - K

# GENERAL PROVISIONS AND SUPPLEMENTAL SPECIFICATIONS TO 2011 MISSOURI STANDARD SPECIFICATIONS FOR HIGHWAY CONSTRUCTION

### **SUPPLEMENTAL SIGNING**

**1.0 Description.** All installation, relocation and repair of Tourist Oriented Destination Signs (TODS), Specific Service Signing (Logos), Traffic Generator, College, State and Federal Agency, Welcome Center Affiliate and State Correctional Center shall be coordinated between the engineer, contractor and the designated Program Manager for MoDOT's Supplemental Signing Program.

**1.1** It shall be noted by the contractor that the Program Manager is responsible for the installation, relocation and repair of all TODS, Logo and Traffic Generator signs on Commission owned right of way. The contractor shall be solely responsible and liable for determining any impact to these signs due to contractor operations throughout the term of this contract. The contractor shall be responsible for notifying the Program Manager at the time of the preconstruction meeting when one of the supplemental signs is determined to be impacted and advise the Program Manager of the project details. The Program Manager will attend these meetings at their discretion.

The Program Manager shall be contacted during normal business hours Monday-Friday at the number provided by the Resident Engineer.

**1.2** The Program Manager will be responsible for any installation or relocation of these signs necessary for this contract. If the Program Manager has to perform work within the limits of the project, the Program Manager will conduct work so as not to interfere with or hinder the progress or completion of the work being performed by the contractor. Full cooperation of the contractors involved, in careful and complete coordination of their respective activities in the area, will be required.

**2.0 Basis of Payment.** No direct payment will be made to the contractor to recover the cost of equipment, labor, materials or time required to fulfill this provision.

## ATTACHMENT - L

### **ESTIMATED SIGNS IN ALL SUPPLEMENTAL SIGNING PROGRAMS**

The figures below represent the estimated number of participants and signs which will be involved in the signing programs pertaining to this RFP:

#### **TODS**

- 180 Customers (individual sites)
- 280 Individual Signs @ \$450 annual fee per sign
- Revenue FY 13 - \$124,200
- Revenue FY 14 - \$127,350
- Current Program only includes Tourist Oriented Sites

#### **Logos**

- 3386 Customers (individual sites)
- 5783 Logo Sign Panels (individual panels displayed on Logo signs)
  - 1,883 exit directions @ \$1,000 annual fee
  - 3,900 exit directions @ \$1,500 annual fee
- Revenue FY 13 - \$7,197,255
- Revenue FY 14 - \$7,416,806
- **Logo Program revenues increased in 2010. The implementation period for the increased revenues was 2 – 5 years, due to existing contract terms. As of July 1, 2015, the new fees will be fully implemented.**
- Participants per Category:
  - Gas 1,196
  - Food 3,252
  - Lodging 954
  - Camping 98
  - Attractions 251
  - Pharmacy 32

***FY 13 - 205 new contracts with 365 new mainline logo panel installations (logo panels displayed on the mainline sign)***

***FY 14 - 211 new contracts with 362 new mainline logo panel installations (logo panels displayed on the mainline sign)***

***Net program increase in mainline logo panel installations for these two years combined – 88***

## ATTACHMENT - L

### Traffic Generators

- FY 2013      479 Customers (individual sites)  
                    4 Renewals  
                    61 New Customers
  
- FY 2014      528 Customers (individual sites)  
                    14 Renewals  
                    49 New Customers
  
- \$0 Revenue Generated from any site in this category

### Signing Categories under the Traffic Generator Program:

- Private Tourist Oriented Sites
  - 32 Signed Sites
  - Approximately 260 signs ranging from 6' x 2' up to structural supplemental guide signs on freeways
  
- State and Federal Agency Sites – 355 Signed Sites
  - Approximately 1100 signs ranging from 6' x 2' up to structural supplemental guide signs on freeways
  
- Colleges
  - College Generator Signing - 43 Signed Sites
    - Approximately 86 Mainline Signs
    - Approximately 86 Ramp Signs
    - Approximately 85 Trailblazer Signs
  
  - College Emblem Signing - 68 Signed Sites
    - Approximately 136 Mainline Signs
    - Approximately 136 Ramp Signs
    - Approximately 171 Trailblazer Signs
  
- Welcome Center Affiliate – 9 Signed Sites
  - Approximately 81 signs with the majority of signs being mainline and ramp signs along with some smaller trailblazer signs
  
- State Correctional Centers – 21 Potential Signed Sites
  - Approximately 45 signs ranging from mainline and ramp signs along with smaller trailblazer signs