

BID FORMMISSOURI DEPARTMENT OF TRANSPORTATION
GENERAL SERVICESPO Box 270, Jefferson City, MO 65102(Mailing Address)
830 MoDOT Drive, Jefferson City, MO 65109 (Physical Address)

REQUEST NO.	2-170406RW1
DATE	March 28, 2017

SEALED BIDS, SUBJECT TO THE ATTACHED CONDITIONS WILL
BE RECEIVED AT THIS OFFICE UNTIL**2:00 PM, Central Time, April 6, 2017**AND THEN PUBLICLY OPENED AND READ FOR FURNISHING
THE FOLLOWING SUPPLIES OR SERVICES.**BID TO BE BASED F.O.B. MISSOURI DEPARTMENT OF
TRANSPORTATION**

Submit net bid as cash discount stipulations will not be considered

F.O.B. Destinations

Locations as Shown on Attachment

SIGN AND RETURN BEFORE TIME SET FOR OPENING

BUYER:	Robin Warren, Sr. General Services Specialist	BUYER TELEPHONE:	(573) 526-7929
BUYER EMAIL:	Robin.Warren@modot.mo.gov		

SUPPLIES OR SERVICESMoDOT is seeking bids from qualified bidders to provide **Traffic Signal Parts*******NOTE: It is the responsibility of the Bidder to access MoDOT's website in order to obtain any
and all addenda(s) issued during the course of this RFB process.****All questions regarding this RFB shall be submitted to the RFB Coordinator/Contact.****(SEE ATTACHED FOR CONDITIONS AND INSTRUCTIONS)***In compliance with the above Request For Bid, and subject to all conditions thereof, the undersigned bidder agrees to furnish and deliver
any or all the items on which prices were bid within the timeframe specified herein, after receipt of order.***Date:** _____**Telephone No.:** _____**Fax No.:** _____**Email Address:** _____**Firm Name:** _____**Address:** _____**By (Signature):** _____**Type/Print Name** _____**Title:** _____**Is your firm MBE certified?** Yes No**Is your firm WBE certified?** Yes No

1. INTRODUCTION AND GENERAL INFORMATION

1.1 Introduction:

- 1.1.1 This Request for Bid seeks bids from qualified bidders to provide Traffic Signal Parts throughout the State of Missouri with an effective contract period of Notice to Proceed through March 31, 2018, to the Missouri Highways and Transportation Commission (MHTC) and Missouri Department of Transportation (MoDOT).

Bids must be returned to the office of the General Services Procurement Division by no later than 2:00 p.m. Central Time, April 6, 2017.

RFB Coordinator:

**Robin Warren, Sr. General Services Specialist
Missouri Department of Transportation
General Services - Procurement**

PHONE: 573-526-7929

2. SCOPE OF WORK

2.1 General Requirements:

- 2.1.1 The Bidder shall provide traffic signal parts (hereinafter referred to as “parts”) on an as needed, if needed basis for the Missouri Highway and Transportation Commission (MHTC) and Missouri Department of Transportation (MoDOT), in accordance with the provisions and requirements stated herein.
- 2.1.2 The Bidder shall provide all parts to the sole satisfaction of MoDOT.
- 2.1.3 No estimated quantities are included as a part of this bid. Orders will be placed on an as needed, if needed basis by the districts.
- 2.1.4 MoDOT reserves the right to obtain “like or similar” products as specified herein from other manufacturers, exclusive of the contract, when use of such products is deemed in the best interest of the MoDOT.
- 2.1.5 Unless otherwise specified herein, the contractor shall furnish all material, labor, facilities, equipment, and supplies necessary to provide the parts required herein.

2.2 Specific Requirements:

- 2.2.1 All products shall conform to the latest revision of Section 1061, 1062 and 1092 of the Missouri Standard Specifications for Highway Construction and Section 902 of the Missouri Standard Plans for Highway Construction except 1092.1 through 1092.1.7. *See Appendix A.*
- 2.2.2 Unless otherwise specified herein, only items on the latest revision of the Missouri Department of Transportation Approved Products List for Traffic Signals and Highway Lighting Equipment will be accepted. *See Appendix B.*
- 2.2.3 If a category is not on the Approved Products List, specifications shall be submitted to compare with MoDOT specifications.
- 2.2.4 Only Programmable View LED Signal Modules on the following list will be accepted.

Approved Programmable View LED Signal Modules	Manufacturer Model
--	--------------------

Dialight	P463R33003 (Red Ball)
Dialight	P463Y33003 (Yellow Ball)
Dialight	P463G33003 (Green Ball)
GELcore	DR3-RCFB-01A (Red Ball)
GELcore	DR3-YCFB-01A (Yellow Ball)
GELcore	DR3-GCFB-01A (Green Ball)

2.3 Delivery Requirements:

- 2.3.1 The Bidder shall provide the parts to the Districts located throughout the State of Missouri. *See Attachment Map.*
- 2.3.2 All products must be received at the specified destination within 30-45 calendar days after the issue date of the purchase order.
- 2.3.3 Failure to deliver products in the specified delivery time will give MoDOT, at its discretion, the right to cancel the remainder of the contract without being considered in breach of contract and without any additional payment to the bidder.

2.4 Liquidated Damage Requirements:

In the event the successful Bidder fails to deliver within the time specified, the Department and the public will sustain damages because of such delay in delivery, the exact extent of which would be difficult to ascertain, and in order to liquidate such damage in advance it is agreed that the **sum of ten percent (10%) per day, per order**, for each assessable calendar day on which the delivery has not been completed, is reasonable and the best estimate which the parties can arrive at as liquidated damages, and it is therefore agreed that said amount will be withheld from payments due the Contractor or otherwise collected from the Contractor as liquidated damages. **Liquidated damages are not to exceed eighty percent (80%) of the value of the total order.**

2.5 Invoicing and Payment Requirements:

- 2.5.1 The Bidder shall submit an itemized invoice to the applicable requesting address upon the completion of delivery.
- 2.5.2 The Bidder shall be paid in accordance with the firm, fixed prices stated on the pricing page of this document, after completion of delivery and acceptance by MoDOT.
- 2.5.3 Other than the payment specified above, no other payments or reimbursements shall be made to the Bidder for any reason whatsoever.
- 2.5.4 MoDOT is exempt from paying Missouri Sales Tax, Missouri Use Tax and Federal Excise Tax.
- 2.5.5 Unless otherwise provided for in the solicitation documents, payment for all equipment, supplies, and/or services required herein shall be made in arrears. MoDOT shall not make any advance deposits.
- 2.5.6 MoDOT assumes no obligation for supplies shipped in excess of the quantity ordered. Any authorized quantity is subject to MoDOT's rejection and shall be returned at the Bidder's expense.
- 2.5.7 MoDOT reserves the right to purchase goods and services using the state-purchasing card.

2.6 Other Contractual Requirements:

- 2.6.1 **Contract Period** - The contract shall commence from the date of Notice of Award until March 31, 2017.
- 2.6.2 **Inspection Specifications** - MoDOT reserves the right to inspect the material at the point of manufacture, intermediate storage point, or at a destination which shall be at the discretion of MoDOT.

VENDOR INFORMATION & PREFERENCE CERTIFICATION FORM

Vendor Information

All bidders must furnish ALL applicable information requested below

Vendor Name/Mailing Address: Email Address:	Vendor Contact Information (including area codes): Phone #: Cellular #: Fax #:
Printed Name of Responsible Officer or Employee:	Signature:
For Corporations - State in which incorporated:	For Others - State of domicile:

If the address listed in the Vendor Name/Mailing Address block above is not located in the State of Missouri, list the address of Missouri offices or places of business:

*If additional space is required, please attach an additional sheet and identify it as **Addresses of Missouri Offices or Places of Business.***

M/WBE INFORMATION: List all certified Minority or Women Business Enterprises (**M/WBE**) utilized in the fulfillment of this bid. Include percentages for subcontractors and identify the M/WBE certifying agency:

<u>M/WBE Name</u>	<u>Percentage of Contract</u>	<u>M/WBE Certifying Agency</u>
_____	_____	_____
_____	_____	_____

*If additional space is required, please attach an additional sheet and identify it as **M/WBE Information***

Preference Certification

All bidders must furnish ALL applicable information requested below

GOODS/PRODUCTS MANUFACTURED OR PRODUCED IN USA: If any or all of the goods or products offered in the attached bid which the bidder proposes to supply to the MHTC are **not** manufactured or produced in the "United States", or imported in accordance with a qualifying treaty, law, agreement, or regulation, list below, by item or item number, the country other than the United States where each good or product is manufactured or produced.

Item (or item number)	Location Where Item is Manufactured or Produced

*If additional space is required, please attach an additional sheet and identify it as **Location Products are Manufactured or Produced.***

MISSOURI SERVICE-DISABLED VETERAN BUSINESS: Please complete the following if applicable. Additional information may be requested if preference is applicable. See below definitions for qualification criteria:

Service-Disabled Veteran is defined as any individual who is disabled as certified by the appropriate federal agency responsible for the administration of veterans' affairs.

Service-Disabled Veteran Business is defined as a business concern:

- a. Not less than fifty-one (51) percent of which is owned by one or more service-disabled veterans or, in the case of any publicly owned business, not less than fifty-one (51) percent of the stock of which is owned by one or more service-disabled veterans; and
- b. The management and daily business operations of which are controlled by one or more service-disabled veterans.

Veteran Information

Business Information

Service-Disabled Veteran's Name (Please Print)

Service-Disabled Veteran Business Name

Service-Disabled Veteran's Signature

Missouri Address of Service Disabled Veteran Business

COOPERATIVE PROCUREMENT

The Missouri Department of Transportation is interested in assisting Missouri governmental entities, etc. in purchasing equipment, various materials and supplies that meet the Missouri Department of Transportation specifications.

Each bidder is asked to indicate below whether they would be willing to offer **Traffic Signal Parts** listed in the attached "Request for Bid" for sale to these local political entities at the same bid price offered to this Department.

It is understood the Missouri Department of Transportation will not issue purchase orders, accept delivery nor make payment for these items ordered by any of these agencies. It is further understood the price is based on the **Traffic Signal Parts** meeting the Missouri Department of Transportation specifications. Any added options, deletions, or extra freight costs would be negotiated between the local agency and the successful vendor.

Indicate below whether your company is willing to offer such cooperative purchasing for Missouri counties, cities or other political entities.

YES _____

NO _____

If the price varies throughout the state on Missouri Department of Transportation bids because of different delivery destinations, please indicate the price f.o.b. your location that would be offered as described.

F.O.B. Location _____

Indicate the deadline date that orders will be accepted. _____

COMPANY NAME _____

ADDRESS _____

PHONE NUMBER _____

SIGNATURE _____

TITLE _____

DATE _____

(Each vendor should complete the appropriate sections of their form and submit with their bid.)

PRICING PAGES - RFB 2-170406RW1 SIGNAL PARTS - REBID

The bidder shall provide a firm, fixed price for providing the deliverables in accordance with the provisions and requirements specified herein. All costs associated with providing the required deliverables shall be included in the prices stated within.

TO BE CONSIDERED RESPONSIVE FOR A GROUP, PRICING MUST BE SUBMITTED ON ALL ITEMS WITHIN A GROUP.

*****DOUBLE CHECK YOUR INFORMATION ENTERED ON THIS FORM FOR ACCURACY*****

The manufacturer and catalog number listed for each item shall meet Missouri's Standard Specifications for Highway Construction and Approved Products List. Equipment shall be agreed to and approved prior to the contract award. All delivered equipment shall be the products listed below.

Item #	Unit	Group 7 - Wires and Cables	Unit Price	Manufacturer	Catalog Number
<i>Wire must meet International Municipal Signal Association (IMSA) specs and MoDOT Specs</i>					
082	spool	Loop Lead-In Wire, 2-Conductor - 14 gauge - 2500' spool			
083	spool	Loop Lead-In Wire, 2-Conductor - 14 gauge - 1000' spool			
084	spool	Loop Wire - 14 gauge XHHW in-duct - 2500' spool			
085	coil	1/4" Messenger Wire Cable Steel (Class A) - 250' Coil (Sec. 902.8 & Standard Drawing 902.70)			
086	coil	3/8" Messenger Wire Cable Steel (Class A) - 250' Coil			
087	spool	3-Conductor wire - 2500' wooden spool - 12 AWG			
088	spool	7-Conductor signal wire - 2500' wooden spool - 16 AWG (IMSA 19-1)			
089	spool	7-Conductor signal wire - 500' wooden spool - 16 AWG (IMSA 19-1)			
090	spool	7-Conductor signal wire - 2500' wooden spool - 16 AWG (IMSA 20-1)			
091	spool	7-Conductor signal wire - 500' wooden spool - 16 AWG (IMSA 20-1)			
Group 7 Total					

Item #	Unit	Group 10 - Pull Boxes	Unit Price	Manufacturer	Catalog Number
<i>Laminated Stickers will NOT be accepted. Pull Boxes must have a Cover Embossed with either "STATE SIGNALS" or "STATE LIGHTING".</i>					
<u>Straight:</u>					
101	ea	Preformed Pull Box - Class 1			
102	ea	Preformed Pull Box - Class 2			
103	ea	Preformed Pull Box - Class 3			
<u>Flared:</u>					
104	ea	Preformed Pull Box - Class 1			
105	ea	Preformed Pull Box - Class 2			
106	ea	Preformed Pull Box - Class 3			
107	ea	Preformed Pull Box - Class 5			
Group 10 Total					

MoDOT Type II Bracket Assembly

Pelco Parts make the Assembly

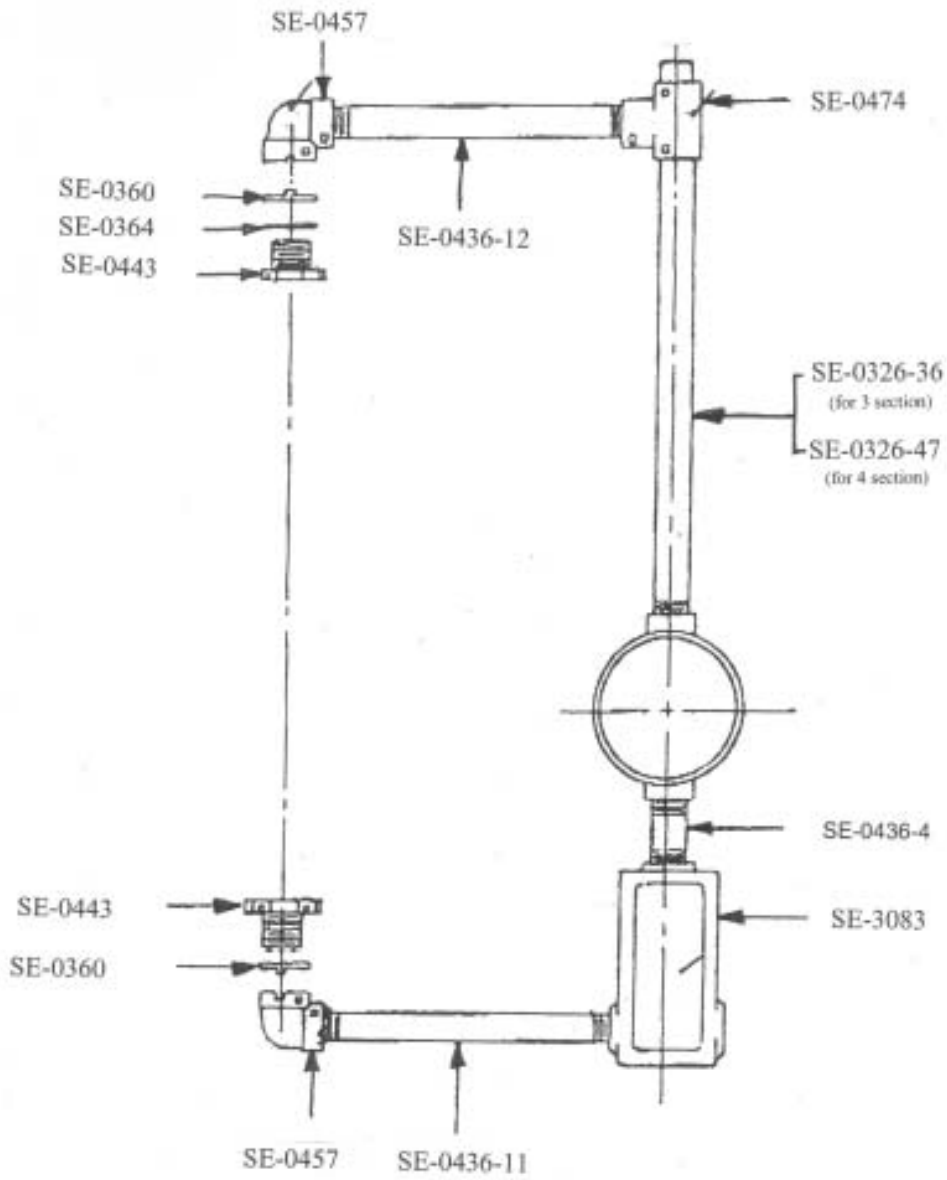

Missouri Highways and Transportation Commission
Standard Bid/Proposal Provisions, General Terms and Conditions and Special Terms and Conditions

STANDARD SOLICITATION PROVISIONS

- a. The solicitation for the procurement of the supplies referenced therein, to which these "Standard Bid Provisions, General Terms and Conditions and Special Terms and Conditions" are attached, is being issued under, and governed by, the provisions of Title 7 – Missouri Department of Transportation, Division 10 – Missouri Highways and Transportation Commission, Chapter 11 – Procurement of Supplies, of the Code of State Regulations. The Missouri Highways and Transportation Commission (**MHTC**), acting by and through its operating arm, the Missouri Department of Transportation (**MoDOT**), draws the Bidder's attention to said 7 CSR 10-11 for all the provisions governing solicitation and receipt of bids/quotes and the award of the contract pursuant to this solicitation.
- b. All bids/quotes must be signed with the firm name and by a responsible officer or employee. Obligations assumed by such signature must be fulfilled.

GENERAL TERMS AND CONDITIONS

Definitions

Capitalized terms as well as other terms used but not defined herein shall have the meaning assigned to them in section 7 CSR 10-11.010 Definition of Terms.

Nondiscrimination

- a. The Contractor shall comply with all state and federal statutes applicable to the Contractor relating to nondiscrimination, including, but not limited to, Chapter 213, RSMo; Title VI and Title VII of Civil Rights Act of 1964 as amended (42 U.S.C. Sections 2000d and 2000e, *et seq.*); and with any provision of the "Americans with Disabilities Act" (42 U.S.C. Section 12101, *et seq.*)
- b. **Sanctions for Noncompliance:** In the event of the Contractor's noncompliance with the nondiscrimination provisions of this contract, MHTC shall impose such contract sanctions as it or the Federal Highway Administration may determine to be appropriate, including, but not limited to:
 - i. withholding of payments to the Contractor under the contract until the Contractor complies, and/or,
 - ii. cancellation, termination or suspension of the contract, in whole or in part.

Contract/Purchase Order

- a. By submitting a bid/quote, the Bidder agrees to furnish any and all equipment, supplies and/or services specified in the solicitation documents, at the prices quoted, pursuant to all requirements and specifications contained therein.
- b. A binding contract shall consist of: (1) the solicitation documents, amendments thereto, and/or Best and Final Offer (BAFO) request(s) with any changes/additions, (2) the Contractor's bid response, and (3) the MHTC's acceptance of the bid by post-award contract or purchase order.
- c. A notice of award does not constitute an authorization for shipment of equipment or supplies or a directive to proceed with services. Before providing equipment, supplies and/or services, the Contractor must receive a properly authorized notice to proceed and/or purchase order.

Applicable Laws and Regulations

- a. The contract shall be construed according to the laws of the State of Missouri. The Contractor shall comply with all local, state, and federal laws and regulations related to the performance of the contract. The exclusive venue for any legal proceeding relating to or arising, out of the contract shall be in the Circuit Court of Cole County, Missouri.
- b. The Contractor must be registered and maintain good standing with the Secretary of State of the State of Missouri, Missouri Department of Revenue, and other regulatory agencies, as may be required by law or regulations. Prior to the issuance of a purchase order and/or notice to proceed, the Contractor may be required to submit to MHTC a copy of their current Authority Certificate from the Secretary of State of the State of Missouri and/or a copy of their Certificate of No Tax Due from the Missouri Department of Revenue.
- c. Prior to the issuance of a purchase order and/or notice to proceed, all **out-of-state** Contractors **providing services** within the state of Missouri must submit to MHTC a copy of their current Transient Employer Certificate from the Missouri Department of Revenue, in addition to a copy of their current Authority Certificate from the Secretary of State of the State of Missouri.

Executive Order:

The Contractor shall comply with all the provisions of Executive Order 07-13, issued by the Honorable Matt Blunt, Governor of Missouri, on the sixth (6th) day of March, 2007. This Executive Order, which promulgates the State of Missouri's position to not tolerate persons who contract with the state engaging in or supporting illegal activities of employing individuals who are not eligible to work in the United States, is incorporated herein by reference and made a part of this Agreement.

- 1) "By signing this Agreement, the Contractor hereby certifies that any employee of the Contractor assigned to perform services under the contract is eligible and authorized to work in the United States in compliance with federal law."
- 2) In the event the Contractor fails to comply with the provisions of the Executive Order 07-13, or in the event the Commission has reasonable cause to believe that the contractor has knowingly employed individuals who are not eligible to work in the United States in violation of federal law, the Commission reserves the right to impose such contract sanctions as it may determine to be appropriate, including but not limited to contract cancellation, termination or suspension in whole or in part or both.
- 3) The Contractor shall include the provisions of this paragraph in every subcontract. The Contractor shall take such action with respect to any subcontract as the Commission may direct as a means of enforcing such provisions, including sanctions for noncompliance.

Preferences

- a. In the evaluation of bids/quotes, preferences shall be applied in accordance with 7 CSR 10-11.020(7). Contractors should apply the same preferences in selecting subcontractors. The attached document entitled "**VENDOR INFORMATION AND PREFERENCE CERTIFICATION FORM**" must be completed and returned with the solicitation documents.
- b. Bidders are encouraged to obtain minority business enterprise (MBE) and women business enterprise (WBE) participation in this work through the use of subcontractors, suppliers, joint ventures, or other arrangements that afford meaningful participation for M/WBEs. Bidders are encouraged to obtain 10% MBE and 5% WBE participation.

Missouri Highways and Transportation Commission
Standard Bid/Proposal Provisions, General Terms and Conditions and Special Terms and Conditions

Cancellation of Contract

The MHTC may cancel the Contract at any time for a material breach of contractual obligations or for convenience by providing Contractor with written notice of cancellation. Should the MHTC exercise its right to cancel the contract for such reasons, cancellation will become effective upon the date specified in the notice of cancellation sent to the Contractor.

Bankruptcy or Insolvency

Upon filing for any bankruptcy or insolvency proceeding by or against the Contractor, whether voluntarily, or upon the appointment of a receiver, trustee, or assignee, for the benefit of creditors, the Commission reserves the right and sole discretion to either cancel the Agreement or affirm the Agreement and hold the Contractor responsible for damages.

Warranty

The Contractor expressly warrants that all equipment, supplies, and/or services provided shall: (1) conform to each and every specification, drawing, sample or other description which was furnished to or adopted by the MHTC, (2) be fit and sufficient for the purpose expressed in the solicitation documents, (3) be merchantable, (4) be of good materials and workmanship, and (5) be free from defect.

Status of Independent Contractor

The Contractor represents itself to be an independent Contractor offering such services to the general public and shall not represent itself or its employees to be an employee of the MHTC. Therefore, the Contractor shall assume all legal and financial responsibility for taxes, FICA, employee fringe benefits, workers' compensation, employee insurance, minimum wage requirements, overtime, etc., and agrees to indemnify, save and hold the MHTC, its officers, agents and employees harmless from and against any and all losses (including attorney fees) and damage of any kind related to such matters.

Non-Waiver

If one of the parties agrees to waive its right to enforce any term of this Contract, that party does not waive its right to enforce such term at any other time or to enforce any or all other terms of this Contract.

Indemnification

The Contractor shall defend, indemnify and hold harmless MHTC, including its members and department employees, from any claim or liability whether based on a claim for damages to real or personal property or to a person for any matter relating to or arising out of the Contractor's performance of its obligations under the contract awarded pursuant to this solicitation.

SPECIAL TERMS AND CONDITIONS

Delivery – Additional Requirements

a. The following days shall be construed as **official holidays** under the terms of the contract:

January 1	New Year's Day
Third Monday in January	Martin Luther King, Jr.'s Birthday
February 12	Lincoln's Birthday
Third Monday in February	Washington's Birthday
May 8	Truman's Birthday
Last Monday in May	Memorial Day
July 4	Independence Day
First Monday in September	Labor Day
Second Monday in October	Columbus Day
November 11	Veteran's Day
Fourth Thursday in November	Thanksgiving Day
December 25	Christmas Day

b. When any of the above **holidays falls** on a **Sunday**, the holiday will be observed on the following **Monday**; when any of the above **holidays falls** on a **Saturday**, the **holiday** will be observed on the immediately preceding **Friday**.

Missouri Department of Transportation District Map

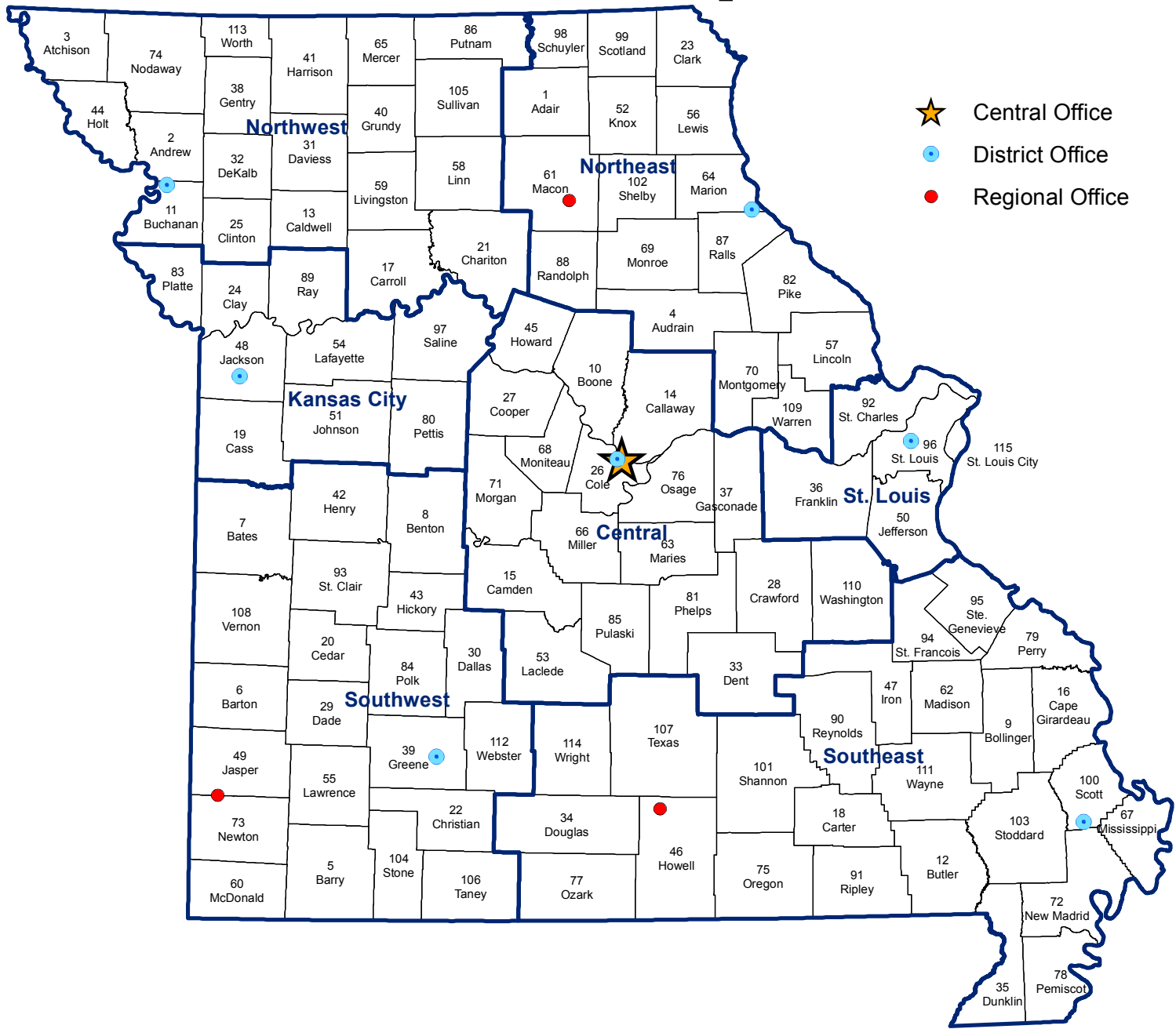

County	No. Dist.	County	No. Dist.	County	No. Dist.	County	No. Dist.	County	No. Dist.	County	No. Dist.						
Adair	1	NE	Chariton	21	NW	Harrison	41	NW	Macon	61	NE	Phelps	81	C	Shannon	101	SE
Andrew	2	NW	Christian	22	SW	Henry	42	SW	Madison	62	SE	Pike	82	NE	Shelby	102	NE
Atchison	3	NW	Clark	23	NE	Hickory	43	SW	Maries	63	C	Platte	83	KC	Stoddard	103	SE
Audrian	4	NE	Clay	24	KC	Holt	44	NW	Marion	64	NE	Polk	84	SW	Stone	104	SW
Barry	5	SW	Clinton	25	NW	Howard	45	C	Mercer	65	NW	Pulaski	85	C	Sullivan	105	NW
Barton	6	SW	Cole	26	C	Howell	46	SE	Miller	66	C	Putnam	86	NW	Taney	106	SW
Bates	7	SW	Cooper	27	C	Iron	47	SE	Mississippi	67	SE	Ralls	87	NE	Texas	107	SE
Benton	8	SW	Crawford	28	C	Jackson	48	KC	Moniteau	68	C	Randolph	88	NE	Vernon	108	SW
Bollinger	9	SE	Dade	29	SW	Jasper	49	SW	Monroe	69	NE	Ray	89	KC	Warren	109	NE
Boone	10	C	Dallas	30	SW	Jefferson	50	SL	Montgomery	70	NE	Reynolds	90	SE	Washington	110	C
Buchanan	11	NW	Davies	31	NW	Johnson	51	KC	Morgan	71	C	Ripley	91	SE	Wayne	111	SE
Butler	12	SE	Dekalb	32	NW	Knox	52	NE	New Madrid	72	SE	St. Charles	92	SL	Webster	112	SW
Caldwell	13	NW	Dent	33	C	Laclede	53	C	Newton	73	SW	St. Clair	93	SW	Worth	113	NW
Callaway	14	C	Douglas	34	SE	Lafayette	54	KC	Nodaway	74	NW	St. Francois	94	SE	Wright	114	SE
Camden	15	C	Dunklin	35	SE	Lawrence	55	SW	Oregon	75	SE	Ste. Genevieve	95	SE	St. Louis City	115	SL
Cape Girardeau	16	SE	Franklin	36	SL	Lewis	56	NE	Ozark	77	SE	St. Louis	96	SL			
Carroll	17	NW	Gasconade	37	C	Lincoln	57	NE	Pemiscot	78	SE	Saline	97	KC			
Carter	18	SE	Gentry	38	NW	Linn	58	NW			Schuyler	98	NE				
Cass	19	KC	Greene	39	SW	Livingston	59	NW			Scotland	99	NE				
Cedar	20	SW	Grundy	40	NW	McDonald	60	SW			Scott	100	SE				

