

BID FORMMISSOURI DEPARTMENT OF TRANSPORTATION
GENERAL SERVICESPO Box 270, Jefferson City, MO 65102(Mailing Address)
830 MoDOT Drive, Jefferson City, MO 65109 (Physical Address)

REQUEST NO.	2-150630RW
DATE	June 19, 2015

SEALED BIDS, SUBJECT TO THE ATTACHED CONDITIONS WILL
BE RECEIVED AT THIS OFFICE UNTIL**2:00 PM, Central Time, June 30, 2015**AND THEN PUBLICLY OPENED AND READ FOR FURNISHING
THE FOLLOWING SUPPLIES OR SERVICES.**BID TO BE BASED F.O.B. MISSOURI DEPARTMENT OF
TRANSPORTATION**

Submit net bid as cash discount stipulations will not be considered

F.O.B. Destinations

Locations as Shown on Attachment

SIGN AND RETURN BEFORE TIME SET FOR OPENING

BUYER:	Robin Warren, Sr. General Services Specialist	BUYER TELEPHONE:	(573) 526-7929
BUYER EMAIL:	Robin.Warren@modot.mo.gov		

SUPPLIES OR SERVICESMoDOT is seeking bids from qualified bidders whom can provide **Various Plow Blades*******NOTE: It is the responsibility of the Bidder to access MoDOT's website in order to obtain any
and all addenda(s) issued during the course of this RFB process.****All questions regarding this RFB shall be submitted to the RFB Coordinator/Contact.****(SEE ATTACHED FOR CONDITIONS AND INSTRUCTIONS)***In compliance with the above Request For Bid, and subject to all conditions thereof, the undersigned bidder agrees to furnish and deliver
any or all the items on which prices were bid within the timeframe specified herein, after receipt of order.***Date:** _____**Telephone No.:** _____**Fax No.:** _____**Email Address:** _____**Firm Name:** _____**Address:** _____**By (Signature):** _____**Type/Print Name** _____**Title:** _____**Is your firm MBE certified?** Yes No**Is your firm WBE certified?** Yes No

1. INTRODUCTION AND GENERAL INFORMATION

1.1 Introduction:

- 1.1.1 This Request for Bid seeks bids from qualified organizations to provide Various Plow Blades throughout the State of Missouri with an effective contract period of Notice to Proceed through April 30, 2016, to the Missouri Highways and Transportation Commission (MHTC) and Missouri Department of Transportation (MoDOT).

Bids must be returned to the office of the General Services Procurement Division by no later than 2:00 p.m. Central Time, June 30, 2015.

RFB Coordinator:

**Robin Warren, Sr. General Services Specialist
Missouri Department of Transportation
General Services - Procurement**

PHONE: 573-526-7929

2. SCOPE OF WORK

2.1 General Requirements:

- 2.1.1 The Bidder shall provide various plow blades (hereinafter referred to as “blades”) on an as needed, if needed basis for the Missouri Highway and Transportation Commission (MHTC) and Missouri Department of Transportation (MoDOT), in accordance with the provisions and requirements stated herein.
- 2.1.2 The Bidder shall provide all blades to the sole satisfaction of MoDOT.
- 2.1.3 The Bidder shall furnish all parts, and/or supplies necessary for the blades to be complete and ready to use.
- 2.1.4 MoDOT estimates, but does not guarantee, the purchase of the estimated quantities stated herein.
- 2.1.5 MoDOT anticipates multiple contracts being awarded within the various categories of the blades, with the selection of contractor to be used to be based upon price, availability, and product meeting specifications. In the event the lowest bidder for a particular blade is unable to provide the required blade(s) due to unavailability or product not meeting specifications, MoDOT shall contact the next lowest bidder. If additional bidders exist for that particular blade(s), MoDOT shall continue to use the same criteria until the needs of MoDOT are met. The Bidder shall agree and understand that the selection shall be made by MoDOT and that such selection shall be final and without recourse.
- 2.1.6 MoDOT reserves the right to obtain “like or similar” products as specified herein from other manufacturers, exclusive of the contract, when use of such products is deemed in the best interest of the MoDOT.
- 2.1.7 Unless otherwise specified herein, the contractor shall furnish all material, labor, facilities, equipment, and supplies necessary to provide the deliverables required herein.

2.2 Specific Requirements:

- 2.2.1 The contractor shall provide MoDOT with the following blade types, meeting the MGS Specification indicated and any other provisions outlined in this request for bid.
 - a. Carbide Tipped Snow Plow Blades (MGS-91-01Q)
 - b. Dual Carbide Tipped Underbody Snow Plow Blades (MGS-01-02D)
 - c. Maintainer and Loader Blades (MGS-91-03J)

2.3 Delivery Requirements:

- 2.3.1 The contractor shall provide the blades as specified herein to the following MoDOT Districts located throughout the State of Missouri. *See Attachment B – Estimated Quantities per District*
- 2.3.2 Orders will be placed by districts for delivery to one or multiple locations within a district.
- 2.3.3 No blades shall be delivered in a box truck.
- 2.3.4 *All blade orders placed by July 15, 2015 shall be delivered to the various MoDOT locations by no later than October 1, 2015.*
- 2.3.5 Delivery locations shall be contacted at least 24 hours prior to delivery, or as indicated at the time of order.
- 2.3.6 The contractor shall deliver all blades F.O.B. destination.

2.4 Liquidated Damage Requirements:

2.4.1 In the event the successful Contractor fails to deliver the material within the time specified, the Department and the public will sustain damages because of such delay in delivery, the exact extent of which would be difficult to ascertain, and in order to liquidate such damage in advance it is agreed that the **sum of \$100 per day, per order, not to exceed 20% of order amount** for each assessable calendar day on which the delivery has not been completed, is reasonable and the best estimate which the parties can arrive at as liquidated damages, and it is therefore agreed that said amount will be withheld from payments due the Contractor or otherwise collected from the Contractor as liquidated damages.

Saturdays, Sundays, holidays and days whereas the Department has suspended work shall not be assessable days.

2.4.2 The contractor shall agree and understand that providing the blades in accordance with the requirements stated herein is considered critical to the efficient operations of MoDOT. However, since the amount of actual damages would be difficult to establish in the event the contractor fails to comply with the contractual requirements, the contractor shall agree and understand that the amount identified below shall be reasonable and fair under the circumstances.

- a. In the event the contractor fails to provide blades in accordance with the contractual requirements specified herein, the contractor shall agree and understand that MoDOT shall solely determine which of the following percentages of deduction shall be assessed against the contractor for the contractor's noncompliance, and such shall be final and without recourse.

The following definitions shall pertain to the cobalt content of the Tungsten Carbide Inserts within the carbide tipped and dual carbide tipped snow plow blades.

Deduction Rate Table

Slight	15 %
Moderate	25 %
Severe	50 %

Slight – Cobalt content greater than 10.0% and less than 10.5% **OR** greater than 12.5% and less than 13.0%.

Moderate - Cobalt content greater than 9.5% and less than 10.0% **OR** greater than 13.0% and less than 13.5%.

Severe - Cobalt content less than 9.5% **OR** greater than 13.5%.

- b. In addition to the above, accepted deliveries for carbide blades not meeting specifications for additional requirements on MGS-91-01Q or MGS-01-02D shall be invoiced and paid at a twenty percent (20%) reduction of awarded bid price.
- c. The contractor shall agree and understand that such liquidated damages shall either be deducted from the total amount due the contractor or paid by the contractor as a direct payment to the MoDOT, at the sole discretion of the MoDOT.
- d. The contractor shall agree and understand that the liquidated damages described herein shall not be construed as a penalty.
- e. The contractor shall agree and understand that all assessments of liquidated damages shall be in addition to, not in lieu of, the rights of the MoDOT to pursue other appropriate remedies.
- f. The contractor shall understand and agree that all assessments of liquidated damages shall be within the discretion of each District as a separate entity, and shall be in addition to, not in lieu of, the rights of the MoDOT to pursue other appropriate remedies. The contractor shall understand and agree that each District's decision shall be individual, final, and without recourse.

- g. The contractor shall agree and understand that if a product(s) is rejected due to not meeting specifications, all cost associated with returning the product to the contractor shall be paid by the contractor, at no additional cost to MoDOT.

2.5 Invoicing and Payment Requirements:

- 2.5.1 The contractor shall submit an itemized invoice to the applicable requesting MoDOT address.
- 2.5.2 Each invoice should be itemized in accordance with items listed on the purchase order and/or contract. The statewide financial management system has been designed to capture certain receipt and payment information. Therefore, each invoice submitted must reference the purchase order number and must be itemized in accordance with items listed on the purchase order. Failure to comply with this requirement may delay processing of invoices for payment.
- 2.5.3 The contractor shall be paid in accordance with the firm, fixed prices stated on the pricing page(s) of this document after completion of deliverables specified herein and acceptance by MoDOT.
- 2.5.4 Other than the payment specified above, no other payments or reimbursements shall be made to the contractor for any reason whatsoever.
- 2.5.5 MoDOT is exempt from paying Missouri Sales Tax, Missouri Use Tax and Federal Excise Tax.
- 2.5.6 Unless otherwise provided for in the solicitation documents, payment for all equipment, supplies, and/or services required herein shall be made in arrears. The Missouri Highways and Transportation Commission (MHTC) shall not make any advance deposits.
- 2.5.7 The MHTC assumes no obligation for equipment, supplies, and/or services shipped or provided in excess of the quantity ordered. Any authorized quantity is subject to the MHTC's rejection and shall be returned at the contractor's expense.
- 2.5.8 The MHTC reserves the right to purchase goods and services using the state-purchasing card.

2.6 Other Contractual Requirements:

- 2.6.1 **Contract Period** - The contract shall commence from the notice to proceed until April 30, 2016.
- 2.6.2 **Inspection Specifications** - MoDOT reserves the right to inspect the material at the point of manufacture, intermediate storage point, or at a destination which shall be at the discretion of MoDOT.

VENDOR INFORMATION & PREFERENCE CERTIFICATION FORM

Vendor Information

All bidders must furnish ALL applicable information requested below

Vendor Name/Mailing Address: Email Address:	Vendor Contact Information (including area codes): Phone #: Cellular #: Fax #:
Printed Name of Responsible Officer or Employee:	Signature:
For Corporations - State in which incorporated:	For Others - State of domicile:

If the address listed in the Vendor Name/Mailing Address block above is not located in the State of Missouri, list the address of Missouri offices or places of business:

*If additional space is required, please attach an additional sheet and identify it as **Addresses of Missouri Offices or Places of Business.***

M/WBE INFORMATION: List all certified Minority or Women Business Enterprises (**M/WBE**) utilized in the fulfillment of this bid. Include percentages for subcontractors and identify the M/WBE certifying agency:

<u>M/WBE Name</u>	<u>Percentage of Contract</u>	<u>M/WBE Certifying Agency</u>
_____	_____	_____
_____	_____	_____

*If additional space is required, please attach an additional sheet and identify it as **M/WBE Information***

Preference Certification

All bidders must furnish ALL applicable information requested below

GOODS/PRODUCTS MANUFACTURED OR PRODUCED IN USA: If any or all of the goods or products offered in the attached bid which the bidder proposes to supply to the MHTC are **not** manufactured or produced in the "United States", or imported in accordance with a qualifying treaty, law, agreement, or regulation, list below, by item or item number, the country other than the United States where each good or product is manufactured or produced.

Item (or item number)	Location Where Item is Manufactured or Produced

*If additional space is required, please attach an additional sheet and identify it as **Location Products are Manufactured or Produced.***

MISSOURI SERVICE-DISABLED VETERAN BUSINESS: Please complete the following if applicable. Additional information may be requested if preference is applicable. See below definitions for qualification criteria:

Service-Disabled Veteran is defined as any individual who is disabled as certified by the appropriate federal agency responsible for the administration of veterans' affairs.

Service-Disabled Veteran Business is defined as a business concern:

- a. Not less than fifty-one (51) percent of which is owned by one or more service-disabled veterans or, in the case of any publicly owned business, not less than fifty-one (51) percent of the stock of which is owned by one or more service-disabled veterans; and
- b. The management and daily business operations of which are controlled by one or more service-disabled veterans.

Veteran Information

Business Information

Service-Disabled Veteran's Name (Please Print)

Service-Disabled Veteran Business Name

Service-Disabled Veteran's Signature

Missouri Address of Service Disabled Veteran Business

COOPERATIVE PROCUREMENT

The Missouri Department of Transportation is interested in assisting Missouri governmental entities, etc. in purchasing equipment, various materials and supplies that meet the Missouri Department of Transportation specifications.

Each bidder is asked to indicate below whether they would be willing to offer **Various Plow Blades** listed in the attached "Request for Bid" for sale to these local political entities at the same bid price offered to this Department.

It is understood the Missouri Department of Transportation will not issue purchase orders, accept delivery nor make payment for these items ordered by any of these agencies. It is further understood the price is based on the **Various Plow Blades** meeting the Missouri Department of Transportation specifications. Any added options, deletions, or extra freight costs would be negotiated between the local agency and the successful vendor.

Indicate below whether your company is willing to offer such cooperative purchasing for Missouri counties, cities or other political entities.

YES _____

NO _____

If the price varies throughout the state on Missouri Department of Transportation bids because of different delivery destinations, please indicate the price f.o.b. your location that would be offered as described.

F.O.B. Location _____

Indicate the deadline date that orders will be accepted. _____

COMPANY NAME _____

ADDRESS _____

PHONE NUMBER _____

SIGNATURE _____

TITLE _____

DATE _____

(Each vendor should complete the appropriate sections of their form and submit with their bid.)

ATTACHMENT A - PRICING PAGE

The bidder shall provide firm, fixed prices in the table below for providing the deliverables in accordance with the provisions and requirements of this RFB. All costs associated with providing the deliverables shall be included in the prices stated below. **Blades shall be delivered to the address indicated on the notice to proceed or purchase order.**

Commodity Code	Description	Estimated Quantity	Price Per Blade	Delivery Time ARO***	Inspection Point
-----------------------	--------------------	---------------------------	------------------------	-----------------------------	-------------------------

Category 1

7600613442	BLADE, CARBIDE TIPPED 3/4" X 5" X 3'	180			
7600613452	BLADE, CARBIDE TIPPED 3/4" X 5" X 4'	658			
7600613462	BLADE, CARBIDE TIPPED 3/4" X 5" X 5'	76			

Category 2

7600610147	BLADE, DUAL CARBIDE TIPPED UNDERBODY 7/8" X 5" X 3'	46			
7600610159	BLADE, DUAL CARBIDE TIPPED UNDERBODY 7/8" X 5" X 4'	34			
7600610163	BLADE, DUAL CARBIDE TIPPED UNDERBODY 7/8" X 5" X 5'	315			

Category 3

7600610106	BLADE, MAINTAINER LENGTH 7' WIDTH 8" THICKNESS 1/2"	16			
------------	---	-----------	--	--	--

You are not required to submit pricing for all categories, but you are required to submit pricing for each item within any category for which you bid.

*****Delivery time indicated in this blank is for calendar days after receipt of order (ARO) for orders placed after 7/15 (See Section 2.3.4 under Delivery Requirements)**

Company _____

Signature _____

ATTACHMENT B - ESTIMATED QUANTITIES PER DISTRICT

Commodity Code	Description	NW	CD	SE	NE	Total Estimated Qty
7600613442	BLADE, CARBIDE TIPPED 3/4" X 5" X 3'	64	81		35	180
7600613452	BLADE, CARBIDE TIPPED 3/4" X 5" X 4'	181	244		233	658
7600613462	BLADE, CARBIDE TIPPED 3/4" X 5" X 5'		76			76
7600610147	BLADE, DUAL CARBIDE TIPPED UNDERBODY 7/8" X 5" X 3'		24		22	46
7600610159	BLADE, DUAL CARBIDE TIPPED UNDERBODY 7/8" X 5" X 4'		2		32	34
7600610163	BLADE, DUAL CARBIDE TIPPED UNDERBODY 7/8" X 5" X 5'		133	102	80	315
7600610106	BLADE, MAINTAINER LENGTH 6' WIDTH 8" THICKNESS 1/2"	16		48		64



DUAL CARBIDE TIPPED UNDERBODY SNOW PLOW BLADES MGS-01-02D

1.0 DESCRIPTION. This specification covers dual tipped carbide underbody snowplow blades.

2.0 MATERIALS.

2.1 Steel. The blades shall be fabricated from flat hot rolled carbon steel meeting the requirements of either ASTM 576-90b or ASTM 575-89 with the range of Grades SAE 1020 or equal.

2.2 Tungsten Carbide Inserts. The inserts shall be a high shock WC Grade of tungsten carbide.

2.2.1 The inserts shall meet Virgin Tungsten Carbide quality specifications and shall meet the following requirements.

2.2.1.1 Face Insert Characteristics:

Specification	Requirement
Cobalt Content, percent	19.0 – 21.0
Density, g/cm ³ (ASTM B 311)	13.25 - 13.65
Hardness (ASTM B 294, Rockwell A Scale)	83.5 - 85.0
Transverse Rupture Strength, psi, min.	330,000

2.2.1.2 Center Insert Characteristics:

Specification	Requirement
Cobalt Content, percent	10.5 - 12.5
Density, g/cm ³ (ASTM B 311)	14.1 - 14.6
Hardness (ASTM B 294, Rockwell A Scale)	87.5 - 89.0
Transverse Rupture Strength, psi, min.	350,000

2.2.2 The insert shall be rectangular and trapezoid design with the following dimensions for each:

2.2.2.1 Face Insert Dimensions:

Specification	Requirement
Height, inch	0.745 ± 0.005
Width, inch	0.310 ± 0.010
Length, inch, nominal	2

2.2.2.2 Center Insert Dimensions:

Specification	Requirement
Height, inch, long side	0.635 ± 0.005
Width, inch	0.365 ± 0.010
Length, inch, nominal	1
Bottom Angle	25 degrees with a nose radius of 1/16-inch minimum.

2.3 Finished Blades.

2.3.1 Insert Placement. The groove for the carbide inserts shall be milled on the blade edge. The tungsten carbide inserts shall be positioned in the milled area with approximately 0.010-inch space between the inserts the entire length of each cutting edge section. Each of the inserts shall be one-inch nominal length for the center inserts and two-inch nominal length for the face inserts. It may be necessary for some of the inserts to be different than the nominal lengths to make up for the spacing between the inserts. The number of one-inch inserts shall be no less than one or more than three from the number required for one insert per inch of blade length. The number of two-inch inserts shall be no less than one or more than two from the number required for one insert per two inches of blade length.

2.3.2 Brazing. The inserts shall be brazed on all contact surfaces consistent with sound brazing practice with no evidence of voids or use of shims. Brazing shall be of such strength and quality as required to prevent movement or loss of the inserts during use.

2.3.3 Physical Requirements. All blades shall be straight and free from flaws and injurious defects, and shall have workmanlike finish.

2.3.3.1 The finished blade sections shall be free of warpage and longitudinal deviation shall not exceed 1/8 inch in a four-foot or five-foot long blade section or 3/32 inch in a three-foot long blade section. The edge that rests upon the pavement shall be straight and true. The longitudinal warp and the alignment of this edge shall be measured by extending a straight edge from one end of the blade to the other and measuring from the straight edge to the blade at the mid-point of length.

2.3.3.2 The difference between the highest and lowest tip point shall not exceed 1/32 inch on any given blade assembly.

2.3.3.3 Punching shall be 11/16 inch square holes with 1 5/32 inch diameter countersink 3/8 inch deep to receive either 5/8 inch or 3/4 inch diameter plow bolts as required. Location of holes shall be in accordance with AASHTO standards for "heavy-duty" punching. Details, location, and spacing of the holes shall be as shown on the attached drawing for a standard state highway three-, four- or five-foot blade.

2.3.3.4 Moldboards are punched with holes 1/8 inch larger than the blade bolts. Accordingly, blade punching will be of such accuracy, both for the spacing between holes and for the spacing between the end hole and the end of the blade, that the blades will fit the moldboards, thus making the blade sections interchangeable.

2.3.4 The paint used to coat the blades shall be dry prior to shipment and shall not smear or track during handling.

3.0 CERTIFICATION AND ACCEPTANCE.

3.1 Prior to approval and use of any material delivered, the manufacturer shall submit to the State Project Operations Engineer, P.O. Box 270, Jefferson City, Missouri 65102, a certification in triplicate certifying the grade of steel used in fabricating the blade and certifying that the blades supplied conform to all requirements and specifications.

3.1.1 The "Certification Statement" form shown in Section 5.0 is to be used when certifying. The certification shall include or have attached specific results of test performed on the tungsten

carbide inserts for cobalt content, density, hardness and transverse rupture strength and showing the standard test designation of the test specified for each of these properties. The certification shall show the purchase order number, destination, quantity of material represented at each destination and shipping date.

3.2 Acceptance of the blades and carbide tip inserts shall be based on the manufacturer's certification and upon the results of such tests as may be performed on samples of the material. When samples are taken, one complete blade of each length shall be taken to represent the shipment. A shipment will be considered as all blades represented on one certification and shipped on one date, regardless of various destinations. The carbide tip inserts shall be sampled from the blades selected for testing.

3.2.1 If a blade fails to meet any of the specified requirements, two additional blades will be selected for retest from the same quantity represented by that certification. Both of these retest samples must meet all requirements or the entire quantity will be rejected.

3.2.2 If the carbide tip inserts fail to meet any of the specified requirements, two additional samples will be selected either from the original blade sampled or from other blades contained in the same quantity represented by that certification. Both of these retest samples must meet all requirements or the entire quantity will be rejected.

3.2.3 If the blades are rejected, no payment will be made and the cost of blades destroyed during sampling and testing shall be borne by the supplier.

4.0 TEST METHOD MODOT T21 DETERMINATION OF COBALT IN TUNGSTEN CARBIDE INSERTS.

4.1 Scope.

4.1.1 This method describes a procedure for determining the percent of Cobalt in Tungsten Carbide Inserts used in Snowplow Blades, using a Inductively Coupled Plasma Optical Emission Spectrophotometer (ICP-OES). The specification may be accessed at

http://epg.modot.mo.gov/index.php?title=106.7.21_TM-21%2C_Determination_of_Cobalt_in_Tungsten_Carbide_Inserts

5.0 CERTIFICATION STATEMENT.

CERTIFICATION STATEMENT
DUAL CARBIDE TIPPED UNDERBODY SNOWPLOW BLADES

State Project Operations Engineer
P. O. Box 270
Jefferson City, MO 65102

Dear Sir:

We hereby certify that the dual carbide tipped underbody snowplow blades described below comply with all requirements of Specification **MGS-01-02D** and in accordance with bid request No. _____.

The following blades manufactured by _____ are covered by this certification.

Purchase Order No.	Destination	Quantity & Size	Shipping Date

Following are results of tests performed on these blades:

Grade of Steel in the Blade: _____

Cobalt Content in Carbide Tip: _____ Test Method: _____

Density of Carbide Tip: _____ Test Method: _____

Hardness of Carbide Tip: _____ Test Method: _____

Transverse Rupture Strength: _____ Test Method: _____

Certified By: _____

Title: _____

Date: _____

Results of tests may be shown on attachments rather than on this form, if preferred.

This form is to be completed, signed, and submitted in triplicate for each shipment, at the same time as blades are shipped. A shipment is defined as all blades represented on one certification and shipped on one date, regardless of various destinations.

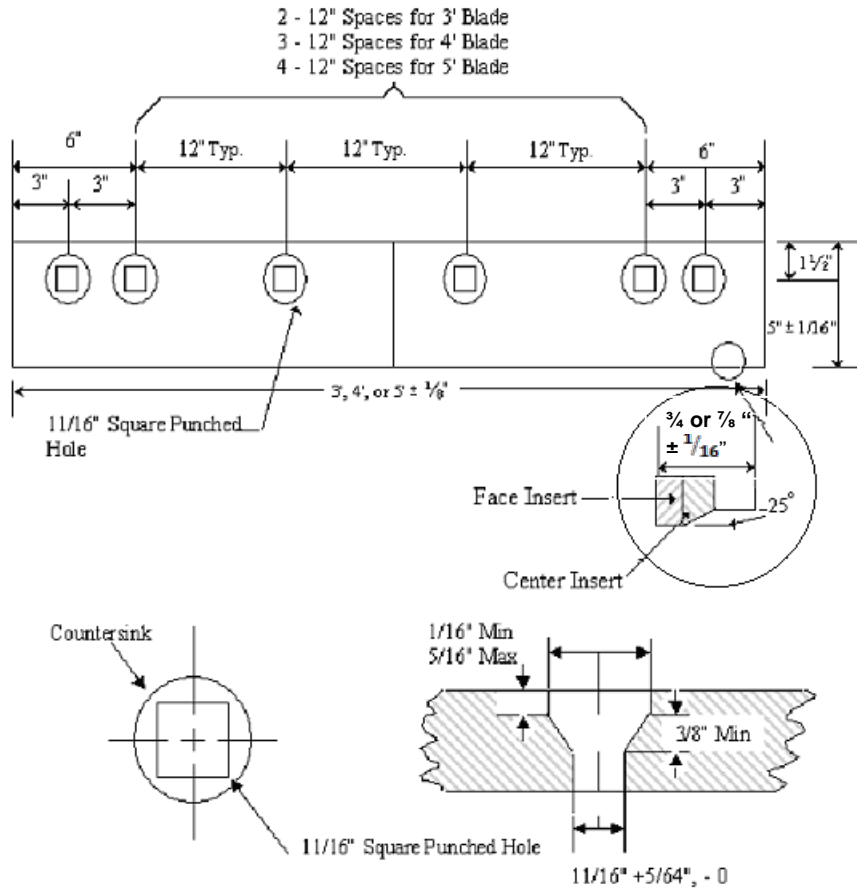

NOTE: This drawing not to scale.

Plan of Dual Carbide Tipped Snowplow Blades



MAINTAINER AND LOADER BLADES MGS-91-03J

1.0 Description. This specification covers maintainer and loader blades fabricated from plate steel meeting the requirements and dimensions specified herein.

2.0 Materials.

2.1 Chemical Composition. When sampled and tested in accordance with the designated methods set forth in ASTM E 30 and/or TM 57, the following chemical requirements shall apply.

<u>Maintainer Blades</u>	<u>Min.</u>	<u>Max.</u>
Carbon, Percent, (Direct Combustion Method)	0.75	0.98
Manganese, Percent, (Bismuthate Method)	0.60	0.90
Phosphorus, Percent, (Alkalimetric Method)	----	0.04
Sulfur, Percent, (Evolution Method)	----	0.05
Silicon, Percent, (Sulfuric Acid Method)	----	0.30

<u>Loader Blades</u>	<u>Min.</u>	<u>Max.</u>
Carbon, Percent, (Direct Combustion Method)	0.55	0.98
Manganese, Percent, (Bismuthate Method)	0.60	1.30
Phosphorus, Percent, (Alkalimetric Method)	----	0.04
Sulfur, Percent, (Evolution Method)	----	0.05
Silicon, Percent, (Sulfuric Acid Method)	----	0.30

2.2 Physical Requirements.

2.2.1 Brinell Hardness, (ASTM E10).

Maintainer Blades: 250 minimum, 325 maximum.

Loader Blades: 220 minimum, 325 maximum.

2.2.2 Punching. The blades are to be punched in accordance with the detailed drawings which are attached and made a part of these specifications.

2.2.2.1 Moldboards are punched with holes 1/8 inch larger than the blade bolts. Accordingly, blade punching will be of such accuracy, both for the spacing between the holes and for the spacing between the end hole and the end of the blade, that the blades will fit the moldboards, thus making the blade sections interchangeable.

2.2.3 Dimensions.

2.2.3.1 Maintainer Blades. Maintainer blades are to be curved, top edge beveled to fit the moldboard, lower and both ends square. The following dimensions and tolerances shall apply.

Width	8 inches ± 1/8 inch
Length	as requisitioned with tolerance of ± 1/8 inch
Thickness	5/8 inch ± 1/16 inch

2.2.3.2 Loader Blades. Loader blades shall be straight, bottom edge and both ends square, top edge beveled to fit the moldboard. The following dimensions and tolerances shall apply.

Thickness:	1 inch \pm 1/16 inch
Width:	10 inches \pm 1/8 inch
Length:	As requisitioned with tolerance of \pm 1/8 inch
Thickness of Tip of Cutting Edge:	1/8 inch \pm 1/16 inch

2.2.3.3 The blades are to have hole spacings and dimensions in accordance with the standard cutting edge punchings as shown on the attached drawings.

2.2.3.1 The finished blades shall not be twisted and shall be free from flaws and injurious defects and shall have good workmanlike finish. Longitudinal warp is allowed but shall not deviate more than 1/8 inch per foot of blade length and shall be uniformly distributed over the length of the blade. For a 6 foot long blade a 3/4 inch warp would be allowed. The cutting edge that rests upon the pavement shall be straight and true. The longitudinal warp and the alignment of the cutting edge shall be measured by extending a straight edge from one end of the blade to the other measuring from the straight edge to the blade at the mid-point of length.

2.2.4 Weight. Maintainer blades shall have a weight per linear foot of 12.5 pounds with a 5 percent minus tolerance. Eight inch by 3/4 inch loader blades shall have a weight per linear foot of 18.5 pounds with a 5 percent minus tolerance. Ten inch by 1 inch loader blades shall have a weight per linear foot of 31.0 pounds with a 5 percent minus tolerance. To determine the weight per linear foot not less than ten or more than twenty blades of identical sizes may be selected at random from a shipment and weighed on accurate scales.

2.2.5 Any paint used to coat the blades shall be dry prior to shipment and shall not smear or track during handling.

3.0 Certification and Acceptance.

3.1 Prior to approval and use of any material delivered, the manufacturer shall submit to the State Materials Engineer, P. O. Box 270, Jefferson City, Missouri 65102, a certification in triplicate certifying the blades supplied conform to all requirements of these specifications.

3.1.1 The "Certification Statement" form shown in Section 4.0 is to be used when certifying. The certification shall include or have attached specific results of tests performed on the blades for chemical composition, hardness and weight per linear foot. The certification shall show the purchase order number, destination, quantity of material represented at each destination and shipping date.

3.2 Acceptance of the blades shall be based on the manufacturer's certification and upon results of such tests as may be performed on samples of the material. When samples are taken, one complete blade of each length shall be taken to represent the shipment. A shipment will be considered as all blades represented on one certification and shipped on one date, regardless of various destinations. If a blade fails to meet any of the specified requirements, two additional blades will be selected for retest from the same quantity represented by that certification. Both of these retest samples must meet

all requirements or the entire quantity will be rejected.

3.3 If the blades are rejected, no payment will be made and the cost of blades destroyed during sampling and testing shall be borne by the supplier.

4.0 Certification Statement.

**CERTIFICATION STATEMENT
MAINTAINER AND LOADER BLADES**

State Materials Engineer
P. O. Box 270
Jefferson City, Missouri 65102

Dear Sir:

We hereby certify that the maintainer and loader blades described below comply with all requirements of Specification [MGS-91-03J](#) and in accordance with Bid Request No. _____.

The following blades manufactured by _____ are covered by this certification.

Purchase Order No.	Destination	Quantity & Size	Shipping Date

Following are results of test performed on these blades:

<u>Chemical Composition</u> Percent C _____ Percent Mn _____ Percent P _____ Percent S _____ Percent Si _____	Brinell Hardness _____ Weight Per Linear Foot _____ CertifiedBy: _____ Title: _____ Date: _____
--	---

Results of tests may be shown on attachments rather than on this form, if preferred.

This form is to be completed, signed, and submitted in triplicate for each shipment, at the same time as blades are shipped. A shipment is defined as all blades represented on one certification and shipped on one date, regardless of various destinations.

MISSOURI DEPARTMENT OF TRANSPORTATION
STANDARD CUTTING EDGE PUNCHINGS FOR MAINTAINER BLADES

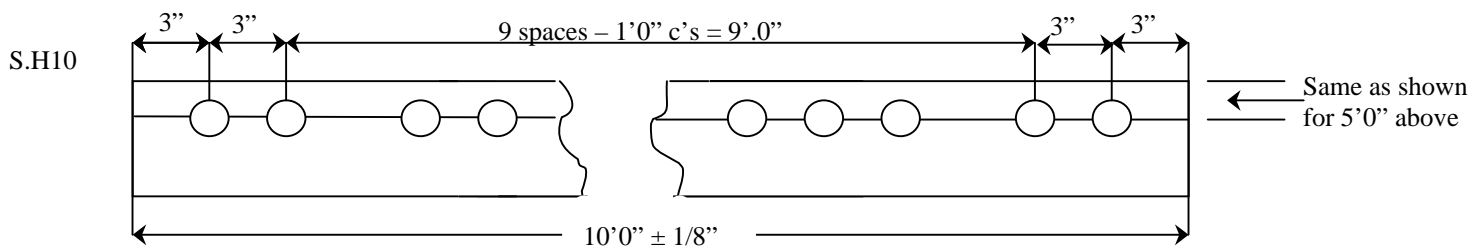
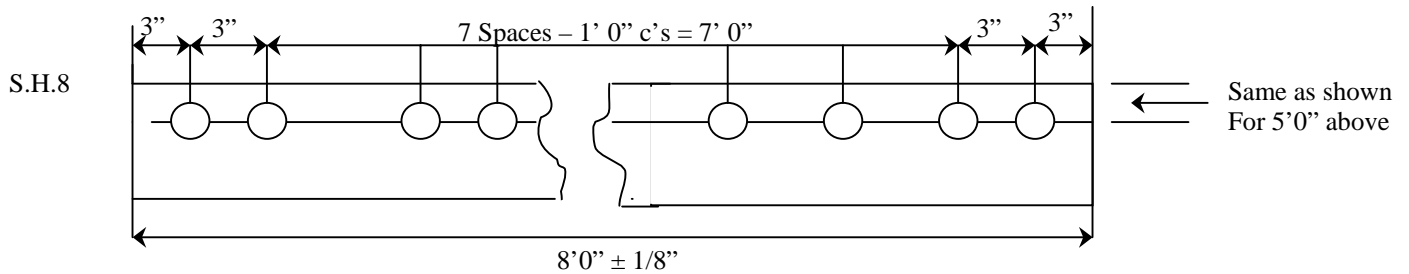
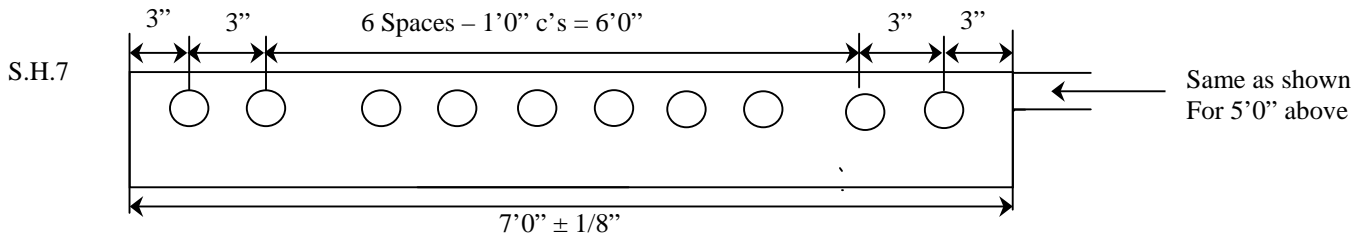
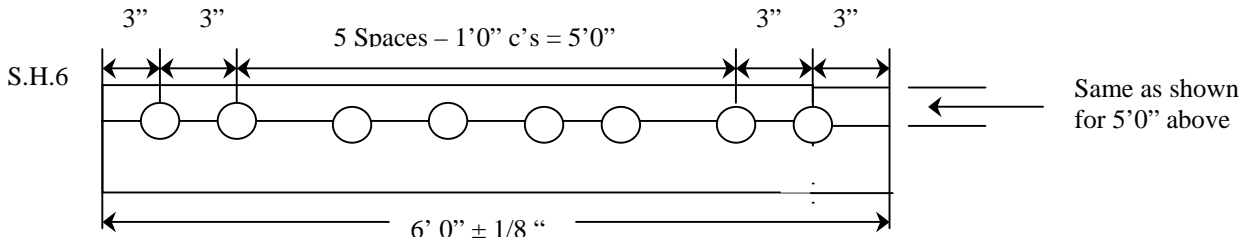
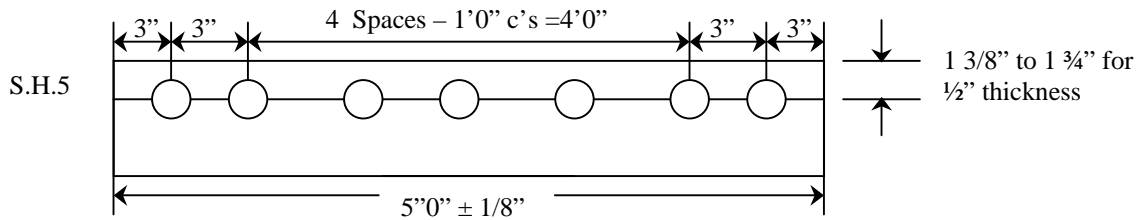

Blades of odd 66" lengths to be punched similar to above except that the 12" spaces nearest the ends of blade becomes 9" spaces. i.e., 5'6" blade hole spacing is 3"-3"9"-12"-12"-9"-3"-3". For blades over 10'0" length use two shorter lengths.

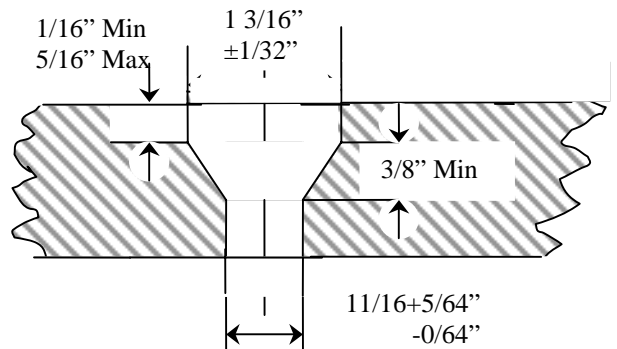
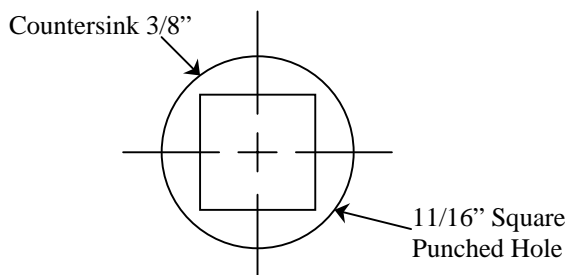

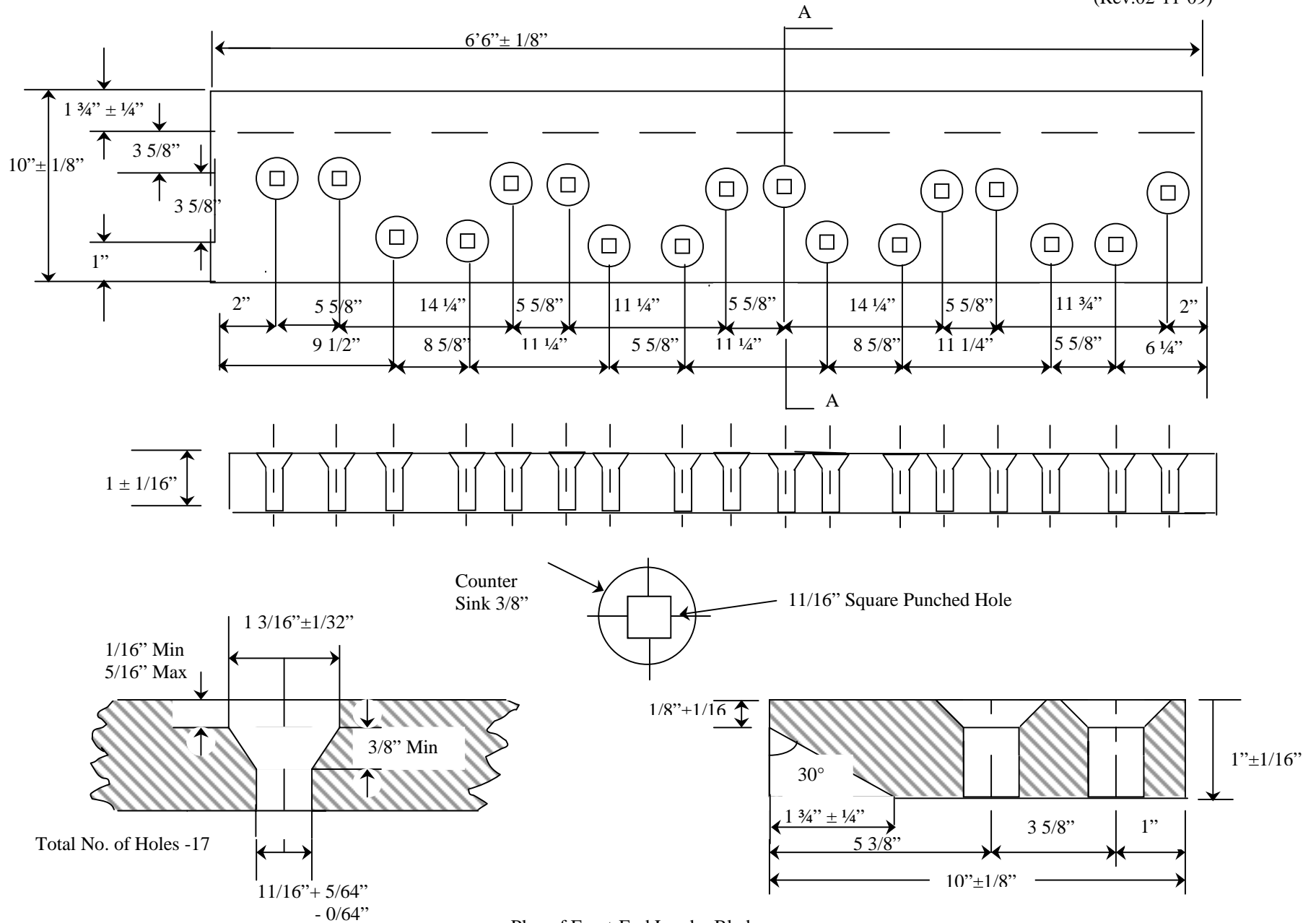

Plan of Front-End Loader Blade

NOTE: This drawing not to scale. Follow Dimensions

NOTE: For Use of $5/8'' \times 2''$ or $3''$ Square Deep
 Countersunk No.3 Head Plug Bolt

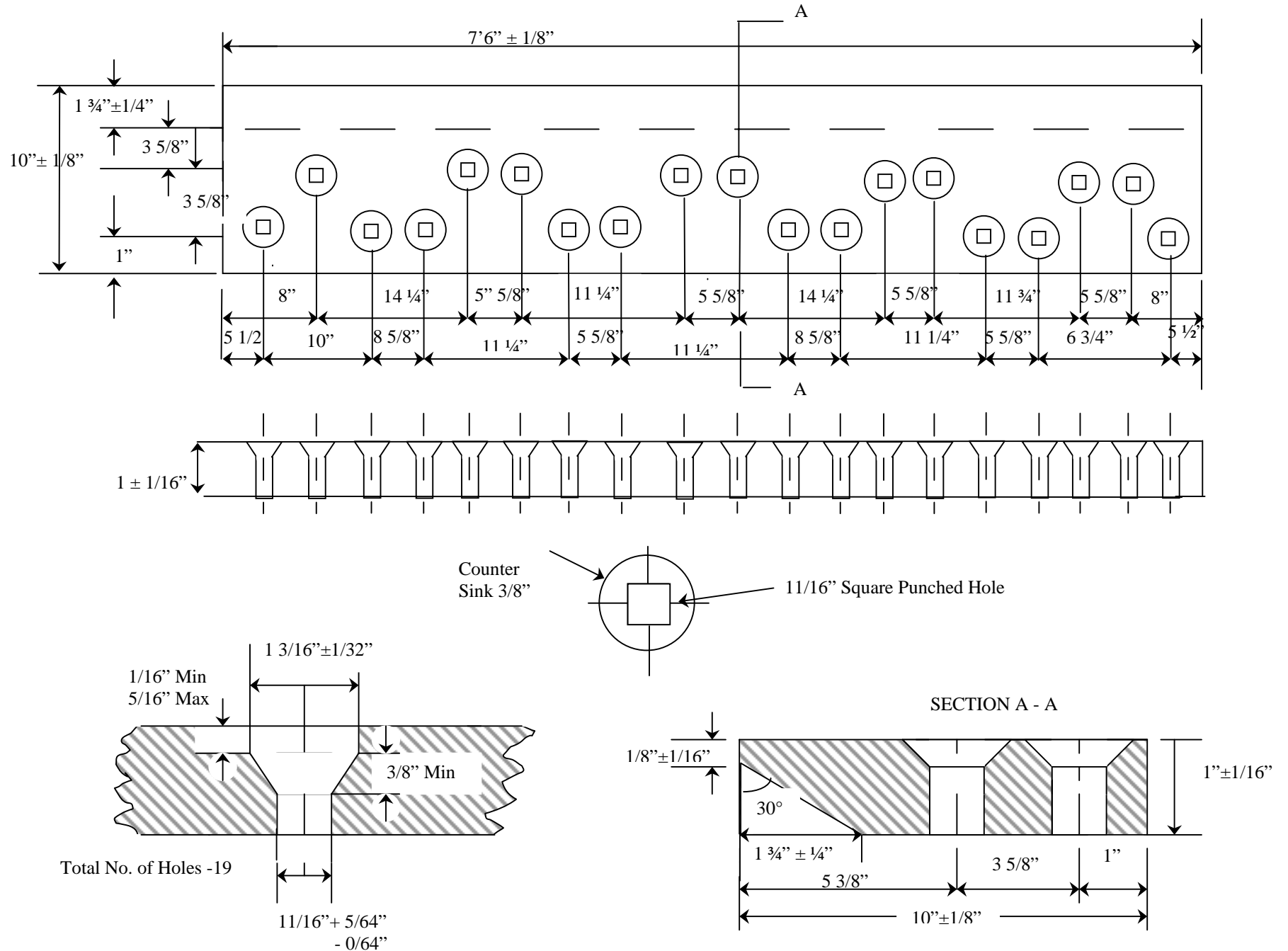

NOTE: This drawing not to scale. Follow Dimensions

Plan of Front-End Loader Blade

NOTE: For Use of $5/8'' \times 2''$ or $3''$ Square Deep Countersunk No.3 Head Plow Bolt

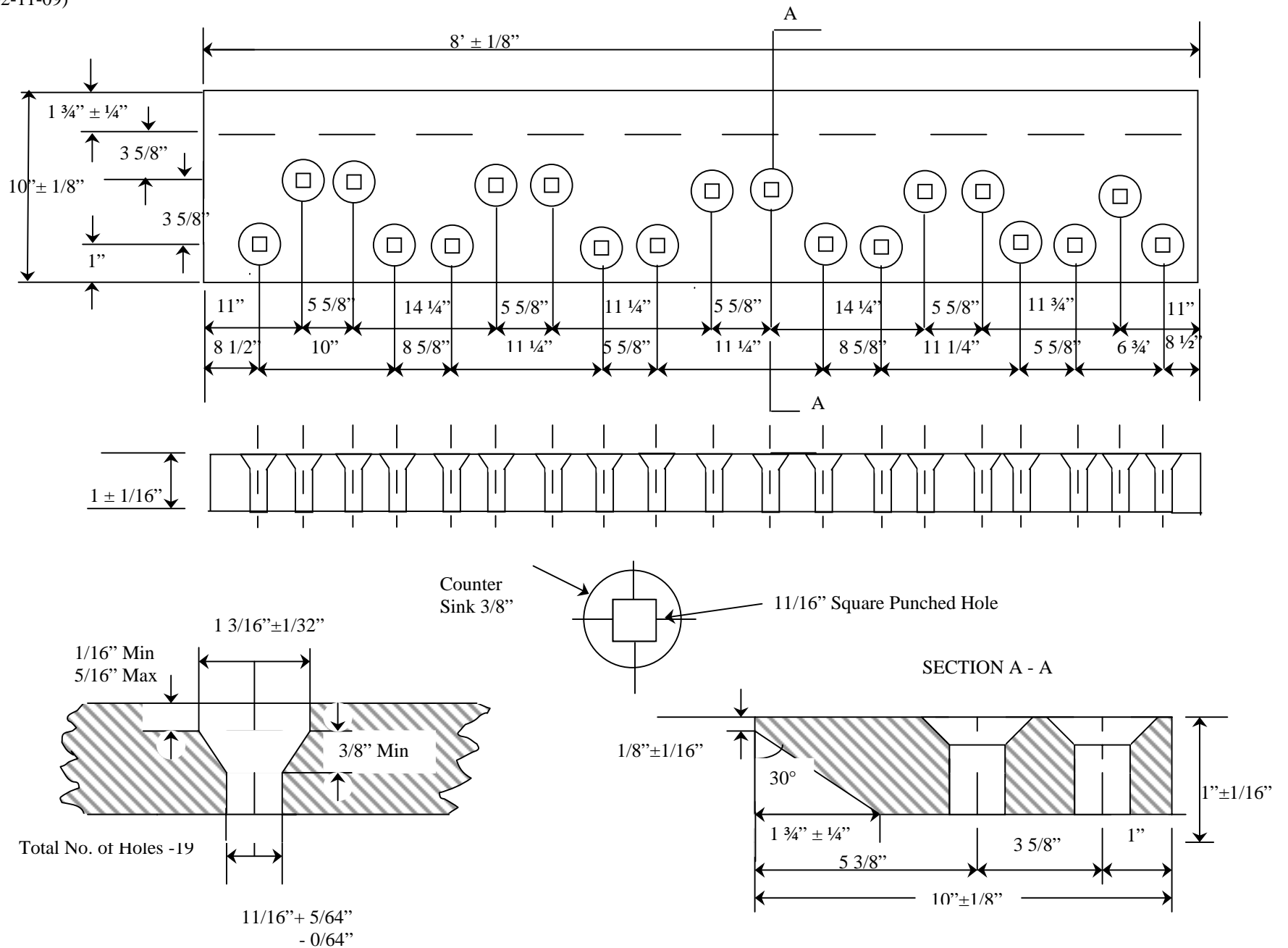

Plan of Front-End Loader Blade

NOTE: For Use of $5/8'' \times 2''$ or $3''$ Square Deep
 Countersunk No.3 Head Plow Bolt

NOTE: This drawing not to scale. Follow Dimensions

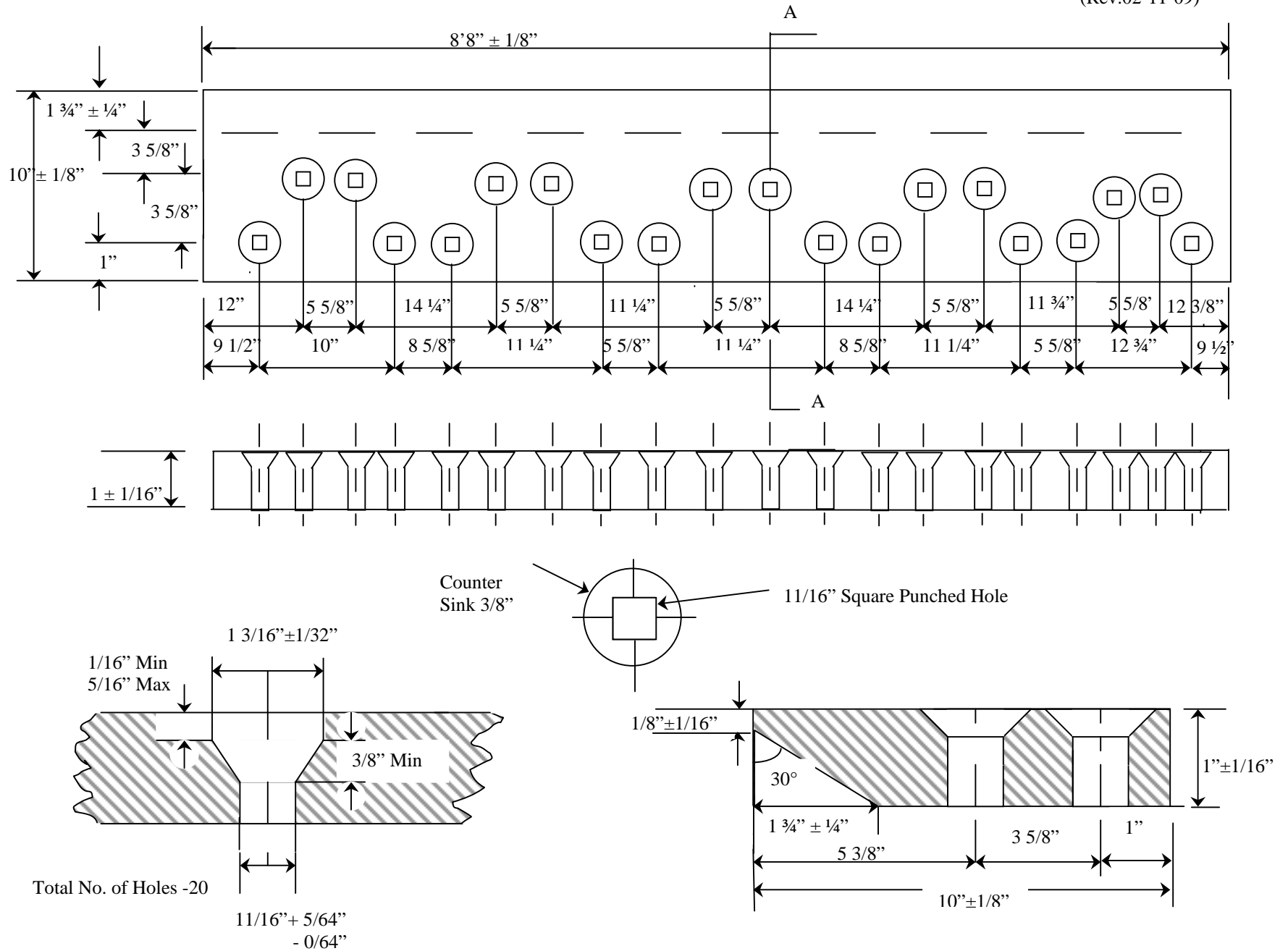

Counter Sink $3/8''$

$11/16''$ Square Punched Hole

Total No. of Holes -20

Plan of Front-End Loader Blade

NOTE: For Use of $5/8'' \times 2''$ or $3''$ Square Deep Countersunk No.3 Head Plow Bolt

NOTE: This drawing not to scale. Follow Dimensions



CARBIDE TIPPED SNOWPLOW BLADES MGS-91-01Q

1.0 DESCRIPTION. This specification covers steel snowplow blades with tungsten carbide inserts.

2.0 MATERIALS.

2.1 Steel. The blades shall be fabricated from hot rolled carbon steel meeting the requirements of either ASTM A 576-90b or ASTM A 575-89 within the range of Grades 1020 through 1044.

2.2 Tungsten Carbide Inserts. The inserts shall be a high shock WC Grade of tungsten carbide.

2.2.1 The inserts shall meet Virgin Tungsten Carbide quality specifications and shall meet the following requirements.

2.2.1.1 Insert Characteristics:

Specification	Requirement
Cobalt Content, percent	10.5 - 12.5
Density, g/cm ³ (ASTM B 311)	14.1 - 14.6
Hardness (ASTM B 294, Rockwell A Scale)	87.0 - 89.0

2.2.2 The inserts shall be rectangular design with the following dimensions:

2.2.2.1 Insert Dimensions:

Specification	Requirement
Height, inch	0.760 ± 0.010
Width, inch	0.365 ± 0.010
Length, inch, nominal	1

2.3 Finished Blades.

2.3.1 Insert Placement. The groove for the carbide shall be milled in the center of the steel blade edge. The groove shall be milled to a depth that will allow the inserts to be brazed flush with the bottom edge of the blade. The tungsten carbide inserts shall be positioned in the milled groove with approximately 0.010-inch space between the inserts the entire length of each cutting edge section. Each insert shall be one-inch nominal length. It may be necessary for some of the inserts to be different than the one-inch nominal length to make up for the spacing between the inserts. The number of inserts shall be no less than one or more than three from the number required for one insert per inch of blade length.

2.3.2 Brazing. The inserts shall be brazed on all contact surfaces consistent with sound brazing practice with no evidence of voids or use of shims. Brazing shall be of such strength and quality as required to prevent movement or loss of the inserts during use.

2.3.3 Physical Requirements. All blades shall be straight and free from flaws and injurious defects, and shall have workmanlike finish. All inserts shall be flush with the bottom angle of the

blade with a tolerance of $\pm 1/32$ inch.

2.3.3.1 The finished blade sections shall be free of warpage and longitudinal deviation shall not exceed $5/32$ inch in a five-foot long blade section, $1/8$ inch in a four-foot long blade section or $3/32$ inch in a three-foot long blade section. The edge that rests upon the pavement shall be straight and true. The longitudinal warp and the alignment of this edge shall be measured by extending a straight edge from one end of the blade to the other and measuring from the straight edge to the blade at the mid-point of length.

2.3.3.2 The difference between the highest and lowest insert shall not exceed $1/32$ inch on any given blade assembly.

2.3.3.3 Punching shall be $11/16$ -inch square holes with a $1-5/32$ inch diameter countersink $3/8$ inch deep to receive $5/8$ -inch diameter plow bolts. Details, location, and spacing of the holes shall be as shown on the attached drawing.

2.3.3.4 Moldboards are punched with holes $1/8$ inch larger than the blade bolts. Accordingly, blade punching will be of such accuracy, both for the spacing between holes and for the spacing between the end hole and the end of the blade, that the blades will fit the moldboards, thus making the blade sections interchangeable.

2.3.4 Any paint used to coat the blades shall be dry prior to shipment and shall not smear or track during handling.

3.0 CERTIFICATION AND ACCEPTANCE.

3.1 Prior to approval and use of any material delivered, the manufacturer shall submit to State Construction and Materials Engineer, P.O. Box 270, Jefferson City, Missouri 65102, (Fax 573-751-8682) a certification in duplicate certifying the grade of steel used in fabricating the blade and certifying that the blades supplied conform to all requirements of these specifications. (See certification statement)

3.1.1 The "Certification Statement" form shown in Section 5.0 is to be used when certifying. The certification shall include or have attached specific results of test performed on the tungsten carbide inserts for cobalt content, density, and hardness and showing the standard test designation of the test specified for each of these properties. The certification shall show the purchase order number, destination, and quantity of material represented at each destination and shipping date.

3.2 Acceptance of the blades and carbide tip inserts shall be based on the manufacturer's certification and upon the results of tests as may be performed on random samples of the material. When samples are taken, one complete blade of each length shall be taken to represent the shipment. A shipment will be considered as all blades represented on one certification and shipped on one date, regardless of various destinations. The carbide tip inserts shall be sampled from the blades selected for testing.

3.2.1 If a blade fails to meet any of the specified requirements, two additional blades will be selected for retest from the same quantity represented by that certification. Both of these retest samples must meet all requirements or the entire quantity will be rejected.

3.2.2 If the carbide tip inserts fail to meet any of the specified requirements, two additional samples will be selected either from the original blade sampled or from other blades contained in the same quantity represented by that certification. Both of these retest samples must meet all requirements or the entire quantity will be rejected.

3.3 If the blades are rejected, no payment will be made and the cost of blades destroyed during sampling and testing shall be borne by the supplier.

4.0 TEST METHOD MODOT T21 DETERMINATION OF COBALT IN TUNGSTEN CARBIDE INSERTS.

4.1 This method describes a procedure for determining the percent of Cobalt in Tungsten Carbide Inserts used in Snowplow Blades, using a Inductively Coupled Plasma Optical Emission Spectrophotometer (ICP-OES). The specification may be accessed at

http://epg.modot.mo.gov/index.php?title=106.7.21_TM21%2C_Determination_of_Cobalt_in_Tungsten_Carbide_Inserts

5.0 CERTIFICATION STATEMENT/BILL OF LADING.

CERTIFICATION STATEMENT
CARBIDE TIPPED SNOWPLOW BLADES

Send to:
State Construction and Materials Engineer
P.O. Box 270
Jefferson City, MO 65102
Fax – 573-751-8682

Dear Sir:

We hereby certify that the carbide tipped snowplow blades described below comply with all requirements of Specification [MGS-91-01Q](#) and in accordance with bid request No. _____.

The following blades manufactured by _____ are covered by this certification.

Bill of Lading

Purchase Order No.	Destination	Quantity & Size	Shipping Date

Following are results of tests performed on these blades:

Certification Grade of Steel in the Blade: _____

Cobalt Content in Carbide Tip: _____ Test Method: _____

Density of Carbide Tip: _____ Test Method: _____

Hardness of Carbide Tip: _____ Test Method: _____

Certified By: _____

Title: _____

Date: _____

Results of tests may be shown on attachments rather than on this form, if preferred.

This form is to be completed, signed, and submitted in duplicate for each shipment (send to address above), at the same time as blades are shipped. A shipment is defined as all blades represented on one certification and shipped on one date, regardless of various destinations.

2 – 12-inch Spaces for 3-foot Blade
 3 – 12-inch Spaces for 4-foot Blade
 4 – 12-inch Spaces for 5-foot Blade

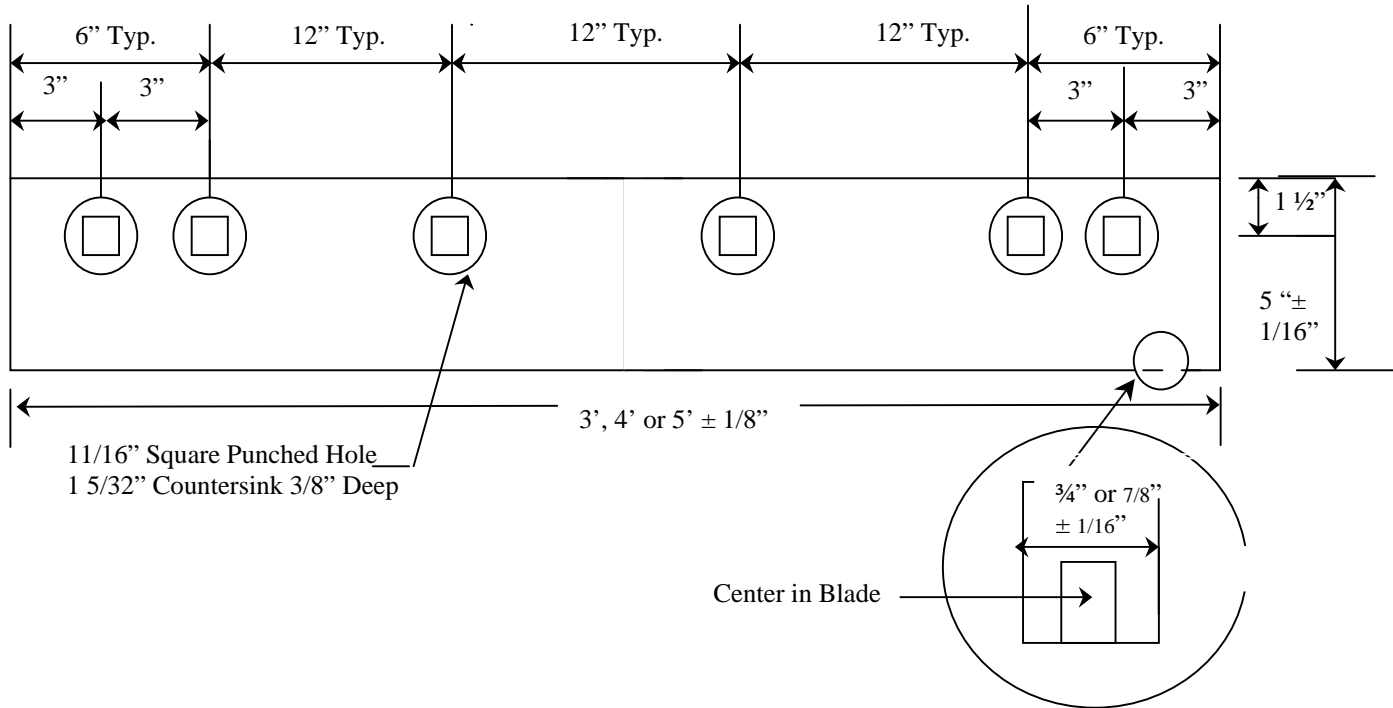

11/16" Square Punched Hole
 1 5/32" Countersink 3/8" Deep

Center in Blade

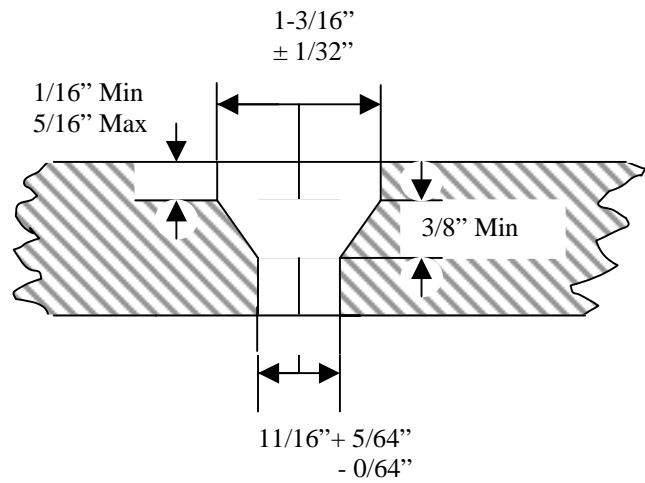
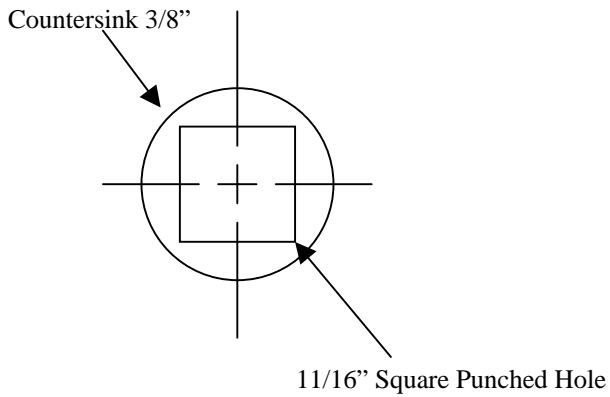

NOTE: This drawing not to scale.
 Follow Dimensions.

Plan of Carbide Tipped Snow Plow

Missouri Highways and Transportation Commission
Standard Bid Provisions, General Terms and Conditions and Special Terms and Conditions

STANDARD SOLICITATION PROVISIONS

- a. The solicitation for the procurement of the supplies referenced therein, to which these "Standard Bid Provisions, General Terms and Conditions and Special Terms and Conditions" are attached, is being issued under, and governed by, the provisions of Title 7 – Missouri Department of Transportation, Division 10 – Missouri Highways and Transportation Commission, Chapter 11 – Procurement of Supplies, of the Code of State Regulations. The Missouri Highways and Transportation Commission (**MHTC**), acting by and through its operating arm, the Missouri Department of Transportation (**MoDOT**), draws the Bidder's attention to said 7 CSR 10-11 for all the provisions governing solicitation and receipt of bids/quotes and the award of the contract pursuant to this solicitation.
- b. All bids/quotes must be signed with the firm name and by a responsible officer or employee. Obligations assumed by such signature must be fulfilled.

GENERAL TERMS AND CONDITIONS

Definitions

Capitalized terms as well as other terms used but not defined herein shall have the meaning assigned to them in section 7 CSR 10-11.010 Definition of Terms.

Nondiscrimination

- a. The Contractor shall comply with all state and federal statutes applicable to the Contractor relating to nondiscrimination, including, but not limited to, Chapter 213, RSMo; Title VI and Title VII of Civil Rights Act of 1964 as amended (42 U.S.C. Sections 2000d and 2000e, *et seq.*); and with any provision of the "Americans with Disabilities Act" (42 U.S.C. Section 12101, *et seq.*)
- b. **Sanctions for Noncompliance:** In the event of the Contractor's noncompliance with the nondiscrimination provisions of this contract, MHTC shall impose such contract sanctions as it or the Federal Highway Administration may determine to be appropriate, including, but not limited to:
 - i. withholding of payments to the Contractor under the contract until the Contractor complies, and/or,
 - ii. cancellation, termination or suspension of the contract, in whole or in part.

Contract/Purchase Order

- a. By submitting a bid/quote, the Bidder agrees to furnish any and all equipment, supplies and/or services specified in the solicitation documents, at the prices quoted, pursuant to all requirements and specifications contained therein.
- b. A binding contract shall consist of: (1) the solicitation documents, amendments thereto, and/or Best and Final Offer (BAFO) request(s) with any changes/additions, (2) the Contractor's bid response, and (3) the MHTC's acceptance of the bid by post-award contract or purchase order.
- c. A notice of award does not constitute an authorization for shipment of equipment or supplies or a directive to proceed with services. Before providing equipment, supplies and/or services, the Contractor must receive a properly authorized notice to proceed and/or purchase order.

Applicable Laws and Regulations

- a. The contract shall be construed according to the laws of the State of Missouri. The Contractor shall comply with all local, state, and federal laws and regulations related to the performance of the contract. The exclusive venue for any legal proceeding relating to or arising, out of the contract shall be in the Circuit Court of Cole County, Missouri.
- b. The Contractor must be registered and maintain good standing with the Secretary of State of the State of Missouri, Missouri Department of Revenue, and other regulatory agencies, as may be required by law or regulations. Prior to the issuance of a purchase order and/or notice to proceed, the Contractor may be required to submit to MHTC a copy of their current Authority Certificate from the Secretary of State of the State of Missouri and/or a copy of their Certificate of No Tax Due from the Missouri Department of Revenue.
- c. Prior to the issuance of a purchase order and/or notice to proceed, all **out-of-state** Contractors **providing services** within the state of Missouri must submit to MHTC a copy of their current Transient Employer Certificate from the Missouri Department of Revenue, in addition to a copy of their current Authority Certificate from the Secretary of State of the State of Missouri.

Executive Order:

The Contractor shall comply with all the provisions of Executive Order 07-13, issued by the Honorable Matt Blunt, Governor of Missouri, on the sixth (6th) day of March, 2007. This Executive Order, which promulgates the State of Missouri's position to not tolerate persons who contract with the state engaging in or supporting illegal activities of employing individuals who are not eligible to work in the United States, is incorporated herein by reference and made a part of this Agreement.

- 1) "By signing this Agreement, the Contractor hereby certifies that any employee of the Contractor assigned to perform services under the contract is eligible and authorized to work in the United States in compliance with federal law."
- 2) In the event the Contractor fails to comply with the provisions of the Executive Order 07-13, or in the event the Commission has reasonable cause to believe that the contractor has knowingly employed individuals who are not eligible to work in the United States in violation of federal law, the Commission reserves the right to impose such contract sanctions as it may determine to be appropriate, including but not limited to contract cancellation, termination or suspension in whole or in part or both.
- 3) The Contractor shall include the provisions of this paragraph in every subcontract. The Contractor shall take such action with respect to any subcontract as the Commission may direct as a means of enforcing such provisions, including sanctions for noncompliance.

Preferences

- a. In the evaluation of bids/quotes, preferences shall be applied in accordance with 7 CSR 10-11.020(7). Contractors should apply the same preferences in selecting subcontractors. The attached document entitled "**VENDOR INFORMATION AND PREFERENCE CERTIFICATION FORM**" must be completed and returned with the solicitation documents.
- b. Bidders are encouraged to obtain minority business enterprise (MBE) and women business enterprise (WBE) participation in this work through the use of subcontractors, suppliers, joint ventures, or other arrangements that afford meaningful participation for M/WBEs. Bidders are encouraged to obtain 10% MBE and 5% WBE participation.

Missouri Highways and Transportation Commission
Standard Bid Provisions, General Terms and Conditions and Special Terms and Conditions

Cancellation of Contract

The MHTC may cancel the Contract at any time for a material breach of contractual obligations or for convenience by providing Contractor with written notice of cancellation. Should the MHTC exercise its right to cancel the contract for such reasons, cancellation will become effective upon the date specified in the notice of cancellation sent to the Contractor.

Bankruptcy or Insolvency

Upon filing for any bankruptcy or insolvency proceeding by or against the Contractor, whether voluntarily, or upon the appointment of a receiver, trustee, or assignee, for the benefit of creditors, the Commission reserves the right and sole discretion to either cancel the Agreement or affirm the Agreement and hold the Contractor responsible for damages.

Warranty

The Contractor expressly warrants that all equipment, supplies, and/or services provided shall: (1) conform to each and every specification, drawing, sample or other description which was furnished to or adopted by the MHTC, (2) be fit and sufficient for the purpose expressed in the solicitation documents, (3) be merchantable, (4) be of good materials and workmanship, and (5) be free from defect.

Status of Independent Contractor

The Contractor represents itself to be an independent Contractor offering such services to the general public and shall not represent itself or its employees to be an employee of the MHTC. Therefore, the Contractor shall assume all legal and financial responsibility for taxes, FICA, employee fringe benefits, workers' compensation, employee insurance, minimum wage requirements, overtime, etc., and agrees to indemnify, save and hold the MHTC, its officers, agents and employees harmless from and against any and all losses (including attorney fees) and damage of any kind related to such matters.

Non-Waiver

If one of the parties agrees to waive its right to enforce any term of this Contract, that party does not waive its right to enforce such term at any other time or to enforce any or all other terms of this Contract.

Indemnification

The Contractor shall defend, indemnify and hold harmless MHTC, including its members and department employees, from any claim or liability whether based on a claim for damages to real or personal property or to a person for any matter relating to or arising out of the Contractor's performance of its obligations under the contract awarded pursuant to this solicitation.

Missouri Highways and Transportation Commission
Standard Bid/Proposal Provisions, General Terms and Conditions and Special Terms and Conditions

SPECIAL TERMS AND CONDITIONS

Insurance

The Contractor shall maintain or cause to be maintained at Contractor's own expense commercial general liability, automobile liability, worker's compensation insurance against negligent acts, errors or omissions of the Contractor, or its subcontractors and anyone directly or indirectly employed by any of them. Any insurance policy required as specified in this Section shall be written by a company that is licensed and authorized to issue such insurance in the state of Missouri and shall provide insurance coverage for not less than the following limits of liability:

- 1) General Liability: Not less than \$500,000 for any one person in a single accident or occurrence, and not less than \$3,000,000 for all claims arising out of a single occurrence;
- 2) Automobile Liability: Not less than \$500,000 for any one person in a single accident or occurrence, and not less than \$3,000,000 for all claims arising out of a single occurrence;
- 3) Missouri State Workmen's Compensation policy or equivalent in accordance with state law.

Upon request from the Commission, the Contractor shall provide the Commission with certificates of insurance evidencing the required coverage and that such insurance is in effect.

Holidays

- a. The following days shall be construed as **official holidays** under the terms of the contract:

January 1	New Year's Day
Third Monday in January	Martin Luther King, Jr.'s Birthday
February 12	Lincoln's Birthday
Third Monday in February	Washington's Birthday
May 8	Truman's Birthday
Last Monday in May	Memorial Day
July 4	Independence Day
First Monday in September	Labor Day
Second Monday in October	Columbus Day
November 11	Veteran's Day
Fourth Thursday in November	Thanksgiving Day
December 25	Christmas Day

- b. When any of the above **holidays falls** on a **Sunday**, the holiday will be observed on the following **Monday**; when any of the above **holidays falls** on a **Saturday**, the **holiday** will be observed on the immediately preceding **Friday**.

Missouri Department of Transportation District Map

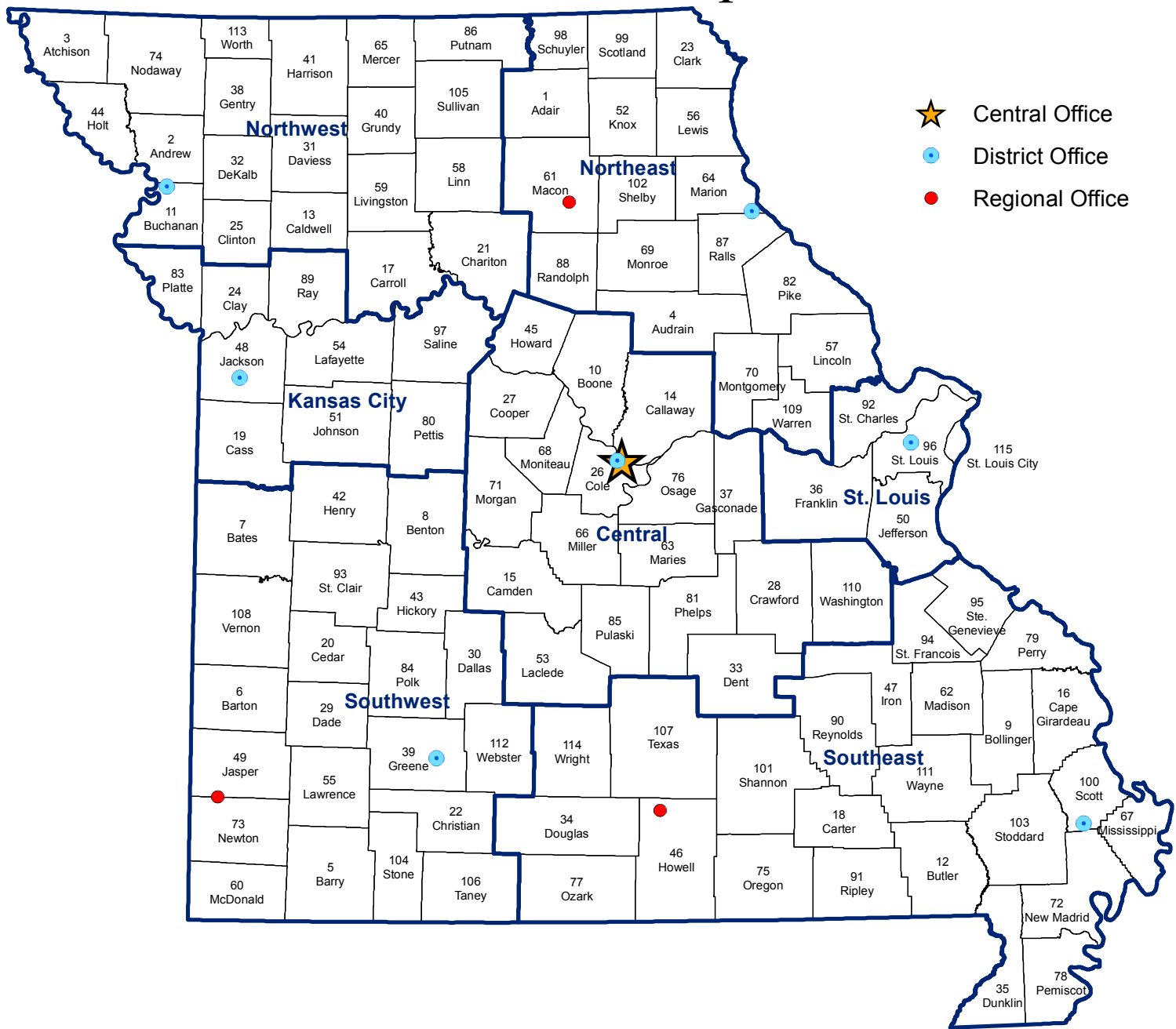

County	No. Dist.	County	No. Dist.	County	No. Dist.	County	No. Dist.	County	No. Dist.	County	No. Dist.						
Adair	1	NE	Chariton	21	NW	Harrison	41	NW	Macon	61	NE	Phelps	81	C	Shannon	101	SE
Andrew	2	NW	Christian	22	SW	Henry	42	SW	Madison	62	SE	Pike	82	NE	Shelby	102	NE
Atchison	3	NW	Clark	23	NE	Hickory	43	SW	Maries	63	C	Platte	83	KC	Stoddard	103	SE
Audrian	4	NE	Clay	24	KC	Holt	44	NW	Marion	64	NE	Polk	84	SW	Stone	104	SW
Barry	5	SW	Clinton	25	NW	Howard	45	C	Mercer	65	NW	Pulaski	85	C	Sullivan	105	NW
Barton	6	SW	Cole	26	C	Howell	46	SE	Miller	66	C	Putnam	86	NW	Taney	106	SW
Bates	7	SW	Cooper	27	C	Iron	47	SE	Mississippi	67	SE	Ralls	87	NE	Texas	107	SE
Benton	8	SW	Crawford	28	C	Jackson	48	KC	Moniteau	68	C	Randolph	88	NE	Vernon	108	SW
Bollinger	9	SE	Dade	29	SW	Jasper	49	SW	Monroe	69	NE	Ray	89	KC	Warren	109	NE
Boone	10	C	Dallas	30	SW	Jefferson	50	SL	Montgomery	70	NE	Reynolds	90	SE	Washington	110	C
Buchanan	11	NW	Daviess	31	NW	Johnson	51	KC	Morgan	71	C	Ripley	91	SE	Wayne	111	SE
Butler	12	SE	Dekalb	32	NW	Knox	52	NE	New Madrid	72	SE	St. Charles	92	SL	Webster	112	SW
Caldwell	13	NW	Dent	33	C	Laclede	53	C	Newton	73	SW	St. Clair	93	SW	Worth	113	NW
Callaway	14	C	Douglas	34	SE	Lafayette	54	KC	Nodaway	74	NW	St. Francois	94	SE	Wright	114	SE
Camden	15	C	Dunklin	35	SE	Lawrence	55	SW	Oregon	75	SE	Ste. Genevieve	95	SE	St. Louis City	115	SL
Cape Girardeau	16	SE	Franklin	36	SL	Lewis	56	NE	Ozark	76	C	St. Louis	96	SL			
Carroll	17	NW	Gasconade	37	C	Lincoln	57	NE	Pemiscot	77	SE	Saline	97	KC			
Carter	18	SE	Gentry	38	NW	Linn	58	NW	Perry	78	SE	Schuyler	98	NE			
Cass	19	KC	Greene	39	SW	Livingston	59	NW	Stoddard	100	SE	Scotland	99	NE			
Cedar	20	SW	Grundy	40	NW	McDonald	60	SW	Pettis	80	KC	Scott	100	SE			

