

Standard Drawing Guidance (do not show on plans):

To display the strand details open the reference files dialog box and activate the display option of the file with the description that best matches what is required by the design.

See EPG for actual length of B1 bars which vary by size.

The details of the coil ties are for closed diaphragms. See EPG for details required with open diaphragms.

① This detail only needs to be used if the structure is over water. For all other crossings remove this detail.

② Remove if #5-B1 bars are used.

gdr1_type2_2-8 Effective: Nov. 2015 Supercedes: Aug. 2008

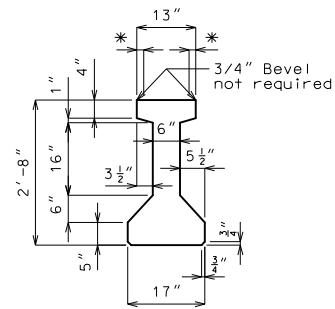

GIRDER DIMENSIONS

Concrete for prestressed girders shall be Class A-1 with $f'c =$ psi and $f'ci =$ psi.

(+) indicates prestressing strand.

Use strands with an initial prestress force of kips.

Prestressing tendons shall be uncoated, seven-wire, low-relaxation strands, 1/2 inch diameter in accordance with AASHTO M 203, Grade 270. Pretensioned members shall be in accordance with Sec 1029.

* At contractor's option a 1 1/2" to 1 3/4" smooth finish strip is permitted to facilitate placement of preformed fiber expansion joint material or expanded or extruded polystyrene bedding material for the prestressed panels.

** At the contractor's option the location for bent-up strands may be varied from that shown for fully bonded strands only. The total number of bent-up strands shall not be changed. One strand tie bar is required for each layer of bent-up strands except at end bents which require one bar on the bottom layer of strands only. No additional payment will be made if additional strand tie bars are required.

€ GIRDER STRAND ARRANGEMENTS

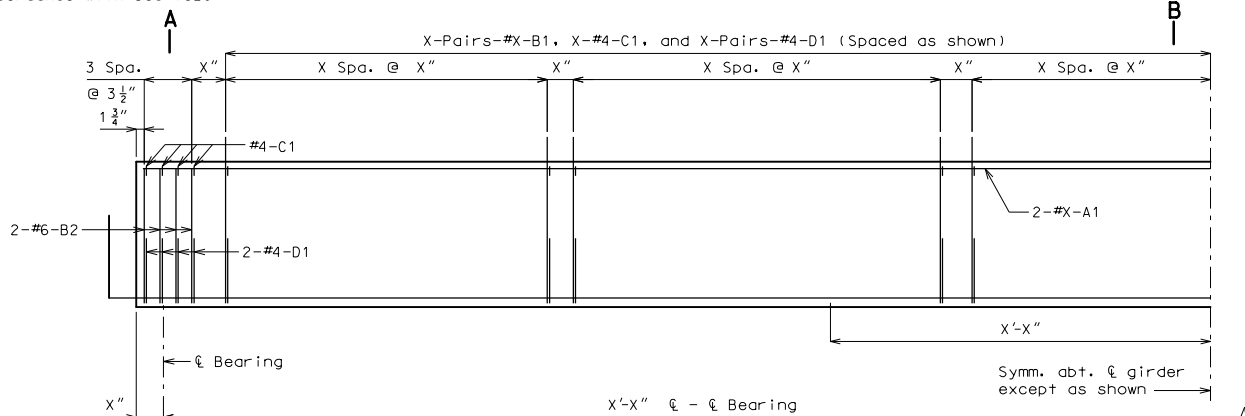

END BENT STRAND DETAILS AT GIRDER ENDS INTERMEDIATE BENT STRAND DETAILS AT GIRDER ENDS

LOCATION OF LIFTING LOOPS

BILL OF REINFORCING STEEL - EACH GIRDER			
NO.	SIZE & MARK	ACTUAL LENGTH	SHAPE
XXX	X A1	X'-X"	20
XXX	X B1	X'-X"	11
16	6 B2	3'-5"	11
XXX	4 C1	13"	10
XXX	4 D1	2'-3"	9

Fabricator shall be responsible for location and design of lifting devices.

"THIS MEDIA SHOULD NOT BE CONSIDERED A CERTIFIED DOCUMENT."

DATE PREPARED 10/30/2018	
ROUTE BR	STATE MO
DISTRICT BR	SHEET NO. *
COUNTY *	
JOB NO. *	
CONTRACT ID.	
PROJECT NO.	
BRIDGE NO. GDR1	

All dimensions are out to out.

Hooks and bends shall be in accordance with the CRSI Manual of Standard Practice for Detailing Reinforced Concrete Structures, Stirrup and Tie Dimensions.

Actual lengths are measured along centerline of bar to the nearest inch.

Minimum clearance to reinforcing shall be 1".

All reinforcement shall be Grade 60.

The two D1 bars may be furnished as one bar at the fabricator's option.

All B1 bars shall be epoxy coated.

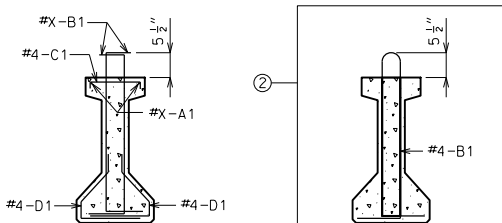

SECTION B-B
Strands not shown for clarity.

B1 BAR PERMISSIBLE ALTERNATE SHAPE

Cost of 3/4"Ø coil tie rods placed in diaphragms will be considered completely covered by the contract unit price for Prestressed Concrete I-Girder.

Coil ties shall be held in place in the forms by slotted wire-setting-studs projecting through forms. Studs are to be left in place or replaced with temporary plugs until girders are erected, then replaced by coil tie rods.

For location of coil inserts at slab drains, see Sheet No. .

For location of coil ties at concrete bent diaphragms, see Sheets No. & .

The 1 1/2"Ø holes shall be cast in the web for steel intermediate diaphragms. Drilling is not allowed. For location of holes and details of steel intermediate diaphragms, see Sheet No. .

For Girder Camber Diagram, see Sheet No. .

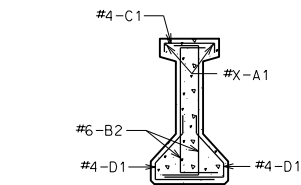

SECTION A-A
Strands not shown for clarity.

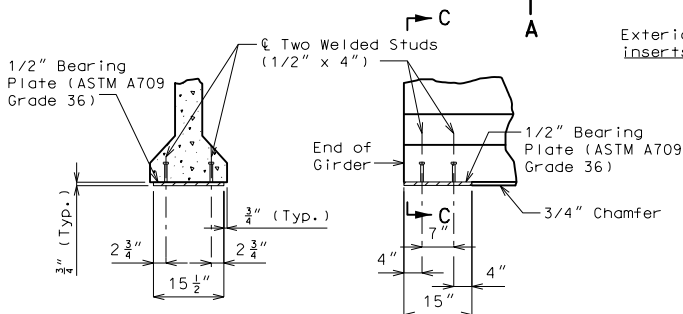

SECTION C-C PART ELEVATION AT END OF GIRDER

BEARING PLATE DETAILS

Galvanize the 1/2" bearing plate (ASTM A709 Grade 36) in accordance with ASTM A123.

Cost of furnishing, galvanizing, and installing the 1/2" bearing plate (ASTM A709 Grade 36) and welded studs in the prestressed girder will be considered completely covered by the contract unit price for Prestressed Concrete I-Girder.

HALF ELEVATION OF GIRDER SPAN (-)

Exterior and interior girders are the same, except for coil ties, and coil inserts for slab drains and holes for steel intermediate diaphragms.

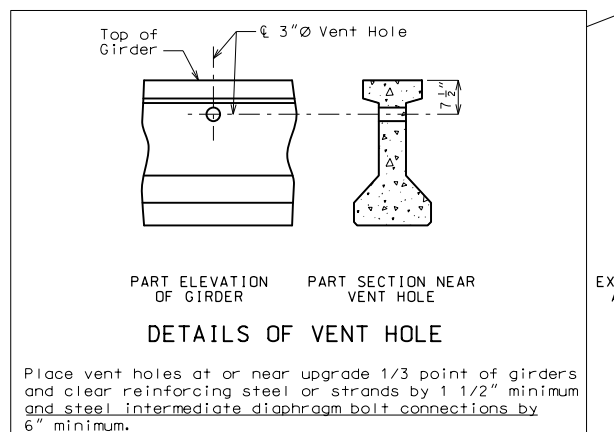

DETAILS OF VENT HOLE

Place vent holes at or near upgrade 1/3 point of girders and clear reinforcing steel or strands by 1 1/2" minimum and steel intermediate diaphragm bolt connections by 6" minimum.

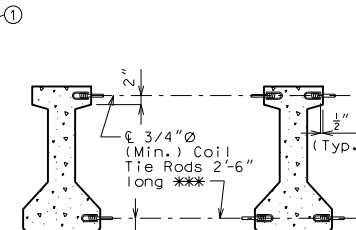

DETAILS OF COIL TIES

*** Length of coil tie rods at exterior face of exterior girders at end bents = 'L'.

Detailed Checked

Note: This drawing is not to scale. Follow dimensions.

Sheet No. of

MISSOURI HIGHWAYS AND TRANSPORTATION COMMISSION



105 WEST CAPITOL JEFFERSON CITY, MO 65102 1-888-ASK-MDOT (1-888-215-6636)

IF A SEAL IS PRESENT ON THIS SHEET IT HAS BEEN ELECTRONICALLY SEALED AND DATED.