

PLAN VIEW

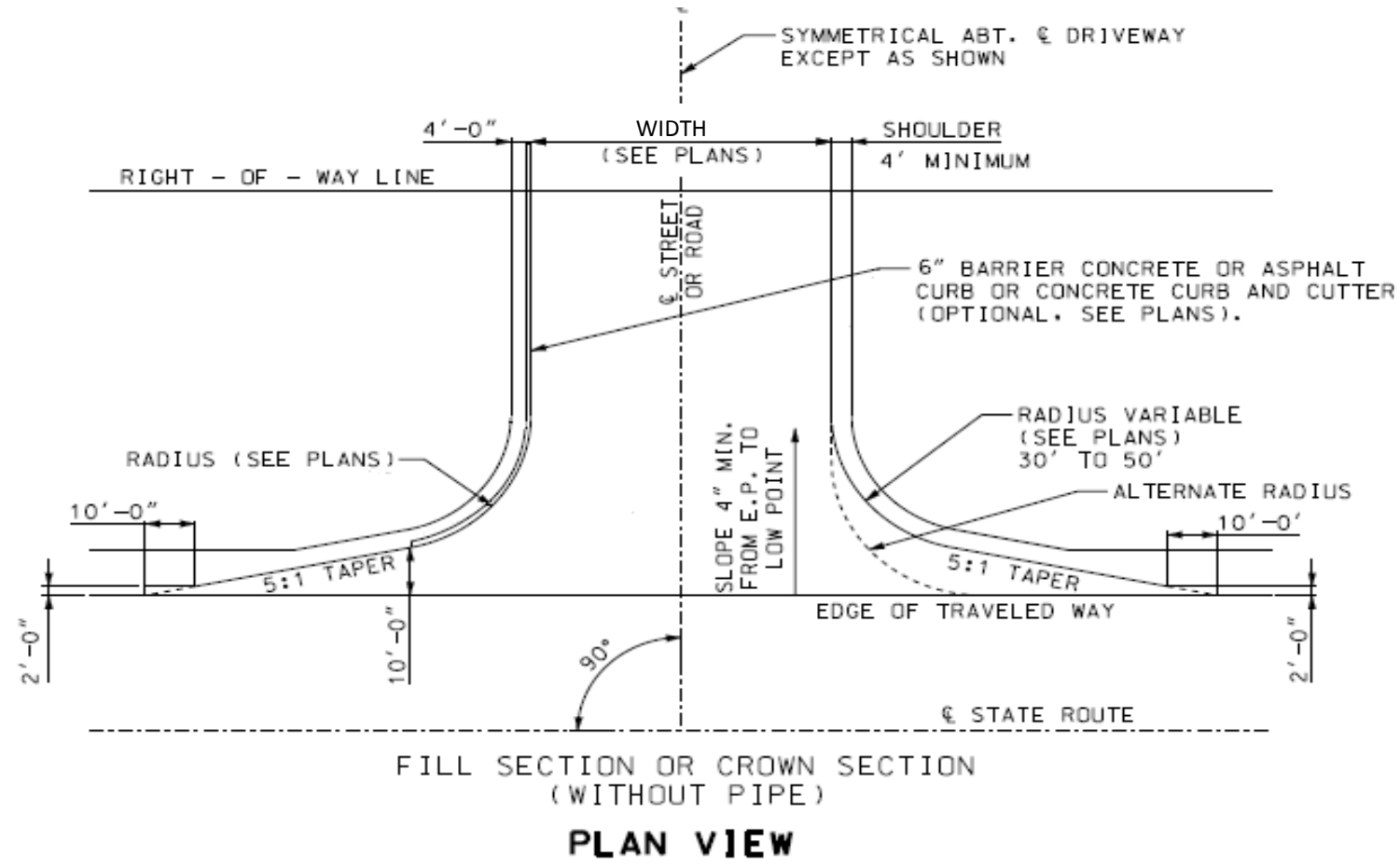

PLAN VIEW

GENERAL NOTES:

Pipe size & location to be determined by geometrics & drainage conditions (see plans).

A minimum 100 foot sight distance triangle measured along the centerline of the intersecting roadways should be provided.

Surfacing shall be shown on the plans and / or permit.

Length of pipe shall be determined by depth and location of ditch. (see plans)

If a paved approach is required, refer to standard plan 608.00 for construction details and construct curb to meet curb on paved approach.

Curb or curb and gutter between right of way line and pipe may meet local agency standards.

This drawing illustrates driveway details for minimum situations. Traffic volumes generated, safety considerations, drainage considerations, local requirements, etc. may dictate more extensive improvements than those illustrated on this drawing.

 MISSOURI DEPARTMENT of TRANSPORTATION	
D6 PERMITS	TYPE II DRIVE SIDE ROAD
RECOMMENDED WIDTHS 24' NO PARKING ON RD 32' WITH PARKING ON RD	
SHEET NO. 1 OF 2	

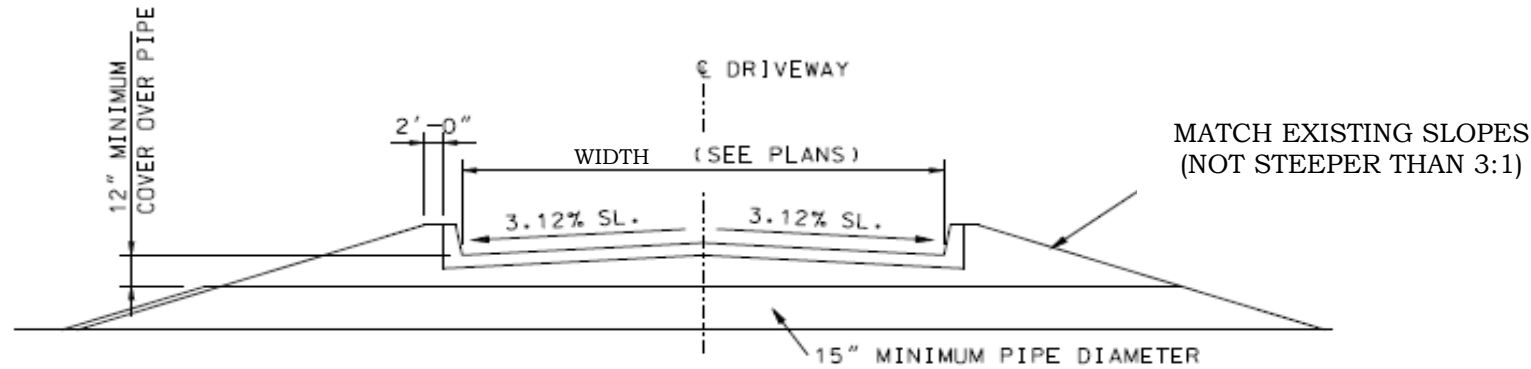
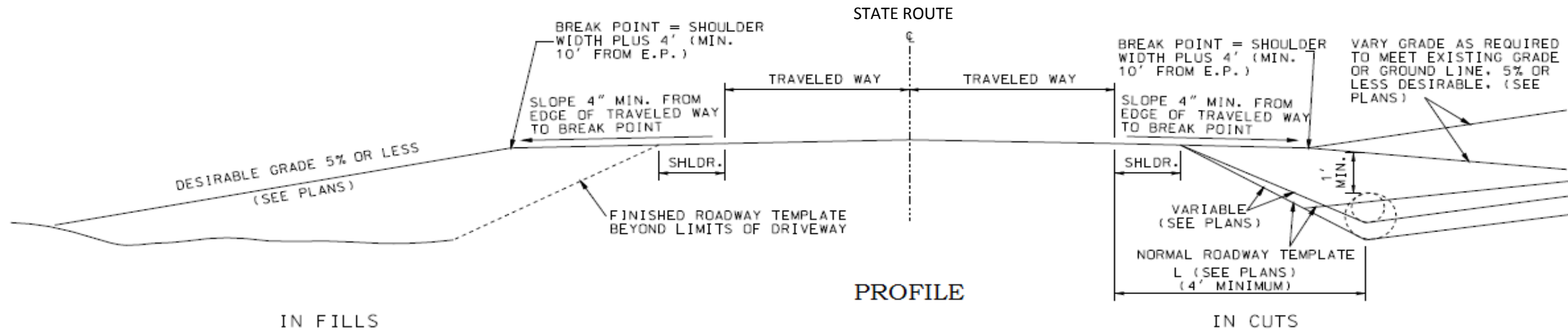

DRIVEWAY TYPICAL SECTION

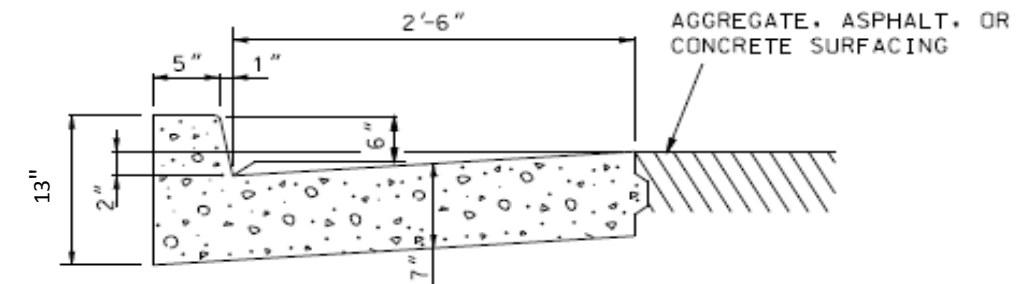

SECTION THROUGH CONCRETE CURB & GUTTER

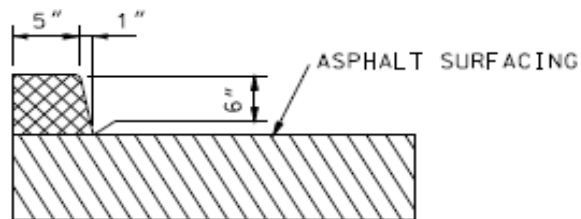

SECTION THROUGH ASPHALT CURB

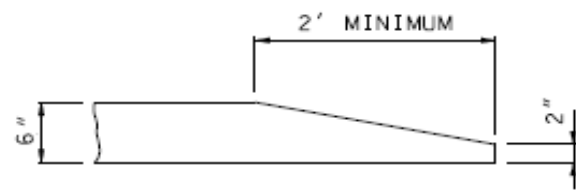

CURB TERMINAL DETAIL

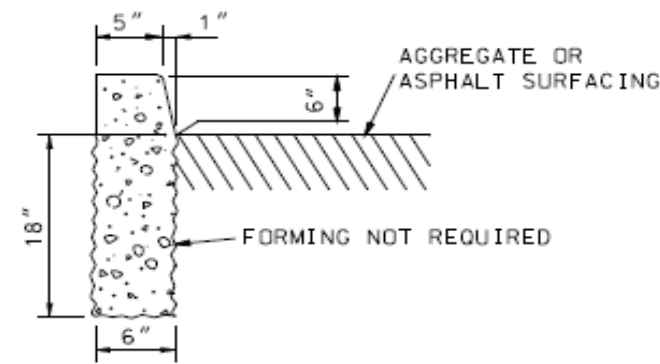

SECTION THROUGH TYPE S CURB

 MISSOURI DEPARTMENT of TRANSPORTATION	
D6 PERMITS	TYPE II DRIVE SIDE ROAD
RECOMMENDED WIDTHS 24' NO PARKING ON RD 32' WITH PARKING ON RD	
SHEET NO. 2 OF 2	