



Mayor Timothy J. Lowery

Federal Projects
STP-5622 (602)

CITY OF FLORISSANT, MISSOURI
955 RUE ST. FRANCOIS
FLORISSANT, MISSOURI 63031

REQUEST FOR BID

BID OF

MoDOT Vendor Number: _____

Bidder Name: _____

Bidder Address: _____

FOR
CONSTRUCTING

**RUE ST. DENIS IMPROVEMENTS – PHASE I
BETWEEN ST. FERDINAND STREET AND N LAFAYETTE STREET
FLORISSANT, MISSOURI**

PREPARED BY



411 North 10th Street, Suite 200
St. Louis, Missouri 63101

ADVERTISEMENT FOR ROAD WORK

Notice to Contractors

Sealed bids for Federal Project No. STP-5622 (602) " Rue Saint Denis Street – Phase I Road Improvements" will be received by the City of Florissant, City Hall, 955 Rue Saint Francois, Florissant, Missouri 63031, until 10:00 o'clock A.M. local time on the 16th day of September, 2024 and at that time will be publicly opened and read. All bids shall be submitted in the form of paper copies.

The proposed scope of work includes along Rue St. Denis Street from St. Ferdinand Street to N Lafayette Street and along N Jefferson Street from Rue St. Denis Street to Rue St. Antoine Street, consisting of coldmilling and resurfacing the roadway, installing new concrete curb and gutter, new concrete sidewalk including ADA compliant curb ramps, storm sewer, raised intersections, decorative lighting, landscaping, pavement markings, retaining walls, and other appurtenances.

Plans and specifications may be obtained from Drexel Technologies, 60 Progress Parkway, Maryland Heights, MO 63043 / www.drexeltech.com / 314-872-0900. A non-refundable fee will be charged.

All labor used in the construction of this public improvement shall be paid a wage no less than the prevailing hourly rate of wages of work of a similar character in this locality as established by the Department of Labor and Industrial Relations (Federal Wage Rate), or state wage rate, whichever is higher.

The City of Florissant hereby notifies all bidders that it will affirmatively ensure that in any contract entered into pursuant to this advertisement, businesses owned and controlled by socially and economically disadvantaged individuals will be afforded full opportunity to submit bids in response to this invitation and will not be discriminated against on the grounds of race, color, religion, creed, sex, age, ancestry, or national origin in consideration for an award."

All bidders must be on MoDOT's Qualified Contractor List per Section 102.2 of the current version of the Missouri Standard Specifications for Highway Construction including all revisions. The contractor questionnaire must be on file 7 days prior to bid opening.

Contractors and sub-contractors who sign a contract to work on public works project provide a 10-Hour OSHA construction safety program, or similar program approved by the Department of Labor and Industrial Relations, to be completed by their on-site employees within sixty (60) days of beginning work on the construction project.

A certified cashier's check or a bid bond in the amount of 5% shall be submitted with each proposal.

The City of Florissant reserves the right to reject any or all bids. The project will be awarded to the lowest, responsive, responsible bidder.

The DBE Goal for this project is 8%.

No second-tier subcontracting will be allowed on this project.

**BIDDER CHECKLIST
FINAL CHECKLIST BEFORE SUBMITTING BID**

- 1. Submit completed Contractor Questionnaire and/or Contractor Prequalification Questionnaire with attachments not later than seven (7) days prior to the date and hour of the bid opening. See Secs 101-103 of the Standard Specifications, and Rule 7 CSR 10-15.900, "Prequalifications to Bid of Certain Contractors". Questionnaire and Contact information are provided on MoDOT's website. (if applicable – required on highway and bridge projects)
- 2. For submittal of paper bids, the complete set of bidding documents includes all information through the DBE forms (for DBE forms see #7). The Technical Specifications/Job Special Provisions are for the bidder's information only and is not to be returned with the bid.
- 3. If submitting the bid by mail, it is to be completed, executed, and submitted in a sealed envelope addressed to City of Florissant, Missouri. **Provide the vendor name, vendor address, vendor number, county, route and federal project number on the outside of the envelope.**
- 4. Please read all items in the bidding document carefully. For paper bids, complete all items in ink or by typing in the information.
- 5. Sign this bidding document properly. If submitted in the name of a firm or corporation, the legal name of the firm or corporation should appear in the space designated and be signed for by one or more persons legally qualified to execute papers in the name of said firm or corporation. Affix Corporate Seal if the Bidder is a Corporation.
- 6. For paper bids submit a bid bond executed by bidder and surety, or attach cashier's check to the bid bond form.
- 7. Submit the DBE Identification Submittal within 3 business days of the Bid Opening.
- 8. For paper bids, staple addenda to the bid in the appropriate part of the bid. The letter accompanying the addenda should be stapled to the inside of the back cover of the bid and returned. The bidder should retain a duplicate copy. (if applicable)

.....
Below is a list of common mistakes made by bidders leading to non-responsive bids. Please refer to the Standard Specifications for the appropriate procedures for completing and submitting a bid.

- a) Not signing the bid
- b) Not incorporating the addendum into the bidding documents, including attaching the letter to the bid
- c) Not providing a bid bond
- d) Using pencil to fill out the bid
- e) Using white out to make corrections to the itemized bid sheets
- f) Not initialing changes made

.....
All questions concerning the bid document preparation can be directed in writing to Lochmueller Group. 411 North 10th Street Suite 200, St. Louis, MO 63101, cwilcox@lochgroup.com

Special Needs: If you have special needs addressed by the Americans with Disabilities Act, please notify the Josh Schwenk, at 314-421-4220 or through Missouri Relay System, TDD 1-800-735-2966, at least five (5) working days prior to the bid opening.

TABLE OF CONTENTS

Job Special Provisions
Form FHWA 1273 (Fig. 136.9.7)
Federal Aid Provisions
Applicable State Wage Rates
Applicable Federal Wage Rates
ADA Checklist (Fig. 136.9.4)
Environmental Clearance Documentation
Land Disturbance Permit Information
Contract Forms

NOTICE TO CONTRACTORS

Sealed bids, addressed to the City of Florissant, Attn: Ms. Karen Goodwin, City Clerk, 955 Rue Saint Francois, Florissant, Missouri 63031 for the proposed work will be received by the City of Florissant, City Hall, until 10:00 o'clock A.M. local time on the 16th day of September, 2024 and at that time will be publicly opened and read. All bids shall be submitted in the form of paper copies.

(1) PROPOSED WORK: The proposed work, hereinafter called the work, includes:

The proposed scope of work includes along Rue St. Denis Street from St. Ferdinand Street to N Lafayette Street and along N Jefferson Street from Rue St. Denis Street to Rue St. Antoine Street, consisting of coldmilling and resurfacing the roadway, installing new concrete curb and gutter, new concrete sidewalk including ADA compliant curb ramps, storm sewer, raised intersections, decorative lighting, landscaping, pavement markings, retaining walls, and other appurtenances.

(2) COMPLIANCE WITH CONTRACT PROVISIONS: The bidder, having examined and being familiar with the local conditions affecting the work, and with the contract, contract documents, including the current version of the Missouri Highways and Transportation Commission's "Missouri Standard Specifications for Highway Construction," and "Missouri Standard Plans for Highway Construction", their revisions, and the request for bid, including appendices, the special provisions and plans, hereby proposes to furnish all labor, materials, equipment, services, etc., required for the performance and completion of the work. All references are to the Missouri Standard Specifications for Highway Construction, as revised, unless otherwise noted.

The following documents are available on the Missouri Department of Transportation web page at www.modot.org under "Doing Business with MoDOT" "Standards and Specifications". The effective version shall be determined by the letting date of the project.

General Provisions & Supplemental Specifications

Supplemental Revisions to Missouri Standard Plans For Highway Construction (if applicable)

These supplemental bidding documents contain all current revisions to the bound printed versions and have important legal consequences. It shall be conclusively presumed that they are in the bidder's possession, and they have been reviewed and used by the bidder in the preparation of any bid submitted on this project.

Please note that within the above-listed documents, the term "Commission" shall be replaced with the term, "City of Florissant" and the term "Engineer" is a reference to the Engineer of Record from Lochmueller Group.

The contracting authority for this contract is the City of Florissant, Missouri.

(3) PERIOD OF PERFORMANCE: If the bid is accepted, the bidder agrees that work shall be diligently prosecuted at such rate and in such manner as, in the judgment of the engineer, is necessary for the completion of the work within the time specified as follows in accordance with Sec 108:

Calendar Days: 190

(4) **LIQUIDATED DAMAGES:** The bidder agrees that, should the bidder fail to complete the work in the time specified or such additional time as may be allowed by the engineer under the contract, the amount of liquidated damages to be recovered in accordance with Sec 108 and 136.9.4.1.1.2 (23 CFR 635.127) shall be \$1,100 per day.

(5) **BID GUARANTY:** The bidder shall submit a Bid Guaranty. The project bid bond form is included in the bid book. The bidder shall mark the box below to identify the type of Bid Guaranty.

Paper Bid Bond

Cashier's Check

The Bid Bond attached, without endorsement, in the sum of not less than five percent (5%) of the amount of the Proposal is furnished to the Owner as a guarantee that the Contract will be executed and a Contract Bond and Insurance Coverage will be furnished within fifteen (15) calendar days after award of the Contract to the Undersigned.

Within fifteen (15) calendar days after being awarded the Contract, the Undersigned agrees to execute the form of the Contract, included as one of the Contract Documents, and to furnish a Contract Bond in an amount equal to 100% of the contract amount to insure the proper and prompt completion of the work in accordance with the provisions of the contract and to insure payment for all labor performed and material consumed or used in the work, and to furnish certificates of insurance. The certificates of insurance shall list the City of Florissant as additionally insured.

(6) **CERTIFICATION FOR FEDERAL JOBS:** By signing and submitting this bid, the bidder makes the certifications appearing in Sec. 102.18.1 (regarding affirmative action and equal opportunity), Sec. 102.18.2 (regarding disbarment, eligibility, indictments, convictions, or civil judgments), Sec. 102.18.3 (regarding anti-collusion), and Sec. 102.18.4 (regarding lobbying activities). Any necessary documentation is to accompany the bid submission, as required by these sections. As provided in Sec. 108.13, the contracting authority may terminate the contract for acts of misconduct, which includes but is not limited to fraud, dishonesty, and material misrepresentation or omission of fact within the bid submission.

(7) **ANTIDISCRIMINATION:** The Contracting Authority hereby notifies all bidders that it will affirmatively insure that in any contract entered into pursuant to this advertisement, businesses owned and controlled by socially and economically disadvantaged individuals will be afforded full opportunity to submit bids in response to this invitation and will not be discriminated against on the grounds of race, color, religion, creed, sex, age, ancestry, or national origin in consideration for an award.

(8) **FEDERAL AND STATE INSPECTION:** The Federal Government is participating in the cost of construction of this project. All applicable Federal laws, and the regulations made pursuant to such laws, shall be observed by the contractor, and the work will be subject to the inspection of the appropriate State or Federal Agency in the same manner as provided in Sec 105.10 of the Missouri Standard Specifications for Highway Construction with all revisions applicable to this bid and contract.

(9) **PREVAILING WAGE (FEDERAL AND STATE):** This contract requires payment of the prevailing hourly rate of wages for each craft or type of work required to execute the contract as determined by the Missouri Department of Labor and Industrial Relations and requires adherence to a schedule of minimum wages as determined by the United States Department of Labor. For work performed anywhere on this project, the contractor and the contractor's subcontractors shall pay the higher of these two applicable wage rates. The applicable state wage rates for this contract are detailed in "Annual Wage Order No. 26", that is attached to this bidding document. The applicable federal wage rates for this contract are the effective Davis-Bacon federal wage

rates posted the tenth day before the bid opening date and are attached herein.

These supplemental bidding documents have important legal consequences. It shall be conclusively presumed that they are in the bidder's possession, and they have been reviewed and used by the bidder in the preparation of any bid submitted on this project.

(10) WORKER ELIGIBILITY REQUIREMENTS: Execution of the construction contract for this project is dependent upon the awarded bidder providing an Affidavit of Compliance AND E-Verify Memorandum-of-Understanding (MOU) between the bidder and Department of Homeland Security to the Contracting Authority as required by section 285.530 RSMo.

A sample Affidavit of Compliance can be found at the Missouri Attorney General's website at the following link:

https://ago.mo.gov/docs/default-source/pdf-forms/affidavit_of_compliance.pdf?sfvrsn=2

All bidders must also be enrolled in the E-Verify Program and include their MOU prior to contract execution. Bidders who are not enrolled will need to go to the following website link and select "Enroll in the Program" to get started. After completing the program, they will receive their E-Verify MOU with the Department of Homeland Security. This document will need to be printed out and kept on file so that a copy can be attached to the Affidavit of Compliance.

http://www.dhs.gov/files/programs/gc_1185221678150.shtm

This requirement also applies to subcontractors and contract labor, but this contract only requires submittal of the verification documents for the prime contractor. It is the prime contractor's responsibility to verify the worker eligibility of their subcontractors in order to protect their own company from liability as required by section 285.530 RSMo.

(11) OSHA TEN HOUR TRAINING REQUIREMENTS: Missouri Law, 292.675 RSMO, requires any awarded contractor and its subcontractor(s) to provide a ten-hour Occupational Safety and Health Administration (OSHA) Construction Safety Program (or a similar program approved by the Missouri Department of Labor and Industrial Relations as a qualified substitute) for their on-site employees (laborers, workmen, drivers, equipment operators, and craftsmen) who have not previously completed such a program and are directly engaged in actual construction of the improvement (or working at a nearby or adjacent facility used for construction of the improvement). The awarded contractor and its subcontractor(s) shall require all such employees to complete this ten-hour program, pursuant to 292.675 RSMO, unless they hold documentation on their prior completion of said program. Penalties, for Non-Compliance include contractor forfeiture to the Contracting Authority in the amount of \$2,500, plus \$100 per contractor and subcontractor employee for each calendar day such employee is employed beyond the elapsed time period for required program completion under 292.675 RSMO.

(12) BUY AMERICA REQUIREMENTS: Construction contracts shall assure compliance with Section 165 of the Surface Transportation Assistance Act of 1982, Section 337 of the Surface Transportation and Uniform Relocation Assistance Act of 1987, and 23 CFR 635.410 regarding Buy America provisions on the procurement of foreign products and materials. On all contracts involving Federal-aid, all products of iron, steel, or a coating of steel which are incorporated into the work must have been manufactured in the United States. The Contracting Authority may allow minimal amounts of these materials from foreign sources, provided the cost does not exceed 0.1 percent of the contract sum or \$2,500, whichever is greater. The Contractor certifies that these materials are of domestic origin.

(13) ADDENDUM ACKNOWLEDGEMENT: The undersigned states that all addenda (if applicable) have been received, acknowledged and incorporated into their bid, prior to submittal. For paper bids, staple addenda to the bid in the appropriate part of the bid.

(14) SIGNATURE AND IDENTITY OF BIDDER: The undersigned states that the following provided information is correct and that (if not signing with the intention to bind themselves to become the responsible and sole bidder) they are the agent of, and they are signing and executing this, as the bid of

_____, which is the correct LEGAL NAME as stated on the contractor questionnaire.

a) The organization submitting this bid is a(n) (1) individual bidder, (2) partnership, (3) joint venturer (whether individuals or corporations, and whether doing business under a fictitious name), or (4) corporation. Indicate by marking the appropriate box below.

sole individual partnership joint venture

corporation, incorporated under laws of state of

b) If the bidder is doing business under a fictitious name, indicate below by filling in the fictitious name

Executed by bidder this _____ day of _____ 20____.

THE BIDDER CERTIFIES THAT THE BIDDER AND ITS OFFICIALS, AGENTS, AND EMPLOYEES HAVE NEITHER DIRECTLY NOR INDIRECTLY ENTERED INTO ANY AGREEMENT, PARTICIPATED IN ANY COLLUSION, OR OTHERWISE TAKEN ANY ACTION IN RESTRAINT OF FREE COMPETITIVE BIDDING IN CONNECTION WITH THIS BID, AND THAT THE BIDDER INTENDS TO PERFORM THE WORK WITH ITS OWN BONAFIDE EMPLOYEES AND SUBCONTRACTORS, AND DID NOT BID FOR THE BENEFIT OF ANOTHER CONTRACTOR.

THE BIDDER ACKNOWLEDGES THAT THIS IS AN UNSWORN DECLARATION, EXECUTED UNDER PENALTY OF PERJURY UNDER THE LAWS OF THE UNITED STATES AND/OR FALSE DECLARATION UNDER THE LAWS OF MISSOURI, AND ANY OTHER APPLICABLE STATE OR FEDERAL LAWS. THE FAILURE TO PROVIDE THIS CERTIFICATION IN THIS BID MAY MAKE THIS BID NON-RESPONSIVE, AND CAUSE IT TO BE REJECTED.

THE BIDDER CERTIFIES THAT THE BIDDER'S COMPANY KNOWINGLY EMPLOYS ONLY INDIVIDUALS WHO ARE AUTHORIZED TO WORK IN THE UNITED STATES IN ACCORDANCE WITH APPLICABLE FEDERAL AND STATE LAWS AND ALL PROVISIONS OF MISSOURI EXECUTIVE ORDER NO. 07-13 FOR CONTRACTS WITH THE CONTRACTING AUTHORITY.

Check this box ONLY if the bidder REFUSES to make any or all of these certifications. The bidder may provide an explanation for the refusal(s) with this submittal.

Signature of Bidder's Owner, Officer, Partner or Authorized Agent

Please print or type name and title of person signing here

Attest:

Secretary of Corporation if Bidder is a Corporation

Affix Corporate Seal (If Bidder is a Corporation)

NOTE: If bidder is doing business under a fictitious name, the bid shall be executed in the legal name of the individual, partners, joint ventures, or corporation, and registration of fictitious name filed with the secretary of state, as required by sections 417.200 to 417.230 RSMo. If the bidder is a corporation not organized under the laws of Missouri, it shall procure a certificate of authority to do business in Missouri, as required by section 351.572 et seq RSMo. A certified copy of such registration of fictitious name or certificate of authority to do business in Missouri shall be filed with the Missouri Highways and Transportation Commission, as required by the standard specifications.

(15) TRAINEES: By submitting this bid, the bidder certifies that the bidder is familiar with the Training Provision in the Missouri Highways and Transportation Commission's "General Provisions and Supplement Specifications" which are available on the Missouri Department of Transportation web page at www.modot.org under "Doing Business with MoDOT" "Standards and Specifications". The number of trainee hours provided under this contract will be 0 slots at 1000 hours per slot or 0 hours.

(16) SUBCONTRACTOR DISCLOSURE: Requirements contained within Sec 102.7.8 of the Missouri Standard Specification for Highway Construction shall be waived for this contract.

(17) PROJECT AWARD: This project will be awarded to the lowest, responsive, responsible bidder.

(18) MATERIALS INSPECTIONS: All technicians who perform, or are required by the FHWA to witness, such sampling and testing shall be deemed as qualified by virtue of successfully completing the requirements of EPG 106.18 Technician Certification Program, for that specific technical area.

(19) PRIME CONTRACTOR REQUIREMENTS: The limitation in Sec 108.1.1 of the Missouri Standard Specifications for Highway Construction that "the contractor's organization shall perform work amounting to not less than 40 percent of the total contract cost" is waived for this contract. Instead, the less restrictive terms of the Federal Highway Administration's rule at Title 23 Code of Federal Regulations (CFR) § 635.116(a) shall apply, so that the contractor must perform project work with its own organization equal to and not less than 30 percent of the total original contract price. Second-tier subcontracting will not be permitted under this contract. All other provisions in Sec 108.1.1 et seq. of the Missouri Standard Specifications for Highway Construction shall remain in full force and effect and shall continue to govern the contractor and its subcontractors, in accordance with the provisions of Title 23 CFR § 635.116.

ITEMIZED BID: The bidder should complete the following section in accordance with Sec 102.7. The bidder proposes to furnish all labor, materials, equipment, services, etc. required for the performance and completion of the work, as follows:

ITEMIZED BID SHEETS

ITEMIZED BID FORM

(PAGE 1 OF 2)

SPECIFIC ROADWAY ITEMS					
ITEM NUMBER	DESCRIPTION	QUANTITY	UNIT	UNIT PRICE	EXTENDED PRICE
2022010	REMOVAL OF IMPROVEMENTS	1	LS		
2031000	CLASS A EXCAVATION	2,234	CY		
2036000	COMPACTING EMBANKMENT	300	CY		
3040504	TYPE 5 AGGREGATE FOR BASE (4 IN. THICK)	4,907	SY		
4011209	BITUMINOUS PAVEMENT MIXTURE PG64-22, (BP-1)	21	TON		
4013000	BITUMINOUS PAVEMENT MIXTURE PG64-22 (BASE)	312	TON		
4039910A	MISC. HIGH TENSILE STRENGTH SYNTHETIC FIBER ASPHALTIC CONCRETE MIXTURE PG 70-22 (SP095CLP MIX)	315	TON		
4039910B	MISC. HIGH TENSILE STRENGTH SYNTHETIC FIBER ASPHALTIC CONCRETE MIXTURE PG 70-22 (SP125CLP MIX)	736	TON		
4071005	TACKCOAT	934	GAL		
502-11.08	CONCRETE PAVEMENT (8 IN NON-REINFORCED)	481	SY		
604-12.01	SINGLE CURB INLET, UNTRAPPED	14	EA		
604-14.01	AREA INLET, SINGLE, OPEN 1 SIDE, UNTRAPPED	3	EA		
604-19.27	MANHOLE	5	EA		
604-19.22	2-GRATE INLET, W/SIDE INTAKE UNIT, UNTRAPPED	4	EA		
604-20.30	ADJUSTING MANHOLE TO GRADE	7	EA		
604-23.06	HYDRODYNAMIC SEPARATOR (6')	1	EA		
604-90.50	REPLACE PRECAST INLET STONE AND ADJUST TO GRADE	2	EA		
608-50.07	CONCRETE PAVED APPROACH (7")	673	SY		
608-50.08	CONCRETE PAVED APPROACH (8")	168	SY		
609-10.10	CONCRETE CURB, TYPE "S"	465	LF		
609-10.53	CURB AND GUTTER, VERTICAL	4,478	LF		
6169901	TRAFFIC CONTROL	1	LS		
6181000	MOBILIZATION	1	LS		
6221001	COLDMILLING BITUMINOUS PAVEMENT FOR REMOVAL OF SURFACING (3 IN. THICK OR LESS)	5,495	SY		
6274000	CONTRACTOR FURNISHED SURVEYING AND STAKING	2	LS		
703-90.15	MODULAR BLOCK WALL (H<4')	2,434	S.F.		
726-23.12	12" CLASS III REINFORCED CONCRETE PIPE CULVERT (GASKET TYPE)	1,401	LF		
726-23.15	15" CLASS III REINFORCED CONCRETE PIPE CULVERT (GASKET TYPE)	52	LF		
726-23.18	18" CLASS III REINFORCED CONCRETE PIPE CULVERT (GASKET TYPE)	312	LF		
726-23.21	21" CLASS III REINFORCED CONCRETE PIPE CULVERT (GASKET TYPE)	61	LF		
726-90.10	MSD CLASS "A" CONCRETE FOR ENCASEMENT	1	CY		
732-00.12	12" FLARED END SECTION	1	EA		
804-20.01	AMENDED SOIL (WATER QUALITY BMP)	381	SY		
8061006	ALTERNATE DITCH CHECK	4	EA		
8061007A	CURB INLET CHECK	27	EA		
8061019	SILT FENCE	279	LF		
806-55.99	LAND DISTURBANCE PERMIT - MDNR	1	LS		

ITEMIZED BID FORM

(PAGE 2 OF 2)

SPECIFIC LANDSCAPING ITEMS					
ITEM NUMBER	DESCRIPTION	QUANTITY	UNIT	UNIT PRICE	EXTENDED PRICE
6113020	FURNISHING TYPE 2 ROCK BLANKET	29	CY		
6113040	PLACING TYPE 2 ROCK BLANKET	29	CY		
8031000A	TURF TYPE TALL FESCUE SODDING	2,787	SY		
804-10.00	TOPSOIL	312	CY		
SPECIFIC BICYCLE / PEDESTRIAN ITEMS					
ITEM NUMBER	DESCRIPTION	QUANTITY	UNIT	UNIT PRICE	EXTENDED PRICE
607-51.36	VINYL FENCE (36")	331	LF		
607-60.36	TEMPORARY FENCE (36")	153	LF		
607-99.01	REMOVE AND REINSTALL EXISTING FENCE	82	LF		
608-60.00	CONCRETE SIDEWALK	1,215	SY		
608-60.07	CONCRETE SIDEWALK, CURB RAMP (7" THICK)	129	SY		
608-60.98	TRUNCATED DOMES FOR CURB RAMPS (NEW CONSTRUCTION)	198	SF		
608-70.00	CONCRETE STEPS	40	SF		
608-90.04	EXPOSED AGGREGATE CONCRETE SIDEWALK	12	SY		
608-99.01A	DECORATIVE PAVERS	23	SY		
9029903A	WROUGHT IRON FENCE (48")	150	LF		
9029903B	ORNAMENTAL STEEL FENCE (48")	312	LF		
9029903C	ORNAMENTAL CANTILEVER GATE	1	EA		
SPECIFIC UTILITY ITEMS					
ITEM NUMBER	DESCRIPTION	QUANTITY	UNIT	UNIT PRICE	EXTENDED PRICE
603-10.20	RELOCATING WATER SERVICE VALVE AND BOX	3	EA		
603-10.21	ADJUST WATER SERVICE METER	10	EA		
603-10.25	RELOCATING WATER SERVICE METER AND BOX	9	EA		
603-99.02	WATER (ADJUSTING WATER VALVE TO GRADE)	10	EA		
603-99.32	GAS (ADJUSTING GAS VALVE TO GRADE)	4	EA		
SPECIFIC SIGNALS / LIGHTING / SIGNING / STRIPING ITEMS					
ITEM NUMBER	DESCRIPTION	QUANTITY	UNIT	UNIT PRICE	EXTENDED PRICE
6200021	PREFORMED THERMOPLASTIC PAVEMENT MARKING, LEFT/RIGHT ARROW	1	EA		
6206001C	4 IN. YELLOW STANDARD WATERBORNE PAVEMENT MARKING PAINT, TYPE P BEAD	3,452	LF		
6206000C	4 IN. WHITE STANDARD WATERBORNE PAVEMENT MARKING PAINT, TYPE P BEADS	31	LF		
6206124A	24 IN. WHITE STANDARD WATERBORNE PAVEMENT MARKING PAINT, TYPE P BEADS	412	LF		
6205902A	6 IN. WHITE HIGH BUILD WATERBORNE PAVEMENT MARKING PAINT, TYPE L BEADS	298	LF		
6209902	SPEED TABLE CHEVRON MARKING	8	EA		
9031020	CONCRETE FOOTINGS, BOLT DOWN	2	CY		
9019902A	LIGHTING POLE, 12 FT	45	EA		
9019902B	LIGHTING POLE FOUNDATION, TYPE C	45	EA		
9019902C	LUMINAIRE, POST TOP, TENON MOUNT	45	EA		
9013002	CONDUIT, 2 IN. RIGID, IN TRENCH	3,400	LF		
9014002	CONDUIT, 2 IN. RIGID, PUSHED	870	LF		
9016110	PULL BOX PREFORMED CLASS 1	15	EA		
9017110	CABLE, 12 AWG 1 CONDUCTOR, POLE AND BRACKET	1,980	LF		
9017008	CABLE, 8 AWG, 1 CONDUCTOR	14,955	LF		
9019902	PAD MOUNTED 120V/240V LIGHTING CONTROLLER	1	EA		
9031250A	U-CHANNEL POST, 3 LB	299	LF		
9035004A	SH-FLAT SHEET	216	SF		
TOTAL BASE BID					

The quantities shown on the above itemized bid form are estimated and are furnished to be used as a basis for preparing the bid and bid comparison. The City reserves the right to increase or decrease the quantities based on the submitted unit prices. Final payment will be made on the measured quantities.

RUE ST. DENIS PHASE I IMPROVEMENTS BID FORM

Route: Rue St. Denis Street County: St. Louis Agency: City of Florissant
Project No.: STP-5622 (602)

CONTRACTOR NAME _____

- ***FOR COMPLETE INFORMATION COVERING THESE ITEMS, REFERENCE PLANS & SPECIFICATIONS.***

The undersigned Bidder acknowledges receipt of the following addenda listed by number and date appearing on each addendum:

Addendum Number & Date Received:

BID BOND

KNOW ALL PERSONS BY THESE PRESENTS, that we _____

as principal and _____
as surety, are held and firmly bound unto the state of Missouri (acting by and through the Missouri Highways and Transportation Commission) in the penal sum of _____ Dollars (\$) to be paid to the commission to be credited to the state road fund, the principal and surety binding themselves, their heirs, executors, administrators, successors, and assigns, jointly and severally, firmly by these presents.

Sealed with our seals and dated this _____

THE CONDITION OF THIS OBLIGATION is such that

WHEREAS the principal is submitting herewith a bid to the commission on route(s) _____

in _____ County(ies), project (s)

_____ for construction or improvement of state highway as set out in said bid;

NOW THEREFORE, if the commission shall accept the bid of the principal and if the principal shall properly execute and deliver to the commission the contract, contract bond, and evidence of insurance coverage in compliance with the requirements of the bid, the specifications, and the provisions of section 227.100 RSMo, to the satisfaction of the commission, then this obligation shall be void and of no effect, otherwise to remain in full force and effect.

In the event the said principal shall, in the judgment of the commission, fail to comply with any requirement as set forth in the preceding paragraph, then the state of Missouri, acting by and through the commission, shall immediately and forthwith be entitled to recover the full penal sum above set out, together with court costs, attorney's fees, and any other expense of recovery.

The principal and surety hereby certify that the document is the original or a verbatim copy of the bid bond form furnished by the Commission, in accordance with Sec 102.9 of the Missouri Standard Specifications for Highway Construction.

SEAL _____
By _____
Principal
Signature

SEAL _____
By _____
Surety
Signature of Attorney in Fact

NOTE: This bond must be executed by the principal, and by a corporate surety authorized to conduct surety business in the state of Missouri.

DBE Submittal Forms

(6) **DBE Submittal Forms:** This form must be submitted by 4 p.m. three (3) business days after bid opening.

(A) DBE Contract Goal: By submitting this bid, the bidder certifies that the bidder is familiar with the DBE Program Requirements in this contract. The contract DBE goal for the amount of work to be awarded is 8% of the total federal project price. The bidder shall also complete the DBE Submittal Form in accordance with the program requirements.

(B) DBE Participation: The bidder certifies that it will utilize DBE's as follows:
_____% OF TOTAL FEDERAL CONTRACT

NOTE: Bidder must fill in the above blank. If no percentage is specified, the bidder certifies that it agrees to, and will comply with the contract goal. If a percentage below the contract goal is specified, then the bidder must submit complete documentation of good faith efforts to meet the DBE contract goal, immediately below.

(C) Certification of Good Faith Efforts to Obtain DBE Participation: By submitting its signed bid, the bidder certifies under penalty of perjury and other provisions of law, that the bidder took each of the following steps to try to obtain sufficient DBE participation to achieve the Commission's proposed DBE Contract Goal: (Attach additional sheets if necessary).

DBE Identification Submittal Form

Job Number: _____

Route: _____

Prime Contractor: _____

County: _____

Contract Amount: _____

Identification of Participating DBE's: Provide the requested information below for each DBE participating on the project. Submit this information with your bid or to Lochmueller Group no later than 4:00 p.m. on the 3rd working day after the bid opening. Fax or e-mail transmittal is permitted. The fax number is 314-621-3288 and the e-mail address for submittal is cwilcox@lochgroup.com. Contact MoDOT's External Civil Rights Division (ECR) at (573) 526-2978 for questions and assistance on completion. **This page of this document must be received for each DBE utilized on the project.**

All information must be provided.

If awarded the contract for this project, the undersigned will use the following DBE to perform or furnish the work, supplies, and/or services as shown below:

DBE Name: _____ Address: _____

(A) Line No.	(B) Dollar Value of DBE Work** (Unit Price x Quantity of the Item in (A), or Lump Sum)	(C) Dollar value applicable to DBE Goal** (100%, 60%)	(D) Dollar amount applicable to DBE Goal (B x C)	(E) Percent of total contract amount for line item (D / total contract amount)
DBE Total:			Total %	

**Cannot exceed contract amount for given item of work
 Trucking services credited at 100% if the DBE owns the trucks or is leasing from a DBE firm
 Allowed amount of participation will be in accordance with 49 CFR Part 26.
 Brokered services will only receive credit for fees.

Respectfully submitted:

 Company Name (Prime Contractor)

 Name / Title

 Signed (Prime Contractor)

**Instructions for Completing the
DBE Identification Submittal Form
(For Local Program Agency (LPA) Projects)
(ECR-101)**

Submit this form with your bid or as outlined on front of page no later than 4:00 p.m. on the 3rd working day after the bid opening. Only DBE's listed on MoDOT's Missouri Regional Certification Committee (**MRCC**) directory may be used towards obtaining the DBE goal on the project. DBE firm must be certified with the appropriate North American Industrial Classification System (**NAICS**) code for the type of work being utilized to perform. The MRCC directory is available at the following link under the MRCC Directory tab:
[HTTP://www.modot.org/welcome-external-civil-rights](http://www.modot.org/welcome-external-civil-rights)

- (A) Insert Bid Line Item in the same order as it appears in the bid document.
- (B) Insert the result from multiplying the unit price for the bid line item by the quantities listed in column (A); a lump sum, if applicable, may also be inserted.
- (C) Insert the percentage of column (B) that the DBE will perform. If the DBE is a supplier as that term is defined in 49 CFR Part 26.55, then only 60% of the value in column (B) can be applied towards the contract specific goal. If the DBE is furnishing and installing the line item, then 100% of the value can be applied.
- (D) Insert the result from dividing columns (B) and (C).
- (E) Insert the result from dividing column (D) from the total bid line item amount.

DISADVANTAGED BUSINESS ENTERPRISE (DBE) PROGRAM REQUIREMENTS FOR LOCAL PROGRAMS

1.0 Disadvantaged Business Enterprise (DBE) Program Requirements. The subsequent Sections will apply only to contracts involving U.S. Department of Transportation (USDOT) federal-aid or federal financial participation. Federal-aid or federal financial participation includes, but is not limited to, any funds directly or indirectly received by MoDOT, or authorized for distribution to or through MoDOT, by the USDOT or any operating administration within the USDOT. These provisions will not apply to Commission contracts funded exclusively with state funds, or state and local funds. Any contractor, subcontractor, supplier, DBE firm, and contract surety involved in the performance of a federal-aid contract shall be aware of and fully understand the terms and conditions of the USDOT DBE Program, as the terms appear in Title 49 CFR Part 26 (as amended), the USDOT DBE Program regulations; Title 7 CSR Division 10, Chapter 8 (as amended), the Commission's DBE Program rules.

2.0 DBE Program Distinguished From Other Affirmative Action Programs. The USDOT DBE Program established by the U.S. Congress is not the same as, and does not involve or utilize, any of the elements or authority of other state or local affirmative action programs, nor does the program rely upon state legislation or gubernatorial executive orders for implementation or authorization, other than the general authority given the Commission in Section 226.150, RSMo. The USDOT DBE Program is implemented by the Commission and MoDOT, through and in conjunction with the FHWA, FTA and FAA, as a "recipient" defined in Title 49 CFR 26.5.

3.0 Policy Regarding DBE Firms. It is the policy of the U. S. Department of Transportation and MoDOT that businesses owned by socially and economically disadvantaged individuals have an opportunity to participate in the performance of contracts financed in whole or in part with federal funds. Consequently, the requirements of 49 CFR Part 26 (as amended) and the Commission's implementing state regulations in Title 7 CSR Division 10, Chapter 8, "Disadvantaged Business Enterprise Program", will apply to any contract with federal funds.

4.0 Opportunity for DBEs to Participate. Each contractor, subcontractor and supplier working on a contract financed in whole or in part with federal funds shall take all necessary and reasonable steps to ensure that DBEs have an opportunity to compete for, and participate in performance on project contracts and subcontracts.

5.0 Required Contract Provision. The federal-aid contract will include the following provision, as mandated by USDOT at Title 49 CFR 26.13(b):

(a) The contractor, subrecipient or subcontractor shall not discriminate on the basis of race, color, national origin, or sex in the performance of the contract. The contractor shall carry out applicable requirements of 49 CFR Part 26 in the award and administration of USDOT-assisted contracts. Failure by the contractor to carry out these requirements is a material breach of the contract, which may result in the termination of the contract or such other remedy, as the recipient deems appropriate. In this provision, "contractor" will be defined as the contractor on the contract; "subrecipient" will be defined as any subcontractor performing the work. For the purposes of any federal-aid contract awarded by the Commission, "the recipient" will be defined as either the Commission, or MoDOT, or both. The contractor shall include this same contract provision in every supply contract or subcontract the contractor makes or executes with a subrecipient.

6.0 Bank Services. The contractor, and each subrecipient on a federal-aid contract, is encouraged to use the services of banks owned and controlled by socially and economically

disadvantaged individuals. Such banking services, and the fees charged for services, typically will not be eligible for DBE Program contract goal credit. Any questions on this subject should be directed to the MoDOT External Civil Rights Director. See [Sec 7.0](#).

7.0 DBE Program Information. DBE Program information may be obtained from the MoDOT External Civil Rights Director, P.O. Box 270, Jefferson City, Missouri 65102- 0270. Phone (573) 751-4309, Fax (573) 526-0558, E-Mail: dbes@modot.mo.gov. It will be the duty of each contractor, for the contractor and for the contractor's subrecipients and surety, to take the steps necessary to determine the legal obligations and limitations under the DBE Program, as an element of responsibility. It will be the duty of each certified DBE firm to know, understand and comply with the DBE firm's legal obligations and limitations under the DBE Program, as a requirement of program participation. A surety providing a bid or contract bond will be bound by those bonds to the duties of the surety's principal.

8.0 DBE Certification, and the Missouri Unified Certification Program. The Missouri Department of Transportation and other certifying agencies within Missouri have partnered to form the Missouri Regional Certification Committee (MRCC) and developed a Unified Certification Program (UCP) pursuant to 49 CFR 26.81 and 7 CSR 10-8.061. Only DBE firms certified by the MRCC are eligible to perform work on a federal-aid contract for DBE contract goal credit. It is the contractor's responsibility to ensure firms identified for participation are approved certified DBE firms.

The MRCC DBE Directory can be found at the following link:

<https://www6.modot.mo.gov/MRCC/Home/PublicSearch>

9.0 DBE Program-Related Certifications Made By Bidders and Contractors. If the bidder makes a written, express disclaimer of one or more certifications or assurances in the bid, the bid will be considered non-responsive. By submitting a bid on any call involving USDOT federal financial participation, and by entering into any contract on the basis of that bid, the contractor makes each of the following DBE Program-related certifications and assurances to USDOT, to the Commission, and to MoDOT:

(a) The bidder certifies that management and bidding officers have reviewed and understand the bidding and project construction and administration obligations of the USDOT DBE Program regulations at Title 49 CFR Part 26 (as amended), the USDOT DBE Program regulations; Title 7 CSR Division 10, Chapter 8 (as amended), and the Commission's DBE Program rules. The bidder further certifies that the contractors management personnel on the project understand and are familiar with the requirements of these federal and state DBE Program regulations; and if the bidder was not familiar with or did not understand the requirements of these regulations, they have contacted the External Civil Rights Division of MoDOT and have been informed as to their duties and obligations under the DBE Program regulations by MoDOT staff and/or by USDOT DBE Program staff.

(b) The bidder certifies that the bidder has complied with the federal and state DBE Program requirements in submitting the bid and will comply fully with these requirements in performing any federal-aid contract awarded on the basis of that bid.

(c) The bidder agrees to ensure that certified DBE firms have a full and fair opportunity to participate in the performance of the contract financed in whole or in part with federal funds. The bidder certifies that all necessary and reasonable steps were taken to ensure that DBE firms have an opportunity to compete for and perform work on the contract. The bidder further certifies that the bidder does not discriminate on the basis of race, color, age, national origin or sex in the performance of the contract, or in the award of any subcontract.

(d) The bidder certifies, under penalty of perjury and other applicable penal laws that if awarded the federal-aid contract, the contractor will make a good faith effort to utilize certified DBE firms to perform DBE work at or above the amount or percentage of the dollar value specified in the bidding documents. The bidder further certifies the bidder's understanding that the bidder may not unilaterally terminate, substitute for, or replace any DBE firm that was designated in the executed contract, in whole or in any part, with another DBE, any non-DBE firm or with the contractor's own forces or those of an affiliate of the contractor, without the prior written consent of MoDOT as set out below.

(e) The bidder certifies, under penalty of perjury and other applicable penal laws that a good faith effort was made to obtain DBE participation in the contract, at or above the DBE participation contract goal. The bidder further certifies, under penalty of perjury and other applicable penal laws, that if the bidder is not able to meet the Commission's DBE contract goal, and if the bidder is not able to meet that DBE contract goal by the time the proposed DBE participation information must be submitted, within three business days after bid opening, the bidder has submitted with and as a part of the bid, a true, accurate, complete and detailed written explanation of good faith efforts to meet the DBE Contract Goal.

(f) The bidder understands and agrees that if awarded the contract the contractor is legally responsible to ensure that the contractor and each DBE subcontractor and supplier, comply fully with all regulatory and contractual requirements of the USDOT DBE Program, and that each DBE firm participating in the contract fully perform the designated tasks, with the DBE's own forces and equipment, under the DBE's own direct supervision and management. The bidder certifies, under penalty of perjury and other applicable penal laws, that if it awarded the contract and if MoDOT or the Commission determine that the contractor, a DBE or any other firm retained by the contractor has failed to comply with the DBE Program requirements or federal or state DBE Program regulations, the Commission, through MoDOT, shall have the sole authority and discretion to determine the extent of the monetary value to which the DBE contract goals have not been met, and to assess against and withhold monetary damages from the contractor in the full amount of that breach. The Commission, through MoDOT, may impose any other remedies available at law or provided in the contract in the event of a contract breach. The bidder further understands and agrees that this clause authorizes the Commission, through MoDOT, to determine and fix the extent of the damages caused by a breach of any contractual or regulatory DBE Program requirement and that the damage assessment will be enforced in addition to, and not in lieu of, any other general liquidated damages clause in the contract. By submitting a bid for a federal-aid contract, and by entering into a contract, the bidder irrevocably agrees to such an assessment of liquidated damages for DBE Program purposes, and authorizes the Commission and MoDOT to make such an assessment of liquidated damages against the contractor, and to collect that assessment from any sums due the contractor under the contract, or any other contract, or by other legal process. The bidder makes this certification, agreement and authorization on behalf of itself, its subcontractors and suppliers, and the bid bond and contract bond sureties, for each federal-aid contract.

(g) The surety upon any bid or contract bond acknowledges the surety is held and firmly bound to the Local Agency for each and every duty of the surety's principal provided in any bid or contract regarding the DBE program.

10.0 Designation of DBE firms to perform on contract The bidder states and certifies, under penalty of perjury or other applicable penal laws, that the DBE participation information submitted in the bid or within the stated time thereafter is true, correct and complete and that the information provided includes the names of all DBE firms that will participate in the contract, the specific line item (s) that each DBE firm will perform, and the creditable dollar amounts of the participation of each DBE. The specific line item must reference the MoDOT line number and item number

contained in the proposal. The bidder further states and certifies that the bidder has committed to use each DBE firm listed for the work shown to meet the DBE contract goal and that each DBE firm listed has clearly confirmed that the DBE firm will participate in and perform the work, with the DBE's own forces. Award of the contract will be conditioned upon meeting these and other listed requirements of 49 CFR 26.53.

(a) The bidder certifies the bidder's understanding that as the contractor on a contract funded in whole or in part by USDOT federal funds, the bidder may not unilaterally terminate, substitute for, or replace any DBE firm that was designated in the executed contract, in whole or in any part, with another DBE, any non-DBE firm or with the contractor's own forces or those of an affiliate, without the prior written consent of MoDOT. The bidder understands it must receive approval in writing from MoDOT for the termination of a DBE firm, or the substitution or replacement of a DBE before any substitute or replacement firm may begin work on the project in lieu of the DBE firm participation information listed in the executed contract,

(1) The bidder further certifies understanding, that if a DBE firm listed in the bid or approved in the executed contract documents ceases to be certified at any time during the performance of the contract work, and a contract or subcontract with that firm has not yet been executed by the prime and subcontractor, the contractor cannot count any work performed by that firm after the date of the firm's loss of eligibility toward meeting the DBE contract goal. However, if the contractor has executed a subcontract with the firm before the DBE lost eligibility and ceased to be a certified DBE, the contractor may continue to receive credit toward the DBE contract goal for that firm's work.

(2) The bidder further certifies understanding, that if a DBE subcontractor is terminated, or fails, refuses or is unable to complete the work on the contract for any reason, the contractor must promptly request authority to substitute or replace that firm. The request shall include written documentation that the DBE firm is unwilling or unable to perform the specified contract work. The contractor shall make good faith efforts to find another DBE subcontractor to substitute or replace the dollar amount of the work that was to have been performed by the DBE firm. The good faith efforts shall be directed at finding another DBE to perform the same, or more, dollar amount of work that the DBE firm that was terminated was to have performed under the executed contract. The substitute or replacement DBE firm may be retained to perform the same or different contract work from that which the terminated firm was to have performed. The contractor shall obtain approval from MoDOT in writing before the replacement or termination of one firm with another before the work will count toward the project DBE goal.

(3) The bidder further certifies the bidder's understanding, that the dollar value of any work completed by a DBE firm prior to approval of the DBE's substitution or replacement, in writing, by MoDOT will not be credited toward meeting the DBE contract goal. The contractor will remain subject to appropriate administrative remedies, including but not limited to, liquidated damages for the full dollar amount that the DBE contract goal is not met. Liquidated damages will also be assessed against the contractor if the original, substitute or replacement DBE firms perform the required contract work, but are not paid in full for some or all of that work by the contractor, including back charges. No credit toward the DBE goal will be given for any amount withheld from payment to the DBE or "back charged" against monies owed to the DBE, regardless of the purpose or asserted debt.

11.0 Good Faith Effort to Secure DBE Services. The bidder shall make a good faith effort to seek DBEs in a reasonable geographic area to where the solicitation for subcontracts and material is made. If the bidder cannot meet the goals using DBEs from that geographic area, the bidder shall, as a part of the effort to meet the goal, expand the search to a wider geographic area.

11.1 Bidding Procedure. The following bidding procedure shall apply to the contract, for DBE program compliance purposes.

11.2 Contract Goal, Good Faith Efforts Specified. The bidder may submit the completed "DBE Identification Submittal" information in the bid documents at the same time as, and within the sealed bid, at the time the bid is submitted. However, if that information is not completed and submitted with the initial sealed bid, then as a matter of responsiveness and responsibility, the apparent low and second low bidder shall file the completed "DBE Identification Submittal" pages to the Local Agency on or before 4:00 p.m. of the third business day after the bid opening date. The Local Agency may permit telefax transmittal. The complete and signed original documents shall be mailed to the Local Agency no later than the day of the telefax transmission. No extension of time will be allowed for any reason. The means of transmittal and the risk of timely receipt of the information shall be the bidder's.

The bidder is responsible to ensure that all submittals are checked for accuracy. Any and all omissions, deletions, and/or errors that may affect the end result of the bid package are the sole liabilities of the bidders. The bid may be found non-responsive if the submittal is not complete and/or accurate.

11.3 Bid Rejection, Bid Security Disposition. The failure of either the apparent low bidder or the second low bidder to file the completed and executed "DBE Identification Submittal", listing actual, committed DBE participation equal to or greater than the DBE contract goal percentage specified in the bid by 4:00 p.m. on the third business day after the bid opening, will be cause for rejection of that bid, and the bid surety bond or bid guaranty of that bidder will be forfeited to and become the property of the Local Agency upon demand.

(a) Any bidder rejected for failure to submit the completed and executed "DBE Identification Submittal" information in the bidding documents, with full documentation of sufficient DBE participation to satisfy the DBE contract goal cannot submit a bid on the same, or substantially similar, project, when and if the project is re-advertised for bids. By submitting a bid on a federal-aid project, the bidder accepts and agrees to this provision, and the disposition of the bidders bid bond or guaranty, on behalf of the bidder and the bidders bid surety or guaranty.

(b) The surety separately acknowledges the surety to be held and firmly bound to the Local Agency to immediately upon demand pay the face amount of the bid bond.

11.4 Good Faith Efforts Described. Good faith efforts to meet the DBE contract goal may include, but are not limited to, the following:

(a) Attending a pre-bid meeting, if any, scheduled by the department to inform DBEs of contracting and subcontracting opportunities;

Advertising in general circulation trade association and socially and economically disadvantaged business directed media concerning subcontracting opportunities.

(b) Providing written notice to a reasonable number of specific DBEs so that the DBE's interest in the contract are solicited in sufficient time to allow the firm to participate effectively;

(c) Following-up on initial written notice or solicitations of interest by contacting DBEs to determine with certainty whether the DBEs were interested.

(d) Maintaining documentation of responses received in the effort to solicit DBE

participation.

(e) Selecting portions of work to be performed by DBEs to increase the likelihood of meeting the DBE goal, including, where appropriate, breaking down contracts into economically feasible units to facilitate DBE participation.

(f) Providing interested DBEs adequate information about plans, specifications and requirements of the contract.

(g) Negotiating in good faith with interested DBEs, not rejecting DBEs as unqualified without sound business reasons based on a thorough investigation of the DBE's capabilities.

(h) Making efforts to assist interested DBEs in obtaining bonding, lines of credit or insurance required by the Local Agency or by the bidder.

(i) Making effective use of available disadvantaged business organizations, minority bidders' groups, local, state and federal disadvantaged business assistance offices, MoDOT and other organizations that provide assistance in the recruitment and placement of DBEs.

11.5 Documentation, and Administrative Reconsideration of the Bidder's Good Faith Efforts. In the bidding documents, the bidder has the opportunity and responsibility to provide certified written documentation as to whether the bidder made a good faith effort to meet the DBE contract goal as proposed by MoDOT. Any bidder that has not met the Commission's proposed DBE contract goal at the time of bid opening must submit the completed "Certification of Good Faith Efforts to Obtain DBE Participation". The certification should be included in the bidding documents, fully and in detail, at the time its sealed bid is submitted, however, if that information is not completed and submitted with the initial sealed bid, the bidder must submit the documentation to the Local Agency on or before 4:00 p.m. of the third business day after the bid opening date. The Local Agency may permit telefax transmittal. The complete and signed original documents shall be mailed to the Local Agency no later than the day of the telefax transmission. No extension of time will be allowed for any reason. The means of transmittal and the risk of timely receipt of the information shall be the bidder's responsibility. The bidder shall attach additional pages to the certification, if necessary, in order to fully detail specific good faith efforts made to obtain certified DBE firm participation in the proposed contract work. If the apparent low bidder appears to have failed to adequately document in the bid that the bidder made a good faith effort to achieve sufficient DBE participation in the contract work, that firm will be offered the opportunity for administrative reconsideration upon written request, before the Local Agency and MoDOT reject that bid as non-responsive. However, regardless of the DBE contract goal participation level proposed by the bidder, or the extent of good faith efforts shown, the apparent low and second low bidders shall each timely and separately file their completed and executed "DBE Identification Submittal" or face potential sanctions and the bid bond or guaranty, as specified in [Sec 10.0](#) of these provisions may become the property of the Local Agency subject to the Local Agency's demand. **12.0 DBE Participation for Contract Goal Credit.** DBE participation on the contract will count toward meeting the DBE contract goal as follows:

(a) The applicable percentage of the total dollar value of the contract or subcontract awarded to the DBE will be counted toward meeting the DBE contract goal, only if that firm is certified by the MRCC as a DBE at the time the contract or subcontract is executed, and only for the value of the work, goods or services that are actually performed, or provided, by the DBE firm itself.

(b) When a DBE performs work as a participant in a joint venture, the contractor may count toward the DBE goal only that portion of the total dollar value of the contract equal to the distinct, clearly defined portion of the contract work that the DBE has performed with the DBE's own forces. The MoDOT External Civil Rights Director shall be contacted in advance regarding any joint venture involving both a DBE firm and a non-DBE firm to review and approve the contractor's organizational structure and proposed operation. When a DBE subcontracts part of the work of the contract to another firm, the value of that subcontracted work may be counted toward the DBE contract goal only if the DBE's subcontractor at a lower tier is a MoDOT certified DBE. Work that a DBE subcontracts to a non-DBE firm will not count toward the DBE contract goal. The cost of supplies and equipment a DBE subcontractor purchases or leases from the prime contractor or the prime's affiliated firms, or from another non-DBE subcontractor, will not count toward the DBE contract goal.

(c) The contractor may count expenditures to a DBE subrecipient toward the DBE contract goal only if the DBE performs a commercially useful function (CUF) on that contract.

(d) A contractor may not count the participation of a DBE subcontractor toward the contractor's final compliance with the contractor's DBE contract goal obligations until the amount being counted has actually been paid to the DBE. A contractor may count 60 percent of the contractor's expenditures actually paid for material and supplies obtained from a DBE certified by MoDOT as a regular dealer, and 100 percent of such expenditures actually paid for materials and supplies obtained from a certified DBE manufacturer.

(1) A regular dealer will be defined as a firm that owns, operates, or maintains a store, warehouse or other establishment in which the material, supplies, articles or equipment required and used under the contract are bought, kept in stock, and regularly sold or leased to the public in the usual course of business. To be a regular dealer, the DBE firm shall be an established, regular business that engages, as its principal business and under its own name, in the purchase and sale or lease of the products in question. Packagers, brokers, manufacturers' representatives, or other persons who arrange or expedite transactions will not be considered regular dealers.

(2) A DBE firm may be a regular dealer in such bulk items as petroleum products, steel, cement, gravel, stone or asphalt, without owning, operating or maintaining a place of business where it keeps such items in stock, if the DBE both owns and operates distribution equipment for the products it sells and provides for the contract work. Any supplementation of a regular dealer's own distribution equipment shall be by a long-term lease agreement, and not on an ad hoc or contract-by-contract basis.

(3) If a DBE regular dealer is used for DBE contract goal credit, no additional credit will be given for hauling or delivery to the project site goods or materials sold by that DBE regular dealer. Those delivery costs shall be deemed included in the price charged for the goods or materials by the regular dealer, who shall be responsible for their distribution.

(4) A manufacturer will be defined as a firm that operates or maintains a factory or establishment that produces on the premises, the material, supplies, articles or equipment required under the contract and of the general character described by the project specifications. A manufacturer will include firms that produce finished goods or products from raw or unfinished material, or that purchases and substantially alters goods and materials to make them suitable for construction use before reselling them.

(e) A contractor may count toward the DBE contract goal the following expenditures to

certified DBE firms that are not "regular dealers" or "manufacturers" for DBE program purposes:

(1) The contractor may count toward the DBE contract goal the entire amount of fees or commissions charged by a certified DBE firm for providing a bona fide service, such as professional, technical, consultant or managerial services, or for providing bonds or insurance specifically required for the performance of the federal-aid contract, if the fee is reasonable and not excessive, compared with fees customarily charged for similar services.

(2) The contractor may count toward the DBE contract goal the entire amount of that portion of the construction contract that is performed by the DBE's own forces and equipment, under the DBE's supervision. This includes the cost of supplies and material ordered and paid for by the DBE for contract work, including supplies purchased or equipment leased by the DBE except supplies and equipment a DBE subcontractor purchases or leases from the prime contractor or its affiliates.

(f) A contractor may count toward the DBE contract goal 100 percent of the fees paid to a certified DBE trucker or hauler for delivery of material and supplies required on a job site, but not for the cost of those materials or supplies themselves, or for the removal or relocation of excess material from or at the job site, when the DBE certified trucking company is not also the manufacturer of or a regular dealer in those material and supplies, provided that the trucking or hauling fee is determined by MoDOT to be reasonable as compared with fees customarily charged by non-DBE firms for similar services. The certified DBE trucking firm shall also perform a CUF on the project and not operate merely as a pass through for the purposes of gaining credit toward the contract DBE goal. Prior to submitting a bid, the contractor shall determine, or contact the MoDOT External Civil Rights Director for assistance in determining, whether a DBE trucking firm will meet the criteria for performing a CUF on the project.

(g) The contractor will receive DBE contract goal credit for the fees or commissions charged by and paid to a DBE broker who arranges or expedites sales, leases or other project work or service arrangements, provided that those fees are determined by MoDOT to be reasonable and not excessive, as compared with fees customarily charged by non-DBE firms for similar services. A broker will be defined as a person or firm that does not own or operate the delivery equipment necessary to transport materials, supplies or equipment to or from a job site; a broker typically will not purchase or pay for the material, supplies or equipment, and if the broker does purchase or pay for those items, those costs will be reimbursed in full. In most instances, the broker is merely the entity making arrangements for delivery of material, supplies, equipment, or arranging project services. To receive DBE contract goal credit, MoDOT must determine that the DBE broker has performed a CUF in providing the contract work or service.

13.0 Performing a Commercially Useful Function (CUF). No credit toward the DBE contract goal will be allowed for contract payments or expenditures to a DBE firm, if that DBE firm does not perform a CUF on that contract. A DBE performs a CUF when the DBE is solely responsible for execution of a distinct element of the contract work, and the DBE actually performs, manages and supervises the work involved with the firm's own forces. To perform a CUF, the DBE alone shall be responsible, and alone must bear the risk, for the material and supplies used on the contract, selecting a supplier or dealer from those available, negotiating price, determining quality and quantity, ordering the material and supplies, installing those materials with the DBE's own forces and equipment and paying for those materials and supplies. The amount the DBE firm is to be paid under the contract shall be commensurate with the work the DBE actually performs and the DBE credit claimed for the DBE's performance.

13.1 Contractor's Obligation to Monitor CUF Performance. It shall be solely the contractor's responsibility to ensure that all DBE firms perform a CUF. Further, the contractor is responsible to, and shall ensure that each DBE firm fully performs the DBE's designated tasks, with the DBE's own forces and equipment, under the DBE's own direct supervision and management. MoDOT is under no obligation to warn the contractor that a DBE's participation may not count toward the goal, other than through official notification with an opportunity for administrative reconsideration at the conclusion of the contract work.

13.2 DBEs Must Perform a Useful and Necessary Role in Contract Completion. A DBE does not perform a commercially useful function if the DBE's role is limited to that of an extra participant in a transaction, contract, or project through which funds are passed in order to obtain the appearance of DBE participation.

13.3 DBEs Must Perform The Contract Work With Their Own Workforces. If a DBE does not perform and exercise responsibility for at least 30 percent of the total cost of the DBE's contract with the DBE's own work force, or the DBE subcontracts a greater portion of the work of a contract than would be expected on the basis of normal industry practice for the type of work involved, MoDOT will presume that the DBE is not performing a commercially useful function.

13.4 Factors Used to Determine if a DBE Trucking Firm is Performing a CUF. The following factors will be used to determine whether a DBE trucking company is performing a commercially useful function (CUF):

(a) To perform a CUF, the DBE trucking firm shall be completely responsible for the management and supervision of the entire trucking operation that the DBE is being paid for on the contract work. There shall not be contrived arrangement, including but not limited to, any arrangement that would not customarily exist under regular construction project subcontracting practices for the purpose of meeting the DBE contract goal.

(b) The DBE must own and operate at least one fully licensed, insured and operational truck used in performance of the contract work. This does not include a supervisor's pickup truck or a similar vehicle that is not suitable for hauling the necessary materials or supplies.

(c) The DBE receives 100 percent contract goal credit for the total reasonable amount the DBE is paid for the transportation services provided on the contract using trucks the DBE owns, insures and operates, using drivers that the DBE employs.

(d) The DBE may lease trucks from another DBE firm, including an owner-operator who is certified as a DBE. The DBE firm that leases trucks from another DBE will receive credit for the total fair market value actually paid for of the transportation services the lessee DBE firm provides on the contract.

(e) The DBE may also lease trucks from a non-DBE firm, including an owner-operator. However, the DBE who leases trucks from a non-DBE is entitled to DBE contract goal credit only for the brokerage fee or commission the DBE receives as a result of the lease arrangement. The DBE will not receive credit for the total value of the transportation services provided by the non-DBE lessee. Furthermore, no DBE contract goal credit will be allowed, even for brokerage fees or commissions, where the DBE leases the trucks from the contractor on the project or a firm owned, controlled by, or affiliated by ownership or control to, the contractor.

(f) For purposes of this section, the lease shall indicate that the DBE firm leasing the truck has exclusive use of and control over the truck. This will not preclude the leased truck from working for others during the term of the lease with the consent of the DBE, provided the lease

gives the DBE absolute priority for and control over the use of the leased truck. Leased trucks shall display the name and identification number of the DBE firm that has leased the truck at all times during the life of that lease.

13.5 MoDOT Makes Final Determination On Whether a CUF Is Performed. MoDOT and the Commission will have the final authority to determine whether a DBE firm has performed a CUF on a federal-aid contract. To determine whether a DBE is performing or has performed a CUF, MoDOT will evaluate the amount of work subcontracted by that DBE firm or performed by other firms, and the other firms forces and equipment. Any DBE work performed by the contractor, or by employees or equipment of the contractor will be subject to disallowance under the DBE Program, unless the independent validity and need is demonstrated.

14.0 Use of Joint Checks

Request for joint checks must be made to MoDOT by the contractor. Prior approval must be given before the use of joint checks is allowed. Contact External Civil Rights Division at 573-751-4309 or dbes@modot.mo.gov to request a Joint Check Request Form.

15.0 Verification of DBE Participation, Liquidated Damages.

15.1 Prior to final payment by the Local Agency, the contractor shall file with the Local Agency a detailed list showing each DBE used on the contract work, and the work performed by each DBE. The list shall show the actual dollar amount paid to each DBE for the creditable work on the contract, less any rebates, kickbacks, deductions, withholdings or other repayments made. The list shall be certified under penalty of perjury, or other law, to be accurate and complete. MoDOT and the Commission will use this certification and other information available to determine if the contractor and the contractor's DBEs satisfied the DBE contract goal percentage specified in the contract and the extent to which the DBEs were fully paid for that work. The contractor shall acknowledge, by the act of filing the detailed list, that the information is supplied to obtain payment regarding a federal participation contract.

15.2 Failure on the part of the contractor to achieve the DBE participation to which the contractor committed in the contract may result in liquidated damages being imposed on the contractor by the Commission for breach of contract and for non-compliance. If the contract was awarded with less than the original DBE contract goal proposed by the Commission, the revised lower amount shall become the final DBE contract goal, and that goal will be used to determine any liquidated damages to be assessed. Additionally, the Commission or MoDOT may impose any other administrative sanctions or remedies available at law or provided by the contract in the event of breach by the contractor by failing to satisfy the contractor's DBE contract goal commitment. However, no liquidated damages will be assessed, and no other administrative sanctions or remedies will be imposed when, for reasons beyond the control of the contractor and despite the good faith efforts made by the contractor, the final DBE contract goal participation percentage was not achieved. The contractor will be offered the opportunity for administrative reconsideration of any assessment of liquidated damages, upon written request. The administrative reconsideration officer may consider all facts presented, including the legitimacy or business reason for back charges assessed against a DBE firm, in determining the final amount of liquidated damages.

16.0 Prompt Payment Requirements. In accordance with Title 49 CFR 26.29, the contractor shall comply with the prompt payment requirements of that regulation, Section 34.057, RSMo., the provisions of the Commission's rule 7 CSR 10-8.111 and the contract. By bidding on a federal-aid contract, and by accepting and executing that contract, the contractor agrees to assume these contractual obligations, and to bind the contractor's subrecipients contractually to those prompt payment requirements at the contractor's expense.

17.0 Miscellaneous DBE Program Requirements. In accordance with Title 49 CFR Part 26 and the Commission's DBE Program rules in Title 7 CSR Division 10, Chapter 8, the contractor, for both the contractor and for the contractor's subcontractors and suppliers, whether DBE firms or not, shall commit to comply fully with the auditing, record keeping, confidentiality, cooperation and anti-intimidation or retaliation provisions contained in those federal and state DBE Program regulations. By bidding on a federal-aid contract, and by accepting and executing that contract, the contractor agrees to assume these contractual obligations, and to bind the contractor's subrecipients contractually, at the contractor's expense.

JOB SPECIAL PROVISIONS

	CITY OF FLORISSANT 955 Rue St. Francois Florissant, MO 63131 Phone 1-314-921-5700
	Lochmueller Group, Inc. 411 North 10 th Street, Suite 200 St. Louis, MO 63101 Certificate of Authority: F00508273 Consultant Phone: (314)621-3395
	If a seal is present on this sheet, JSP's have been electronically sealed and dated.
	PROJECT NO.: STP-5622 (602): CITY OF FLORISSANT DATE PREPARED: August 20, 2024
	ADDENDUM DATE:

Only the following items of the Job Special Provisions (Roadway) are authenticated
by this seal: All

JOB SPECIAL PROVISIONS TABLE OF CONTENTS

(Job Special Provisions shall prevail over General Special Provisions whenever in conflict therewith.)

A.	General - Federal	1
B.	Contract Liquidated Damages	1
C.	Temporary Traffic Control	2
D.	Plans and Specifications	3
E.	Project Contact for Contractor/Bidder Questions	4
F.	LPA Buy America Requirements	4
G.	Emergency Provisions and Incident Management	5
H.	Utilities	6
I.	Americans With Disabilities Act (ADA) Compliance And Final Acceptance Of Constructed Facilities	8
J.	Safety Requirements	10
K.	Safety Plan	10
L.	Daily Earthwork Duty	11
M.	Field Verification	12
N.	Do Not Disturb Items	12
O.	Saw Cuts	12
P.	Earthwork	13
Q.	Truncated Domes	13
R.	Decorative Pavers	13
S.	Modular Block Wall (H<4')	15
T.	Adjust To Grade Items	15
U.	Hydrodynamic Separator (6')	15
V.	Reinforcing Fibers for Bituminous Pavement Material	16
W.	Vibratory Activities	19
X.	Install Lighting Equipment	19
Y.	Pad Mounted Power Supply	20
Z.	Wrought Iron Fence	20
AA.	Ornamental Steel Fence	21
BB.	Ornamental Cantilever Gate	23
CC.	Supplemental Revisions JSP-18-01CC	26

A. General - Federal

1.0 Description. The Federal Government is participating in the cost of construction of this project. All applicable Federal laws, and the regulations made pursuant to such laws, shall be observed by the contractor, and the work will be subject to the inspection of the appropriate Federal Agency in the same manner as provided in Sec 105.10 of the Missouri Standard Specifications for Highway Construction with all revisions applicable to this bid and contract.

1.1 This contract requires payment of the prevailing hourly rate of wages for each craft or type of work required to execute the contract as determined by the Missouri Department of Labor and Industrial Relations and requires adherence to a schedule of minimum wages as determined by the United States Department of Labor. For work performed anywhere on this project, the contractor and the contractor's subcontractors shall pay the higher of these two applicable wage rates. State Wage Rates, Information on the Required Federal Aid Provisions, and the current Federal Wage Rates are available on the Missouri Department of Transportation web page at www.modot.org under "Doing Business with MoDOT", "Contractor Resources". Effective Wage Rates will be posted 10 days prior to the applicable bid opening. These supplemental bidding documents have important legal consequences. It shall be conclusively presumed that they are in the bidder's possession, and they have been reviewed and used by the bidder in the preparation of any bid submitted on this project.

1.2 The following documents are available on the Missouri Department of Transportation web page at www.modot.org under "Doing Business with MoDOT"; "Standards and Specifications". The effective version shall be determined by the letting date of the project.

General Provisions & Supplemental Specifications

Supplemental Plans to July 2024 Missouri Standard Plans
For Highway Construction

These supplemental bidding documents contain all current revisions to the published versions and have important legal consequences. It shall be conclusively presumed that they are in the bidder's possession, and they have been reviewed and used by the bidder in the preparation of any bid submitted on this project.

B. Contract Liquidated Damages

1.0 Description. Liquidated Damages for failure or delay in completing the work on time for this contract shall be in accordance with Sec 108.8.

2.0 Calendar Days. The count of calendar days will begin on the date the contractor starts any construction operations on the project.

Job Number	Calendar Days	Daily Contract Administrative Cost
STP-5622 (602)	190	\$1100

3.0 Liquidated Damages for Contract Administrative Costs. Should the contractor fail to complete the work within the number of calendar days specified in Section 2.0, whichever occurs first, the contractor will be charged contract administrative liquidated damages in accordance with Sec 108.8 in the amount of **\$1100** per calendar day for each calendar day, or partial day thereof, that the work is not fully completed.

C. Temporary Traffic Control

1.0 Delete Sec 616.11 and insert the following:

616.11 Method of Measurement. Measurement for relocation of post-mounted signs will be made to the nearest square foot of sign area only for the signs designated for payment on the plans. All other sign relocations shall be incidental. Measurement for construction signs will be made to the nearest square foot of sign area. Measurement will be made per each for each of the temporary traffic control items provided in the contract.

616.11.1 Lump Sum Temporary Traffic Control. No measurement will be made for temporary traffic control items grouped and designated to be paid per lump sum. The list of lump sum items provided in the plans or contract is considered an approximation and may be subject to change based on field conditions. This is not a complete list and may exclude quantities for duplicate work zone packages used in simultaneous operations. The contractor shall provide all traffic control devices required to execute the provided traffic control plans for each applicable operation, stage, or phase. No measurement will be made for any additional signs or devices needed except for changes in the traffic control plan directed by the engineer.

2.0 Delete Sec 616.12 and insert the following:

616.12 Basis of Payment. All temporary traffic control devices authorized for installation by the engineer will be paid for at the contract unit price for each of the pay items included in the contract. Whether the devices are paid individually, or per lump sum, no direct payment will be made for the following:

- (a) Incidental items necessary to complete the work, unless specifically provided as a pay item in the contract.
- (b) Installing, operating, maintaining, cleaning, repairing, removing, or replacing traffic control devices.
- (c) Covering and uncovering existing signs and other traffic control devices.
- (d) Relocating temporary traffic control devices, including permanent traffic control devices temporarily relocated, unless specifically included as a pay item in the contract.
- (e) Worker apparel.
- (f) Flaggers, AFADs, PFDs, pilot vehicles, and appurtenances at flagging stations.
- (g) Furnishing, installing, operating, maintaining, and removing construction-related vehicle and equipment lighting.
- (h) Construction and removal of temporary equipment crossovers, including restoring pre-existing crossovers.
- (i) Provide and maintaining work zone lighting and work area lighting.

616.12.1 Lump Sum Temporary Traffic Control. Traffic control items grouped together in the contract or plans for lump sum payment shall be paid incrementally per Sec 616.12.1.1. Alternately, upon request from the contractor, the engineer will consider a modified payment schedule that more accurately reflects completion of traffic control work. No payment will be made for any additional signs or devices needed except for changes in the traffic control plan directed

by the engineer. Additional items directed by the engineer will be paid for in accordance with Sec 109.4. No adjustment to the price will be made for overruns or underruns of other work or for added work that is completed within existing work zones.

616.12.1.1 Partial payments. For purposes of determining partial payments, the original contract amount will be the total dollar value of all original contract line items less the price for Lump Sum Temporary Traffic Control (LSTTC). If the contract includes multiple projects, this determination will be made for each project. Partial payments will be made as follows:

- (a) The first payment will be made when five percent of the original contract amount is earned. The payment will be 50 percent of the price for LSTTC, or five percent of the original contract amount, whichever is less.
- (b) The second payment will be made when 50 percent of the original contract amount is earned. The payment will be 25 percent of the price for LSTTC, or 2.5 percent of the original contract amount, whichever is less.
- (c) The third payment will be made when 75 percent of the original contract amount is earned. The payment will be 20 percent of the price for LSTTC, or two percent of the original contract amount, whichever is less.
- (d) Payment for the remaining balance due for LSTTC will be made when the contract has been accepted for maintenance or earlier as approved by the engineer.

616.12.1.2 Temporary traffic control will be paid for at the contract lump sum price for Item:

Item No.	Unit	Description
616-99.01	Lump Sum	Misc. Lump Sum Temporary Traffic Control

D. Plans and Specifications

1.0 Description. The following Special Provisions supplement the current version of the "Missouri Standard Specifications for Highway Construction," the current version of the "St. Louis County Department of Highways & Traffic Standard Specifications for Highway Construction," the current version of the "Manual on Uniform Traffic Control Devices for Streets and Highways," in effect on the date of the invitation for bids and the "Proposed Accessibility Guidelines for Pedestrian Facilities in the Public Right-of-Way" published in the Federal Register on July 26, 2011. All work on this project shall be performed in accordance with the current version of the Missouri Standard Specifications for Highway Construction and shall have precedence except where identified otherwise in the Contract Documents. All items designated with St. Louis County Department of Transportation pay items shall follow the St. Louis County Standard Specifications and Metropolitan St. Louis Sewer District Specifications, when applicable. Applicable editions of the specifications are as follows:

2024 Missouri Standard Specifications for Highway Construction – May 2024

2024 Missouri Standard Plans for Highway Construction - July 2024

St. Louis County Standard Specifications for Road and Bridge Construction – September 2023

St. Louis County Standard Drawings – September 2023

Metropolitan St. Louis Sewer District Specifications – 2023

Manual on Uniform Traffic Control Devices for Streets and Highways, 11th Edition – December 2023

Accessibility Guidelines for Pedestrian Facilities in the Public Right-of-Way – August 2023

E. Project Contact for Contractor/Bidder Questions

1.0 All questions concerning this project during the bidding process shall be forwarded to the project contact listed below.

Collin Wilcox, P.E.
Project Engineer
Lochmueller Group, Inc.
411 N. 10th Street
St. Louis, MO 63101
cwilcox@lochgroup.com
(314)446-5411

F. LPA Buy America Requirements

106.9 Buy America Requirement. On all federal-aid projects, the contractor's attention is directed to Title 23 CFR 635.410 Buy America Requirements and the Bipartisan Infrastructure Law (2021) Build America, Buy America Act Publication L. No. 117-58 regarding Buy America provisions on the procurement of foreign products and materials. Where steel or iron products or construction materials consisting primarily of non-ferrous metals, plastic and polymer-based products, glass, lumber or drywall are to be permanently incorporated into the contract work, these material shall be manufactured in the USA except for "minor usage" as described herein. Furthermore, any coating process of the steel or iron shall be performed in the USA. The use of pig iron and processed, pelletized and reduced iron ore manufactured outside of the USA will be permitted in the domestic manufacturing process for steel or iron material.

106.9.1 Any sources other than the USA as defined will be considered foreign. The required domestic manufacturing process shall include formation of ingots and any subsequent process. Coatings shall include any surface finish that protects or adds value to the product.

106.9.2 "Minor usage" of the above products or coating processes will be permitted, provided the cost of such products does not exceed 1/10 of one percent of the total contract cost or \$2,500.00, whichever is greater. If foreign steel, iron, or coating processes are used, invoices to document the cost of the foreign portion, as delivered to the project, shall be provided and the engineer's written approval obtained prior to placing the material in any work.

106.9.3 Buy America requirements include a step certification for all fabrication processes of all mentioned materials that are accepted per Sec 1000.

106.9.3.1 Items designated as Category 1 will consist of steel girders, piling, and reinforcing steel installed on site. Category 1 items require supporting documentation prior to incorporation into the project showing all steps of manufacturing, including coating, as being completed in the United States and in accordance with CFR Title 23 Section 635.410 Buy America Requirements. This

includes the Mill Test Report from the original producing steel mill and certifications documenting the manufacturing process for all subsequent fabrication, including coatings. The certification shall include language that certifies the following. That all steel and iron materials permanently incorporated in this project was procured and processed domestically and all manufacturing processes, including coating, as being completed in the United States and in accordance with CFR Title 23 Section 635.410.

106.9.3.2 Items designated as Category 2 will include all other steel or iron products not in Category 1 and the construction materials under this requirement which are permanently incorporated in the project. Category 2 items shall consist of, but not be limited to items such as fencing, guardrail, signing, lighting and signal supports. The prime contractor is required to submit a material of origin form certification prior to incorporation into the project from the fabricator for each item that the product is domestic. The Certificate of Materials Origin form ([link to certificate form](#)) from the fabricator must show all steps of manufacturing, including coating, as being completed in the United States and in accordance with CFR Title 23 Section 635.410 Buy America Requirements and be signed by a fabricator representative. The Engineer reserves the right to request additional information and documentation to verify that all Buy America requirements have been satisfied. These documents shall be submitted upon request by the Engineer and retained for a period of 3 years after the last reimbursement of the material.

106.9.3.3 Any minor miscellaneous construction material, steel or iron items that are not included in the materials specifications shall be certified by the prime contractor as being procured domestically. Examples of these items would be bolts for sign posts, anchorage inserts, etc. The certification shall read "I certify all materials permanently incorporated in this project covered under this provision have been to the best of my knowledge procured and all manufactured domestically." The certification shall be signed by an authorized representative of the prime contractor.

106.9.3.4 The National Transportation Product Evaluation Program (NTPEP) compliance program verifies that some non-iron and steel products fabrication processes conform to 23 CFR 635.410 Buy America Requirements and an acceptable standard per 23 CFR 635.410(d). NTPEP compliant suppliers will not be required to submit step certification documentation with the shipment for some selected non-iron and steel materials. The NTPEP compliant supplier shall maintain the step certification documentation on file and shall provide this documentation to the engineer upon request.

106.9.4 When permitted in the contract, alternate bids may be submitted for foreign steel and iron products. The award of the contract when alternate bids are permitted will be based on the lowest total bid of the contract based on furnishing domestic steel or iron products or 125 percent of the lowest total bid based on furnishing foreign steel or iron products. If foreign steel or iron products are awarded the contract, domestic steel or iron products may be used; however, payment will be at the contract unit price for foreign steel or iron products.

106.9.5 Basis of Payment. Any costs incurred by the contractor by reason of compliance with the above requirements shall be considered as included in and completely covered by the unit price bid for the various items of work included in the contract.

G. Emergency Provisions and Incident Management

1.0 The contractor shall have communication equipment on the construction site or immediate access to other communication systems to request assistance from law enforcement or other emergency agencies for incident management. In case of traffic accidents or the need for law enforcement to direct or restore traffic flow through the job site, the contractor shall notify law

enforcement or other emergency agencies immediately as needed. The area engineer's office shall also be notified when the contractor requests emergency assistance.

2.0 In addition to the 911 emergency telephone number for ambulance, fire or law enforcement services, the following agencies may also be notified for accident or emergency situation within the project limits.

Missouri Highway Patrol (573-751-3313)
City of Florissant
Fire: 314-837-4894
Police: 314-831-7000

2.1 This list is not all inclusive. Notification of the need for a wrecker or tow truck services will remain the responsibility of the appropriate law enforcement agency.

2.2 The contractor shall notify law enforcement and emergency agencies before the start of construction to request their cooperation and to provide coordination of services when emergencies arise during the construction at the project site. When the contractor completes this notification with law enforcement and emergency agencies, a report shall be furnished to the engineer on the status of incident management.

3.0 Basis of Payment. No direct pay will be made to the contractor to recover the cost of the communication equipment, labor, materials, or time required to fulfill the above provisions.

H. Utilities

1.0 Existing Utilities. For informational purposes only, the following is a list of names, addresses, and telephone numbers of the known utility companies in the area of the construction work for this improvement:

Utility Name	Known Required Adjustment
Ameren Missouri St. Louis, MO. 63103 314-554-2951	See detailed description below
Spire 3950 Forest Park St. Louis, MO 63108 314-575-8423	See detailed description below
AT&T Missouri 12930 Olive Boulevard Creve Coeur, MO 63141 Terry Rodgers 636-949-1330	See detailed description below
Missouri-American Water Co. 535 New Ballas Road St. Louis, MO 63141 314-991-3404	See detailed description below

<p style="text-align: center;">Charter Communications 941 Charter Commons Town & Country, MO 63017 Chris Shelton 314.386.1649</p>	<p style="text-align: center;">See detailed description below</p>
<p style="text-align: center;">Metropolitan St. Louis Sewer District (MSD) 2350 Market Street St. Louis, MO 63103 314-768-6260 Engineering Division</p>	<p style="text-align: center;">See detailed description below</p>

1.1 Detailed description of required adjustments.

1.1.1 Ameren has overhead single phase facilities on poles located along the north side of rue St. Denis Street and the east side of North Jefferson St along the entire projects. Ameren has prepared a relocation plan that relocates or removes poles that are in conflict with the proposed work.

1.1.2 Charter has underground facilities along rue St. Denis Street from rue St. Ferdinand Street to an Ameren pole at STA 13+36.50, which is to be relocated. There is also a pullbox at STA 13+28.89 that will need to be relocated.

1.1.3 AT&T-d has aerial cables along the north side rue St. Denis Street that are connected to existing Ameren poles. These cables will need to be relocated with the relocated Ameren poles.

1.1.4 MCI – Verizon has buried fiber cable along the east side of North Jefferson Street, which was installed in late 2021. There is a pullbox that will need to be relocated or adjusted to grade at STA 1+30.15 of North Jefferson Street (South) and one that will need to be relocated at STA 4+42.00 of North Jefferson Street (North).

1.1.5 Missouri American Water Company (MAWC) has water main facilities on the north side of the project. Which includes several fire hydrants needing relocation, as shown on the contract plans. There are also several valves and meters to be adjusted or relocated. MAWC has awarded the construction contract for relocation of their facilities, with construction anticipated to begin in early spring 2024.

1.1.6 MSD There is extensive storm sewer work on this project that is within the jurisdiction of MSD. This work is included in the road contract and referenced as project number 22MSD-00498.

1.1.7 Spire have existing buried facilities on the south side of rue St. Denis Street until east of rue St. Jean Street, where the gas facilities are primarily on the north side of rue St. Denis Street, as shown on the contract plans. There are also buried Spire facilities on the east side of rue St. Jean Street and North Jefferson Street. Spire has completed their relocation plans and anticipates performing the relocation prior to the roadway contractor beginning work.

1.2 The existence and approximate location of utility facilities known to exist, as shown on the plans, are based upon the best information available at this time. This information is provided "as-is" and the City expressly disclaims any representation or warranty as to the completeness, accuracy, or suitability of the information for any use. Reliance upon this information is done at the risk and peril of the user, and the City shall not be liable for any damages that may arise from

any error in the information. It is, therefore, the responsibility of the contractor to verify the above listing information indicating existence, location and status of any facility. Such verification includes direct contact with the listed utilities.

1.3 The contractor agrees that any effects of the presence of the utilities, their relocation, contractor's coordination of work with the utilities and any delay in utility relocation shall not be compensable as a suspension of work, extra work, a change in the work, as a differing site condition or otherwise including but, without limitation, delay, impact, incidental or consequential damages. The contractor's sole remedy for the effects of the presence of utilities, delay in their relocation or any other effects shall be an excusable delay as provided in Section 105.7.3. The contractor waives, for itself, its subcontractors, and suppliers the compensability of the presence of utilities, delay in their relocation and any cost to the contractor, its subcontractors and suppliers in any claim or action arising out of or in relation to the work under the contract.

1.4 The contractor shall be solely responsible and liable for incidental and consequential damage to any utility facilities or interruption of the service caused by it or its subcontractors operation. The contractor shall hold and save harmless the City from damages to any utility facilities interruption of service by it or its subcontractor's operation.

1.5 It shall be noted by the contractor that MoDOT is a member of Missouri One Call (800 Dig Rite). Some work on this project may be in the vicinity of MoDOT utility facilities, which includes but is not limited to traffic signal cables, highway lighting circuits, ITS cables, cathodic protection cables, etc. Prior to beginning work, the contractor shall request locates from Missouri One Call. The contractor shall also complete the Notice of Intent to Perform Work form located at the Missouri Department of Transportation website:

<https://www.modot.org/notice-intent>

The contractor shall submit the form over the web (preferred method) or by fax to the numbers on the printed form. The notice must be submitted a minimum of 2 and a maximum of 10 working days prior to excavation just as Missouri One Call requires.

2.0 Utility Relocation Work. There are several utility valves, meters, manhole lids, signal/lighting pull boxes that need to be adjusted in this contract by the road contractor. Bid items are detailed in the quantity sheet table in the contract plans and the table is labeled "ADJUST TO GRADE".

3.0 Utility Permits. The Contractor is responsible for obtaining the MSD Permit for this job. Any fees necessary for the permit will be the Contractor's responsibility to pay. A copy of the MSD Permit shall be given to the Engineer.

I. Americans With Disabilities Act (ADA) Compliance And Final Acceptance Of Constructed Facilities

1.0 Description. The contractor shall comply with all laws pertaining to the Americans with Disabilities Act (ADA) during construction of pedestrian facilities on public rights of way for this project. An ADA Checklist is provided herein to be utilized by the contractor for verifying compliance with the ADA law. The contractor is expected to familiarize himself with the plans involving pedestrian facilities and the ADA Post Construction Checklist prior to performing the work.

2.0 ADA Checklist. The contractor can locate the ADA Checklist form on the Missouri Department of Transportation website:

<https://www.modot.org/forms-contractor-use>

2.1 The ADA Checklist is not to be considered all-inclusive, nor does it supersede any other contract requirements. The ADA checklist is a required guide for the contractor to use during the construction of the pedestrian facilities and a basis for the City of Florissant's acceptance of work. Prior to work being performed, the contractor shall bring to the engineer's attention any planned work that is in conflict with the design or with the requirement shown in the checklist. This notification shall be made in writing. Situations may arise where the checklist may not fully address all requirements needed to construct a facility to the full requirements of current ADA law. In those situations, the contractor shall propose a solution to the engineer that is compliant with current ADA law using the following hierarchy of resources: Accessibility Guidelines for Pedestrian Facilities in the Public Right-of-Way – August 2023, 2010 ADA Standards for Accessible Design, MoDOT's Engineering Policy Guidelines (EPG), or a solution approved by the U.S. Access Board.

2.2 It is encouraged that the contractor monitor the completed sections of the newly constructed pedestrian facilities in attempts to minimize negative impacts that his equipment, subcontractors or general public may have on the work. Completed facilities must comply with the requirements of ADA and the ADA Checklist or have documented reasons for the non-complaint items to remain.

3.0 Coordination of Construction.

3.1 Prior to construction and/or closure on an existing pedestrian path of travel, the contractor shall submit a schedule of work to be constructed, which includes location of work performed, the duration of time the contractor expects to impact the facility and an accessible signed pedestrian detour complaint with MUTCD Section 6D that will be used during each stage of construction. This plan shall be submitted to the engineer for review and approval at or prior to the pre-construction conference. Accessible signed detours shall be in place prior to any work being performed that has the effect of closing an existing pedestrian travel way.

3.2 When consultant survey is included in the contract, the contractor shall use their survey crews to verify that the intended design can be constructed to the full requirements as established in the 2010 ADA Standards. When 2010 ADA Standards do not give sufficient information to construct the contract work, the contractor shall refer to the PROWAG.

3.3 When consultant survey is not included in the contract, the contractor shall coordinate with the engineer, prior to construction, to determine if additional survey will be required to confirm the designs constructability.

4.0 Final Acceptance of Work. The contractor shall provide the completed ADA Checklist to the engineer at the semi-final inspection. ADA improvements require final inspection and compliance with the ADA requirements and the ADA Checklist. Each item listed in the checklist must receive either a "YES" or an "N/A" score. Any item receiving a "NO" will be deemed non-compliant and shall be corrected at the contractor's expense unless deemed otherwise by the engineer. Documentation must be provided about the location of any non-complaint items that are allowed to remain at the end of the construction project. Specific details of the non-complaint items, the ADA requirement that the work was not able to comply with, and the specific reasons that justify the exception are to be included with the completed ADA Checklist provided to the engineer.

4.1 Slope and grade measurements shall be made using a properly calibrated, 2 foot long, electronic digital level approved by the engineer.

5.0 Basis of Payment. The contractor will receive full pay of the contract unit cost for all sidewalk, ramp, curb ramp, median, island, approach work, cross walk striping, APS buttons, pedestrian heads, detectible warning systems and temporary traffic control measures that are completed during the current estimate period as approved by the engineer. Based upon completion of the ADA Checklist, the contractor shall complete any necessary adjustments to items deemed non-compliant as directed by the engineer.

5.1 No direct payment will be made to the contractor to recover the cost of equipment, labor, materials, or time required to fulfill the above provisions, unless specified elsewhere in the contract documents.

J. Safety Requirements

1.0 Description. Delete Sec 616.3.1 and substitute the following:

616.3.1 All workers within highway right of way shall wear approved ANSI/ISEA 107 Performance Class 2 or 3 safety apparel and more specifically as follows:

616.3.1.1 Daytime Flagger. During daytime activities, flaggers shall wear a high visibility hard hat, safety glasses, a Performance Class 3 top OR a Performance Class 2 top, and safety footwear. Hard hats other than high visibility orange or green shall be covered with a high visibility covering.

616.3.1.2 Daytime Worker. During daytime activities, workers shall wear a hard hat, safety glasses, a Performance Class 3 top OR a Performance Class 2 top, and safety footwear.

616.3.1.3 Nighttime Flagger. During nighttime activities, flaggers shall wear a high visibility/reflective hard hat, safety glasses, a Performance Class 3 top AND Class E bottoms, OR Performance Class 2 top AND Class E bottoms, and safety footwear. Hard hats shall be reflective or covered with a high visibility covering.

616.3.1.4 Nighttime Worker. During nighttime activities, workers shall wear a hard hat, safety glasses, a Performance Class 3 top OR Performance Class 2 top AND Class E bottoms, and safety footwear.

2.0 A graphic representation of the various PPE as described above can be found in the "Additional Information" portion of these provisions. A color representation can be found on the MoDOT website at: <http://tinyurl.com/Safe-Apparel>.

K. Safety Plan

1.0 Description. This contractor shall submit to the engineer a project Safety Plan (SP) for all work performed by the contractor and all subcontractors. The purpose of the SP is to encourage and enable all work to be performed in the safest possible manner and that all parties involved are aware of their individual responsibility for safety on the jobsite.

1.1 The SP shall be completed by the contractor and provided to the engineer prior to the

beginning of any construction activity or phase on the project.

1.2 The contractor shall designate a person to serve as Project Safety Manager (PSM). The PSM shall be responsible for implementing and overseeing the SP. The PSM is not required to be present on the project at all times but must be available to address safety issues and needs.

1.3 The PSM shall make revisions to the SP as necessary. Any new project activities or phases shall be included in the SP prior to work beginning on that activity or phase.

1.4 An example Safety Plan is available at: www.modot.org/safetyplan

1.5 Emergency Preparedness. The SP shall outline and detail for all workers, the specific procedures and actions necessary to respond to a jobsite emergency and the measures taken to communicate these requirements to all workers.

1.6 The SP shall include a list of local emergency contacts including phone numbers. A copy of the emergency contact list shall be accessible to workers.

1.7 In the case where there is no cellular or land line phone service at the jobsite, the SP shall identify how to reach the nearest available phone service.

1.8 Project Safety Analysis. The SP should contain a basic Project Safety Analysis (PSA) that outlines the actions necessary to complete each activity or phase of the project. The SP shall include a general description of the primary activities or steps required to safely complete the project.

1.9 Each activity should also include a general description of the work involved along with the known risks associated with the activity. In addition, the PSA should outline the controls for those risks, including any Personal Protection Equipment (PPE) requirements for that activity or phase, and whether or not the activity or phase requires a specific safety meeting prior to beginning the activity or phase.

1.10 Submittal of the PSA for all activities or phases is not required with the initial submittal of the SP; however, the PSA for each activity or phase shall be completed prior to the beginning of that activity or phase.

2.0 Safety Meetings. The SP shall include the types of safety meetings that will be required of and conducted by the contractor.

2.1 Safety Training. The SP shall identify the required safety training provided to the contractor's personnel. The contractor shall require that the appropriate safety training for the contractor's personnel is completed prior to the beginning of work on each activity or phase.

2.2 The SP shall identify the recommended safety training needs and PPE for MoDOT employees who will be exposed to the work activities. MoDOT will provide safety training and PPE to MoDOT employees based on MoDOT safety policies.

L. Daily Earthwork Duty

1.0 Description. Daily, the contractor shall be responsible for maintaining drainage patterns that avoid the ponding of drainage water.

2.0 Basis of Payment. There will be no direct payment made to the contractor for complying with this provision.

M. Field Verification

1.0 Description. Plan details for this contract work are based upon available plans, marked utilities and field surveys performed in conjunction with plan preparation for this proposed work. No warranty is made on either the accuracy or completeness of these available documents. It is the Contractor's (Bidder's) responsibility to assess the actual field conditions and verify the location of all utilities and verify whichever dimensions are required for the performance of the work.

2.0 Basis of Payment. There will be no direct payment made to the contractor for complying with this provision.

N. Do Not Disturb Items

1.0 Description. The contractor's attention is directed to the fact that there are multiple utility facilities such as manholes, water meters, pull boxes, power poles, light poles, inlets, water valves, gas valves, signs, etc. located in the existing pavement, sidewalks, pavement, grass areas or other areas near the improvements. Care should be taken to avoid damage to the facilities. These items are shown to be used in place (UIP) on the plans.

1.1 Any damage to existing facilities will be the responsibility of the contractor and shall be repaired and paid for by the contractor.

2.0 Basis of Payment. No direct payment will be made to recover the cost of equipment, labor, materials, or time required to fulfill the above provision.

O. Saw Cuts

1.0 Description. Saw cuts will be required for removal of any pavement, driveways, paved approaches, shoulder, median, curb, curb and gutter, sidewalk, curb ramp or other item adjacent to the pavement, shoulder, median, curb, curb and gutter, sidewalk or other item to remain in place or for permanent construction.

1.1 Saw cuts shall be made to the full depth of the item.

1.2 If the sawed edge of portions to remain are damaged during removal or subsequent construction activities, the Engineer may direct the Contractor to make a new saw cut to remove the damaged portion.

2.0 Basis of Payment. All costs for materials, equipment, labor, and installation required for saw cuts shall be included in the cost for REMOVAL OF IMPROVEMENTS and be paid for at the contract lump sum price. The quantities shown in the plans may not be an all-inclusive list of every saw cut required; there may be additional saw cuts required. Regardless if shown on the quantities, no additional compensation will be made to the contractor for any additional saw cuts required.

P. Earthwork

1.0 Description. This work shall include any excavation, and/or embankment construction required to obtain the required subgrade elevations.

2.0 Construction Requirements. The contractor shall provide all excavation and/or fill placement required to modify existing site conditions to the required subgrade elevation to complete the construction to the required lines and grades as shown on the plans. All work shall be in accordance with the construction requirements of Section 203.

3.0 Basis of Payment. All costs for materials, equipment, labor, and installation shall be included in the cost for CLASS A EXCAVATION and be paid for at the contract cubic yard price. No additional compensation will be made to the contractor for any hauling of material to or from the site to complete this work.

Q. Truncated Domes

1.0 Description. This work shall consist of installing truncated dome panels at the locations shown on the plans in accordance with Section 608.

1.1 Panels shall be cast-in-place type with no exposed fasteners.

1.2 Panel color shall be Safety Red.

2.0 Construction Requirements. The contractor shall provide all materials, labor, and equipment required to complete the construction to the required lines and grades as shown on the plans. All work shall be in accordance with the construction requirements of Section 608.

3.0 Basis of Payment. All costs for materials, equipment, labor and installation shall be included in the cost for "Truncated Domes" and be paid for at the contract square foot price. No additional compensation will be made to the contractor for any cutting of panels or waste resulting from cutting panels to fit.

R. Decorative Pavers

1.0 Description. This work shall consist of installing brick paver sidewalk at the locations shown on the plans in accordance with Section 608 and as modified herein.

1.1 Brick paver sidewalk shall be constructed utilizing clay brick designed for use as a paver. Wall bricks will not be allowed.

1.2 Pavers may be reclaimed historic clay brick or new manufactured units generally red in color with some color variation.

1.3 The Contractor shall submit at least three (3) options of paver to the Engineer for selection of the final product to be used.

1.4 Pavers shall be laid in a herringbone pattern. When the brick paver installation is not bordered by curb, sidewalk, pavement, etc. an edge restraint designed for the application shall be installed in accordance with the manufacturer's recommendations.

1.5 Installation shall follow industry standards and the contractor shall provide evidence of prior experience installing brick pavers.

2.0 Construction Requirements. The contractor shall provide all materials, labor, and equipment required to complete the construction to the required lines and grades as shown on the plans. All work shall be in accordance with the construction requirements of the applicable sections of the standard specifications unless modified herein.

2.1 Aesthetic Mockup, Review, and Approval. A one (1) square yard full-scale mock-up using actual job specific edge restraint (if other than combination concrete curb and gutter), materials, brick dimension, colors, methods, and workmanship shall be provided by the Contractor. The actual vibrating equipment and vibrating rate to be used on the job shall be used on the mockup. The accepted mock-up will be the standard by which remaining work will be evaluated for technical and aesthetic merit. The mock-up may be in a location of proposed installation where it may remain if approved by the Engineer.

2.2 Preparation of Base. The aggregate base shall be prepared according to Section 304 of the Standard Specifications.

2.3 Edge Restraints. Edge restraints shall be placed to a depth of at least the bottom of the bedding course. For pavement, a transverse full-depth cast-in-place concrete header shall be placed at the limits of the pavement.

2.4 Bedding Course. The fine aggregate for bedding shall be placed and screeded, without compaction, to a uniform thickness of 1 to 1.5 in. (25 to 38 mm). Prepared areas shall not be left overnight unless they are protected from disturbance and moisture. Stockpiled material shall be kept covered. Any saturated bedding aggregate shall be removed and replaced.

2.5 Installation. The bricks or pavers shall be laid in the pattern shown on the plans with a joint width from 1/8 to 1/4 in. (3 to 6 mm) on all sides. Whole bricks or pavers shall be laid first, starting from an exact edge or from the centerline of the pavement, followed by cut bricks or pavers. Cut bricks or pavers shall be at least 33 percent of the whole unit size. After the entire pavement or sidewalk has been laid, it shall be set into the bedding course by one pass of the vibrator/compactor. Vibration/compaction shall stop within 3 ft (1 m) of any unrestrained edge. For pavement, construction equipment shall not be driven on the new surface until the joints have been filled.

2.6 Joint Filling. The fine aggregate for joint filling shall be spread over the pavement or sidewalk and hand broomed into the joints. The aggregate shall then be worked down into the joints with multiple passes of the vibrator/compactor. Each pass shall be alternated 90 degrees from the previous pass. This process shall be repeated until the joints are completely filled. Excess fine aggregate shall be removed by hand brooming. All bricks and pavers within 6 ft (1.8 m) of the laying face shall be compacted and the joints completely filled with sand at the end of each workday. For pavement, final rolling shall be completed with a 5 – 10 ton (4.5 – 9 metric ton) static pneumatic-tired roller.

2.7 Smoothness. For pavement, the completed surface will be tested for smoothness with a 16 ft (5 m) straightedge. Surface variations of the mainline pavement shall not exceed 3/16 in. (5 mm).

3.0 Basis of Payment. All costs for materials, equipment, labor and installation including bedding and joint filling material shall be included in the cost for DECORATIVE PAVERS and be paid for at the contract square yard price.

S. Modular Block Wall (H<4')

1.0 Description. This work shall consist of constructing small block walls at the locations shown on the plans in accordance with Section 703.

1.1 Walls adjacent to existing “modular block” type walls shall be constructed with units of similar style and color to the existing wall.

1.2 Walls at other locations shall be constructed of units that provide a natural stone look. The Contractor shall submit at least three (3) options of block style with various color options to the Engineer for selection of the final product to be used.

2.0 Construction Requirements. The contractor shall provide all excavation and/or fill placement required to modify existing site conditions to the required subgrade elevation to complete the construction to the required lines and grades as shown on the plans and as required by the wall unit manufacturer’s recommendations. All work shall be in accordance with the construction requirements of Section 703 and the wall unit manufacturer’s installation recommendations.

3.0 Basis of Payment. All costs for materials, equipment, labor, and installation shall be included in the cost for MODULAR BLOCK WALL (H<4') at the contract square foot price.

T. Adjust To Grade Items

1.0 Description. This work shall consist of adjusting water valves, water meters, water vaults, basins/inlets, manholes, landscaping lights, and pull boxes that are within areas where either new sidewalks/ramps/approaches/pavement are to be constructed as shown on the plans. The adjustments shall be made to match the final proposed grade.

2.0 Construction Requirements. Adjustments, extensions, and/or lowering of utility and any related excavation and backfill shall be constructed as approved by the Engineer. For MoDOT owned facilities, adjustments shall conform to current Missouri Standard Specifications for Highway Construction. For MSD owned facilities, adjustments shall conform to current MSD Standards and Specifications. Adjustments shall be completed to ensure the finished sidewalk, ramp, approach, or pavement will meet current ADA standards.

3.0 Basis of Payment. All costs for materials, equipment, labor, and installation shall be included in the cost for adjusting the water valves, water meters, basins/inlets, manholes, and pull boxes. No direct payment will be made for any required hauling, cutting, joining, backfilling, or adjusting rings, or any other requirements necessary to fulfill this provision. No direct payment will be made to recover the cost of equipment, labor, materials, or time required to fulfill the above provision.

U. Hydrodynamic Separator (6')

1.0 Description. This work shall consist of installation of a hydrodynamic separator system meeting MSD requirements and approved by MSD for off-line use at the location shown on the plans.

2.0 Construction Requirements. The installation shall be completed in accordance with MSD requirements and shall follow the manufacturer’s recommendations. The contractor shall submit shop drawings and associated calculations for the proposed system to the engineer for review.

3.0 Basis of Payment. All costs for materials, equipment, labor, and installation of the separator structure and piping to connect it to the storm sewer system shall be paid for at the contract unit price for bid item HYDRODYNAMIC SEPARATOR (6’), per each.

V. Reinforcing Fibers for Bituminous Pavement Material

1.0 Description. This work shall consist of adding a high tensile strength synthetic fiber to the bituminous mixture to be placed as specified in the contract documents. The Fiber Reinforced Asphalt Concrete (FRAC) mixture produced shall meet all Sec 403 requirements. The material properties, handling, mixing and placement of the fibers shall be in accordance with this provision.

2.0 Materials.

2.1 Fiber Properties. The reinforcing fibers shall contain aramid fibers and a dispersion aid that meet the following material requirements as detailed in Table 1 below:

Table 1 – Aramid Reinforcing Fibers Material Properties		
Property	Test Method	Criteria
Form	Manufacturer Certification	Aramid Fibers
Length (in)	Manufacturer Certification	0.75
Melting Temperature	Manufacturer Certification	800 F
Nominal Specific Gravity (g/cm ³)	ASTM D276	1.44
Tensile Strength ¹ (psi)	ASTM D7269	400,000

2.2 Performance Testing. A FRAC mixture shall meet the following performance test detailed in Table 2 below. Non-aramid fiber blends will not be considered alternatives to this specification. All performance testing results from previous laboratory trial FRAC mixtures shall be submitted to the engineer along with the job mix formula.

Table 2 – FRAC Mixture Performance Requirements			
Performance Measure	Test Method	Standard	Requirement
Dispersion Efficiency, %	Aramid Dispersion State Ratio (ADSR)	Modified ASTM D2172	≥ 85 %
Cracking Resistance, % increase	Indirect Tensile Strength (IDT)	AASHTO T 322 or ASTM D6931	≥ 20 % increase
Resistance to Permanent Deformation (Rutting)	Flow Number	AASHTO TP 79	≥ 35 % increase
	Hamburg	AASHTO T 324	< 3 mm

Performance testing shall be from previous completed laboratory trials performed on plant mixed FRAC. Testing is not required on samples from the job mix. Performance testing shall be from

laboratory trials at a fiber dosage rate equal to the rate proposed for the project. Tests must be performed by an AASHTO accredited testing lab and must be reviewed and approved by the engineer.

Aramid Dispersion State Ratio (ADSR) tests shall be conducted from a minimum of three separate laboratory FRAC trials in accordance with the following:

1. Perform ADSR test in accordance with Modified ASTM D2172 (test method documentation available in the Electronic Deliverables).
2. The average extracted aramid fiber quantity shall equal 0.007 percent by total sample weight with no individual result less than 0.005 percent of the total sample weight.
3. All tested fiber mixes shall achieve a minimum ADSR of 85%.

Indirect Tensile (IDT) Strength Tests shall be conducted from a minimum of three (3) separate laboratory trials in accordance with the following:

1. Perform indirect tensile tests using the protocol from AASHTO T322 or ASTM D6931.
2. Tests results shall include a control and a fiber reinforced mix. FRAC mix shall be identical to control mix except for the inclusion of fibers added at the same dosage as proposed on the project.
3. Indirect tensile test results from fiber specimens shall show an average tensile strength increase of 30 percent over control specimen with no samples having less than 25 percent increase of average tensile strength.

Resistance to Permanent Deformation (Rutting) shall be measured on the FRAC mixture by one of the following test methods: Flow Number Test or Hamburg.

Flow Number (FN) testing shall be performed on a minimum of three (3) separate laboratory trials in accordance with the following:

1. Perform flow number testing in accordance with AASHTO TP79.
2. Test results shall include a control mixture and a FRAC mixture. The FRAC mixture shall be identical to the control mix except for the inclusion of fibers added at the same dosage rate as proposed on the project.
3. Results from the FRAC specimens shall each show an average FN increase of at least 35 percent over the control specimens.

Hamburg testing shall be performed on a minimum of three (3) separate laboratory trials in accordance with the following:

1. Perform Hamburg testing in accordance with AASHTO T324.
2. Test results may include only the FRAC mixture at the same dosage rate as proposed on the project.
3. Results from the FRAC specimens shall show less than 3 mm of rutting.

2.3 Required Information. The contractor shall furnish a manufacturer's certification to the engineer for each lot of material furnished stating the name of the manufacturer, the chemical composition, and certifying that the material supplied is in accordance with this specification.

3.0 Construction.

3.1 Delivery, Storage, and Handling. The fiber-reinforcement material shall be delivered, stored, and handled in accordance with the manufacturer's recommendations and specifically as follows:

1. Deliver fiber-reinforcement in sealed, undamaged containers with labels intact and legible, indicating material name and lot number.
2. Deliver fiber-reinforcement to location where it shall be added to each batch or loaded into the mixer.
3. Store materials covered and off the ground. Keep sand and dust out of boxes and do not allow boxes to become wet.

3.2 Mixing and Production. The system for adding fibers to the mix shall be approved by the fiber manufacturer. The engineer shall be informed in writing that the system being used to add the fibers in the asphalt mixture meets the fiber manufacturer's recommendations.

The fiber reinforcement shall be added at the dosage rate that meets the FRAC Mixture Performance Requirements listed in Table 2 as prescribed by the manufacturer. A fiber manufacturer shall be on site during the mixing and production of FRAC material.

The following construction steps shall be used when producing the FRAC or as required by the manufacturer.

Batch Plant: When a batch plant is used, add fiber to the aggregate in the weigh hopper and increase both dry and wet mixing times. Ensure that the fiber is uniformly distributed before the injection of asphalt cement into the mixture.

Drum Plant: For drum plants, inject fibers through the reclaimed asphalt pavement (RAP) collar using an automatic, metered air blown system to promote rapid and complete fiber dispersion. System must automatically record fiber addition data so as to remove human error. Rate the feeding of fibers with the rate the plant is producing asphalt mix. If there is any evidence of fiber bundles at the discharge chute, increase the mixing time and/or temperature or change the angle of the fiber feeder line to increase dry mixing time.

For small quantity projects less than 2000 tons, manual feeding of the fibers may be allowed in accordance with the manufacturer's recommendations. For projects greater than 2000 tons, manual feeding of the fibers is not allowed.

For blower tube system, add fibers continuously and in a steady uniform manner. Provide automated proportioning devices and control delivery within $\pm 10\%$ of the mass of the fibers required. Perform an equipment calibration to the satisfaction of the fiber manufacturer's representative to show that the fiber is being accurately metered and uniformly distributed into the mix.

Include the following for blower tube system:

1. Low level indicators
2. No-flow indicators
3. A printout of feed rate status in pounds/ minute
4. A section of transparent pipe in the fiber supply line for observing consistency of flow or feed.

3.3 Quality Control. A minimum of 25 pounds FRAC sample shall be collected during the first 50 tons of production. The sample shall be visually inspected to determine the uniform dispersion of the aramid fibers in an individual state (no bundles or agitated bundles). If undistributed bundles exist, the plant shall adjust the mixing operations until the aramid fibers are in and individual state.

3.4 Placement. In addition to the visual inspection the FRAC mix shall be visually observed in the back of first three trucks and every tenth truck thereafter to confirm the adequate blending of the fibers.

4.0 Basis of Payment. Payment for the high tensile strength synthetic fibers shall be paid for at the contract unit price per ton for Item Number 403-99.10 MISC. HIGH TENSILE STRENGTH SYNTHETIC FIBER ASPHALTIC CONCRETE MIXTURE SP125CLP MIX/SP095CLP MIX.

W. Vibratory Activities

1.0 Description. There are two properties along the project limits that are listed in the National Historic Register of Historic Places, Casa Alvarez (289 Rue St. Denis Street) and the Archambault House (603 Rue St. Denis Street). The contractor is hereby notified that vibratory rollers and jackhammers for roadway construction will be prohibited within 100 feet of any part of these structures due to sensitive historic resources. The contractor shall sawcut and excavate for any removals required within these limits.

X. Install Lighting Equipment

1.0 Description. Where indicated in the plans, the Contractor shall install new pedestrian-scale lighting equipment.

2.0 New pedestrian poles and luminaires, and other miscellaneous hardware shall be provided per the details including in the plans. The luminaire shall be 4000K in light temperature. Lighting models for the corridor were based on Sternberg Lighting Model - 8930 Classic Fixture, CLU 048 with LEDiL Optic, Type 3, Clear Seeded Acrylic. Any alternate luminaires shall meet the performance of the modelled luminaire, and are subject to approval by the Engineer. Shop drawings for all proposed lighting poles and luminaires shall be provided to the Engineer for approval prior to procurement.

2.1 Lighting pullboxes and concrete foundations shall be made flush with the adjacent sidewalk pavement. Grinding of pullbox and foundation tops or edges is not an acceptable method for meeting this requirement.

2.2 Work and materials shall conform to the rules of the National Board of Fire Underwriters' Code and the Regulations of the State Fire Marshal. Nothing in these specifications shall be construed to permit work not conforming to the most stringent of applicable codes. The currently adopted version of the National Electric Code (NEC), is the local electric code, and the electrical requirements as established by the State and Local Fire Marshal, and rules and regulations of the power company serving the project, are hereby made part of this specification. Should any changes be necessary in the drawings or specifications to make the work comply with these requirements, the Contractor shall notify the Engineer.

2.3 The entire electrical system and all electrical equipment shall be grounded in strict accordance with the currently adopted edition of the National Electrical Code. After installing grounding system but before permanent electrical circuits have been energized, test for compliance with requirements. Inspect physical and mechanical condition. Verify tightness of accessible, bolted, electrical connections with a calibrated torque wrench according to manufacturer's written instructions. Test completed grounding system at each location where a maximum ground resistance level is specified, at service disconnect enclosure grounding terminal, and at individual ground rods and as directed by the Engineer. Make tests at ground rods before any conductors are connected. Measure ground resistance no fewer than two full

days after last trace of precipitation and without soil being moistened by any means other than natural drainage or seepage and without chemical treatment or other artificial means of reducing natural ground resistance. Perform tests by fall-of-potential method according to IEEE 81. If resistance to ground exceeds specified values, notify the Engineer promptly and include recommendations to reduce ground resistance.

2.4 Conductors shall be color-coded either by insulation at the manufacturer, or by means of conductor tape at each pullbox, pole base, or terminal block.

2.5 Splices shall be compatible with conductor material and possess equivalent or better mechanical strength and insulation ratings than unspliced conductors. All splice kits shall be waterproof.

2.6 For each conductor entering a pullbox, light pole, or other accessible locations, at least 12 inches of slack shall be stored.

2.7 Install conduit sealing compound to all open conduit ends.

2.8 Lighting pullboxes shall have a nonskid finish, and include cover labels stating "Street Lighting".

2.9 Conduit shown in the plans and quantities as trenched may be installed via pushed methods, but will be paid for at the trenched bid price. All conduit, conductor, and pullbox materials shall be listed on the current MoDOT approved product list for lighting materials.

3.0 The contractor shall submit product warranty documents to the engineer prior to acceptance of the work.

4.0 Basis of Payment. This work shall include all labor, equipment, and transportation of materials as part of pay items LIGHTING POLE, 12 FT; LIGHTING POLE FOUNDATION, TYPE C; LUMINAIRE, POST TOP, TENON MOUNT; PULL BOX PREFORMED CLASS 1, per each; and CONDUIT, 2IN. RIGID, IN TRENCH; CONDUIT, 2IN. RIGID, PUSHED; CABLE, 12 AWG 1 CONDUCTOR, POLE AND BRACKET; and CABLE, 8 AWG, 1 CONDUCTOR, per linear foot.

Y. Pad Mounted Power Supply

1.0 Description. This work shall consist of furnishing and installing 120/240 Volt power supply assembly. The power supply shall be multi-circuit and mounted on a concrete pad as shown in the plans. The Contractor shall submit proposed power supply cabinet and associated internal hardware to the Engineer for approval prior to procurement.

2.0 Basis of Payment. Payment for furnishing and installing pad mounted power supplies shall include all excavation, materials, equipment, tools, labor, and work incidental thereto. Payment will be made as PAD MOUNTED 120V/240V LIGHTING CONTROLLER, per each.

Z. Wrought Iron Fence

1.0 Description. This work shall consist of furnishing and installing 48" height wrought iron fence and concrete footing/foundation at locations shown on the plans.

2.0 Materials. Furnish materials in accordance with the details shown on the plans that include posts, pickets, rails, post caps, and all necessary fittings and appurtenances required for proper installation. Provide the Engineer with the specifications of all items for the fence, for approval, before fabrication and installation. Use only new materials.

3.0 Construction. Before work commences in the area, inform and inspect the site with the Engineer. After the construction is complete, inspect the site again with the Engineer for approval.

Obtain approval from the Engineer before use of all material for the new fence panels. The new fence including but not limited to posts, pickets, rails, and post caps must be installed at locations shown on the plans and as directed.

Black powder-coat the wrought iron fence with a powder coating consisting of an acrylic resin type with no vinyl or styrene modification.

If necessary, reinforce the fence joints with either welding or welded on metal that will not detract from the decorative appeal of the fence. All welding will be performed in a workman-like manner with solid joints of minimum protrusion. The completed fence will be solid and have minimal flexure. Ground off any excessive weld spatter.

4.0 Measurement Wrought iron fence will be measured by the foot of fence installed.

5.0 Basis of Payment. The work performed and the materials furnished, in accordance with this Item and measured as provided under "Measurement," will be paid for at the unit price bid for, "Wrought Iron Fence (48)". This price is full compensation for furnishing; hauling; installing fence and concrete pad materials; and furnishing all labor, tools, equipment, and incidentals.

AA. Ornamental Steel Fence

1.0 Description.

- 1.1** This work shall consist of all necessary earthwork, equipment, materials and labor for the furnishing and installing of Ornamental Steel Fence, including concrete footing/foundation at the locations shown on the plans.
- 1.2** Fencing shall be painted black.
- 1.3** All decorative fencing shall accommodate all loads (lateral loads for example) required by local permitting agencies.
- 1.4** Manufacturer of fencing shall provide a 20-year paint coating warranty to City of Florissant
- 1.5** The contractor shall supply a decorative fence that exhibits the same general characteristics of strength, workmanship and style as those shown on Montage II® - Majestic 3-Rail, 4' Height Fence manufactured by Ameristar Guardrail Products, Inc., in Tulsa, Oklahoma. The system shall include all components such as panels, posts, gates, and hardware required. No spikes on guardrail system.
- 1.6** Submittals: The manufacturer's information shall be submitted prior to installation. Manufacturer's warranty upon substantial completion shall be provided.
- 1.7** Quality Assurance: The contractor shall provide laborers and supervisors who are thoroughly familiar with the type of construction involved and materials and techniques specified.
- 1.8** Product Handling and Storage: Upon receipt at the job site, all materials shall be checked to ensure that no damage occurred during shipping or handling. Materials shall be stored in such a manner to ensure proper ventilation and drainage, and to protect against damage, weather, vandalism and theft.

2.0 Materials.

- 2.1** Steel material for fence panels and posts shall conform to the requirements of ASTM A653/A653M, with a minimum yield strength of 45,000 psi (310 MPa) and a minimum

zinc (hot-dip galvanized) coating weight of 0.90 oz/ft² (276 g/m²), Coating Designation G-90.

- 2.2 Material for pickets shall be 1" square x 14 Ga. tubing. The rails shall be steel channel, 1.75" x 1.75" x .105". Picket holes in the rail shall be spaced 4.715" o.c. Fence posts and gate posts shall meet the minimum size requirements of Table 1.
- 2.3 Concrete shall conform to Section 501 and Section 1000 of the Missouri Standard Specifications for Highway Construction.

3.0 Fabrication.

- 3.1 Pickets, rails and posts shall be pre-cut to specified lengths. Rails shall be pre-punched to accept pickets.
- 3.2 Pickets shall be inserted into the pre-punched holes in the rails and shall be aligned to standard spacing using a specially calibrated alignment fixture. The aligned pickets and rails shall be joined at each picket-to-rail intersection by a fusion welding process, thus completing the rigid panel assembly.
- 3.3 The manufactured panels and posts shall be subjected to an inline electrodeposition coating process consisting of a multi-stage pretreatment/wash, followed by a duplex application of an epoxy primer and an acrylic topcoat. The minimum cumulative coating thickness of epoxy and acrylic shall be 2 mils (0.058 mm). The color shall be Black. The coated panels and posts shall be capable of meeting the performance requirements for each quality characteristic shown in Table 2 (Note: The requirements in Table 2 meet or exceed the coating performance criteria of ASTM F2408).
- 3.4 The manufactured fence system shall be capable of meeting the vertical load, horizontal load, and infill performance requirements for Industrial weight fences under ASTM F2408.

4.0 Execution

- 4.1 **Preparation.** All new installation shall be laid out by the contractor in accordance with the construction plans.
- 4.2 **Fence Installation.** Fence post shall be spaced according to Table 3, plus or minus 1/2". For installations that must be raked to follow sloping grades, the post spacing dimension must be measured along the grade. Fence panels shall be attached to posts with brackets supplied by the manufacturer. Posts shall be set in concrete footers having a minimum depth of 36" (Note: In some cases, local restrictions of freezing weather conditions may require a greater depth). Posts setting by other methods such as plated posts or grouted core-drilled footers are permissible only if shown by engineering analysis to be sufficient in strength for the intended application.
- 4.3 **Fence Installation Maintenance.** When cutting/drilling rails or posts adhere to the following steps to seal the exposed steel surfaces; 1) Remove all metal shavings from cut area. 2) Apply zinc-rich primer to thoroughly cover cut edge and/or drilled hole; let dry. 3) Apply 2 coats of custom finish paint matching fence color. Failure to seal exposed surfaces per steps 1-3 above will negate warranty. Spray cans or paint pens shall be used to prime and finish exposed surfaces; it is recommended that paint pens be used to prevent overspray.
- 4.4 **Cleaning.** The contractor shall clean the jobsite of excess materials; post-hole excavations shall be scattered uniformly away from posts.

Table 1 – Minimum Sizes for Posts	
Fence Posts	Panel Height
2-1/2" x 12 Ga.	Up to & Including 6' Height

Table 2 – Coating Performance Requirements		
Quality Characteristics	ASTM Test Method	Performance Requirements
Adhesion	D3359 – Method B	Adhesion (Retention of Coating) over 90% of test area (Tape and knife test).

Corrosion Resistance	B117, D714 & D1654	Corrosion Resistance over 1,500 hours (Scribed per D1654; failure mode is accumulation of 1/8" coating loss from scribe or medium #8 blisters).
Impact Resistance	D2794	Impact Resistance over 60 inch lb. (Forward impact using 0.625" ball).
Weathering Resistance	D822 D2244, D523 (60° Method)	Weathering Resistance over 1,000 hours (Failure mode is 60% loss of gloss or color variance of more than 3 delta-E color units).

Table 3 – Post Spacing	
Span	8' Nominal (92-5/8" Rail)

5.0 Measurement Ornamental Steel Fence will be measured by the foot of fence installed.

6.0 Basis of Payment. The work performed and the materials furnished, in accordance with this Item and measured as provided under "Measurement," will be paid for at the unit price bid for, "Ornamental Steel Fence (48)". This price is full compensation for furnishing; hauling; installing fence and concrete foundation materials; and furnishing all labor, tools, equipment, and incidentals.

BB. Ornamental Cantilever Gate

1.0 Description.

- 1.1 This work shall consist of all necessary earthwork, equipment, materials and labor for the furnishing and installing of Ornamental Cantilever Gate, including concrete footing/foundation at the locations shown on the plans.
- 1.2 Gates shall be painted black.
- 1.3 Gates shall accommodate all loads (lateral loads for example) required by local permitting agencies.
- 1.4 Manufacturer of fencing shall provide a 20-year paint coating warranty to City of Florissant
- 1.5 The contractor shall supply an ornamental cantilever gate system that exhibits the same general characteristics of strength, workmanship and style as those shown on TransPort Traverse II® Majestic™- Ornamental Cantilever Gate System manufactured by Ameristar Guardrail Products, Inc., in Tulsa, Oklahoma. The system shall include all components such as panels, posts, gates, and hardware required. No spikes on guardrail system.
- 1.6 Submittals: The manufacturer's information shall be submitted prior to installation. Manufacturer's warranty upon substantial completion shall be provided.
- 1.7 Quality Assurance: The contractor shall provide laborers and supervisors who are thoroughly familiar with the type of construction involved and materials and techniques specified.
- 1.8 Product Handling and Storage: Upon receipt at the job site, all materials shall be checked to ensure that no damage occurred during shipping or handling. Materials shall be stored in such a manner to ensure proper ventilation and drainage, and to protect against damage, weather, vandalism and theft.
- 1.9 The contractor shall provide laborers and supervisors who are thoroughly familiar with the type of construction involved and materials and techniques specified.

2.0 References

- ASTM A653/A653M - Standard Specification for Steel Sheet, Zinc-Coated (Galvanized) or Zinc-Iron Alloy Coated (Galvannealed) by the Hot-Dip Process.
- ASTM B117 - Practice for Operating Salt-Spray (Fog) Apparatus.

- ASTM B221 – Aluminum and Aluminum Alloy Extruded Bars, Shapes and Tubes
- ASTM D523 - Test Method for Specular Gloss.
- ASTM D714 - Test Method for Evaluating Degree of Blistering in Paint.
- ASTM D822 - Practice for Conducting Tests on Paint and Related Coatings and Materials using Filtered Open-Flame Carbon-Arc Light and Water Exposure Apparatus.
- ASTM D1654 - Test Method for Evaluation of Painted or Coated Specimens Subjected to Corrosive Environments.
- ASTM D2244 - Test Method for Calculation of Color Differences from Instrumentally Measured Color Coordinates.
- ASTM D2794 - Test Method for Resistance of Organic Coatings to the Effects of Rapid Deformation (Impact).
- ASTM D3359 - Test Method for Measuring Adhesion by Tape Test.

3.0 Materials

- 3.1** The materials used for cantilever gate framing (uprights & diagonal bracing) shall be manufactured from ASTM A653 Steel with yield strength of 34,800 PSI, a tensile strength of 37,700PSI and a standard mill finish. The aluminum extrusions for top and bottom enclosed tracks shall be alloy and temper designation 6005-T5 to meet ASTM B221.
- 3.2** Material for pickets shall be 1" square x 16 ga. steel pickets on gate systems less than 22' openings, gate systems greater than 22' openings shall have 1" square x 1/8" wall aluminum pickets. Picket on center spacing shall not exceed 5". Pickets shall be securely fastened to face of top and bottom enclosed track extrusions.
- 3.3** Material for gate uprights shall be 2 1/2" X 16 ga. and diagonal bracing shall be 2" square x 16 ga. steel. The cross-sectional shape of the enclosed-track shall conform to the manufacturer's design with a single extrusion consisting of a 3.75" x 7" channeled support with integrated 3" x 3" enclosed-track raceway. Gates less than 18-foot openings shall be constructed as a single-track system, gates greater than 20-foot openings shall be constructed as a spliced track system.
- 3.4** Steel material for fence posts and pickets shall be galvanized prior to forming in accordance with the requirements of ASTM A653/A653M, with minimum yield strength of 45,000 psi (310 MPa). The steel shall be hot-dip galvanized to meet the requirements of ASTM A653/A653M with a minimum zinc coating weight of 0.90 oz/ft² (276 g/m²), Coating Designation G-90. Depending on application and gate size, material for gate support posts shall be 4" x 11 Ga., or 6" x 3/16".
- 3.5** Support carriage trolley assemblies, for the gates enclosed bottom track, shall have two mounting options: concrete slab or post mount bracket configuration, and shall support the vertical load of the gate. The gates center of gravity shall be centered on the bottom support carriage trolley assemblies. Installation of the carriage trolley assemblies shall be per manufacturer's installation instructions.
- 3.6** Concrete shall conform to Section 501 and Section 1000 of the Missouri Standard Specifications for Highway Construction.

4.0 Fabrication

- 4.1** Gate frame uprights and diagonal bracing shall be prefabricated and pre-punched to accept frame fasteners. Enclosed track shall be pre-punched to accept gate uprights. Pickets shall be pre-cut to specified length and pre-drilled to accept picket to track fasteners. Posts shall be pre-cut to specified lengths.
- 4.2** Top and bottom enclosed track extrusions shall be mechanically fastened to vertical gate uprights and intermediate supports, as required by assembly instructions. Diagonal bracing shall be mechanically fastened to vertical gate uprights and intermediate supports, as required by assembly instructions. Pickets shall be mechanically fastened to top and bottom enclosed track, as required by assembly instructions.

4.3 The manufactured gate components shall be subjected to a thermal stratification coating process (high-temperature, in-line, multi-stage, and multi-layer) including, as a minimum, a six-stage pretreatment/wash and an electrostatic spray application of a polyester finish. The topcoat shall be a “no-mar” TGIC polyester powder coat finish with a minimum thickness of 2 mils (0.0508mm). The color shall black. The stratification-coated framework shall be capable of meeting the performance requirements for each quality characteristic shown in Table 1.

5.0 Execution

5.1 Preparation. All new installation shall be laid out by the contractor in accordance with the construction plans.

5.2 Gate Installation.

A. Cantilever support posts shall be set in concrete footers having a minimum depth of 48” (Note: In most cases, local soil, code restrictions and inclement weather conditions may require a greater depth). Posts shall be spaced according to gate specific submittal drawings. Optional Safety Kit must be included if the gate is automated.

B. Gate to be installed per manufacturers gate installation instructions (written or video). For Gates that will be automated, the contractor shall be responsible to ensure the gate, and installation, meet ASTM F2200 and UL325 Standards.

5.3 Gate Installation Maintenance. When cutting/drilling posts adhere to the following steps to seal the exposed steel surfaces; 1) Remove all metal shavings from cut area. 2) Apply zinc-rich primer to thoroughly cover cut edge and/or drilled hole; let dry. 3) Apply 2 coats of custom finish paint matching fence color. Failure to seal exposed surfaces per steps 1-3 above will negate warranty. Spray cans or paint pens shall be used to prime and finish exposed surfaces; it is recommended that paint pens be used to prevent overspray.

5.4 Gate Installation. Gate posts shall be spaced according to the manufacturers’ drawings, dependent on clear opening. The manufacturers’ gate drawings shall identify the necessary gate hardware required for the application. Gate hardware shall be provided by the manufacture of the gate and shall be installed per manufacturer’s recommendations.

5.5 Cleaning. The contractor shall clean the jobsite of excess materials; post-hole excavations shall be scattered uniformly away from posts.

Table 1 – Coating Performance Requirements		
Quality Characteristics	ASTM Test Method	Performance Requirements
Adhesion	D3359 – Method B	Adhesion (Retention of Coating) over 90% of test area (Tape and knife test).
Corrosion Resistance	B117, D714 & D1654chart	Corrosion Resistance over 1,000 hours (Scribed per D1654; failure mode is accumulation of 1/8” coating loss from scribe or medium #8 blisters).
Impact Resistance	D2794	Impact Resistance over 60 inch lb. (Forward impact using 0.625” ball).
Weathering Resistance	D822 D2244, D523 (60° Method)	Weathering Resistance over 1,000 hours (Failure mode is 60% loss of gloss or color variance of more than 3 delta-E color units).

7.0 Measurement Ornamental Cantilever Gate will be measured per each gate installed.

8.0 Basis of Payment. The work performed and the materials furnished, in accordance with this Item and measured as provided under “Measurement,” will be paid for at the unit price bid for, “Ornamental Cantilever Gate.” This price is full compensation for furnishing; hauling; installing fence and concrete foundation materials; and furnishing all labor, tools, equipment, and incidentals.

CC. Supplemental Revisions JSP-18-01CC

Compliance with [2 CFR 200.216 – Prohibition on Certain Telecommunications and Video Surveillance Services or Equipment](#).

The Missouri Highways and Transportation Commission shall not enter into a contract (or extend or renew a contract) using federal funds to procure or obtain equipment, services, or systems that uses covered telecommunications equipment or services as substantial or as critical technology as part of any system where the video surveillance and telecommunications equipment was produced by Huawei Technologies Company, ZTE Corporation, Hytera Communications Corporation, Hangzhou Hikvision Digital Technology Company, or Dahua Technology Company (or any subsidiary or affiliate of such entities).

Stormwater Compliance Requirements

1.0 Description. This provision requires the contractor to provide a Water Pollution Control Manager (WPCM) for any project that includes land disturbance on the project site and the total area of land disturbance, both on the project site, and all Off-site support areas, is one (1) acre or more. Regardless of the area of Off-site disturbance, if no land disturbance occurs on the project site, these provisions do not apply. When a WPCM is required, all sections within this provision shall be applicable, including assessment of specified Liquidated Damages for failure to correct Stormwater Deficiencies, as specified herein. This provision is in addition to any other stormwater, environmental, and land disturbance requirements specified elsewhere in the contract.

1.1 Definitions. The project site is defined as all areas designated on the plans, including temporary and permanent easements. The project site is equivalent to the “permitted site”, as defined in MoDOT’s State Operating Permit. An Off-site area is defined as any location off the project site the contractor utilizes for a dedicated project support function, such as, but not limited to, staging area, plant site, borrow area, or waste area.

1.2 Reporting of Off-Site Land Disturbance. If the project includes any planned land disturbance on the project site, prior to the start of work, the contractor shall submit a written report to the engineer that discloses all Off-site support areas where land disturbance is planned, the total acreage of anticipated land disturbance on those sites, and the land disturbance permit number(s). Upon request by the engineer, the contractor shall submit a copy of its land disturbance permit(s) for Off-site locations. Based on the total acreage of land disturbance, both on and Off-site, the engineer shall determine if these Stormwater Compliance Requirements shall apply. The Contractor shall immediately report any changes to the planned area of Off-site land disturbance. The Contractor is responsible for obtaining its own separate land disturbance permit for Off-site areas.

2.0 Water Pollution Control Manager (WPCM). The Contractor shall designate a competent person to serve as the Water Pollution Control Manager (WPCM) for projects meeting the description in Section 1.0. The Contractor shall ensure the WPCM completes all duties listed in Section 2.1.

2.1 Duties of the WPCM:

- (a) Be familiar with the stormwater requirements including the current MoDOT State Operating Permit for construction stormwater discharges/land disturbance activities; MoDOT’s statewide Stormwater Pollution Prevention Plan (SWPPP); the Corps of

Engineers Section 404 Permit, when applicable; the project specific SWPPP, the Project's Erosion & Sediment Control Plan; all applicable special provisions, specifications, and standard drawings; and this provision;

- (b) Successfully complete the MoDOT Stormwater Training Course within the last 4 years. The MoDOT Stormwater Training is a free online course available at MoDOT.org;
- (c) Attend the Pre-Activity Meeting for Grading and Land Disturbance and all subsequent Weekly Meetings in which grading activities are discussed;
- (d) Oversee and ensure all work is performed in accordance with the Project-specific SWPPP and all updates thereto, or as designated by the engineer;
- (e) Review the project site for compliance with the Project SWPPP, as needed, from the start of any grading operations until final stabilization is achieved, and take necessary actions to correct any known deficiencies to prevent pollution of the waters of the state or adjacent property owners prior to the engineer's weekly inspections;
- (f) Review and acknowledge receipt of each MoDOT Inspection Report (Land Disturbance Inspection Record) for the Project within forty eight (48) hours of receiving the report and ensure that all Stormwater Deficiencies noted on the report are corrected as soon as possible, but no later than stated in Section 5.0.

3.0 Pre-Activity Meeting for Grading/Land Disturbance and Required Hold Point. A Pre-Activity meeting for grading/land disturbance shall be held prior to the start of any land disturbance operations. No land disturbance operations shall commence prior to the Pre-Activity meeting except work necessary to install perimeter controls and entrances. Discussion items at the pre-activity meeting shall include a review of the Project SWPPP, the planned order of grading operations, proposed areas of initial disturbance, identification of all necessary BMPs that shall be installed prior to commencement of grading operations, and any issues relating to compliance with the Stormwater requirements that could arise in the course of construction activity at the project.

3.1 Hold Point. Following the pre-activity meeting for grading/land disturbance and subsequent installation of the initial BMPs identified at the pre-activity meeting, a Hold Point shall occur prior to the start of any land disturbance operations to allow the engineer and WPCM the time needed to perform an on-site review of the installation of the BMPs to ensure compliance with the SWPPP is met. Land disturbance operations shall not begin until authorization is given by the engineer.

4.0 Inspection Reports. Weekly and post run-off inspections will be performed by the engineer and each Inspection Report (Land Disturbance Inspection Record) will be entered into a web-based Stormwater Compliance database. The WPCM will be granted access to this database and shall promptly review all reports, including any noted deficiencies, and shall acknowledge receipt of the report as required in Section 2.1 (f.).

5.0 Stormwater Deficiency Corrections. All stormwater deficiencies identified in the Inspection Report shall be corrected by the contractor within 7 days of the inspection date or any extended period granted by the engineer when weather or field conditions prohibit the corrective work. If the contractor does not initiate corrective measures within 5 calendar days of the inspection date or any extended period granted by the engineer, all work shall cease on the project except for work to correct these deficiencies, unless otherwise allowed by the engineer. All impact costs related to this halting of work, including, but not limited to stand-by time for equipment, shall be borne by the Contractor. Work shall not resume until the engineer approves the corrective work.

5.1 Liquidated Damages. If the Contractor fails to complete the correction of all Stormwater Deficiencies listed on the MoDOT Inspection Report within the specified time limit, the Commission will be damaged in various ways, including but not limited to, potential liability, required mitigation, environmental clean-up, fines, and penalties. These damages are not reasonably capable of being computed or quantified. Therefore, the contractor will be charged with liquidated damages specified in the amount of \$2,000 per day for failure to correct one or more of the Stormwater Deficiencies listed on the Inspection Report within the specified time limit. In addition to the stipulated damages, the stoppage of work shall remain in effect until all corrections are complete.

6.0 Basis of Payment. No direct payment will be made for compliance with this provision.

Delete Sec 106.9 in its entirety and substitute the following:

106.9 Buy America Requirements.

Buy America Requirements are waived if the total amount of Federal financial assistance applied to the project, through awards or subawards, is below \$500,000.

106.9.1 Buy America Requirements for Iron and Steel.

On all federal-aid projects, the contractor's attention is directed to Title 23 CFR 635.410 *Buy America Requirements*. Where steel or iron products are to be permanently incorporated into the contract work, steel and iron material shall be manufactured, from the initial melting stage through the application of coatings, in the USA except for "minimal use" as described herein. Furthermore, any coating process of the steel or iron shall be performed in the USA. Under a general waiver from FHWA the use of pig iron and processed, pelletized, and reduced iron ore manufactured outside of the USA will be permitted in the domestic manufacturing process for steel or iron material.

106.9.1.1 Buy America Requirements for Iron and Steel for Manufactured items.

A manufactured item will be considered iron and steel if it is "predominantly" iron or steel. Predominantly iron or steel means that the cost of iron or steel content of a product is more than 50 percent of the total cost of all its components.

106.9.2 Any sources other than the USA as defined will be considered foreign. The required domestic manufacturing process shall include formation of ingots and any subsequent process. Coatings shall include any surface finish that protects or adds value to the product.

106.9.3 "Minimal use" of foreign steel, iron or coating processes will be permitted, provided the cost of such products does not exceed 1/10 of one percent (0.1 percent) of the total contract cost or \$2,500.00, whichever is greater. If foreign steel, iron, or coating processes are used, invoices to document the cost of the foreign portion, as delivered to the project, shall be provided and the engineer's written approval obtained prior to placing the material in any work.

106.9.4 Buy America requirements include a step certification for all fabrication processes of all steel or iron materials that are accepted per Sec 1000. The AASHTO Product Evaluation and Audit Solutions compliance program verifies that all steel and iron products fabrication processes conform to 23 CFR 635.410 Buy America Requirements and is an acceptable standard per 23 CFR 635.410(d). AASHTO Product Evaluation and Audit Solutions compliant suppliers will not be required to submit step certification documentation with the shipment for some selected steel and iron materials. The AASHTO Product Evaluation and Audit Solutions compliant supplier shall maintain the step certification documentation on file and shall provide this documentation to the engineer upon request.

106.9.4.1 Items designated as Category 1 will consist of steel girders, piling, and reinforcing steel installed on site. Category 1 items require supporting documentation prior to incorporation into the project showing all steps of manufacturing, including coating, as being completed in the United States and in accordance with CFR Title 23 Section 635.410 Buy America Requirements. This includes the Mill Test Report from the original producing steel mill and certifications documenting the manufacturing process for all subsequent fabrication, including coatings. The certification shall include language that certifies the following. That all steel and iron materials permanently incorporated in this project was procured and processed domestically and all manufacturing processes, including coating, as being completed in the United States and in accordance with CFR Title 23 Section 635.410.

106.9.4.2 Items designated as Category 2 will include all other steel or iron products not in Category 1 and permanently incorporated in the project. Category 2 items shall consist of, but not be limited to items such as fencing, guardrail, signing, lighting and signal supports. The prime contractor is required to submit a material of origin form certification prior to incorporation into the project from the fabricator for each item that the product is domestic. The Certificate of Materials Origin form ([link to certificate form](#)) from the fabricator must show all steps of manufacturing, including coating, as being completed in the United States and in accordance with CFR Title 23 Section 635.410 Buy America Requirements and be signed by a fabricator representative. The engineer reserves the right to request additional information and documentation to verify that all Buy America requirements have been satisfied. These documents shall be submitted upon request by the engineer and retained for a period of 3 years after the last reimbursement of the material.

106.9.4.3 Any minor miscellaneous steel or iron items that are not included in the materials specifications shall be certified by the prime contractor as being procured domestically. Examples of these items would be bolts for sign posts, anchorage inserts, etc. The certification shall read "I certify that all steel and iron materials permanently incorporated in this project during all manufacturing processes, including coating, as being completed in the United States and in accordance with CFR Title 23 Section 635.410 Buy America Requirements procured and processed domestically in accordance with CFR Title 23 Section 635.410 Buy America Requirements. Any foreign steel used was submitted and accepted under minor usage". The certification shall be signed by an authorized representative of the prime contractor.

106.9.5 When permitted in the contract, alternate bids may be submitted for foreign steel and iron products. The award of the contract when alternate bids are permitted will be based on the lowest total bid of the contract based on furnishing domestic steel or iron products or 125 percent of the lowest total bid based on furnishing foreign steel or iron products. If foreign steel or iron products are awarded in the contract, domestic steel or iron products may be used; however, payment will be at the contract unit price for foreign steel or iron products.

106.9.6 Buy America Requirements for Construction Materials other than iron and steel materials. Construction materials means articles, materials, or supplies that consist of only one of the items listed. Minor additions of articles, materials, supplies, or binding agents to a construction material do not change the categorization of the construction material. Upon request by the engineer, the contractor shall submit a domestic certification for all construction materials listed that are incorporated into the project.

- (a) Non-ferrous metals
- (b) Plastic and Polymer-based products (including polyvinylchloride, composite building materials, and polymers used in fiber optic cables)
- (c) Glass (including optic glass)
- (d) Fiber optic cable (including drop cable)

- (e) Optical fiber
- (f) Lumber
- (g) Engineered wood
- (h) Drywall

106.9.6.1 Minimal Use allowance for Construction Materials other than iron or steel.

“The total value of the non-compliant products is no more than the lesser of \$1,000,000 or 5% of total applicable costs for the project.” The contractor shall submit to the engineer any non-domestic materials and their total material cost to the engineer. The contractor and the engineer will both track these totals to assure that the minimal usage allowance is not exceeded.

106.9.7 Buy America Requirements for Manufactured Products.

Manufactured products means:

- (a) Articles, materials, or supplies that have been:
 - (i) Processed into a specific form and shape; or
 - (ii) Combined with other articles, materials, or supplies to create a product with different properties than the individual articles, materials, or supplies.
- (b) If an item is classified as an iron or steel product, a construction material, or a section 70917(c) material under § 184.4(e) and the definitions set forth in this section, then it is not a manufactured product. However, an article, material, or supply classified as a manufactured product under § 184.4(e) and paragraph (1) of this definition may include components that are construction materials, iron or steel products, or section 70917(c) materials.

106.9.7.1 Manufactured products are exempt from Buy America requirements. To qualify as a manufactured product, items that consist of two or more of the listed construction materials that have been combined together through a manufacturing process, and items that include at least one of the listed materials combined with a material that is not listed through a manufacturing process, should be treated as manufactured products, rather than as construction materials.

106.9.7.2 Manufactured items are covered under a general waiver to exclude them from Buy America Requirements. To qualify for the exemption the components must comprise of 55% of the value of materials in the item. The final assembly must also be performed domestically.

Pavement Marking Paint Requirements for Standard Waterborne and Temporary

1.0 Description. High Build acrylic waterborne pavement marking paint shall be used in lieu of standard acrylic waterborne pavement marking paint for all Standard Waterborne Pavement Marking Paint items and all Temporary Pavement Marking Paint items. Paint thickness, bead type, bead application rate, retroreflectivity requirements, and all other specifications shall remain as stated in the Missouri Standard Specifications for Highway Construction, except as otherwise amended in the contract documents.

2.0 Material Requirements. Material requirements for Sec 620.20.2.5 Standard Waterborne Paint, and Sec 620.10.2 Temporary Pavement Marking Paint shall be per Sec 1048.20.1.2 High Build Acrylic Waterborne Pavement Marking Paint.

**REQUIRED CONTRACT PROVISIONS
FEDERAL-AID CONSTRUCTION CONTRACTS**

- I. General
- II. Nondiscrimination
- III. Non-segregated Facilities
- IV. Davis-Bacon and Related Act Provisions
- V. Contract Work Hours and Safety Standards Act Provisions
- VI. Subletting or Assigning the Contract
- VII. Safety: Accident Prevention
- VIII. False Statements Concerning Highway Projects
- IX. Implementation of Clean Air Act and Federal Water Pollution Control Act
- X. Certification Regarding Debarment, Suspension, Ineligibility and Voluntary Exclusion
- XI. Certification Regarding Use of Contract Funds for Lobbying
- XII. Use of United States-Flag Vessels:

ATTACHMENTS

A. Employment and Materials Preference for Appalachian Development Highway System or Appalachian Local Access Road Contracts (included in Appalachian contracts only)

I. GENERAL

1. Form FHWA-1273 must be physically incorporated in each construction contract funded under title 23, United States Code, as required in 23 CFR 633.102(b) (excluding emergency contracts solely intended for debris removal). The contractor (or subcontractor) must insert this form in each subcontract and further require its inclusion in all lower tier subcontracts (excluding purchase orders, rental agreements and other agreements for supplies or services). 23 CFR 633.102(e).

The applicable requirements of Form FHWA-1273 are incorporated by reference for work done under any purchase order, rental agreement or agreement for other services. The prime contractor shall be responsible for compliance by any subcontractor, lower-tier subcontractor or service provider. 23 CFR 633.102(e).

Form FHWA-1273 must be included in all Federal-aid design-build contracts, in all subcontracts and in lower tier subcontracts (excluding subcontracts for design services, purchase orders, rental agreements and other agreements for supplies or services) in accordance with 23 CFR 633.102. The design-builder shall be responsible for compliance by any subcontractor, lower-tier subcontractor or service provider.

Contracting agencies may reference Form FHWA-1273 in solicitation-for-bids or request-for-proposals documents, however, the Form FHWA-1273 must be physically incorporated (not referenced) in all contracts, subcontracts and lower-tier subcontracts (excluding purchase orders, rental agreements and other agreements for supplies or services related to a construction contract). 23 CFR 633.102(b).

2. Subject to the applicability criteria noted in the following sections, these contract provisions shall apply to all work

performed on the contract by the contractor's own organization and with the assistance of workers under the contractor's immediate superintendence and to all work performed on the contract by piecework, station work, or by subcontract. 23 CFR 633.102(d).

3. A breach of any of the stipulations contained in these Required Contract Provisions may be sufficient grounds for withholding of progress payments, withholding of final payment, termination of the contract, suspension / debarment or any other action determined to be appropriate by the contracting agency and FHWA.

4. Selection of Labor: During the performance of this contract, the contractor shall not use convict labor for any purpose within the limits of a construction project on a Federal-aid highway unless it is labor performed by convicts who are on parole, supervised release, or probation. 23 U.S.C. 114(b). The term Federal-aid highway does not include roadways functionally classified as local roads or rural minor collectors. 23 U.S.C. 101(a).

II. NONDISCRIMINATION (23 CFR 230.107(a); 23 CFR Part 230, Subpart A, Appendix A; EO 11246)

The provisions of this section related to 23 CFR Part 230, Subpart A, Appendix A are applicable to all Federal-aid construction contracts and to all related construction subcontracts of \$10,000 or more. The provisions of 23 CFR Part 230 are not applicable to material supply, engineering, or architectural service contracts.

In addition, the contractor and all subcontractors must comply with the following policies: Executive Order 11246, 41 CFR Part 60, 29 CFR Parts 1625-1627, 23 U.S.C. 140, Section 504 of the Rehabilitation Act of 1973, as amended (29 U.S.C. 794), Title VI of the Civil Rights Act of 1964, as amended (42 U.S.C. 2000d et seq.), and related regulations including 49 CFR Parts 21, 26, and 27; and 23 CFR Parts 200, 230, and 633.

The contractor and all subcontractors must comply with: the requirements of the Equal Opportunity Clause in 41 CFR 60-1.4(b) and, for all construction contracts exceeding \$10,000, the Standard Federal Equal Employment Opportunity Construction Contract Specifications in 41 CFR 60-4.3.

Note: The U.S. Department of Labor has exclusive authority to determine compliance with Executive Order 11246 and the policies of the Secretary of Labor including 41 CFR Part 60, and 29 CFR Parts 1625-1627. The contracting agency and the FHWA have the authority and the responsibility to ensure compliance with 23 U.S.C. 140, Section 504 of the Rehabilitation Act of 1973, as amended (29 U.S.C. 794), and Title VI of the Civil Rights Act of 1964, as amended (42 U.S.C. 2000d et seq.), and related regulations including 49 CFR Parts 21, 26, and 27; and 23 CFR Parts 200, 230, and 633.

The following provision is adopted from 23 CFR Part 230, Subpart A, Appendix A, with appropriate revisions to conform to the U.S. Department of Labor (US DOL) and FHWA requirements.

1. Equal Employment Opportunity: Equal Employment Opportunity (EEO) requirements not to discriminate and to take affirmative action to assure equal opportunity as set forth under laws, executive orders, rules, regulations (see 28 CFR Part 35, 29 CFR Part 1630, 29 CFR Parts 1625-1627, 41 CFR Part 60 and 49 CFR Part 27) and orders of the Secretary of Labor as modified by the provisions prescribed herein, and imposed pursuant to 23 U.S.C. 140, shall constitute the EEO and specific affirmative action standards for the contractor's project activities under this contract. The provisions of the Americans with Disabilities Act of 1990 (42 U.S.C. 12101 et seq.) set forth under 28 CFR Part 35 and 29 CFR Part 1630 are incorporated by reference in this contract. In the execution of this contract, the contractor agrees to comply with the following minimum specific requirement activities of EEO:

a. The contractor will work with the contracting agency and the Federal Government to ensure that it has made every good faith effort to provide equal opportunity with respect to all of its terms and conditions of employment and in their review of activities under the contract. 23 CFR 230.409 (g)(4) & (5).

b. The contractor will accept as its operating policy the following statement:

"It is the policy of this Company to assure that applicants are employed, and that employees are treated during employment, without regard to their race, religion, sex, sexual orientation, gender identity, color, national origin, age or disability. Such action shall include: employment, upgrading, demotion, or transfer; recruitment or recruitment advertising; layoff or termination; rates of pay or other forms of compensation; and selection for training, including apprenticeship, pre-apprenticeship, and/or on-the-job training."

2. EEO Officer: The contractor will designate and make known to the contracting officers an EEO Officer who will have the responsibility for and must be capable of effectively administering and promoting an active EEO program and who must be assigned adequate authority and responsibility to do so.

3. Dissemination of Policy: All members of the contractor's staff who are authorized to hire, supervise, promote, and discharge employees, or who recommend such action or are substantially involved in such action, will be made fully cognizant of and will implement the contractor's EEO policy and contractual responsibilities to provide EEO in each grade and classification of employment. To ensure that the above agreement will be met, the following actions will be taken as a minimum:

a. Periodic meetings of supervisory and personnel office employees will be conducted before the start of work and then not less often than once every six months, at which time the contractor's EEO policy and its implementation will be reviewed and explained. The meetings will be conducted by the EEO Officer or other knowledgeable company official.

b. All new supervisory or personnel office employees will be given a thorough indoctrination by the EEO Officer, covering all major aspects of the contractor's EEO obligations within thirty days following their reporting for duty with the contractor.

c. All personnel who are engaged in direct recruitment for the project will be instructed by the EEO Officer in the contractor's procedures for locating and hiring minorities and women.

d. Notices and posters setting forth the contractor's EEO policy will be placed in areas readily accessible to employees, applicants for employment and potential employees.

e. The contractor's EEO policy and the procedures to implement such policy will be brought to the attention of employees by means of meetings, employee handbooks, or other appropriate means.

4. Recruitment: When advertising for employees, the contractor will include in all advertisements for employees the notation: "An Equal Opportunity Employer." All such advertisements will be placed in publications having a large circulation among minorities and women in the area from which the project work force would normally be derived.

a. The contractor will, unless precluded by a valid bargaining agreement, conduct systematic and direct recruitment through public and private employee referral sources likely to yield qualified minorities and women. To meet this requirement, the contractor will identify sources of potential minority group employees and establish with such identified sources procedures whereby minority and women applicants may be referred to the contractor for employment consideration.

b. In the event the contractor has a valid bargaining agreement providing for exclusive hiring hall referrals, the contractor is expected to observe the provisions of that agreement to the extent that the system meets the contractor's compliance with EEO contract provisions. Where implementation of such an agreement has the effect of discriminating against minorities or women, or obligates the contractor to do the same, such implementation violates Federal nondiscrimination provisions.

c. The contractor will encourage its present employees to refer minorities and women as applicants for employment. Information and procedures with regard to referring such applicants will be discussed with employees.

5. Personnel Actions: Wages, working conditions, and employee benefits shall be established and administered, and personnel actions of every type, including hiring, upgrading, promotion, transfer, demotion, layoff, and termination, shall be taken without regard to race, color, religion, sex, sexual orientation, gender identity, national origin, age or disability. The following procedures shall be followed:

a. The contractor will conduct periodic inspections of project sites to ensure that working conditions and employee facilities do not indicate discriminatory treatment of project site personnel.

b. The contractor will periodically evaluate the spread of wages paid within each classification to determine any evidence of discriminatory wage practices.

c. The contractor will periodically review selected personnel actions in depth to determine whether there is evidence of discrimination. Where evidence is found, the contractor will promptly take corrective action. If the review indicates that the discrimination may extend beyond the actions reviewed, such corrective action shall include all affected persons.

d. The contractor will promptly investigate all complaints of alleged discrimination made to the contractor in connection with its obligations under this contract, will attempt to resolve such complaints, and will take appropriate corrective action

within a reasonable time. If the investigation indicates that the discrimination may affect persons other than the complainant, such corrective action shall include such other persons. Upon completion of each investigation, the contractor will inform every complainant of all of their avenues of appeal.

6. Training and Promotion:

a. The contractor will assist in locating, qualifying, and increasing the skills of minorities and women who are applicants for employment or current employees. Such efforts should be aimed at developing full journey level status employees in the type of trade or job classification involved.

b. Consistent with the contractor's work force requirements and as permissible under Federal and State regulations, the contractor shall make full use of training programs (i.e., apprenticeship and on-the-job training programs for the geographical area of contract performance). In the event a special provision for training is provided under this contract, this subparagraph will be superseded as indicated in the special provision. The contracting agency may reserve training positions for persons who receive welfare assistance in accordance with 23 U.S.C. 140(a).

c. The contractor will advise employees and applicants for employment of available training programs and entrance requirements for each.

d. The contractor will periodically review the training and promotion potential of employees who are minorities and women and will encourage eligible employees to apply for such training and promotion.

7. Unions: If the contractor relies in whole or in part upon unions as a source of employees, the contractor will use good faith efforts to obtain the cooperation of such unions to increase opportunities for minorities and women. 23 CFR 230.409. Actions by the contractor, either directly or through a contractor's association acting as agent, will include the procedures set forth below:

a. The contractor will use good faith efforts to develop, in cooperation with the unions, joint training programs aimed toward qualifying more minorities and women for membership in the unions and increasing the skills of minorities and women so that they may qualify for higher paying employment.

b. The contractor will use good faith efforts to incorporate an EEO clause into each union agreement to the end that such union will be contractually bound to refer applicants without regard to their race, color, religion, sex, sexual orientation, gender identity, national origin, age, or disability.

c. The contractor is to obtain information as to the referral practices and policies of the labor union except that to the extent such information is within the exclusive possession of the labor union and such labor union refuses to furnish such information to the contractor, the contractor shall so certify to the contracting agency and shall set forth what efforts have been made to obtain such information.

d. In the event the union is unable to provide the contractor with a reasonable flow of referrals within the time limit set forth in the collective bargaining agreement, the contractor will, through independent recruitment efforts, fill the employment vacancies without regard to race, color, religion, sex, sexual orientation, gender identity, national origin, age, or disability; making full efforts to obtain qualified and/or qualifiable minorities and women. The failure of a union to provide

sufficient referrals (even though it is obligated to provide exclusive referrals under the terms of a collective bargaining agreement) does not relieve the contractor from the requirements of this paragraph. In the event the union referral practice prevents the contractor from meeting the obligations pursuant to Executive Order 11246, as amended, and these special provisions, such contractor shall immediately notify the contracting agency.

8. Reasonable Accommodation for Applicants / Employees with Disabilities: The contractor must be familiar with the requirements for and comply with the Americans with Disabilities Act and all rules and regulations established thereunder. Employers must provide reasonable accommodation in all employment activities unless to do so would cause an undue hardship.

9. Selection of Subcontractors, Procurement of Materials and Leasing of Equipment: The contractor shall not discriminate on the grounds of race, color, religion, sex, sexual orientation, gender identity, national origin, age, or disability in the selection and retention of subcontractors, including procurement of materials and leases of equipment. The contractor shall take all necessary and reasonable steps to ensure nondiscrimination in the administration of this contract.

a. The contractor shall notify all potential subcontractors, suppliers, and lessors of their EEO obligations under this contract.

b. The contractor will use good faith efforts to ensure subcontractor compliance with their EEO obligations.

10. Assurances Required:

a. The requirements of 49 CFR Part 26 and the State DOT's FHWA-approved Disadvantaged Business Enterprise (DBE) program are incorporated by reference.

b. The contractor, subrecipient or subcontractor shall not discriminate on the basis of race, color, national origin, or sex in the performance of this contract. The contractor shall carry out applicable requirements of 49 CFR part 26 in the award and administration of DOT-assisted contracts. Failure by the contractor to carry out these requirements is a material breach of this contract, which may result in the termination of this contract or such other remedy as the recipient deems appropriate, which may include, but is not limited to:

- (1) Withholding monthly progress payments;
- (2) Assessing sanctions;
- (3) Liquidated damages; and/or
- (4) Disqualifying the contractor from future bidding as non-responsible.

c. The Title VI and nondiscrimination provisions of U.S. DOT Order 1050.2A at Appendixes A and E are incorporated by reference. 49 CFR Part 21.

11. Records and Reports: The contractor shall keep such records as necessary to document compliance with the EEO requirements. Such records shall be retained for a period of three years following the date of the final payment to the contractor for all contract work and shall be available at reasonable times and places for inspection by authorized representatives of the contracting agency and the FHWA.

a. The records kept by the contractor shall document the following:

(1) The number and work hours of minority and non-minority group members and women employed in each work classification on the project;

(2) The progress and efforts being made in cooperation with unions, when applicable, to increase employment opportunities for minorities and women; and

(3) The progress and efforts being made in locating, hiring, training, qualifying, and upgrading minorities and women.

b. The contractors and subcontractors will submit an annual report to the contracting agency each July for the duration of the project indicating the number of minority, women, and non-minority group employees currently engaged in each work classification required by the contract work. This information is to be reported on [Form FHWA-1391](#). The staffing data should represent the project work force on board in all or any part of the last payroll period preceding the end of July. If on-the-job training is being required by special provision, the contractor will be required to collect and report training data. The employment data should reflect the work force on board during all or any part of the last payroll period preceding the end of July.

III. NONSEGREGATED FACILITIES

This provision is applicable to all Federal-aid construction contracts and to all related construction subcontracts of more than \$10,000. 41 CFR 60-1.5.

As prescribed by 41 CFR 60-1.8, the contractor must ensure that facilities provided for employees are provided in such a manner that segregation on the basis of race, color, religion, sex, sexual orientation, gender identity, or national origin cannot result. The contractor may neither require such segregated use by written or oral policies nor tolerate such use by employee custom. The contractor's obligation extends further to ensure that its employees are not assigned to perform their services at any location under the contractor's control where the facilities are segregated. The term "facilities" includes waiting rooms, work areas, restaurants and other eating areas, time clocks, restrooms, washrooms, locker rooms and other storage or dressing areas, parking lots, drinking fountains, recreation or entertainment areas, transportation, and housing provided for employees. The contractor shall provide separate or single-user restrooms and necessary dressing or sleeping areas to assure privacy between sexes.

IV. DAVIS-BACON AND RELATED ACT PROVISIONS

This section is applicable to all Federal-aid construction projects exceeding \$2,000 and to all related subcontracts and lower-tier subcontracts (regardless of subcontract size), in accordance with 29 CFR 5.5. The requirements apply to all projects located within the right-of-way of a roadway that is functionally classified as Federal-aid highway. 23 U.S.C. 113. This excludes roadways functionally classified as local roads or rural minor collectors, which are exempt. 23 U.S.C. 101. Where applicable law requires that projects be treated as a project on a Federal-aid highway, the provisions of this subpart will apply regardless of the location of the project. Examples include: Surface Transportation Block Grant Program projects funded under 23 U.S.C. 133 [excluding recreational trails projects], the Nationally Significant Freight and Highway

Projects funded under 23 U.S.C. 117, and National Highway Freight Program projects funded under 23 U.S.C. 167.

The following provisions are from the U.S. Department of Labor regulations in 29 CFR 5.5 "Contract provisions and related matters" with minor revisions to conform to the FHWA-1273 format and FHWA program requirements.

1. Minimum wages (29 CFR 5.5)

a. *Wage rates and fringe benefits.* All laborers and mechanics employed or working upon the site of the work (or otherwise working in construction or development of the project under a development statute), will be paid unconditionally and not less often than once a week, and without subsequent deduction or rebate on any account (except such payroll deductions as are permitted by regulations issued by the Secretary of Labor under the Copeland Act ([29 CFR part 3](#))), the full amount of basic hourly wages and bona fide fringe benefits (or cash equivalents thereof) due at time of payment computed at rates not less than those contained in the wage determination of the Secretary of Labor which is attached hereto and made a part hereof, regardless of any contractual relationship which may be alleged to exist between the contractor and such laborers and mechanics. As provided in paragraphs (d) and (e) of 29 CFR 5.5, the appropriate wage determinations are effective by operation of law even if they have not been attached to the contract. Contributions made or costs reasonably anticipated for bona fide fringe benefits under the Davis-Bacon Act ([40 U.S.C. 3141\(2\)\(B\)](#)) on behalf of laborers or mechanics are considered wages paid to such laborers or mechanics, subject to the provisions of paragraph 1.e. of this section; also, regular contributions made or costs incurred for more than a weekly period (but not less often than quarterly) under plans, funds, or programs which cover the particular weekly period, are deemed to be constructively made or incurred during such weekly period. Such laborers and mechanics must be paid the appropriate wage rate and fringe benefits on the wage determination for the classification(s) of work actually performed, without regard to skill, except as provided in paragraph 4. of this section. Laborers or mechanics performing work in more than one classification may be compensated at the rate specified for each classification for the time actually worked therein: *Provided*, That the employer's payroll records accurately set forth the time spent in each classification in which work is performed. The wage determination (including any additional classifications and wage rates conformed under paragraph 1.c. of this section) and the Davis-Bacon poster (WH-1321) must be posted at all times by the contractor and its subcontractors at the site of the work in a prominent and accessible place where it can be easily seen by the workers.

b. *Frequently recurring classifications.* (1) In addition to wage and fringe benefit rates that have been determined to be prevailing under the procedures set forth in [29 CFR part 1](#), a wage determination may contain, pursuant to § 1.3(f), wage and fringe benefit rates for classifications of laborers and mechanics for which conformance requests are regularly submitted pursuant to paragraph 1.c. of this section, provided that:

(i) The work performed by the classification is not performed by a classification in the wage determination for which a prevailing wage rate has been determined;

(ii) The classification is used in the area by the construction industry; and

(iii) The wage rate for the classification bears a reasonable relationship to the prevailing wage rates contained in the wage determination.

(2) The Administrator will establish wage rates for such classifications in accordance with paragraph 1.c.(1)(iii) of this section. Work performed in such a classification must be paid at no less than the wage and fringe benefit rate listed on the wage determination for such classification.

c. *Conformance.* (1) The contracting officer must require that any class of laborers or mechanics, including helpers, which is not listed in the wage determination and which is to be employed under the contract be classified in conformance with the wage determination. Conformance of an additional classification and wage rate and fringe benefits is appropriate only when the following criteria have been met:

(i) The work to be performed by the classification requested is not performed by a classification in the wage determination; and

(ii) The classification is used in the area by the construction industry; and

(iii) The proposed wage rate, including any bona fide fringe benefits, bears a reasonable relationship to the wage rates contained in the wage determination.

(2) The conformance process may not be used to split, subdivide, or otherwise avoid application of classifications listed in the wage determination.

(3) If the contractor and the laborers and mechanics to be employed in the classification (if known), or their representatives, and the contracting officer agree on the classification and wage rate (including the amount designated for fringe benefits where appropriate), a report of the action taken will be sent by the contracting officer by email to DBAconformance@dol.gov. The Administrator, or an authorized representative, will approve, modify, or disapprove every additional classification action within 30 days of receipt and so advise the contracting officer or will notify the contracting officer within the 30-day period that additional time is necessary.

(4) In the event the contractor, the laborers or mechanics to be employed in the classification or their representatives, and the contracting officer do not agree on the proposed classification and wage rate (including the amount designated for fringe benefits, where appropriate), the contracting officer will, by email to DBAconformance@dol.gov, refer the questions, including the views of all interested parties and the recommendation of the contracting officer, to the Administrator for determination. The Administrator, or an authorized representative, will issue a determination within 30 days of receipt and so advise the contracting officer or will notify the contracting officer within the 30-day period that additional time is necessary.

(5) The contracting officer must promptly notify the contractor of the action taken by the Wage and Hour Division

under paragraphs 1.c.(3) and (4) of this section. The contractor must furnish a written copy of such determination to each affected worker or it must be posted as a part of the wage determination. The wage rate (including fringe benefits where appropriate) determined pursuant to paragraph 1.c.(3) or (4) of this section must be paid to all workers performing work in the classification under this contract from the first day on which work is performed in the classification.

d. *Fringe benefits not expressed as an hourly rate.* Whenever the minimum wage rate prescribed in the contract for a class of laborers or mechanics includes a fringe benefit which is not expressed as an hourly rate, the contractor may either pay the benefit as stated in the wage determination or may pay another bona fide fringe benefit or an hourly cash equivalent thereof.

e. *Unfunded plans.* If the contractor does not make payments to a trustee or other third person, the contractor may consider as part of the wages of any laborer or mechanic the amount of any costs reasonably anticipated in providing bona fide fringe benefits under a plan or program, *Provided*, That the Secretary of Labor has found, upon the written request of the contractor, in accordance with the criteria set forth in § 5.28, that the applicable standards of the Davis-Bacon Act have been met. The Secretary of Labor may require the contractor to set aside in a separate account assets for the meeting of obligations under the plan or program.

f. *Interest.* In the event of a failure to pay all or part of the wages required by the contract, the contractor will be required to pay interest on any underpayment of wages.

2. Withholding (29 CFR 5.5)

a. *Withholding requirements.* The contracting agency may, upon its own action, or must, upon written request of an authorized representative of the Department of Labor, withhold or cause to be withheld from the contractor so much of the accrued payments or advances as may be considered necessary to satisfy the liabilities of the prime contractor or any subcontractor for the full amount of wages and monetary relief, including interest, required by the clauses set forth in this section for violations of this contract, or to satisfy any such liabilities required by any other Federal contract, or federally assisted contract subject to Davis-Bacon labor standards, that is held by the same prime contractor (as defined in § 5.2). The necessary funds may be withheld from the contractor under this contract, any other Federal contract with the same prime contractor, or any other federally assisted contract that is subject to Davis-Bacon labor standards requirements and is held by the same prime contractor, regardless of whether the other contract was awarded or assisted by the same agency, and such funds may be used to satisfy the contractor liability for which the funds were withheld. In the event of a contractor's failure to pay any laborer or mechanic, including any apprentice or helper working on the site of the work all or part of the wages required by the contract, or upon the contractor's failure to submit the required records as discussed in paragraph 3.d. of this section, the contracting agency may on its own initiative and after written notice to the contractor, take such action as may be necessary to cause the suspension of any further payment, advance, or guarantee of funds until such violations have ceased.

b. *Priority to withheld funds.* The Department has priority to funds withheld or to be withheld in accordance with paragraph

2.a. of this section or Section V, paragraph 3.a., or both, over claims to those funds by:

- (1) A contractor's surety(ies), including without limitation performance bond sureties and payment bond sureties;
- (2) A contracting agency for its procurement costs;
- (3) A trustee(s) (either a court-appointed trustee or a U.S. trustee, or both) in bankruptcy of a contractor, or a contractor's bankruptcy estate;
- (4) A contractor's assignee(s);
- (5) A contractor's successor(s); or
- (6) A claim asserted under the Prompt Payment Act, [31 U.S.C. 3901–3907](#).

3. Records and certified payrolls (29 CFR 5.5)

a. *Basic record requirements (1) Length of record retention.* All regular payrolls and other basic records must be maintained by the contractor and any subcontractor during the course of the work and preserved for all laborers and mechanics working at the site of the work (or otherwise working in construction or development of the project under a development statute) for a period of at least 3 years after all the work on the prime contract is completed.

(2) *Information required.* Such records must contain the name; Social Security number; last known address, telephone number, and email address of each such worker; each worker's correct classification(s) of work actually performed; hourly rates of wages paid (including rates of contributions or costs anticipated for bona fide fringe benefits or cash equivalents thereof of the types described in [40 U.S.C. 3141\(2\)\(B\)](#) of the Davis-Bacon Act); daily and weekly number of hours actually worked in total and on each covered contract; deductions made; and actual wages paid.

(3) *Additional records relating to fringe benefits.* Whenever the Secretary of Labor has found under paragraph 1.e. of this section that the wages of any laborer or mechanic include the amount of any costs reasonably anticipated in providing benefits under a plan or program described in [40 U.S.C. 3141\(2\)\(B\)](#) of the Davis-Bacon Act, the contractor must maintain records which show that the commitment to provide such benefits is enforceable, that the plan or program is financially responsible, and that the plan or program has been communicated in writing to the laborers or mechanics affected, and records which show the costs anticipated or the actual cost incurred in providing such benefits.

(4) *Additional records relating to apprenticeship.* Contractors with apprentices working under approved programs must maintain written evidence of the registration of apprenticeship programs, the registration of the apprentices, and the ratios and wage rates prescribed in the applicable programs.

b. *Certified payroll requirements (1) Frequency and method of submission.* The contractor or subcontractor must submit weekly, for each week in which any DBA- or Related Acts-covered work is performed, certified payrolls to the contracting

agency. The prime contractor is responsible for the submission of all certified payrolls by all subcontractors. A contracting agency or prime contractor may permit or require contractors to submit certified payrolls through an electronic system, as long as the electronic system requires a legally valid electronic signature; the system allows the contractor, the contracting agency, and the Department of Labor to access the certified payrolls upon request for at least 3 years after the work on the prime contract has been completed; and the contracting agency or prime contractor permits other methods of submission in situations where the contractor is unable or limited in its ability to use or access the electronic system.

(2) *Information required.* The certified payrolls submitted must set out accurately and completely all of the information required to be maintained under paragraph 3.a.(2) of this section, except that full Social Security numbers and last known addresses, telephone numbers, and email addresses must not be included on weekly transmittals. Instead, the certified payrolls need only include an individually identifying number for each worker (e.g., the last four digits of the worker's Social Security number). The required weekly certified payroll information may be submitted using Optional Form WH-347 or in any other format desired. Optional Form WH-347 is available for this purpose from the Wage and Hour Division website at <https://www.dol.gov/sites/dolgov/files/WHD/legacy/files/wh347.pdf> or its successor website. It is not a violation of this section for a prime contractor to require a subcontractor to provide full Social Security numbers and last known addresses, telephone numbers, and email addresses to the prime contractor for its own records, without weekly submission by the subcontractor to the contracting agency.

(3) *Statement of Compliance.* Each certified payroll submitted must be accompanied by a "Statement of Compliance," signed by the contractor or subcontractor, or the contractor's or subcontractor's agent who pays or supervises the payment of the persons working on the contract, and must certify the following:

(i) That the certified payroll for the payroll period contains the information required to be provided under paragraph 3.b. of this section, the appropriate information and basic records are being maintained under paragraph 3.a. of this section, and such information and records are correct and complete;

(ii) That each laborer or mechanic (including each helper and apprentice) working on the contract during the payroll period has been paid the full weekly wages earned, without rebate, either directly or indirectly, and that no deductions have been made either directly or indirectly from the full wages earned, other than permissible deductions as set forth in [29 CFR part 3](#); and

(iii) That each laborer or mechanic has been paid not less than the applicable wage rates and fringe benefits or cash equivalents for the classification(s) of work actually performed, as specified in the applicable wage determination incorporated into the contract.

(4) *Use of Optional Form WH-347.* The weekly submission of a properly executed certification set forth on the reverse side of Optional Form WH-347 will satisfy the requirement for submission of the "Statement of Compliance" required by paragraph 3.b.(3) of this section.

(5) *Signature*. The signature by the contractor, subcontractor, or the contractor's or subcontractor's agent must be an original handwritten signature or a legally valid electronic signature.

(6) *Falsification*. The falsification of any of the above certifications may subject the contractor or subcontractor to civil or criminal prosecution under [18 U.S.C. 1001](#) and [31 U.S.C. 3729](#).

(7) *Length of certified payroll retention*. The contractor or subcontractor must preserve all certified payrolls during the course of the work and for a period of 3 years after all the work on the prime contract is completed.

c. *Contracts, subcontracts, and related documents*. The contractor or subcontractor must maintain this contract or subcontract and related documents including, without limitation, bids, proposals, amendments, modifications, and extensions. The contractor or subcontractor must preserve these contracts, subcontracts, and related documents during the course of the work and for a period of 3 years after all the work on the prime contract is completed.

d. *Required disclosures and access* (1) *Required record disclosures and access to workers*. The contractor or subcontractor must make the records required under paragraphs 3.a. through 3.c. of this section, and any other documents that the contracting agency, the State DOT, the FHWA, or the Department of Labor deems necessary to determine compliance with the labor standards provisions of any of the applicable statutes referenced by § 5.1, available for inspection, copying, or transcription by authorized representatives of the contracting agency, the State DOT, the FHWA, or the Department of Labor, and must permit such representatives to interview workers during working hours on the job.

(2) *Sanctions for non-compliance with records and worker access requirements*. If the contractor or subcontractor fails to submit the required records or to make them available, or refuses to permit worker interviews during working hours on the job, the Federal agency may, after written notice to the contractor, sponsor, applicant, owner, or other entity, as the case may be, that maintains such records or that employs such workers, take such action as may be necessary to cause the suspension of any further payment, advance, or guarantee of funds. Furthermore, failure to submit the required records upon request or to make such records available, or to permit worker interviews during working hours on the job, may be grounds for debarment action pursuant to § 5.12. In addition, any contractor or other person that fails to submit the required records or make those records available to WHD within the time WHD requests that the records be produced will be precluded from introducing as evidence in an administrative proceeding under [29 CFR part 6](#) any of the required records that were not provided or made available to WHD. WHD will take into consideration a reasonable request from the contractor or person for an extension of the time for submission of records. WHD will determine the reasonableness of the request and may consider, among other things, the location of the records and the volume of production.

(3) *Required information disclosures*. Contractors and subcontractors must maintain the full Social Security number and last known address, telephone number, and email address

of each covered worker, and must provide them upon request to the contracting agency, the State DOT, the FHWA, the contractor, or the Wage and Hour Division of the Department of Labor for purposes of an investigation or other compliance action.

4. Apprentices and equal employment opportunity (29 CFR 5.5)

a. *Apprentices* (1) *Rate of pay*. Apprentices will be permitted to work at less than the predetermined rate for the work they perform when they are employed pursuant to and individually registered in a bona fide apprenticeship program registered with the U.S. Department of Labor, Employment and Training Administration, Office of Apprenticeship (OA), or with a State Apprenticeship Agency recognized by the OA. A person who is not individually registered in the program, but who has been certified by the OA or a State Apprenticeship Agency (where appropriate) to be eligible for probationary employment as an apprentice, will be permitted to work at less than the predetermined rate for the work they perform in the first 90 days of probationary employment as an apprentice in such a program. In the event the OA or a State Apprenticeship Agency recognized by the OA withdraws approval of an apprenticeship program, the contractor will no longer be permitted to use apprentices at less than the applicable predetermined rate for the work performed until an acceptable program is approved.

(2) *Fringe benefits*. Apprentices must be paid fringe benefits in accordance with the provisions of the apprenticeship program. If the apprenticeship program does not specify fringe benefits, apprentices must be paid the full amount of fringe benefits listed on the wage determination for the applicable classification. If the Administrator determines that a different practice prevails for the applicable apprentice classification, fringe benefits must be paid in accordance with that determination.

(3) *Apprenticeship ratio*. The allowable ratio of apprentices to journeyworkers on the job site in any craft classification must not be greater than the ratio permitted to the contractor as to the entire work force under the registered program or the ratio applicable to the locality of the project pursuant to paragraph 4.a.(4) of this section. Any worker listed on a payroll at an apprentice wage rate, who is not registered or otherwise employed as stated in paragraph 4.a.(1) of this section, must be paid not less than the applicable wage rate on the wage determination for the classification of work actually performed. In addition, any apprentice performing work on the job site in excess of the ratio permitted under this section must be paid not less than the applicable wage rate on the wage determination for the work actually performed.

(4) *Reciprocity of ratios and wage rates*. Where a contractor is performing construction on a project in a locality other than the locality in which its program is registered, the ratios and wage rates (expressed in percentages of the journeyworker's hourly rate) applicable within the locality in which the construction is being performed must be observed. If there is no applicable ratio or wage rate for the locality of the project, the ratio and wage rate specified in the contractor's registered program must be observed.

b. *Equal employment opportunity*. The use of apprentices and journeyworkers under this part must be in conformity with

the equal employment opportunity requirements of Executive Order 11246, as amended, and [29 CFR part 30](#).

c. Apprentices and Trainees (programs of the U.S. DOT).

Apprentices and trainees working under apprenticeship and skill training programs which have been certified by the Secretary of Transportation as promoting EEO in connection with Federal-aid highway construction programs are not subject to the requirements of paragraph 4 of this Section IV. 23 CFR 230.111(e)(2). The straight time hourly wage rates for apprentices and trainees under such programs will be established by the particular programs. The ratio of apprentices and trainees to journeyworkers shall not be greater than permitted by the terms of the particular program.

5. Compliance with Copeland Act requirements. The contractor shall comply with the requirements of 29 CFR part 3, which are incorporated by reference in this contract as provided in 29 CFR 5.5.

6. Subcontracts. The contractor or subcontractor must insert FHWA-1273 in any subcontracts, along with the applicable wage determination(s) and such other clauses or contract modifications as the contracting agency may by appropriate instructions require, and a clause requiring the subcontractors to include these clauses and wage determination(s) in any lower tier subcontracts. The prime contractor is responsible for the compliance by any subcontractor or lower tier subcontractor with all the contract clauses in this section. In the event of any violations of these clauses, the prime contractor and any subcontractor(s) responsible will be liable for any unpaid wages and monetary relief, including interest from the date of the underpayment or loss, due to any workers of lower-tier subcontractors, and may be subject to debarment, as appropriate. 29 CFR 5.5.

7. Contract termination: debarment. A breach of the contract clauses in 29 CFR 5.5 may be grounds for termination of the contract, and for debarment as a contractor and a subcontractor as provided in 29 CFR 5.12.

8. Compliance with Davis-Bacon and Related Act requirements. All rulings and interpretations of the Davis-Bacon and Related Acts contained in 29 CFR parts 1, 3, and 5 are herein incorporated by reference in this contract as provided in 29 CFR 5.5.

9. Disputes concerning labor standards. As provided in 29 CFR 5.5, disputes arising out of the labor standards provisions of this contract shall not be subject to the general disputes clause of this contract. Such disputes shall be resolved in accordance with the procedures of the Department of Labor set forth in 29 CFR parts 5, 6, and 7. Disputes within the meaning of this clause include disputes between the contractor (or any of its subcontractors) and the contracting agency, the U.S. Department of Labor, or the employees or their representatives.

10. Certification of eligibility. a. By entering into this contract, the contractor certifies that neither it nor any person or firm who has an interest in the contractor's firm is a person or firm ineligible to be awarded Government contracts by virtue of [40 U.S.C. 3144\(b\)](#) or § 5.12(a).

b. No part of this contract shall be subcontracted to any person or firm ineligible for award of a Government contract by virtue of [40 U.S.C. 3144\(b\)](#) or § 5.12(a).

c. The penalty for making false statements is prescribed in the U.S. Code, Title 18 Crimes and Criminal Procedure, [18 U.S.C. 1001](#).

11. Anti-retaliation. It is unlawful for any person to discharge, demote, intimidate, threaten, restrain, coerce, blacklist, harass, or in any other manner discriminate against, or to cause any person to discharge, demote, intimidate, threaten, restrain, coerce, blacklist, harass, or in any other manner discriminate against, any worker or job applicant for:

a. Notifying any contractor of any conduct which the worker reasonably believes constitutes a violation of the DBA, Related Acts, this part, or [29 CFR part 1](#) or [3](#);

b. Filing any complaint, initiating or causing to be initiated any proceeding, or otherwise asserting or seeking to assert on behalf of themselves or others any right or protection under the DBA, Related Acts, this part, or [29 CFR part 1](#) or [3](#);

c. Cooperating in any investigation or other compliance action, or testifying in any proceeding under the DBA, Related Acts, this part, or [29 CFR part 1](#) or [3](#); or

d. Informing any other person about their rights under the DBA, Related Acts, this part, or [29 CFR part 1](#) or [3](#).

V. CONTRACT WORK HOURS AND SAFETY STANDARDS ACT

Pursuant to 29 CFR 5.5(b), the following clauses apply to any Federal-aid construction contract in an amount in excess of \$100,000 and subject to the overtime provisions of the Contract Work Hours and Safety Standards Act. These clauses shall be inserted in addition to the clauses required by 29 CFR 5.5(a) or 29 CFR 4.6. As used in this paragraph, the terms laborers and mechanics include watchpersons and guards.

1. Overtime requirements. No contractor or subcontractor contracting for any part of the contract work which may require or involve the employment of laborers or mechanics shall require or permit any such laborer or mechanic in any workweek in which he or she is employed on such work to work in excess of forty hours in such workweek unless such laborer or mechanic receives compensation at a rate not less than one and one-half times the basic rate of pay for all hours worked in excess of forty hours in such workweek. 29 CFR 5.5.

2. Violation; liability for unpaid wages; liquidated damages. In the event of any violation of the clause set forth in paragraph 1. of this section the contractor and any subcontractor responsible therefor shall be liable for the unpaid wages and interest from the date of the underpayment. In addition, such contractor and subcontractor shall be liable to the United States (in the case of work done under contract for the District of Columbia or a territory, to such District or to such territory), for liquidated damages. Such liquidated damages shall be computed with respect to each individual laborer or

mechanic, including watchpersons and guards, employed in violation of the clause set forth in paragraph 1. of this section, in the sum currently provided in 29 CFR 5.5(b)(2)* for each calendar day on which such individual was required or permitted to work in excess of the standard workweek of forty hours without payment of the overtime wages required by the clause set forth in paragraph 1. of this section.

* \$31 as of January 15, 2023 (See 88 FR 88 FR 2210) as may be adjusted annually by the Department of Labor, pursuant to the Federal Civil Penalties Inflation Adjustment Act of 1990.

3. Withholding for unpaid wages and liquidated damages

a. *Withholding process.* The FHWA or the contracting agency may, upon its own action, or must, upon written request of an authorized representative of the Department of Labor, withhold or cause to be withheld from the contractor so much of the accrued payments or advances as may be considered necessary to satisfy the liabilities of the prime contractor or any subcontractor for any unpaid wages; monetary relief, including interest; and liquidated damages required by the clauses set forth in this section on this contract, any other Federal contract with the same prime contractor, or any other federally assisted contract subject to the Contract Work Hours and Safety Standards Act that is held by the same prime contractor (as defined in § 5.2). The necessary funds may be withheld from the contractor under this contract, any other Federal contract with the same prime contractor, or any other federally assisted contract that is subject to the Contract Work Hours and Safety Standards Act and is held by the same prime contractor, regardless of whether the other contract was awarded or assisted by the same agency, and such funds may be used to satisfy the contractor liability for which the funds were withheld.

b. *Priority to withheld funds.* The Department has priority to funds withheld or to be withheld in accordance with Section IV paragraph 2.a. or paragraph 3.a. of this section, or both, over claims to those funds by:

- (1) A contractor's surety(ies), including without limitation performance bond sureties and payment bond sureties;
- (2) A contracting agency for its procurement costs;
- (3) A trustee(s) (either a court-appointed trustee or a U.S. trustee, or both) in bankruptcy of a contractor, or a contractor's bankruptcy estate;
- (4) A contractor's assignee(s);
- (5) A contractor's successor(s); or
- (6) A claim asserted under the Prompt Payment Act, [31 U.S.C. 3901](#)–3907.

4. Subcontracts. The contractor or subcontractor must insert in any subcontracts the clauses set forth in paragraphs 1. through 5. of this section and a clause requiring the subcontractors to include these clauses in any lower tier subcontracts. The prime contractor is responsible for compliance by any subcontractor or lower tier subcontractor with the clauses set forth in paragraphs 1. through 5. In the

event of any violations of these clauses, the prime contractor and any subcontractor(s) responsible will be liable for any unpaid wages and monetary relief, including interest from the date of the underpayment or loss, due to any workers of lower-tier subcontractors, and associated liquidated damages and may be subject to debarment, as appropriate.

5. Anti-retaliation. It is unlawful for any person to discharge, demote, intimidate, threaten, restrain, coerce, blacklist, harass, or in any other manner discriminate against, or to cause any person to discharge, demote, intimidate, threaten, restrain, coerce, blacklist, harass, or in any other manner discriminate against, any worker or job applicant for:

a. Notifying any contractor of any conduct which the worker reasonably believes constitutes a violation of the Contract Work Hours and Safety Standards Act (CWHSSA) or its implementing regulations in this part;

b. Filing any complaint, initiating or causing to be initiated any proceeding, or otherwise asserting or seeking to assert on behalf of themselves or others any right or protection under CWHSSA or this part;

c. Cooperating in any investigation or other compliance action, or testifying in any proceeding under CWHSSA or this part; or

d. Informing any other person about their rights under CWHSSA or this part.

VI. SUBLETTING OR ASSIGNING THE CONTRACT

This provision is applicable to all Federal-aid construction contracts on the National Highway System pursuant to 23 CFR 635.116.

1. The contractor shall perform with its own organization contract work amounting to not less than 30 percent (or a greater percentage if specified elsewhere in the contract) of the total original contract price, excluding any specialty items designated by the contracting agency. Specialty items may be performed by subcontract and the amount of any such specialty items performed may be deducted from the total original contract price before computing the amount of work required to be performed by the contractor's own organization (23 CFR 635.116).

a. The term "perform work with its own organization" in paragraph 1 of Section VI refers to workers employed or leased by the prime contractor, and equipment owned or rented by the prime contractor, with or without operators. Such term does not include employees or equipment of a subcontractor or lower tier subcontractor, agents of the prime contractor, or any other assignees. The term may include payments for the costs of hiring leased employees from an employee leasing firm meeting all relevant Federal and State regulatory requirements. Leased employees may only be included in this term if the prime contractor meets all of the following conditions: (based on longstanding interpretation)

- (1) the prime contractor maintains control over the supervision of the day-to-day activities of the leased employees;
- (2) the prime contractor remains responsible for the quality of the work of the leased employees;

- (3) the prime contractor retains all power to accept or exclude individual employees from work on the project; and
- (4) the prime contractor remains ultimately responsible for the payment of predetermined minimum wages, the submission of payrolls, statements of compliance and all other Federal regulatory requirements.

b. "Specialty Items" shall be construed to be limited to work that requires highly specialized knowledge, abilities, or equipment not ordinarily available in the type of contracting organizations qualified and expected to bid or propose on the contract as a whole and in general are to be limited to minor components of the overall contract. 23 CFR 635.102.

2. Pursuant to 23 CFR 635.116(a), the contract amount upon which the requirements set forth in paragraph (1) of Section VI is computed includes the cost of material and manufactured products which are to be purchased or produced by the contractor under the contract provisions.

3. Pursuant to 23 CFR 635.116(c), the contractor shall furnish (a) a competent superintendent or supervisor who is employed by the firm, has full authority to direct performance of the work in accordance with the contract requirements, and is in charge of all construction operations (regardless of who performs the work) and (b) such other of its own organizational resources (supervision, management, and engineering services) as the contracting officer determines is necessary to assure the performance of the contract.

4. No portion of the contract shall be sublet, assigned or otherwise disposed of except with the written consent of the contracting officer, or authorized representative, and such consent when given shall not be construed to relieve the contractor of any responsibility for the fulfillment of the contract. Written consent will be given only after the contracting agency has assured that each subcontract is evidenced in writing and that it contains all pertinent provisions and requirements of the prime contract. (based on long-standing interpretation of 23 CFR 635.116).

5. The 30-percent self-performance requirement of paragraph (1) is not applicable to design-build contracts; however, contracting agencies may establish their own self-performance requirements. 23 CFR 635.116(d).

VII. SAFETY: ACCIDENT PREVENTION

This provision is applicable to all Federal-aid construction contracts and to all related subcontracts.

1. In the performance of this contract the contractor shall comply with all applicable Federal, State, and local laws governing safety, health, and sanitation (23 CFR Part 635). The contractor shall provide all safeguards, safety devices and protective equipment and take any other needed actions as it determines, or as the contracting officer may determine, to be reasonably necessary to protect the life and health of employees on the job and the safety of the public and to protect property in connection with the performance of the work covered by the contract. 23 CFR 635.108.

2. It is a condition of this contract, and shall be made a condition of each subcontract, which the contractor enters into pursuant to this contract, that the contractor and any subcontractor shall not permit any employee, in performance of the contract, to work in surroundings or under conditions which are unsanitary, hazardous or dangerous to his/her health or safety, as determined under construction safety and

health standards (29 CFR Part 1926) promulgated by the Secretary of Labor, in accordance with Section 107 of the Contract Work Hours and Safety Standards Act (40 U.S.C. 3704). 29 CFR 1926.10.

3. Pursuant to 29 CFR 1926.3, it is a condition of this contract that the Secretary of Labor or authorized representative thereof, shall have right of entry to any site of contract performance to inspect or investigate the matter of compliance with the construction safety and health standards and to carry out the duties of the Secretary under Section 107 of the Contract Work Hours and Safety Standards Act (40 U.S.C. 3704).

VIII. FALSE STATEMENTS CONCERNING HIGHWAY PROJECTS

This provision is applicable to all Federal-aid construction contracts and to all related subcontracts.

In order to assure high quality and durable construction in conformity with approved plans and specifications and a high degree of reliability on statements and representations made by engineers, contractors, suppliers, and workers on Federal-aid highway projects, it is essential that all persons concerned with the project perform their functions as carefully, thoroughly, and honestly as possible. Willful falsification, distortion, or misrepresentation with respect to any facts related to the project is a violation of Federal law. To prevent any misunderstanding regarding the seriousness of these and similar acts, Form FHWA-1022 shall be posted on each Federal-aid highway project (23 CFR Part 635) in one or more places where it is readily available to all persons concerned with the project:

18 U.S.C. 1020 reads as follows:

"Whoever, being an officer, agent, or employee of the United States, or of any State or Territory, or whoever, whether a person, association, firm, or corporation, knowingly makes any false statement, false representation, or false report as to the character, quality, quantity, or cost of the material used or to be used, or the quantity or quality of the work performed or to be performed, or the cost thereof in connection with the submission of plans, maps, specifications, contracts, or costs of construction on any highway or related project submitted for approval to the Secretary of Transportation; or

Whoever knowingly makes any false statement, false representation, false report or false claim with respect to the character, quality, quantity, or cost of any work performed or to be performed, or materials furnished or to be furnished, in connection with the construction of any highway or related project approved by the Secretary of Transportation; or

Whoever knowingly makes any false statement or false representation as to material fact in any statement, certificate, or report submitted pursuant to provisions of the Federal-aid Roads Act approved July 11, 1916, (39 Stat. 355), as amended and supplemented;

Shall be fined under this title or imprisoned not more than 5 years or both."

IX. IMPLEMENTATION OF CLEAN AIR ACT AND FEDERAL WATER POLLUTION CONTROL ACT (42 U.S.C. 7606; 2 CFR 200.88; EO 11738)

This provision is applicable to all Federal-aid construction contracts in excess of \$150,000 and to all related subcontracts. 48 CFR 2.101; 2 CFR 200.327.

By submission of this bid/proposal or the execution of this contract or subcontract, as appropriate, the bidder, proposer, Federal-aid construction contractor, subcontractor, supplier, or vendor agrees to comply with all applicable standards, orders or regulations issued pursuant to the Clean Air Act (42 U.S.C. 7401-7671q) and the Federal Water Pollution Control Act, as amended (33 U.S.C. 1251-1387). Violations must be reported to the Federal Highway Administration and the Regional Office of the Environmental Protection Agency. 2 CFR Part 200, Appendix II.

The contractor agrees to include or cause to be included the requirements of this Section in every subcontract, and further agrees to take such action as the contracting agency may direct as a means of enforcing such requirements. 2 CFR 200.327.

X. CERTIFICATION REGARDING DEBARMENT, SUSPENSION, INELIGIBILITY AND VOLUNTARY EXCLUSION

This provision is applicable to all Federal-aid construction contracts, design-build contracts, subcontracts, lower-tier subcontracts, purchase orders, lease agreements, consultant contracts or any other covered transaction requiring FHWA approval or that is estimated to cost \$25,000 or more – as defined in 2 CFR Parts 180 and 1200. 2 CFR 180.220 and 1200.220.

1. Instructions for Certification – First Tier Participants:

- a. By signing and submitting this proposal, the prospective first tier participant is providing the certification set out below.
- b. The inability of a person to provide the certification set out below will not necessarily result in denial of participation in this covered transaction. The prospective first tier participant shall submit an explanation of why it cannot provide the certification set out below. The certification or explanation will be considered in connection with the department or agency's determination whether to enter into this transaction. However, failure of the prospective first tier participant to furnish a certification or an explanation shall disqualify such a person from participation in this transaction. 2 CFR 180.320.
- c. The certification in this clause is a material representation of fact upon which reliance was placed when the contracting agency determined to enter into this transaction. If it is later determined that the prospective participant knowingly rendered an erroneous certification, in addition to other remedies available to the Federal Government, the contracting agency may terminate this transaction for cause of default. 2 CFR 180.325.
- d. The prospective first tier participant shall provide immediate written notice to the contracting agency to whom this proposal is submitted if any time the prospective first tier participant learns that its certification was erroneous when submitted or has become erroneous by reason of changed circumstances. 2 CFR 180.345 and 180.350.

e. The terms "covered transaction," "debarred," "suspended," "ineligible," "participant," "person," "principal," and "voluntarily excluded," as used in this clause, are defined in 2 CFR Parts 180, Subpart I, 180.900-180.1020, and 1200. "First Tier Covered Transactions" refers to any covered transaction between a recipient or subrecipient of Federal funds and a participant (such as the prime or general contract). "Lower Tier Covered Transactions" refers to any covered transaction under a First Tier Covered Transaction (such as subcontracts). "First Tier Participant" refers to the participant who has entered into a covered transaction with a recipient or subrecipient of Federal funds (such as the prime or general contractor). "Lower Tier Participant" refers any participant who has entered into a covered transaction with a First Tier Participant or other Lower Tier Participants (such as subcontractors and suppliers).

f. The prospective first tier participant agrees by submitting this proposal that, should the proposed covered transaction be entered into, it shall not knowingly enter into any lower tier covered transaction with a person who is debarred, suspended, declared ineligible, or voluntarily excluded from participation in this covered transaction, unless authorized by the department or agency entering into this transaction. 2 CFR 180.330.

g. The prospective first tier participant further agrees by submitting this proposal that it will include the clause titled "Certification Regarding Debarment, Suspension, Ineligibility and Voluntary Exclusion-Lower Tier Covered Transactions," provided by the department or contracting agency, entering into this covered transaction, without modification, in all lower tier covered transactions and in all solicitations for lower tier covered transactions exceeding the \$25,000 threshold. 2 CFR 180.220 and 180.300.

h. A participant in a covered transaction may rely upon a certification of a prospective participant in a lower tier covered transaction that is not debarred, suspended, ineligible, or voluntarily excluded from the covered transaction, unless it knows that the certification is erroneous. 2 CFR 180.300; 180.320, and 180.325. A participant is responsible for ensuring that its principals are not suspended, debarred, or otherwise ineligible to participate in covered transactions. 2 CFR 180.335. To verify the eligibility of its principals, as well as the eligibility of any lower tier prospective participants, each participant may, but is not required to, check the System for Award Management website (<https://www.sam.gov/>). 2 CFR 180.300, 180.320, and 180.325.

i. Nothing contained in the foregoing shall be construed to require the establishment of a system of records in order to render in good faith the certification required by this clause. The knowledge and information of the prospective participant is not required to exceed that which is normally possessed by a prudent person in the ordinary course of business dealings.

j. Except for transactions authorized under paragraph (f) of these instructions, if a participant in a covered transaction knowingly enters into a lower tier covered transaction with a person who is suspended, debarred, ineligible, or voluntarily excluded from participation in this transaction, in addition to other remedies available to the Federal Government, the department or agency may terminate this transaction for cause or default. 2 CFR 180.325.

* * * * *

2. Certification Regarding Debarment, Suspension, Ineligibility and Voluntary Exclusion – First Tier Participants:

a. The prospective first tier participant certifies to the best of its knowledge and belief, that it and its principals:

(1) Are not presently debarred, suspended, proposed for debarment, declared ineligible, or voluntarily excluded from participating in covered transactions by any Federal department or agency, 2 CFR 180.335;.

(2) Have not within a three-year period preceding this proposal been convicted of or had a civil judgment rendered against them for commission of fraud or a criminal offense in connection with obtaining, attempting to obtain, or performing a public (Federal, State, or local) transaction or contract under a public transaction; violation of Federal or State antitrust statutes or commission of embezzlement, theft, forgery, bribery, falsification or destruction of records, making false statements, or receiving stolen property, 2 CFR 180.800;

(3) Are not presently indicted for or otherwise criminally or civilly charged by a governmental entity (Federal, State or local) with commission of any of the offenses enumerated in paragraph (a)(2) of this certification, 2 CFR 180.700 and 180.800; and

(4) Have not within a three-year period preceding this application/proposal had one or more public transactions (Federal, State or local) terminated for cause or default. 2 CFR 180.335(d).

(5) Are not a corporation that has been convicted of a felony violation under any Federal law within the two-year period preceding this proposal (USDOT Order 4200.6 implementing appropriations act requirements); and

(6) Are not a corporation with any unpaid Federal tax liability that has been assessed, for which all judicial and administrative remedies have been exhausted, or have lapsed, and that is not being paid in a timely manner pursuant to an agreement with the authority responsible for collecting the tax liability (USDOT Order 4200.6 implementing appropriations act requirements).

b. Where the prospective participant is unable to certify to any of the statements in this certification, such prospective participant should attach an explanation to this proposal. 2 CFR 180.335 and 180.340.

3. Instructions for Certification - Lower Tier Participants:

(Applicable to all subcontracts, purchase orders, and other lower tier transactions requiring prior FHWA approval or estimated to cost \$25,000 or more - 2 CFR Parts 180 and 1200). 2 CFR 180.220 and 1200.220.

a. By signing and submitting this proposal, the prospective lower tier participant is providing the certification set out below.

b. The certification in this clause is a material representation of fact upon which reliance was placed when this transaction was entered into. If it is later determined that the prospective lower tier participant knowingly rendered an erroneous certification, in addition to other remedies available to the Federal Government, the department, or agency with which

this transaction originated may pursue available remedies, including suspension and/or debarment.

c. The prospective lower tier participant shall provide immediate written notice to the person to which this proposal is submitted if at any time the prospective lower tier participant learns that its certification was erroneous by reason of changed circumstances. 2 CFR 180.365.

d. The terms "covered transaction," "debarred," "suspended," "ineligible," "participant," "person," "principal," and "voluntarily excluded," as used in this clause, are defined in 2 CFR Parts 180, Subpart I, 180.900 – 180.1020, and 1200. You may contact the person to which this proposal is submitted for assistance in obtaining a copy of those regulations. "First Tier Covered Transactions" refers to any covered transaction between a recipient or subrecipient of Federal funds and a participant (such as the prime or general contract). "Lower Tier Covered Transactions" refers to any covered transaction under a First Tier Covered Transaction (such as subcontracts). "First Tier Participant" refers to the participant who has entered into a covered transaction with a recipient or subrecipient of Federal funds (such as the prime or general contractor). "Lower Tier Participant" refers any participant who has entered into a covered transaction with a First Tier Participant or other Lower Tier Participants (such as subcontractors and suppliers).

e. The prospective lower tier participant agrees by submitting this proposal that, should the proposed covered transaction be entered into, it shall not knowingly enter into any lower tier covered transaction with a person who is debarred, suspended, declared ineligible, or voluntarily excluded from participation in this covered transaction, unless authorized by the department or agency with which this transaction originated. 2 CFR 1200.220 and 1200.332.

f. The prospective lower tier participant further agrees by submitting this proposal that it will include this clause titled "Certification Regarding Debarment, Suspension, Ineligibility and Voluntary Exclusion-Lower Tier Covered Transaction," without modification, in all lower tier covered transactions and in all solicitations for lower tier covered transactions exceeding the \$25,000 threshold. 2 CFR 180.220 and 1200.220.

g. A participant in a covered transaction may rely upon a certification of a prospective participant in a lower tier covered transaction that is not debarred, suspended, ineligible, or voluntarily excluded from the covered transaction, unless it knows that the certification is erroneous. A participant is responsible for ensuring that its principals are not suspended, debarred, or otherwise ineligible to participate in covered transactions. To verify the eligibility of its principals, as well as the eligibility of any lower tier prospective participants, each participant may, but is not required to, check the System for Award Management website (<https://www.sam.gov/>), which is compiled by the General Services Administration. 2 CFR 180.300, 180.320, 180.330, and 180.335.

h. Nothing contained in the foregoing shall be construed to require establishment of a system of records in order to render in good faith the certification required by this clause. The knowledge and information of participant is not required to exceed that which is normally possessed by a prudent person in the ordinary course of business dealings.

i. Except for transactions authorized under paragraph e of these instructions, if a participant in a covered transaction knowingly enters into a lower tier covered transaction with a person who is suspended, debarred, ineligible, or voluntarily

excluded from participation in this transaction, in addition to other remedies available to the Federal Government, the department or agency with which this transaction originated may pursue available remedies, including suspension and/or debarment. 2 CFR 180.325.

4. Certification Regarding Debarment, Suspension, Ineligibility and Voluntary Exclusion--Lower Tier Participants:

a. The prospective lower tier participant certifies, by submission of this proposal, that neither it nor its principals:

(1) is presently debarred, suspended, proposed for debarment, declared ineligible, or voluntarily excluded from participating in covered transactions by any Federal department or agency, 2 CFR 180.355;

(2) is a corporation that has been convicted of a felony violation under any Federal law within the two-year period preceding this proposal (USDOT Order 4200.6 implementing appropriations act requirements); and

(3) is a corporation with any unpaid Federal tax liability that has been assessed, for which all judicial and administrative remedies have been exhausted, or have lapsed, and that is not being paid in a timely manner pursuant to an agreement with the authority responsible for collecting the tax liability. (USDOT Order 4200.6 implementing appropriations act requirements)

b. Where the prospective lower tier participant is unable to certify to any of the statements in this certification, such prospective participant should attach an explanation to this proposal.

XI. CERTIFICATION REGARDING USE OF CONTRACT FUNDS FOR LOBBYING

This provision is applicable to all Federal-aid construction contracts and to all related subcontracts which exceed \$100,000. 49 CFR Part 20, App. A.

1. The prospective participant certifies, by signing and submitting this bid or proposal, to the best of his or her knowledge and belief, that:

a. No Federal appropriated funds have been paid or will be paid, by or on behalf of the undersigned, to any person for influencing or attempting to influence an officer or employee of any Federal agency, a Member of Congress, an officer or employee of Congress, or an employee of a Member of Congress in connection with the awarding of any Federal contract, the making of any Federal grant, the making of any Federal loan, the entering into of any cooperative agreement, and the extension, continuation, renewal, amendment, or modification of any Federal contract, grant, loan, or cooperative agreement.

b. If any funds other than Federal appropriated funds have been paid or will be paid to any person for influencing or attempting to influence an officer or employee of any Federal agency, a Member of Congress, an officer or employee of Congress, or an employee of a Member of Congress in connection with this Federal contract, grant, loan, or

cooperative agreement, the undersigned shall complete and submit Standard Form-LLL, "Disclosure Form to Report Lobbying," in accordance with its instructions.

2. This certification is a material representation of fact upon which reliance was placed when this transaction was made or entered into. Submission of this certification is a prerequisite for making or entering into this transaction imposed by 31 U.S.C. 1352. Any person who fails to file the required certification shall be subject to a civil penalty of not less than \$10,000 and not more than \$100,000 for each such failure.

3. The prospective participant also agrees by submitting its bid or proposal that the participant shall require that the language of this certification be included in all lower tier subcontracts, which exceed \$100,000 and that all such recipients shall certify and disclose accordingly.

XII. USE OF UNITED STATES-FLAG VESSELS:

This provision is applicable to all Federal-aid construction contracts, design-build contracts, subcontracts, lower-tier subcontracts, purchase orders, lease agreements, or any other covered transaction. 46 CFR Part 381.

This requirement applies to material or equipment that is acquired for a specific Federal-aid highway project. 46 CFR 381.7. It is not applicable to goods or materials that come into inventories independent of an FHWA funded-contract.

When oceanic shipments (or shipments across the Great Lakes) are necessary for materials or equipment acquired for a specific Federal-aid construction project, the bidder, proposer, contractor, subcontractor, or vendor agrees:

1. To utilize privately owned United States-flag commercial vessels to ship at least 50 percent of the gross tonnage (computed separately for dry bulk carriers, dry cargo liners, and tankers) involved, whenever shipping any equipment, material, or commodities pursuant to this contract, to the extent such vessels are available at fair and reasonable rates for United States-flag commercial vessels. 46 CFR 381.7.

2. To furnish within 20 days following the date of loading for shipments originating within the United States or within 30 working days following the date of loading for shipments originating outside the United States, a legible copy of a rated, 'on-board' commercial ocean bill-of-lading in English for each shipment of cargo described in paragraph (b)(1) of this section to both the Contracting Officer (through the prime contractor in the case of subcontractor bills-of-lading) and to the Office of Cargo and Commercial Sealift (MAR-620), Maritime Administration, Washington, DC 20590. (MARAD requires copies of the ocean carrier's (master) bills of lading, certified onboard, dated, with rates and charges. These bills of lading may contain business sensitive information and therefore may be submitted directly to MARAD by the Ocean Transportation Intermediary on behalf of the contractor). 46 CFR 381.7.

**ATTACHMENT A - EMPLOYMENT AND MATERIALS
PREFERENCE FOR APPALACHIAN DEVELOPMENT
HIGHWAY SYSTEM OR APPALACHIAN LOCAL ACCESS
ROAD CONTRACTS (23 CFR 633, Subpart B, Appendix B)**

This provision is applicable to all Federal-aid projects funded under the Appalachian Regional Development Act of 1965.

1. During the performance of this contract, the contractor undertaking to do work which is, or reasonably may be, done as on-site work, shall give preference to qualified persons who regularly reside in the labor area as designated by the DOL wherein the contract work is situated, or the subregion, or the Appalachian counties of the State wherein the contract work is situated, except:

a. To the extent that qualified persons regularly residing in the area are not available.

b. For the reasonable needs of the contractor to employ supervisory or specially experienced personnel necessary to assure an efficient execution of the contract work.

c. For the obligation of the contractor to offer employment to present or former employees as the result of a lawful collective bargaining contract, provided that the number of nonresident persons employed under this subparagraph (1c) shall not exceed 20 percent of the total number of employees employed by the contractor on the contract work, except as provided in subparagraph (4) below.

2. The contractor shall place a job order with the State Employment Service indicating (a) the classifications of the laborers, mechanics and other employees required to perform the contract work, (b) the number of employees required in each classification, (c) the date on which the participant estimates such employees will be required, and (d) any other pertinent information required by the State Employment Service to complete the job order form. The job order may be placed with the State Employment Service in writing or by telephone. If during the course of the contract work, the information submitted by the contractor in the original job order is substantially modified, the participant shall promptly notify the State Employment Service.

3. The contractor shall give full consideration to all qualified job applicants referred to him by the State Employment Service. The contractor is not required to grant employment to any job applicants who, in his opinion, are not qualified to perform the classification of work required.

4. If, within one week following the placing of a job order by the contractor with the State Employment Service, the State Employment Service is unable to refer any qualified job applicants to the contractor, or less than the number requested, the State Employment Service will forward a certificate to the contractor indicating the unavailability of applicants. Such certificate shall be made a part of the contractor's permanent project records. Upon receipt of this certificate, the contractor may employ persons who do not normally reside in the labor area to fill positions covered by the certificate, notwithstanding the provisions of subparagraph (1c) above.

5. The provisions of 23 CFR 633.207(e) allow the contracting agency to provide a contractual preference for the use of mineral resource materials native to the Appalachian region.

6. The contractor shall include the provisions of Sections 1 through 4 of this Attachment A in every subcontract for work which is, or reasonably may be, done as on-site work.

FEDERAL AID PROVISIONS

December 1980

NOTICE OF REQUIREMENT FOR AFFIRMATIVE ACTION TO ENSURE EQUAL EMPLOYMENT OPPORTUNITY (EXECUTIVE ORDER 11246)

1. The Offeror's or Bidders attention is called to the "Equal Opportunity Clause" and the Standard Federal Equal Employment Opportunity Construction Contract Specifications" set forth therein.
2. The goals and timetables for minority and female participation, expressed in percentage terms for the Contractor's aggregate workforce in each trade on all construction work in the covered area, are as follows:
3. Construction contractors which are participating in an approved Hometown Plan (see 41 CFR 60-4.5) are required to comply with the goals of the Hometown Plan with regard to construction work they perform in the area covered by the Hometown Plan. With regard to all their covered construction work, such contractors are required to comply with the following goals:

Goals for Female participation for each trade

AREA COVERED

Goals for women apply nationwide

GOALS AND TIMETABLES

Goals

Timetable	(Percent)
From April 1, 1978 until March 31, 1979	3.1
From April 1, 1979 until March 31, 1980	5.1
From April 1, 1980 until March 31, 1981	6.9

Goals for Minority Participation for Each Trade

C o u n t y G o a l (P e r c e n t) C o u n t y G o a l (P e r c e n t)

Adair	4	Linn	4
Andrew	3.2	Livingston	10
Atchison	10	McDonald	2.3
Audrain	4	Macon	4
Barry	2.3	Madison	11.4
Barton	2.3	Maries	11.4
Bates	10	Marion	3.1
Benton	10	Mercer	10
Bollinger	11.4	Miller	4
Boone	6.3	Mississippi	11.4
Buchanan	3.2	Moniteau	4
Butler	11.4	Monroe	4
Caldwell	10	Montgomery	11.4
Callaway	4	Morgan	4
Camden	4	New Madrid	26.5
Cape Girardeau	11.4	Newton	2.3
Carroll	10	Nodaway	10

Carter	11.4	Oregon	2.3
Cass	12.7	Osage	4
Cedar	2.3	Ozark	2.3
Chariton	4	Pemiscot	26.5
Christian	2	Perry	11.4
Clark	3.4	Pettis	10
Clay	12.7	Phelps	11.4
Clinton	10	Pike	3.1
Cole	4	Platte	12.7
Cooper	4	Polk	2.3
Crawford	11.4	Pulaski	2.3
Dade	2.3	Putnam	4
Dallas	2.3	Ralls	3.1
Daviess	10	Randolph	4
DeKalb	10	Ray	12.7
Dent	11.4	Reynolds	11.4
Douglas	2.3	Ripley	11.4
Dunklin	26.5	St. Charles	14.7
Franklin	14.7	St. Clair	2.3
Gasconade	11.4	St. Francois	11.4
Gentry	10	Ste. Genevieve	11.4
Greene	2	St. Louis City	14.7
Grundy	10	St. Louis County	14.7
Harrison	10	Saline	10
Henry	10	Schuylar	4
Hickory	2.3	Scotland	4
Holt	10	Scott	11.4
Howard	4	Shannon	2.3
Howell	2.3	Shelby	4
Iron	11.4	Stoddard	11.4
Jackson	12.7	Stone	2.3
Jasper	2.3	Sullivan	4
Jefferson	14.7	Taney	2.3
Johnson	10	Texas	2.3
Knox	4	Vernon	2.3
Laclede	2.3	Warren	11.4
Lafayette	10	Washington	11.4
Lawrence	2.3	Wayne	11.4
Lewis	3.1	Webster	2.3
Lincoln	11.4	Worth	10
		Wright	2.3

These goals are applicable to all of the contractor's construction work (whether or not is Federal or federally assisted) performed in the covered area. If the contractor performs construction work in a geographical area located outside of the covered area, it shall apply the goals established for such geographical area where the work is actually performed. With regard to this second area, the contractor also is subject to the goals for both its federally involved and nonfederally involved construction.

The Contractor's compliance with the Executive Order and the regulations in 41 CFR Part 60-4 shall be based on Its Implementation of the Equal Opportunity Clause, specific affirmative action obligations required by the specifications set forth in 41 CFR 60-4.3(a), and its effort to meet the goals. The hours of minority and female employment and training must be substantially uniform throughout the length of the contract, and in each trade, and the Contractor shall make a good faith effort to employ minorities and women evenly on each of its projects. The transfer of minority, or female employees or trainees from Contractor to Contractor or from

project to project for the sole purpose of meeting the Contractor's goals shall be a violation of the contract, the Executive Order and the regulations in 41 CFR Part 60-4. Compliance with the goals will be measured against the total work hours performed.

4. The Contractor shall provide written notification to the Director of the Office of Federal Contract Compliance Programs within 10 working days of award of any construction subcontract in excess of \$10,000 at any tier for construction work under the contract resulting from this solicitation. The notification shall list the name, address and telephone number of the subcontractor; employer identification number; estimated dollar amount of the subcontract; estimated starting and completion dates of the subcontract; and the geographical area in which the subcontract is to be performed.
5. As used in this Notice, and in the contract resulting from this solicitation, the "covered area" of the county, route and limits described in the proposal for the work.

July 1986

STANDARD FEDERAL EQUAL EMPLOYMENT OPPORTUNITY CONSTRUCTION
CONTRACT SPECIFICATIONS (EXECUTIVE ORDER 11246)

1. As used in these specifications:

- a. "Covered area" means the geographical area described in the solicitation which this contract resulted.
- b. "Director" mean Director, Office of Federal Contract Compliance Programs, United States Department of labor, or any person to who the Director delegates authority;
- c. "Employer Identification Number" means the Federal Social Security number used on the Employer's quarterly Federal Tax Return, U.S. Treasury Department Form 941;
- d. "Minority" includes;
 - (i) Black (all persons having origins in any of the Black African racial groups not of Hispanic origin);
 - (ii) Hispanic (all persons of Mexican, Puerto Rican, Cuban, Central or South American or other Spanish Culture or origin, regardless of race);
 - (iii) Asian and pacific islander (all persons having origins in any of the original peoples of the Far East, southeast Asia, the Indian Subcontinent, or the Pacific Islands; and
 - (iv) American Indian or Alaskan Native (all persons having origins in any of the original peoples of North American and maintain identifiable affiliations through membership and participation or community identifications.

2. Whenever the Contractor, or any Subcontractor at any tier, subcontractors a portion of the work involving any construction trade, it shall physically include in each subcontract in excess of \$10,000 the provisions of these specifications and the Notice which contains the applicable goals for minority and female participation and which is set forth in the solicitations from which this contract resulted.

3. If the Contract is participating (pursuant to 41 CFR 60-4.5) in a Hometown Plan approved by the U.S. Department of Labor in the covered area either individually or through the association, its affirmative action obligations on all work in the Plan area (including goals and timetables) shall be in accordance with the Plan for those trades which have unions participating in the Plan. Contractors must be able to demonstrate their participation in and compliance with the provisions of any such Hometown Plan. Each Contractor or Subcontractor participating in an approved Plan is individually required to comply with its obligation under the EEO clause, and to make a good faith effort to achieve each goal under the Plan in each trade in which it has employees. The overall good faith performance by other Contractors or Subcontractors toward a goal in an

approved Plan does not excuse any covered Contractor's or Subcontractors' failure to take good faith efforts to achieve the Plan goals and timetables.

4. The Contractor shall implement the specific affirmative action standards provided in paragraphs 7a through 7p of these specifications. The goals set forth in the solicitation from which this contract resulted are expressed as percentages of the total hours of employment and training of minority and female utilization the Contractor should reasonably be able to achieve in each construction trade in which it has employees in the covered area. Covered Construction contractors performing construction work in geographical areas where they do not have a Federal or federally assisted construction contract shall apply the minority and female goals established for the geographical area where the work is being performed. Goals are published periodically in the Federal Register in notice form, and such notices may be obtained from any Office of Federal Contract Compliance Programs office or from Federal procurement contracting officers. The Contractor is expected to make substantially uniform progress toward its goals in each craft during the period specified.
5. Neither the provisions of any collective bargaining agreement, nor the failure by a union with who the Contractor has a collective bargaining agreement, to refer either minorities or women shall excuse the Contractor's obligations under these specifications, Executive Order 11246, or the regulations promulgated pursuant thereto.
6. In order for the nonworking training hours or apprentices and trainees to be counted in meeting the goal, such apprentices and trainees must be employed by the Contractor during the period, and the Contractor must have made a commitment to employ the apprentices and trainees at the completion of their training, subject to the availability of employment opportunities. Trainees must be trained pursuant to training programs approved by the U.S. Department of Labor.
7. The contractor shall take specific affirmative actions to ensure equal employment opportunity. The evaluation of the Contractor's compliance with these specifications shall be used its effort to achieve maximum results from its actions. The Contractor shall document these efforts fully, and shall implement affirmative action steps at least as extensive as the following:
 - a. Ensure and maintain a working environment free of harassment, intimidation, and coercion at all sites, and all facilities at which the Contractor's employees are assigned to work. The Contractor shall specifically ensure that all foremen, superintendents, and other on-site supervisory personnel are aware of and carry out the Contractor's obligation to maintain such a working environment, with specific attention to minority or female individuals working at such sites or in such facilities.
 - b. Establish and maintain a current list of minority and female recruitment sources, provide written notification to minority and female recruitment sources and to community organizations when the Contractor or its unions have employment opportunities available, and maintain a record of the organizations' responses.
 - c. Maintain a current file of the names, addresses and telephone numbers of each minority and female off-the-street applicant and minority or female referral from a union, a recruitment source or community organization and what action was taken with respect to each such individual. If such individual was sent to the union hiring hall for referral and was not referred back to the Contractor by the union or, if referred not employed by the contractor, this shall be documented in the file with the reason therefore, along with whatever additional actions the Contractor may have taken.
 - d. Provide immediate written notification to the Director when the union or unions with which the Contractor has as collective bargaining agreement has not referred to the contractor a minority person or woman sent by the Contractor, or when the Contractor has other information that the union referral process has impeded the Contractor's efforts to meet its obligations.

- e. Develop on-the-job training opportunities and/or participate in training programs for the area which expressly include minorities and women, including upgrading programs and apprenticeship and trainee programs relevant of the contractor's employment needs, especially those programs funded or approved by the Department of Labor. The contractor shall provide notice of these programs to the sources compiled under 7b above.
 - f. Disseminate the Contractor's EEO policy by providing notice of the policy to unions and training programs and requesting their cooperation in assisting the Contractor in meeting its EEO obligations; by including it in any policy manual and collective bargaining agreement by publicizing it in the company newspaper, annual report, etc., by specific review of the policy with all management personnel and with all minority and female employees at least one a year; and by posting the company EEO policy on bulletin boards accessible to all employees at each location where construction work is performed.
 - g. Review, at least annually, the company's EEO policy and affirmative action obligations under these specifications with all employees having any responsibility for hiring, assignment, layoff, termination or other employment decisions including specific review of these items with on-site supervisory personnel such as superintendents, General foreman, etc., prior to the initiation of construction work at any job site. A written record shall be made and maintained identifying the time and place of these meetings, person attending, subject matter discussed, and the disposition of the subject matter.
 - h. Disseminate the Contractor's EEO policy externally by including it in any advertising in the news media, specifically including minority and female news media and providing written notification to and discussing the contractor's EEO policy with other Contractors and Subcontractors with who the Contractor does or anticipates doing business.
 - i. Direct is a recruitment effort, both oral and written, to minority female and community organizations, to schools with minority and female students and to minority and female recruitment and training organizations serving the Contractor's recruitment area and employment needs. Not later than one month prior to the date for the acceptance or applicants for apprenticeship or other training by any recruitment source, the Contractor shall send written notification to organizations such as the above, describing the openings, screening procedures, and test to be used in the selection process.
 - j. Encourage present minority and female employees to recruit other minority persons and women and, where reasonable, provide after school, summer vacations employment to minority and female youth both on the site and in other areas or contractor's workforce.
 - k. Validate all tests and other selection requirements where there is an obligation to do so under 41 CFR Part 60-3.
 - l. Conduct, at least annually, an inventory and evaluation at least of all minority and female personnel for promotional opportunities and encourage these employees to seek or to prepare for, through appropriate training, etc. such opportunities.
 - m. Ensure that seniority practices, job classifications, work assignments and other personnel practices, do not have a discriminatory effect by continually monitoring all personnel and employment related activities to ensure that the EEO policy and the Contractor's obligation under these specifications are being carried out.
 - n. Ensure that all facilities and company activities are non-segregated except that separate or single-user toilet and necessary changing facilities shall be provided to assure privacy between the sexes.
 - o. Document and maintain a record of all solicitations or offers for subcontracts from minority and female construction contractors and suppliers, including circulation of solicitations to minority and female contractor associations and other business associations.
 - p. Conduct a review, at least annually, of all supervisors' adherence to and performance under the Contractor's EEO policies and affirmative action obligations.
8. Contractors are encouraged to participate in voluntary associations which assist in fulfilling one or more of

their affirmative action obligations (7a through 7p). The efforts of a contractor association, joint contractor union, contractor community, or other similar group of which the contractor is a member and participant, may be asserted as fulfilling anyone or more of its obligations under 7a through 7p of these specifications provided that the contractor actively participates in the group, makes every effort to assure that the group has a positive impact on the employment of minorities and women in the industry, ensures that the concrete benefits of the program are reflected in the contractor's minority and female workforce participation, makes a good faith effort to meet its individual goals and timetables, and can provide access to documentation which demonstrates the effectiveness of actions taken on behalf of the contractor. The obligation to comply, however, is the Contractor's and failure of such a group to fulfill an obligation shall not be a defense for the Contractor's noncompliance.

9. A single goal for minorities and a separate single goal for women have been established to provide equal employment opportunity and to take affirmative action for all minority groups, both male and female, and all women, both minority and non-minority. Consequently, the group is employed in a substantially disparate manner (for example, even though the Contractor has achieved its goals for women generally, the Contractor may be in violation of the executive order if a specific minority group of women is underutilized).
10. The Contractor shall not use the goals and timetables or affirmative action standards to discriminate against any person because of race, color, religion, sex, or national origin.
11. The Contractor shall not enter into any Subcontract with any person or firm debarred from Government contract pursuant to Executive Order 11246.
12. The Contractor shall carry out such sanctions and penalties for violation of these specifications and of the Equal Opportunity Clause, including suspension, termination and cancellation of existing subcontracts as may be imposed or ordered pursuant to Executive Order 11246, as amended, and its implementing regulations, by the Office of Federal Contract Compliance Programs. Any Contractor who fails to carry out such sanctions and penalties shall be in violation of these specifications and Executive Order 11246, as amended.
13. The Contractor, in fulfilling its obligations under these specifications, shall implement specific affirmative action steps, at least as extensive as those standards prescribed in paragraph 7 of these specifications, so as to achieve maximum results from its efforts to ensure equal employment opportunity. If the Contractor fails to comply with the requirements of the Executive Order, the implementing regulations, or these specifications, the Direct shall proceed in accordance with 41 CFR 60-4.8.
14. The Contractor shall designate a responsible official to monitor all employment related activity to ensure that the company EEO policy is being carried out to submit reports relating to the provisions hereof as may be required by the Government and to keep records. Records shall at least include for each employee the name, address, telephone numbers, construction trade, union affiliation if any, employee identification number when assigned, social security number, race, sex, status, (e.g. mechanic, apprentice, trainee, helper, or laborer), dates of changes in status, hours worked per week in the indicated trade, rate of pay, and locations at which the work was performed. Records shall be maintained in an easily understandable and retrievable form; however, to the degree that existing records satisfy this requirement, contractors shall not be required to maintain separate records.
15. Nothing herein provided shall be constructed as a limitation upon the application of other laws which establish different standard of compliance or upon the application of requirements for the hiring of local or other area residents (e.g. those under the Public Works Employment Action of 1977 and the Community Development Block Grant Program).

OPERATING POLICY STATEMENT

The contractor shall accept as his operating policy the following statement, or one of equal coverage, which is designed to further the provision of equal employment opportunity to all persons without regard to their race, color, religion,

sex, or national origin, and to promote the full realization of equal employment opportunity through a positive continuing program.

“It is the policy of this company to assure that applicants are employed, and that employees are treated during employment without regard to their race, religion, sex, color, or national origin. Such action shall include: employment, upgrading, demotion, or transfer, recruitment or recruitment advertising; layoff or termination; rates of pay or other forms of compensation; and selection for training, including apprenticeship, pre-apprenticeship, and/or on-the-job training.”

SUPPLEMENTAL REPORTING REQUIREMENTS

- A. The Contractor will keep such records as are necessary to determine compliance with the contractor’s equal employment opportunity obligations. The records kept by the contractor will be designed to indicate the number of minority and non-minority group members and women employed in each work classification on the project.
- B. All such records must be retained for a period of three years following completion of the contract work and shall be available at reasonable times and places for inspection by authorized representatives of the State Highway Agency and the Federal Highway Administration.
- C. The contractor and each covered subcontractor will submit to the State Highway Agency, for the month of July, for the duration of the project, a report (Form PR-1391) “Federal-Aid Highway Construction Contractors Annual EEO Report”, indicating the number of minority, women and non-minority group employees currently engaged in each work classification required by the contract work.

NONDISCRIMINATION IN EMPLOYMENT July 1990

The following provisions are added by the State to the Required Contract Provisions of Federal-Aid Contracts.

The contractor is advised that the exemptions referred to in the Required Contract Provisions, Federal-Aid contracts under Section II, Nondiscrimination, Paragraph 3g, with respect to contracts and subcontracts, are substantial and are to be found in Chapter 60, Office of Federal Contract Compliance, Equal Employment Opportunity, Department of Labor (33 Federal Register 7804-7812, May 28, 1968, effective July 1, 1968, Chapter 60, Title 41, Code of Federal Regulations), by which contracts and subcontracts of \$10,000 or less and certain contracts and subcontracts for indefinite quantities are exempt.

The two pertinent exemption clauses are as

follows: 60-1.5 Exemptions

- (a) General – (1) Transactions of \$10,000 or under. Contracts and Subcontractors not exceeding \$10,000, other than Government bills of lading, and other than contract and subcontracts with depositories of Federal funds in any amount and with financial institutions which are issuing and paying agents for U.S. savings bonds and savings notes, are exempt from the requirements of the equal opportunity clause. In determining the applicability of this exemption to any federally assisted construction contract, or subcontract thereunder, the amount of such contract or subcontract rather than the amount of the Federal financial assistance shall govern. No agency, contractor, or subcontractor shall procure supplies or services in a manner so as to avoid applicability of the equal opportunity clause: Provided, that where a contractor has contracts or subcontracts with the Government in any 12-month period which have an aggregate total value (or can reasonably be expected to have an aggregate total value) exceeding \$10,000, the \$10,000 or under exemption does not apply, and the contracts are subject to the order and the regulation issued pursuant thereto regardless of whether any single contracts exceeds \$10,000.

APPLICABLE STATE WAGE RATES

Missouri

Division of Labor Standards

WAGE AND HOUR SECTION

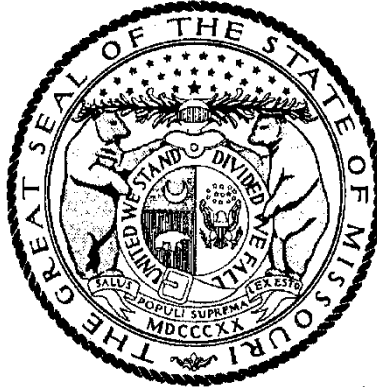

MICHAEL L. PARSON, Governor

Annual Wage Order No. 31

Section 100
ST. LOUIS COUNTY

In accordance with Section 290.262 RSMo 2000, within thirty (30) days after a certified copy of this Annual Wage Order has been filed with the Secretary of State as indicated below, any person who may be affected by this Annual Wage Order may object by filing an objection in triplicate with the Labor and Industrial Relations Commission, P.O. Box 599, Jefferson City, MO 65102-0599. Such objections must set forth in writing the specific grounds of objection. Each objection shall certify that a copy has been furnished to the Division of Labor Standards, P.O. Box 449, Jefferson City, MO 65102-0449 pursuant to 8 CSR 20-5.010(1). A certified copy of the Annual Wage Order has been filed with the Secretary of State of Missouri.

Original Signed by _____

Todd Smith, Director
Division of Labor Standards

Filed With Secretary of State: _____ **March 8, 2024**

Last Date Objections May Be Filed: **April 8, 2024**

Prepared by Missouri Department of Labor and Industrial Relations

Building Construction Rates for
ST. LOUIS County

Section 100

OCCUPATIONAL TITLE	**Prevailing Hourly Rate
Asbestos Worker	\$67.80
Boilermaker	\$42.03*
Bricklayer-Stone Mason	\$62.04
Carpenter	\$64.31
Lather	
Linoleum Layer	
Millwright	
Pile Driver	
Cement Mason	\$57.86
Plasterer	
Communication Technician	\$62.59
Electrician (Inside Wireman)	\$75.44
Electrician Outside Lineman	\$42.03*
Lineman Operator	
Lineman - Tree Trimmer	
Groundman	
Groundman - Tree Trimmer	
Elevator Constructor	\$42.03*
Glazier	\$66.98
Ironworker	\$70.24
Laborer	\$53.79
General Laborer	
First Semi-Skilled	
Second Semi-Skilled	
Mason	\$57.61
Marble Mason	
Marble Finisher	
Terrazzo Worker	
Terrazzo Finisher	
Tile Setter	
Tile Finisher	
Operating Engineer	\$69.55
Group I	
Group II	
Group III	
Group III-A	
Group IV	
Group V	
Painter	\$54.63
Plumber	\$77.88
Pipe Fitter	
Roofer	\$57.83
Sheet Metal Worker	\$73.78
Sprinkler Fitter	\$82.11
Truck Driver	\$42.03*
Truck Control Service Driver	
Group I	
Group II	
Group III	
Group IV	

*The Division of Labor Standards received fewer than 1,000 reportable hours for this occupational title. The public works contracting minimum wage is established for this occupational title using data provided by Missouri Economic Research and Information Center.

**The Prevailing Hourly Rate includes any applicable fringe benefit amounts for each occupational title as defined in RSMo Section 290.210.

Heavy Construction Rates for
ST. LOUIS County

Section 100

OCCUPATIONAL TITLE	**Prevailing Hourly Rate
Carpenter	\$64.02
Millwright	
Pile Driver	
Electrician (Outside Lineman)	\$78.52
Lineman Operator	
Lineman - Tree Trimmer	
Groundman	
Groundman - Tree Trimmer	
Laborer	\$54.45
General Laborer	
Skilled Laborer	
Operating Engineer	\$70.83
Group I	
Group II	
Group III	
Group IV	
Truck Driver	\$50.95
Truck Control Service Driver	
Group I	
Group II	
Group III	
Group IV	

Use Heavy Construction Rates on Highway and Heavy construction in accordance with the classifications of construction work established in 8 CSR 30-3.040(3).

Use Building Construction Rates on Building construction in accordance with the classifications of construction work established in 8 CSR 30-3.040(2).

If a worker is performing work on a heavy construction project within an occupational title that is not listed on the Heavy Construction Rate Sheet, use the rate for that occupational title as shown on the Building Construction Rate Sheet.

*The Division of Labor Standards received fewer than 1,000 reportable hours for this occupational title. Public works contracting minimum wage is established for this occupational title using data provided by Missouri Economic Research and Information Center.

**The Prevailing Hourly Rate includes any applicable fringe benefit amounts for each occupational title.

OVERTIME and HOLIDAYS

OVERTIME

For all work performed on a Sunday or a holiday, not less than twice (2x) the prevailing hourly rate of wages for work of a similar character in the locality in which the work is performed or the public works contracting minimum wage, whichever is applicable, shall be paid to all workers employed by or on behalf of any public body engaged in the construction of public works, exclusive of maintenance work.

For all overtime work performed, not less than one and one-half (1½) the prevailing hourly rate of wages for work of a similar character in the locality in which the work is performed or the public works contracting minimum wage, whichever is applicable, shall be paid to all workers employed by or on behalf of any public body engaged in the construction of public works, exclusive of maintenance work or contractual obligation. For purposes of this subdivision, "**overtime work**" shall include work that exceeds ten hours in one day and work in excess of forty hours in one calendar week; and

A thirty-minute lunch period on each calendar day shall be allowed for each worker on a public works project, provided that such time shall not be considered as time worked.

HOLIDAYS

January first;
The last Monday in May;
July fourth;
The first Monday in September;
November eleventh;
The fourth Thursday in November; and
December twenty-fifth;

If any holiday falls on a Sunday, the following Monday shall be considered a holiday.

APPLICABLE FEDERAL WAGE RATES

"General Decision Number: M020240001 08/09/2024

Superseded General Decision Number: M020230001

State: Missouri

Construction Types: Heavy and Highway

Counties: Missouri Statewide.

HEAVY AND HIGHWAY CONSTRUCTION PROJECTS

Note: Contracts subject to the Davis-Bacon Act are generally required to pay at least the applicable minimum wage rate required under Executive Order 14026 or Executive Order 13658. Please note that these Executive Orders apply to covered contracts entered into by the federal government that are subject to the Davis-Bacon Act itself, but do not apply to contracts subject only to the Davis-Bacon Related Acts, including those set forth at 29 CFR 5.1(a)(1).

If the contract is entered into on or after January 30, 2022, or the contract is renewed or extended (e.g., an option is exercised) on or after January 30, 2022:	. Executive Order 14026 generally applies to the contract. . The contractor must pay all covered workers at least \$17.20 per hour (or the applicable wage rate listed on this wage determination, if it is higher) for all hours spent performing on the contract in 2024.
If the contract was awarded on or between January 1, 2015 and January 29, 2022, and the contract is not renewed or extended on or after January 30, 2022:	. Executive Order 13658 generally applies to the contract. . The contractor must pay all covered workers at least \$12.90 per hour (or the applicable wage rate listed on this wage determination, if it is higher) for all hours spent performing on that contract in 2024.

The applicable Executive Order minimum wage rate will be adjusted annually. If this contract is covered by one of the Executive Orders and a classification considered necessary for performance of work on the contract does not appear on this wage determination, the contractor must still submit a conformance request.

Additional information on contractor requirements and worker protections under the Executive Orders is available at <http://www.dol.gov/whd/govcontracts>.

Modification Number	Publication Date
0	01/05/2024
1	01/19/2024
2	02/23/2024
3	03/08/2024
4	04/19/2024
5	05/24/2024
6	07/05/2024
7	07/12/2024
8	08/02/2024
9	08/09/2024

CARP0002-002 05/01/2023

ST. LOUIS COUNTY AND CITY

	Rates	Fringes
Carpenters.....	\$ 40.34	21.25

CARP0005-006 05/01/2023

CASS (Richards-Gebauer AFB ONLY), CLAY, JACKSON, PLATTE AND RAY COUNTIES

	Rates	Fringes
Carpenters:		
CARPENTERS & LATHERS.....	\$ 43.28	21.25
MILLWRIGHTS & PILEDRIVERS...	\$ 43.28	21.25

 CARP0011-001 05/01/2023

	Rates	Fringes
Carpenter and Piledriver		
ADAIR, AUDRAIN (West of Hwy 19), BOONE, CALLAWAY, CHARITON, COLE, COOPER, HOWARD, KNOX, LINN, MACON, MILLER, MONITEAU, MONROE, OSAGE, PUTNAM, RANDOLPH, SCHUYLER, SHELBY AND SULLIVAN COUNTIES.....	\$ 34.31	21.25
ATCHISON, ANDREW, BATES, CALDWELL, CARROLL, DAVIESS, DEKALB, GENTRY, GRUNDY, HARRISON, HENRY, HOLT, LIVINGSTON, MERCER, NODAWAY, ST. CLAIR, SALINE AND WORTH COUNTIES.....	\$ 32.64	21.25
AUDRAIN (East of Hwy.19), RALLS, MARION, LEWIS, CLARK AND SCOTLAND COUNTIES..	\$ 34.31	21.25
BARRY, BARTON, CAMDEN, CEDAR, CHRISTIAN, DADE, DALLAS, DOUGLAS, GREENE, HICKORY, JASPER, LACLEDE, LAWRENCE, MCDONALD, NEWTON, OZARK, POLK, STONE, TANEY, VERNON, WEBSTER AND WRIGHT COUNTIES..	\$ 32.20	21.25
BENTON, MORGAN AND PETTIS...	\$ 32.69	21.25
BOLLINGER, BUTLER, CAPE GIRARDEAU, DUNKLIN, MISSISSIPPI, NEW MADRID, PEMISCOT, PERRY, STE. GENEVIEVE, SCOTT, STODDARD AND WAYNE COUNTIES.....	\$ 34.15	21.25
BUCHANAN, CLINTON, JOHNSON AND LAFAYETTE COUNTIES.....	\$ 33.43	21.25
CARTER, HOWELL, OREGON AND RIPLEY COUNTIES.....	\$ 32.99	21.25
CRAWFORD, DENT, GASCONADE, IRON, MADISON, MARIES, MONTGOMERY, PHELPS, PULASKI, REYNOLDS, SHANNON AND TEXAS COUNTIES.....	\$ 34.14	21.25
FRANKLIN COUNTY.....	\$ 37.93	21.25
JEFFERSON AND ST. CHARLES COUNTIES.....	\$ 40.34	21.25
LINCOLN COUNTY.....	\$ 36.21	21.25
PIKE, ST. FRANCOIS AND WASHINGTON COUNTIES.....	\$ 35.01	21.25
WARREN COUNTY.....	\$ 36.69	21.25

 * ELEC0001-002 06/02/2024

BOLLINGER, BUTLER, CAPE GIRARDEAU, CARTER, DUNKLIN, FRANKLIN, IRON, JEFFERSON, LINCOLN, MADISON, MISSISSIPPI, NEW MADRID, PEMISCOT, PERRY, REYNOLDS, RIPLEY, ST. CHARLES, ST. FRANCOIS, ST. LOUIS (City and County), STE. GENEVIEVE, SCOTT, STODDARD, WARREN, WASHINGTON AND WAYNE COUNTIES

	Rates	Fringes
Electricians.....	\$ 47.04	18.196

 ELEC0002-001 09/04/2022

ADAIR, AUDRAIN, BOONE, CALLAWAY, CAMDEN, CARTER, CHARITON, CLARK, COLE, COOPER, CRAWFORD, DENT, FRANKLIN, GASCONADE, HOWARD, HOWELL, IRON, JEFFERSON, KNOX, LEWIS, LINCON, LINN, MACON, MARIES, MARION, MILLER, MONITEAU, MONROE, MONTGOMERY, MORGAN, OREGON, OSAGE, PERRY, PHELPS, PIKE, PULASKI, PUTNAM, RALLS, RANDOLPH, REYNOLDS, RIPLEY, ST. CHARLES, ST. FRANCOIS, ST. LOUIS (City and County), STE. GENEVIEVE, SCHUYLER, SCOTLAND, SHANNON, SHELBY, SULLIVAN, TEXAS, WARREN AND WASHINGTON COUNTIES

	Rates	Fringes
Line Construction:		
Equipment Operator.....	\$ 44.16	23.14
Groundman & Truck Driver....	\$ 33.74	19.34
Lineman & Cable Splicer.....	\$ 51.45	25.81

ELEC0053-004 01/01/2024

	Rates	Fringes
Line Construction: (ANDREW, ATCHINSON, BARRY, BARTON, BUCHANAN, CALDWELL, CEDAR, CHRISTIAN, CLINTON, DADE, DALLAS, DAVIES,, DEKALB, DOUGLAS, GENTRY, GREENE, GRUNDY, HARRISON, HICKORY, HOLT, JASPER, LACLEDE, LAWRENCE, LIVINGSTON, MCDONALD, MERCER, NEWTON, NODAWAY, OZARK, POLK, ST. CLAIR, STONE, TANEY, VERNON, WEBSTER, WORTH AND WRIGHT COUNTIES)		
Groundman Powderman.....	\$ 35.71	1.5%+9.04
Groundman.....	\$ 32.32	1.5%+18.25
Lineman Operator.....	\$ 48.73	1.5%+23.33
Lineman.....	\$ 54.02	1.5%+25.08

Line Construction; (BATES, BENTON, CARROLL, CASS, CLAY, HENRY, JACKSON, JOHNSON, LAFAYETTE, PETTIS, PLATTE, RAY AND SALINE COUNTIES)		
Groundman Powderman.....	\$ 33.58	18.34
Groundman.....	\$ 31.33	17.60
Lineman Operator.....	\$ 45.60	22.48
Lineman.....	\$ 50.31	24.11

ELEC0095-001 06/01/2024

BARRY, BARTON, CEDAR, DADE, JASPER, LAWRENCE, MCDONALD, NEWTON, ST CLAIR, AND VERNON COUNTIES

	Rates	Fringes
Electricians:		
Cable Splicers.....	\$ 25.40	12.19
Electricians.....	\$ 31.09	8%+18.04

ELEC0124-007 08/28/2023

BATES, BENTON, CARROLL, CASS, CLAY, COOPER, HENRY, JACKSON, JOHNSON, LAFAYETTE, MORGAN, PETTIS, PLATTE, RAY AND SALINE COUNTIES:

	Rates	Fringes
Electricians.....	\$ 47.37	25.89

ELEC0257-003 03/01/2024

AUDRAIN (Except Cuivre Township), BOONE, CALLAWAY, CAMDEN, CHARITON, COLE, CRAWFORD, DENT, GASCONADE, HOWARD, MARIES, MILLER, MONITEAU, OSAGE, PHELPS AND RANDOLPH COUNTIES

	Rates	Fringes
Electricians:		
Cable Splicers.....	\$ 30.42	16.085
Electricians.....	\$ 38.50	17.515

ELEC0350-002 12/01/2023

ADAIR, AUDRAIN (East of Highway 19), CLARK, KNOX, LEWIS, LINN, MACON, MARION, MONROE, MONTGOMERY, PIKE, PUTNAM, RALLS, SCHUYLER, SCOTLAND, SHELBY AND SULLIVAN COUNTIES

	Rates	Fringes
Electricians.....	\$ 36.60	20.96

ELEC0453-001 09/01/2023

Rates Fringes

Electricians:

CHRISITAN, DALLAS,		
DOUGLAS, GREENE, HICKORY,		
HOWELL, LACLEDE, OREGON,		
OZARK, POLK, SHANNON,		
WEBSTER and WRIGHT COUNTIES..	\$ 36.08	17.91
PULASKI and TEXAS COUNTIES..	\$ 36.08	17.91
STONE and TANEY COUNTIES....	\$ 26.62	17.11

ELEC0545-003 06/01/2023

ANDREW, BUCHANAN, CLINTON, DEKALB, ATCHISON, HOLT, MERCER,
GENTRY, HARRISON, DAVIESS, GRUNDY, WORTH, LIVINGSTON, NODAWAY,
AND CALDWELL COUNTIES

Rates Fringes

Electricians:.....	\$ 36.75	20.40
--------------------	----------	-------

ELEC0702-004 01/01/2024

BOLLINGER, BUTLER, CAPE GIRARDEAU, DUNKLIN, MADISON,
MISSISSIPPI, NEW MADRID, PEMISCOT, SCOTT, STODDARD AND WAYNE
COUNTIES

Rates Fringes

Line Construction:

Groundman - Class A.....	\$ 36.89	30%+8.60
Groundman-Equipment Operator Class II (all other equipment).....	\$ 44.92	30%+8.60
Heavy-Equipment Operator Class I (all crawler type equipment D-4 and larger)...	\$ 50.37	30%+8.60
Lineman.....	\$ 63.30	30%+8.60

ENGI0101-001 05/01/2020

ANDREW, ATCHISON, BATES, BENTON, BUCHANAN, CALDWELL, CARROLL,
CHARITON, CLINTON, COOPER, DAVIESS, DEKALB, GENTRY, GRUNDY,
HARRISON, HENRY, HOLT, HOWARD, JOHNSON, LAFAYETTE, LINN,
LIVINGSTON, MERCER, NODAWAY, PETTIS, SALINE, SULLIVAN AND WORTH
COUNTIES

Rates Fringes

Power equipment operators:

GROUP 1.....	\$ 34.73	18.20
GROUP 2.....	\$ 34.33	18.20
GROUP 3.....	\$ 32.33	18.20

POWER EQUIPMENT OPERATORS CLASSIFICATIONS

GROUP 1: Asphalt roller operator, finish; asphalt paver and
spreader; asphalt plant operator; auto grader or trimmer or
sub-grader; backhoe; blade operator (all types); boilers -
2; booster pump on dredge; bulldozer operator; boring
machine (truck or crane mounted); clamshell operator;
concrete mixer paver; concrete plant operator; concrete
pump operator; crane operator; derrick or derrick trucks;
ditching machine; dragline operator; dredge engineman;
dredge operator; drill cat with compressor mounted
(self-contained) or similar type self-propelled rotary
drill (not air tract); drilling or boring machine
(rotary-self-propelled); finishing machine operator;
greaser; high loader-fork lift-skid loader (all types);
hoisting engineer (2 active drums); locomotive operator
(standard guage); mechanics and welders (field and plants);
mucking machine operator; pile drive operator; pitman crane
or boom truck (all types); push cat; quad track; scraper
operators (all types); shovel operator; sideboom cats; side
discharge spreader; skimmer scoop operators; slip form
paver operator (CMI, Rex, Gomeco or equal); la tourneau
rooter (all tiller types); tow boat operator; truck crane;
wood and log chippers (all types).

GROUP 2: A-frame truck operator; articulated dump truck;
back filler operator; boilers (1); chip spreader; churn
drill operator; compressor; concrete mixer operator, skip
loader; concrete saws (self-propelled); conveyor operator;

crusher operator; distributor operator; elevating grader operator; farm tractor (all attachments); fireman rig; float operator; form grade operator; hoisting engine (one drum); maintenance operator; multiple compactor; pavement breaker, self-propelled hydra-hammer (or similar type); paymill operator; power shield; pumps; roller operator (with or without blades); screening and washing plant; self-propelled street broom or sweeper; siphons and jets; straw blower; stump cutting machine; siphons and jets; tank car heater operator (combination boiler and booster); welding machine; vibrating machine operator (not hand held); welding machine.

- GROUP 3: (a) Oiler;
 (b) Oiler driver
 (c) Mechanic.

HOURLY PREMIUMS:

THE FOLLOWING CLASSIFICATIONS SHALL RECEIVE (\$.25) ABOVE GROUP 1 RATE: Dragline operator - 3 yds. & over; shovel 3 yds. & over; clamshell 3 yds. & over; Crane, rigs or piledrivers, 100' of boom or over (incl. jib.), hoist - each additional active drum over 2 drums

THE FOLLOWING CLASSIFICATIONS SHALL RECEIVE (\$.50) ABOVE GROUP 1 RATE: Tandem scoop operator; crane, rigs or piledrivers 150' to 200' of boom (incl. jib.)

THE FOLLOWING CLASSIFICATIONS SHALL RECEIVE (\$.75) ABOVE GROUP 1 RATE: Crane rigs, or piledrivers 200 ft. of boom or over (including jib.)

 ENGI0101-005 04/01/2022

CASS, CLAY, JACKSON, PLATTE AND RAY COUNTIES

	Rates	Fringes
Power equipment operators:		
GROUP 1.....	\$ 38.42	20.44
GROUP 2.....	\$ 37.38	20.44
GROUP 3.....	\$ 32.91	20.44
GROUP 4.....	\$ 36.26	20.44

POWER EQUIPMENT OPERATORS CLASSIFICATIONS

GROUP 1: Asphalt roller operator, finish; asphalt paver and spreader; asphalt plant operator; auto grader or trimmer or sub-grader; backhoe; blade operator (all types); boilers-2; booster pump on dredge; boring machine (truck or crane mounted); bulldozer operator; clamshell operator; concrete cleaning decontamination machine operator; concrete mixer paver; concrete plant operator; concrete pump operator; crane operator; derrick or derrick trucks; ditching machine; dragline operator; dredge engineman; dredge operator; drillcat with compressor mounted (self-contained) or similar type self propelled rotary drill (not air tract); drilling or boring machine (rotary - self-propelled); finishing machine operator; greaser; heavy equipment robotics operator/mechanic; horizontal directional drill operator; horizontal directional drill locator; loader-forklift - skid loader (all types); hoisting engineer (2 active drums); locomotive operator (standard guage); master environmental maintenance mechanic; mechanics and welders (field and plants); mucking machine operator; piledrive operator; pitman crane or boom truck (all types); push cat; quad-track; scraper operators (all types); shovel operator; side discharge spreader; sideboom cats; skimmer scoop operator; slip-form paver (CMI, REX, Gomaco or equal); la tourneau rooter (all tiller types); tow boat operator; truck crane; ultra high perssure waterjet cutting tool system operator/mechanic; vacuum blasting machine operator/mechanic; wood and log chippers (all types)

GROUP 2: ""A"" Frame truck operator; back filler operator; boilers (1); chip spreader; churn drill operator; concrete mixer operator, skip loader; concrete saws (self-propelled); conveyor operator; crusher operator; distributor operator; elevating grader operator; farm tractor (all attachments); fireman rig; float operator; form grader operator; hoisting engine (1 drum); maintenance operator; multiple compactor; pavement breaker, self-propelled hydra- hammer (or similar type); power shield; paymill operator; pumps; siphons and jets; stump cutting machine; tank car heater operator (combination

boiler and booster); compressor; roller operator (with or without blades); screening and washing plant; self-propelled street broom or sweeper; straw blower; tank car heater operator (combination boiler and booster); vibrating machine operator (not hand held)

GROUP 3: Oilers

GROUP 4: Oiler Driver (All Types)

FOOTNOTE:

HOURLY PREMIUMS FOLLOWING CLASSIFICATIONS SHALL RECEIVE (\$1.00) ABOVE GROUP 1 RATE:
 Clamshells - 3 yd. capacity or over; Cranes or rigs, 80 ft. of boom or over (including jib); Draglines, 3 yd. capacity or over;
 Piledrivers 80 ft. of boom or over (including jib);
 Shovels & backhoes, 3 yd. capacity or over.

 ENGI0101-022 05/01/2019

BARRY, BARTON, CAMDEN, CEDAR, CHRISTIAN, DADE, DALLAS, DOUGLAS, GREENE, HICKORY, JASPER, LACLEDE, LAWRENCE, MCDONALD, NEWTON, OZARK, POLK, ST. CLAIR, STONE, TANEY, VERNON, WEBSTER AND WRIGHT COUNTIES and CITY OF SPRINGFIELD

	Rates	Fringes
Power equipment operators:		
GROUP 1.....	\$ 31.72	14.88
GROUP 2.....	\$ 31.37	14.88
GROUP 3.....	\$ 31.17	14.88
GROUP 4.....	\$ 29.12	14.88

POWER EQUIPMENT OPERATORS CLASSIFICATIONS

GROUP 1: Asphalt finishing machine & trench widening spreader; asphalt plant console operator; autograder; automatic slipform paver; backhoe; blade operator - all types; boat operator - tow; boilers-2; central mix concrete plant operator; clamshell operator; concrete mixer paver; crane operator; derrick or derrick trucks; ditching machine; dozer operator; dragline operator; dredge booster pump; dredge engineman; dredge operator; drill cat with compressor mounted on cat; drilling or boring machine rotary self-propelled; highloader; hoisting engine - 2 active drums; launch hammer wheel; locomotive operator; - standard guage; mechanic and welders; mucking machine; off-road trucks; piledriver operator; pitman crane operator; push cat operator; quad trac; scoop operator - all types; shovel operator; sideboom cats; skimmer scoop operators; trenching machine operator; truck crane.

GROUP 2: A-frame; asphalt hot-mix silo; asphalt plant fireman (drum or boiler); asphalt plant man; asphalt plant man; asphalt plant mixer operator; asphalt roller operator; backfiller operator; barber-greene loader; boat operator (bridges and dams); chip spreader; concrete mixer operator - skip loader; concrete plant operator; concrete pump operator; crusher operator; dredge oiler; elevating grader operator; fork lift; greaser-fleet; hoisting engine - 1; locomotive operator - narrow gauge; multiple compactor; pavement breaker; powerbroom - self-propelled; power shield; rooter; side discharge concrete spreader; slip form finishing machine; stumpcutter machine; throttle man; tractor operator (over 50 h.p.); winch truck.

GROUP 3: Boilers - 1; chip spreader (front man); churn drill operator; clef plane operator; concrete saw operator (self-propelled); curb finishing machine; distributor operator; finishing machine operator; flex plane operator; float operator; form grader operator; pugmill operator; roller operator, other than high type asphalt; screening & washing plant operator; siphons & jets; sub-grading machine operator; spreader box operator, self-propelled (not asphalt); tank car heater operator (combination boiler & booster); tractor operator (50 h.p. or less); Ulmac, Ulric or similar spreader; vibrating machine operator, not hand;

GROUP 4: Grade checker; Oiler; Oiler-Driver

HOURLY PREMIUMS:

The following classifications shall receive \$.25 above GROUP 1 rate:

Clamshells - 3 yds. or over; Cranes - Rigs or Piledrivers, 100 ft. of boom or over (including jib); Draglines - 3 yds. or over; Hoists - each additional active drum over 2 drums; Shovels - 3 yds. or over;

The following classifications shall receive \$.50 above GROUP 1 rate:
 Tandem scoop operator; Cranes - Rigs or Piledrivers, 150 ft. to 200 ft. of boom (including jib); Tandem scoop.

The following classifications shall receive \$.75 above GROUP 1 rate:
 Cranes - Rigs or Piledrivers, 200 ft. of boom or over (including jib.).

 ENGI0513-004 05/03/2023

FRANKLIN, JEFFERSON, LINCOLN, ST CHARLES, AND WARREN COUNTIES

	Rates	Fringes
Power equipment operators:		
GROUP 1.....	\$ 41.01	29.63
GROUP 2.....	\$ 41.01	29.63
GROUP 3.....	\$ 39.71	29.63
GROUP 4.....	\$ 39.26	29.63

POWER EQUIPMENT OPERATORS CLASSIFICATIONS

GROUP 1: Backhoe, Cable; Backhoe, Hydraulic (2 cu yds bucket and under regardless of attachment, one oiler for 2 or 3, two oilers for 4 through 6); Backhoe, Hydraulic over 2 cu yds; Cableway; Crane, Crawler or Truck; Crane, Hydraulic - Truck or Cruiser mounted, 16 tons and over; Crane, Locomotive; crane with boom including jib over 100 ft from pin to pin; Crane using rock socket tool; Derrick, Steam; Derrick Car and Derrick Boat; Dragline, 7 cu yds and over; Dredge; Gradall, Crawler or tire mounted; Locomotive, Gas, Steam & other powers; Pile Driver, Land or Floating; Scoop, Skimmer; Shovel, Power (Electric, Gas, Steam or other powers); Shovel, Power (7 cu yds and over); Switch Boat; Whirley; Air Tugger with air compressor; Anchor Placing Barge; Asphalt Spreader; Athey Force Feeder Loader, self-propelled; Backfilling Machine; Boat Operator - Push Boat or Tow Boat (job site); Boiler, High Pressure Breaking in Period; Boom Truck, Placing or Erecting; Boring Machine, Footing Foundation; Bullfloat; Cherry Picker; Combination Concrete Hoist and Mixer (such as Mixermobile); Compressor, Two 125 CFM and under; Compressor, Two through Four over 125 CFM; Compressor when operator runs throttle; Concrete Breaker (Truck or Tractor mounted); Concrete Pump (such as Pumpcrete machine); Concrete Saw (self-propelled); Concrete Spreader; Conveyor, Large (not selfpropelled) hoisting or moving brick and concrete into, or into and on floor level, one or both; Crane, Climbing (such as Linden); Crane, Hydraulic - Rough Terrain, self-propelled; Crane, Hydraulic - Truck or Cruiser mounted - under 16 tons; Drilling machine - Self-powered, used for earth or rock drilling or boring (wagon drills and any hand drills obtaining power from other sources including concrete breakers, jackhammers and Barco equipment no engineer required); Elevating Grader; Engine Man, Dredge; Excavator or Powerbelt Machine; Finishing Machine, self-propelled oscillating screed; Forklift; Generators, Two through Six 30 KW or over; Grader, Road with power blade; Greaser; Highlift; Hoist, Concrete and Brick (Brick cages or concrete skips operating or on tower, Towermobile, or similar equipment); Hoist, Three or more drums in use; Hoist, Stack; Hydro-Hammer; Lad-A-Vator, hoisting brick or concrete; Loading Machine such as Barber-Greene; Mechanic on job site

GROUP 2: Air Tugger with plant air; Boiler (for power or heating shell of building or temporary enclosures in connection with construction work); Boiler, Temporary; Compressor, One over 125 CFM; Compressor, truck mounted; Conveyor, Large (not self-propelled); Conveyor, Large (not self-propelled) moving brick and concrete (distributing) on floor level; Curb Finishing Machine; Ditch Paving Machine; Elevator (outside); Endless Chain Hoist; Fireman (as required); Form Grader; Hoist, One Drum regardless of size (except brick or concrete); Lad-A-Vator, other hoisting; Manlift; Mixer, Asphalt, over 8 cu ft capacity; Mixer, one bag capacity or less; Mixer, without side loader, two bag capacity or more; Mixer, with side loader, regardless of size, not Paver; Mud Jack (where mud jack is used in conjunction with an air compressor, operator shall

be paid \$.55 per hour in addition to his basic hourly rate for covering both operations); Pug Mill operator; Pump, Sump - self powered, automatic controlled over 2"; Scissor Lift (used for hoisting); Skid Steer Loader; Sweeper, Street; Tractor, small wheel type 50 HP and under with grader blade and similar equipment; Welding Machine, One over 400 amp; Winch, operating from truck

GROUP 3: Boat operator - outboard motor, job site; Conveyors (such as Con-Vay-It) regardless of how used; Elevator (inside); Heater operator, 2 through 6; Sweeper, Floor

GROUP 4: Crane type

HOURLY PREMIUMS:

Backhoe, Hydraulic 2 cu yds or less without oiler - \$2.00;
 Crane, climbing (such as Linden) - \$.50;
 Crane, Pile Driving and Extracting - \$.50
 Crane with boom (including job) over 100 ft from pin to pin - add \$.01 per foot to maximum of \$4.00);
 Crane, using rock socket tool - \$.50;
 Derrick, diesel, gas or electric hoisting material and erecting steel (150 ft or more above ground) - \$.50;
 Dragline, 7 cu yds and over - \$.50;
 Hoist, Three or more drums in use - \$.50;
 Scoop, Tandem - \$.50;
 Shovel, Power - 7 cu yds and over - \$.50;
 Tractor, Tandem Crawler - \$.50;
 Tunnel, man assigned to work in tunnel or tunnel shaft - \$.50;
 Wrecking, when machines are working on second floor or higher - \$.50

 ENGI0513-006 05/01/2022

ADAIR, AUDRAIN, BOLLINGER, BOONE, BUTLER, CALLAWAY, CAPE GIRARDEAU, CARTER, CLARK, COLE, CRAWFORD, DENT, DUNKLIN, GASCONADE, HOWELL, IRON, KNOX, LEWIS, MACON, MADISON, MARIES, MARION, MILLER, MISSISSIPPI, MONITEAU, MONROE, MONTGOMERY, MORGAN, NEW MADRID, OREGON, OSAGE, PEMISCOT, PERRY, PHELPS, PIKE, PULASKI, PUTNAM, RALLS, RANDOLPH, REYNOLDS, RIPLEY, ST. FRANCOIS, STE. GENEVIEVE, SCHUYLER, SCOTLAND, SCOTT, SHANNON, SHELBY, STODDARD, TEXAS, WASHINGTON, AND WAYNE COUNTIES

	Rates	Fringes
Power equipment operators:		
GROUP 1.....	\$ 33.24	28.75
GROUP 2.....	\$ 32.89	28.75
GROUP 3.....	\$ 32.69	28.75
GROUP 4.....	\$ 29.04	28.75

POWER EQUIPMENT OPERATORS CLASSIFICATIONS

GROUP 1: Asphalt finishing machine & trench widening spreader, asphalt plant console operator; autograder; automatic slipform paver; back hoe; blade operator - all types; boat operator tow; boiler two; central mix concrete plant operator; clam shell operator; concrete mixer paver; crane operator; derrick or derrick trucks; ditching machine; dozer operator; dragline operator; dredge booster pump; dredge engineman; dredge operator; drill cat with compressor mounted on cat; drilling or boring machine rotary self-propelled; highloader; hoisting engine 2 active drums; launchhammer wheel; locomotive operator standrad guage; mechanics and welders; mucking machine; piledriver operator; pitman crane operator; push cat operator; guad-trac; scoop operator; sideboom cats; skimmer scoop operator; trenching machine operator; truck crane, shovel operator.

GROUP 2: A-Frame; asphalt hot-mix silo; asphalt roller operator asphalt plant fireman (drum or boiler); asphalt plant man; asphalt plant mixer operator; backfiller operator; barber-greene loader; boat operator (bridge & dams); chip spreader; concrete mixer operator skip loader; concrete plant operator; concrete pump operator; dredge oiler; elevating graded operator; fork lift; grease fleet; hoisting engine one; locomotive operator narrow guage; multiple compactor; pavement breaker; powerbroom self-propelled; power shield; rooter; slip-form finishing machine; stumpcutter machine; side discharge concrete spreader; throttleman; tractor operator (over 50 hp); winch

truck; asphalt roller operator; crusher operator.

GROUP 3: Spreader box operator, self-propelled not asphalt; tractor operator (50 h.p. or less); boilers one; chip spreader (front man); churn drill operator; compressor over 105 CFM 2-3 pumps 4" & over; 2-3 light plant 7.5 KWA or any combination thereof; clef plane operator; compressor maintenance operator 2 or 3; concrete saw operator (self-propelled); curb finishing machine; distributor operator; finishing machine operator; flex plane operator; float operator; form grader operator; pugmill operator; riller operator other than high type asphalt; screening & washing plant operator; siphons & jets; subgrading machine operator; tank car heater (combination boiler & booster); ulmac, ulric or similar spreader; vibrating machine operator; hydrobroom.

GROUP 4: Oiler; grout machine; oiler driver; compressor over 105 CFM one; conveyor operator one; maintenance operator; pump 4" & over one.

FOOTNOTE: HOURLY PREMIUMS

Backhoe hydraulic, 2 cu. yds. or under Without oiler - \$2.00
Certified Crane Operator - \$1.50;
Certified Hazardous Material Operator \$1.50;
Crane, climbing (such as Linden) - \$0.50;
Crane, pile driving and extracting - \$0.50;
Crane, with boom (including jib) over 100' from pin to pin add \$0.01 per foot to maximum of \$4.00;
Crane, using rock socket tool - \$0.50;
Derrick, diesel, gas or electric, hoisting material and erecting steel (150' or more above the ground) - \$0.50;
Dragline, 7 cu. yds, and over - \$0.50;
Hoist, three or more drums in use - \$0.50; Scoop, Tandem - \$0.50;
Shovel, power - 7 cu. yds. or more - \$0.50;
Tractor, tandem crawler - \$0.50;
Tunnel, man assigned to work in tunnel or tunnel shaft - \$0.50;
Wrecking, when machine is working on second floor or higher - \$0.50;

ENGI0513-007 05/03/2023

ST. LOUIS CITY AND COUNTY

	Rates	Fringes
Power equipment operators:		
GROUP 1.....	\$ 41.01	29.63
GROUP 2.....	\$ 41.01	29.63
GROUP 3.....	\$ 39.71	29.63
GROUP 4.....	\$ 39.26	29.63

POWER EQUIPMENT OPERATORS CLASSIFICATIONS

GROUP 1: Backhoe, cable or hydraulic; cableway; crane crawler or truck; crane, hydraulic-truck or cruiser mounted 16 tons & over; crane locomotive; derrick, steam; derrick car & derrick boat; dragline; dredge; gradall, crawler or tire mounted; locomotive, gas, steam & other powers; pile driver, land or floating; scoop, skimmer; shovel, power (steam, gas, electric or other powers); switch boat; whirley.

GROUP 2: Air tugger w/air compressor; anchor-placing barge; asphalt spreader; athey force feeder loader (self-propelled); backfilling machine; backhoe-loader; boat operator-push boat or tow boat (job site); boiler, high pressure breaking in period; boom truck, placing or erecting; boring machine, footing foundation; bull- float; cherry picker; combination concrete hoist & mixer (such as mixer mobile); compressor (when operator runs throttle); concrete breaker (truck or tractor mounted); concrete pump, such as pump-crete machine; concrete saw (self-propelled), concrete spreader; conveyor, large (not self-propelled), hoisting or moving brick and concrete into, or into and on floor level, one or both; crane, hydraulic-rough terrain, self-propelled; crane hydraulic-truck or cruiser mounted-under 16 tons; drilling machines, self-powered use for earth or rock drilling or boring (wagon drills nd any hand drills obtaining power from other sources including concrete breakers, jackhammers and barco equipment-no engineer required); elevating grader; engineman, dredge; excavator or powerbelt machine; finishing machine,

self-propelled oscillating screed; forklift; grader, road with power blade; highlift. greaser; hoist, stack, hydro-hammer; loading machine (such as barber-greene); machanic, on job site; mixer, pipe wrapping machines; plant asphalt; plant, concrete producing or ready-mix job site; plant heating-job site; plant mixing-job site; plant power, generating-job site; pumps, two through six self-powered over 2"; pumps, electric submersible, two through six, over 4"; quad-track; roller, asphalt, top or sub-grade; scoop, tractor drawn; spreader box; sub-grader; tie tamper; tractor-crawler, or wheel type with or without power unit, power take-offs and attachments regardless of size; trenching machine; tunnel boring machine; vibrating machine automatic, automatic propelled; welding machines (gasoline or diesel) two through six; well drilling machine

GROUP 3: Conveyor, large (not self-propelled); conveyor, large (not self-propelled) moving brick and concrete distributing) on floor level; mixer two or more mixers of one bag capacity or less; air tuggler w/plant air; boiler, for power or heating on construction projects; boiler, temporary; compressor (mounted on truck; curb finishing machine; ditch paving machine; elevator; endless chain hoist; form grader; hoist, one drum regardless of size; lad-a-vator; manlift; mixer, asphalt, over 8 cu. ft. capacity, without side loader, 2 bag capacity or more; mixer, with side loader, regardless of size; pug mill operator; pump, sump-self-powered, automatic controlled over 2" during use in connection with construction work; sweeper, street; welding machine, one over 400 amp.; winch operating from truck; scissor lift (used for hoisting); tractor, small wheel type 50 h.p. & under with grader blade & similar equipment; Oiler on dredge and on truck crane.

GROUP 4: Boat operator-outboard motor (job site); conveyor (such as con-vay-it) regardless of how used; sweeper, floor

HOURLY PREMIUMS:

Backhoe, hydraulic	
2 cu. yds. or under without oiler	\$2.00
Certified Crane Operator	1.50
Certified Hazardous Material Operator	1.50
Crane, climbing (such as Linden)	.50
Crane, pile driving and extracting	.50
Crane, with boom (including jib) over 100' (from pin to pin) add \$.01 per foot to maximum of	4.00
Crane, using rock socket tool	.50
Derrick, diesel, gas or electric, hoisting material and erecting steel (150' or more above ground)	.50
Dragline, 7 cu. yds. and over	.50
Hoist, three (3) or more drums in use	.50
Scoop, Tandem	.50
Shovel, power - 7 cu. yds. or more	.50
Tractor, tandem crawler	.50
Tunnel, man assigned to work in tunnel or tunnel shaft	.50
Wrecking, when machine is working on second floor or higher	.50

IRON0010-012 04/01/2024

Rates Fringes

Ironworkers:

ANDREW, BARTON, BENTON, CAMDEN, CEDAR, CHARITON, CHRISTIAN, COOPER, DADE, DALLAS, DAVIESS, DE KALB, GENTRY, GREENE, GRUNDY, HARRISON, HICKORY, HOLT, HOWARD, LACLEDE, LINN, LIVINGSTON, MERCER, MONITEAU, MORGAN, NODAWAY, PETTIS, POLK, PUTNAM, RANDLOPH, ST. CLAIR, SULLIVAN, TANEY, VERNON, WEBSTER, WRIGHT and WORTH Counties and portions of ADAIR, BOONE, MACON, MILLER and RANDOLPH Counties.....\$ 35.00	33.56
ATCHISON, BATES, BUCHANAN, CALDWELL, CARROLL, CASS, CLAY, CLINTON, HENRY,	

JACKSON, JOHNSON,
LAFAYETTE, PETTIS, PLATTE,
SALINE, AND RAY COUNTIES....\$ 38.00 33.56

IRON0321-002 08/01/2023

DOUGLAS, HOWELL and OZARK COUNTIES

	Rates	Fringes
Ironworker.....	\$ 27.00	20.96

IRON0396-004 08/02/2023

ST. LOUIS (City and County), ST. CHARLES, JEFFERSON, IRON,
FRANKLIN, LINCOLN, WARREN, WASHINGTON, ST. FRANCOIS, STE.
GENEVIEVE, and REYNOLDS Counties; and portions of MADISON,
PERRY, BOLLINGER, WAYNE, and CARTER Counties

	Rates	Fringes
Ironworker.....	\$ 40.37	30.55

IRON0396-009 08/02/2023

AUDRAIN, CALLAWAY, COLE, CRAWFORD, DENT, GASCONADE, MARIES,
MONTGOMERY, OSAGE, PHELPS, PIKE, PULASKI, TEXAS and WRIGHT
Counties; and portions of BOONE, CAMDEN, DOUGLAS, HOWELL,
LACLEDE, MILLER, MONROE, OREGON, SHANNON and RALLS Counties

	Rates	Fringes
Ironworker.....	\$ 40.37	30.55

IRON0577-005 06/01/2023

ADAIR, CLARK, KNOX, LEWIS, MACON, MARION, MONROE, RALLS,
SCHUYLER, SCOTLAND, AND SHELBY COUNTIES

	Rates	Fringes
Ironworker.....	\$ 31.55	25.05

IRON0584-004 06/01/2023

BARRY, JASPER, LAWRENCE, MCDONALD, NEWTON AND STONE Counties

	Rates	Fringes
Ironworkers:.....	\$ 29.00	16.20

IRON0782-003 08/01/2023

CAPE GIRARDEAU, MISSISSIPPI, NEW MADRID, SCOTT, & STODDARD
Counties; and portions of BOLLINGER, BUTLER, CARTER, DUNKLIN,
MADISON, PEMISCOT, PERRY, RIPLEY, and WAYNE Counties

	Rates	Fringes
Ironworkers: Locks, Dams, Bridges and other major work on the Mississippi and Ohio River only.....	\$ 38.77	29.51
All Other Work.....	\$ 33.47	24.12

LAB00042-003 03/01/2023

ST. LOUIS (City and County)

	Rates	Fringes
LABORER Plumber Laborer.....	\$ 36.65	17.12

LAB00042-005 03/01/2023

ST. LOUIS (City and County)

	Rates	Fringes
LABORER Dynamiter, Powderman.....	\$ 36.65	17.12

Laborers, Flaggers.....	\$ 36.65	17.12
Wrecking.....	\$ 36.65	17.12

LAB00110-005 05/01/2023

Jefferson and Washington Counties

	Rates	Fringes
LABORER (Jefferson County)		
GROUP 1.....	\$ 35.49	15.62
GROUP 2.....	\$ 36.09	15.62
LABORER (Washington County)		
GROUP 1.....	\$ 32.98	15.62
GROUP 2.....	\$ 32.98	15.62

LABORERS CLASSIFICATIONS

GROUP 1 - General laborer-flagman, carpenter tenders; salamander Tenders; Dump Man; Ticket Takers; loading trucks under bins, hoppers, and conveyors; track man; cement handler; dump man on earth fill; georgie buggy man; material batch hopper man; spreader on asphalt machine; material mixer man (except on manholes); coffer dams; riprap pavers rock, block or brick; scaffolds over ten feet not self-supported from ground up; skip man on concrete paving; wire mesh setters on concrete paving; all work in connection with sewer, water, gas, gasoling, oil, drainage pipe, conduit pipe, tile and duct lines and all other pipe lines; power tool operator; all work in connection with hydraulic or general dredging operations; form setters, puddlers (paving only); straw blower nozzle man; asphalt plant platform man; chuck tender; crusher feeder; men handling creosote ties or creosote materials; men working with and handling epoxy material; topper of standing trees; feeder man on wood pulverizers, board and willow mat weavers and cabelee tiers on river work; deck hands; pile dike and revetment work; all laborers working on underground tunnels less than 25 ft. where compressed air is not used; abutement and pier hole men working six (6) ft. or more below ground; men working in coffer dams for bridge piers and footing in the river; barco tamper; jackson or any other similar tamp; cutting torch man; liners, curb, gutters, ditch lines; hot mastic kettlemen; hot tar applicator; hand blade operator; mortar men or brick or block manholes; rubbing concrete, air tool operator under 65 lbs.; caulker and lead man; chain or concrete saw under 15 h.p.; signal Gan; Guard rail and sign erectors.

GROUP 2 - Skilled laborers - Vibrator man; asphalt raker; head pipe layer on sewer work; batterboard man on pipe and ditch work; cliff scalers working from bosun's chairs; scaffolds or platforms on dams or power plants over 10 ft. high; air tool operator over 65 lbs.; stringline man on concrete paving; sandblast man; laser beam man; wagon drill; churn drill; air track drill and all other similar type drills, gunite nozzle man; pressure grout man; screed man on asphalt; concrete saw 15 h.p. and over; grade checker; strigline man on electronic grade control; manhole builder; dynamite man; powder man; welder; tunnel man; waterblaster - 1000 psi or over; asbestos and/or hazardous waste removal and/or disposal

LAB00579-005 05/01/2023

	Rates	Fringes
LABORER (ANDREW, ATCHISON, BUCHANAN, CALDWELL, CLINTON, DAVIESS, DEKALB, GENTRY, GRUNDY, HARRISON, HOLT, LIVINGSTON, MERCER, NODAWAY and WORTH COUNTIES.)		
GROUP 1.....	\$ 29.04	16.59
GROUP 2.....	\$ 29.39	16.59
LABORER (BARRY, BARTON, BATES, BENTON, CAMDEN, CARROLL, CEDAR, CHRISTIAN, DADE, DALLAS, DOUGLAS, GREENE, HENRY, HICKORY, JASPER, JOHNSON, LACLEDE, LAWRENCE, MCDONALD, MORGAN, NEWTON, OZARK, PETTIS, POLK, ST. CLAIR, SALINE, STONE, TANEY, VERNON, WEBSTER and		

WRIGHT COUNTIES)

GROUP 1.....	\$ 28.23	15.60
GROUP 2.....	\$ 28.78	15.60

LABORER (LAFAYETTE COUNTY)

GROUP 1.....	\$ 29.78	15.85
GROUP 2.....	\$ 30.13	15.85

LABORERS CLASSIFICATIONS

GROUP 1: General Laborers - Carpenter tenders; salamander tenders; loading trucks under bins; hoppers & conveyors; track men & all other general laborers; air tool operator; cement handler-bulk or sack; dump man on earth fill; georgie buggy man; material batch hopper man; material mixer man (except on manholes); coffer dams; riprap pavers - rock, block or brick; signal man; scaffolds over ten feet not self-supported from ground up; skipman on concrete paving; wire mesh setters on concrete paving; all work in connection with sewer, water, gas, gasoline, oil drainage pipe, conduit pipe, tile and duct lines and all other pipe lines; power tool operator, all work in connection with hydraulic or general dredging operations; puddlers (paving only); straw blower nozzle man; asphalt plant platform man; chuck tender; crusher feeder; men handling creosote ties or creosote materials; men working with and handling epoxy material or materials (where special protection is required); rubbing concrete; topper of standing trees; batter board man on pipe and ditch work; feeder man on wood pulverizers; board and willow mat weavers and cable tiers on river work; deck hands; pile dike and revetment work; all laborers working on underground tunnels less than 25 feet where compressed air is not used; abutment and pier hole men working six (6) feet or more below ground; men working in coffer dams for bridge piers and footings in the river; ditchliners; pressure groutmen; caulker; chain or concrete saw; cliffscalers working from scaffolds, bosuns' chairs or platforms on dams or power plants over (10) feet above ground; mortarmen on brick or block manholes; toxic and hazardous waste work.

GROUP 2: Skilled Laborers - Head pipe layer on sewer work; laser beam man; Jackson or any other similar tamp; cutting torch man; form setters; liners and stringline men on concrete paving, curb, gutters; hot mastic kettleman; hot tar applicator; sandblasting and gunite nozzle men; air tool operator in tunnels; screed man on asphalt machine; asphalt raker; barco tamper; churn drills; air track drills and all similar drills; vibrator man; stringline man for electronic grade control; manhole builders-brick or block; dynamite and powder men; grade checker.

LAB00660-004 05/01/2023

Clark, Knox, Lewis, Marion, Pike, Ralls, Scotland, Shelby Counties

Rates Fringes

LABORER

GROUP 1.....	\$ 32.98	15.62
GROUP 2.....	\$ 32.98	15.62

LABORERS CLASSIFICATIONS

GROUP 1 - General laborer-flagman, carpenter tenders; salamander Tenders; Dump Man; Ticket Takers; loading trucks under bins, hoppers, and conveyors; track man; cement handler; dump man on earth fill; georgie buggy man; material batch hopper man; spreader on asphalt machine; material mixer man (except on manholes); coffer dams; riprap pavers rock, block or brick; scaffolds over ten feet not self-supported from ground up; skip man on concrete paving; wire mesh setters on concrete paving; all work in connection with sewer, water, gas, gasoling, oil, drainage pipe, conduit pipe, tile and duct lines and all other pipe lines; power tool operator; all work in connection with hydraulic or general dredging operations; form setters, puddlers (paving only); straw blower nozzle man; asphalt plant platform man; chuck tender; crusher feeder; men handling creosote ties or creosote materials; men working with and handling epoxy material; topper of standing trees; feeder man on wood pulverizers, board and willow mat weavers and cable tiers on river work; deck hands; pile dike and revetment work; all laborers working on underground tunnels less than 25 ft. where compressed air

is not used; abutement and pier hole men working six (6) ft. or more below ground; men working in coffer dams for bridge piers and footing in the river; barco tamper; jackson or any other similar tamp; cutting torch man; liners, curb, gutters, ditch lines; hot mastic kettlemen; hot tar applicator; hand blade operator; mortar men or brick or block manholes; rubbing concrete, air tool operator under 65 lbs.; caulker and lead man; chain or concrete saw under 15 h.p.; signal Gan; Guard rail and sign erectors.

GROUP 2 - Skilled laborers - Vibrator man; asphalt raker; head pipe layer on sewer work; batterboard man on pipe and ditch work; cliff scalers working from bosun's chairs; scaffolds or platforms on dams or power plants over 10 ft. high; air tool operator over 65 lbs.; stringline man on concrete paving; sandblast man; laser beam man; wagon drill; churn drill; air track drill and all other similar type drills, gunite nozzle man; pressure grout man; screed man on asphalt; concrete saw 15 h.p. and over; grade checker; strigline man on electronic grade control; manhole builder; dynamite man; powder man; welder; tunnel man; waterblaster - 1000 psi or over; asbestos and/or hazardous waste removal and/or disposal

LAB00660-006 03/01/2023

Lincoln, Montgomery, St Charles and Warren Counties

	Rates	Fringes
LABORER (Common or General).....	\$ 36.91	15.62

LAB00662-001 05/01/2023

Callaway, Cole, Miller and Moniteau Counties

	Rates	Fringes
LABORER		
GROUP 1.....	\$ 32.98	15.62
GROUP 2.....	\$ 32.98	15.62

LABORERS CLASSIFICATIONS

GROUP 1 - General laborer-flagman, carpenter tenders; salamander Tenders; Dump Man; Ticket Takers; loading trucks under bins, hoppers, and conveyors; track man; cement handler; dump man on earth fill; georgie buggie man; material batch hopper man; spreader on asphalt machine; material mixer man (except on manholes); coffer dams; riprap pavers rock, block or brick; scaffolds over ten feet not self-supported from ground up; skip man on concrete paving; wire mesh setters on concrete paving; all work in connection with sewer, water, gas, gasoling, oil, drainage pipe, conduit pipe, tile and duct lines and all other pipe lines; power tool operator; all work in connection with hydraulic or general dredging operations; form setters, puddlers (paving only); straw blower nozzle man; asphalt plant platform man; chuck tender; crusher feeder; men handling creosote ties or creosote materials; men working with and handling epoxy material; topper of standing trees; feeder man on wood pulverizers, board and willow mat weavers and cabelee tiers on river work; deck hands; pile dike and revetment work; all laborers working on underground tunnels less than 25 ft. where compressed air is not used; abutement and pier hole men working six (6) ft. or more below ground; men working in coffer dams for bridge piers and footing in the river; barco tamper; jackson or any other similar tamp; cutting torch man; liners, curb, gutters, ditch lines; hot mastic kettlemen; hot tar applicator; hand blade operator; mortar men or brick or block manholes; rubbing concrete, air tool operator under 65 lbs.; caulker and lead man; chain or concrete saw under 15 h.p.; signal Gan; Guard rail and sign erectors.

GROUP 2 - Skilled laborers - Vibrator man; asphalt raker; head pipe layer on sewer work; batterboard man on pipe and ditch work; cliff scalers working from bosun's chairs; scaffolds or platforms on dams or power plants over 10 ft. high; air tool operator over 65 lbs.; stringline man on concrete paving; sandblast man; laser beam man; wagon drill; churn drill; air track drill and all other similar type drills, gunite nozzle man; pressure grout man; screed man on asphalt; concrete saw 15 h.p. and over; grade

checker; strigline man on electronic grade control; manhole builder; dynamite man; powder man; welder; tunnel man; waterblaster - 1000 psi or over; asbestos and/or hazardous waste removal and/or disposal

LAB00663-002 04/01/2024

CASS, CLAY, JACKSON, PLATTE AND RAY COUNTIES

	Rates	Fringes
LABORER		
GROUP 1.....	\$ 35.24	15.57
GROUP 2.....	\$ 36.45	15.57

LABORERS CLASSIFICATIONS

GROUP 1: General laborers, Carpenter tenders, salamander tenders, loading trucks under bins, hoppers and conveyors, track men and all other general laborers, air tool operator, cement handler (bulk or sack), chain or concrete saw, deck hands, dump man on earth fill, Georgie Buggies man, material batch hopper man, scale man, material mixer man (except on manholes), coffer dams, abutments and pier hole men working below ground, riprap pavers rock, black or brick, signal man, scaffolds over ten feet not self-supported from ground up, skipman on concrete paving, wire mesh setters on concrete paving, all work in connection with sewer,water, gas, gasoling, oil, drainage pipe, conduit pipe, tile and duct lines and all other pipelines, power tool operator, all work in connection with hydraulic or general dredging operations, straw blower nozzle man, asphalt plant platform man, chuck tender, crusher feeder, men handling creosote ties on creosote materials, men working with and handling epoxy material or materials (where special protection is required), topper of standing trees, batter board man on pipe and ditch work, feeder man on wood pulverizers, board and willow mat weavers and cable tiers on river work, deck hands, pile dike and revetment work, all laborers working on underground tunnels less than 25 feet where compressed air is not used, abutment and pier hole men working six (6) feet or more below ground, men working in coffer dams for bridge piers and footings in the river, ditchliners, pressure groutmen, caulker and chain or concrete saw, cliffscalers working from scaffolds, bosuns' chairs or platforms on dams or power plants over (10) feet above ground, mortarmen on brick or block manholes, signal man.

GROUP 2: Skilled Laborer - spreader or screed man on asphalt machine, asphalt raker, grade checker, vibrator man, concrete saw over 5 hp., laser beam man, barco tamper, jackson or any other similar tamp, wagon driller, churn drills, air track drills and other similar drills, cutting torch man, form setters, liners and stringline men on concrete paving, curb, gutters and etc., hot mastic kettleman, hot tar applicator, hand blade operators, mortar men on brick or block manholes, sand blasting and gunnite nozzle men, rubbing concrete, air tool operator in tunnels, head pipe layer on sewer work, manhole builder (brick or block), dynamite and powder men.

LAB00840-011 05/01/2023

Crawford, Dent, Franklin, Gasconade, Howell, Maries, Oregon, Osage, Phelps, Pulaski, Shannon and Texas Counties

	Rates	Fringes
LABORER (Crawford, Dent, Gasconade, Howell, Maries, Oregon, Osage, Phelps, Pulaski, Shannon and Texas Counties)		
GROUP 1.....	\$ 32.98	15.62
GROUP 2.....	\$ 32.98	15.62
LABORER (Franklin County)		
GROUP 1.....	\$ 35.44	15.62
GROUP 2.....	\$ 36.04	15.62

LABORERS CLASSIFICATIONS

GROUP 1 - General laborer-flagman, carpenter tenders; salamander Tenders; Dump Man; Ticket Takers; loading trucks

under bins, hoppers, and conveyors; track man; cement handler; dump man on earth fill; georgie buggy man; material batch hopper man; spreader on asphalt machine; material mixer man (except on manholes); coffer dams; riprap pavers rock, block or brick; scaffolds over ten feet not self-supported from ground up; skip man on concrete paving; wire mesh setters on concrete paving; all work in connection with sewer, water, gas, gasoling, oil, drainage pipe, conduit pipe, tile and duct lines and all other pipe lines; power tool operator; all work in connection with hydraulic or general dredging operations; form setters, puddlers (paving only); straw blower nozzleman; asphalt plant platform man; chuck tender; crusher feeder; men handling creosote ties or creosote materials; men working with and handling epoxy material; topper of standing trees; feeder man on wood pulverizers, board and willow mat weavers and cabelee tiers on river work; deck hands; pile dike and revetment work; all laborers working on underground tunnels less than 25 ft. where compressed air is not used; abutement and pier hole men working six (6) ft. or more below ground; men working in coffer dams for bridge piers and footing in the river; barco tamper; jackson or any other similar tamp; cutting torch man; liners, curb, gutters, ditch lines; hot mastic kettlemen; hot tar applicator; hand blade operator; mortar men or brick or block manholes; rubbing concrete, air tool operator under 65 lbs.; caulker and lead man; chain or concrete saw under 15 h.p.; signal Gan; Guard rail and sign erectors.

GROUP 2 - Skilled laborers - Vibrator man; asphalt raker; head pipe layer on sewer work; batterboard man on pipe and ditch work; cliff scalers working from bosun's chairs; scaffolds or platforms on dams or power plants over 10 ft. high; air tool operator over 65 lbs.; stringline man on concrete paving; sandblast man; laser beam man; wagon drill; churn drill; air track drill and all other similar type drills, gunite nozzle man; pressure grout man; screed man on asphalt; concrete saw 15 h.p. and over; grade checker; strigline man on electronic grade control; manhole builder; dynamite man; powder man; welder; tunnel man; waterblaster - 1000 psi or over; asbestos and/or hazardous waste removal and/or disposal

 LAB00955-012 05/01/2023

Adair, Audrain, Boone, Chariton, Cooper, Howard, Linn, Macon, Monroe, Putnam, Randolph, Schuyler and Sullivan Counties

Rates Fringes

LABORER		
GROUP 1.....	\$ 32.98	15.62
GROUP 2.....	\$ 32.98	15.62

LABORERS CLASSIFICATIONS

GROUP 1 - General laborer-flagman, carpenter tenders; salamander Tenders; Dump Man; Ticket Takers; loading trucks under bins, hoppers, and conveyors; track man; cement handler; dump man on earth fill; georgie buggy man; material batch hopper man; spreader on asphalt machine; material mixer man (except on manholes); coffer dams; riprap pavers rock, block or brick; scaffolds over ten feet not self-supported from ground up; skip man on concrete paving; wire mesh setters on concrete paving; all work in connection with sewer, water, gas, gasoling, oil, drainage pipe, conduit pipe, tile and duct lines and all other pipe lines; power tool operator; all work in connection with hydraulic or general dredging operations; form setters, puddlers (paving only); straw blower nozzleman; asphalt plant platform man; chuck tender; crusher feeder; men handling creosote ties or creosote materials; men working with and handling epoxy material; topper of standing trees; feeder man on wood pulverizers, board and willow mat weavers and cabelee tiers on river work; deck hands; pile dike and revetment work; all laborers working on underground tunnels less than 25 ft. where compressed air is not used; abutement and pier hole men working six (6) ft. or more below ground; men working in coffer dams for bridge piers and footing in the river; barco tamper; jackson or any other similar tamp; cutting torch man; liners, curb, gutters, ditch lines; hot mastic kettlemen; hot tar applicator; hand blade operator; mortar men or brick or block manholes; rubbing concrete, air tool

operator under 65 lbs.; caulker and lead man; chain or concrete saw under 15 h.p.; signal Gan; Guard rail and sign erectors.

GROUP 2 - Skilled laborers - Vibrator man; asphalt raker; head pipe layer on sewer work; batterboard man on pipe and ditch work; cliff scalers working from bosun's chairs; scaffolds or platforms on dams or power plants over 10 ft. high; air tool operator over 65 lbs.; stringline man on concrete paving; sandblast man; laser beam man; wagon drill; churn drill; air track drill and all other similar type drills, gunite nozzle man; pressure grout man; screed man on asphalt; concrete saw 15 h.p. and over; grade checker; strigline man on electronic grade control; manhole builder; dynamite man; powder man; welder; tunnel man; waterblaster - 1000 psi or over; asbestos and/or hazardous waste removal and/or disposal

LAB01104-005 05/01/2023

Bollinger, Butler, Cape Girardeau, Carter, Dunklin, Iron, Madison, Mississippi, New Madrid, Pemiscot, Perry, Reynolds, Ripley, Scott, St Francois, Ste Genevieve, Stoddard and Wayne Counties

	Rates	Fringes
LABORER		
GROUP 1.....	\$ 32.98	15.62
GROUP 2.....	\$ 32.98	15.62

LABORERS CLASSIFICATIONS

GROUP 1 - General laborer-flagman, carpenter tenders; salamander Tenders; Dump Man; Ticket Takers; loading trucks under bins, hoppers, and conveyors; track man; cement handler; dump man on earth fill; georgie buggy man; material batch hopper man; spreader on asphalt machine; material mixer man (except on manholes); coffer dams; riprap pavers rock, block or brick; scaffolds over ten feet not self-supported from ground up; skip man on concrete paving; wire mesh setters on concrete paving; all work in connection with sewer, water, gas, gasoling, oil, drainage pipe, conduit pipe, tile and duct lines and all other pipe lines; power tool operator; all work in connection with hydraulic or general dredging operations; form setters, puddlers (paving only); straw blower nozzle man; asphalt plant platform man; chuck tender; crusher feeder; men handling creosote ties or creosote materials; men working with and handling epoxy material; topper of standing trees; feeder man on wood pulverizers, board and willow mat weavers and cable ties on river work; deck hands; pile dike and revetment work; all laborers working on underground tunnels less than 25 ft. where compressed air is not used; abutement and pier hole men working six (6) ft. or more below ground; men working in coffer dams for bridge piers and footing in the river; barco tamper; jackson or any other similar tamp; cutting torch man; liners, curb, gutters, ditch lines; hot mastic kettlemen; hot tar applicator; hand blade operator; mortar men or brick or block manholes; rubbing concrete, air tool operator under 65 lbs.; caulker and lead man; chain or concrete saw under 15 h.p.; signal Gan; Guard rail and sign erectors.

GROUP 2 - Skilled laborers - Vibrator man; asphalt raker; head pipe layer on sewer work; batterboard man on pipe and ditch work; cliff scalers working from bosun's chairs; scaffolds or platforms on dams or power plants over 10 ft. high; air tool operator over 65 lbs.; stringline man on concrete paving; sandblast man; laser beam man; wagon drill; churn drill; air track drill and all other similar type drills, gunite nozzle man; pressure grout man; screed man on asphalt; concrete saw 15 h.p. and over; grade checker; strigline man on electronic grade control; manhole builder; dynamite man; powder man; welder; tunnel man; waterblaster - 1000 psi or over; asbestos and/or hazardous waste removal and/or disposal

PAIN002-002 09/01/2007

CLARK, FRANKLIN, JEFFERSON, LEWIS, LINCOLN, MARION, PIKE, RALLS, ST. CHARLES, ST. LOUIS (CITY & COUNTY), AND WARREN COUNTIES

	Rates	Fringes
Painters:		
Brush and Roller; Taper.....	\$ 28.61	10.24
High work over 60 feet.....	\$ 29.11	10.24
Lead Abatement.....	\$ 29.36	10.24
Pressure Roller; High work under 60 ft.....	\$ 28.86	10.24
Spray & Abrasive Blasting; Water Blasting (Over 5000 PSI).....	\$ 30.61	10.24
Taper (Ames Tools & Bazooka).....	\$ 30.21	10.24

PAIN002-006 04/01/2023

ADAIR, AUDRAIN, BOONE, CALLAWAY, CHARITON, COLE, GASCONADE,
HOWARD, KNOX, LINN, MACON, MONROE, MONTGOMERY, OSAGE, PUTNAM,
RANDOLPH, SCHUYLER, SCOTLAND, SHELBY AND SULLIVAN COUNTIES and
the City of Booneville.

	Rates	Fringes
Painters:		
Bridges, Dams, Locks or Powerhouses.....	\$ 28.49	15.03
Brush and Roll; Taping, Paperhanging.....	\$ 26.49	15.03
Epoxy or Any Two Part Coating; Sandblasting; Stage or other Aerial Work - Platforms over 50 feet high; Lead Abatement.....	\$ 27.49	15.03
Spray; Structural Steel (over 50 feet).....	\$ 27.49	15.03
Tapers using Ames or Comparable Tools.....	\$ 27.24	15.03

PAIN003-004 04/01/2019

CASS, CLAY, CLINTON, JACKSON, JOHNSON, LAFAYETTE, PLATTE & RAY
COUNTIES

	Rates	Fringes
Painters:		
Bridgeman; Lead Abatement; Sandblast; Storage Bin & Tanks.....	\$ 33.41	17.76
Brush & Roller.....	\$ 30.54	17.76
Drywall.....	\$ 31.74	17.76
Paper Hanger.....	\$ 31.04	17.76
Stageman; Beltman; Steelman; Elevator Shaft; Bazooka, Boxes and Power Sander; Sprayman; Dipping... Steeplejack.....	\$ 32.41 \$ 36.98	17.76 17.76

PAIN003-011 04/01/2019

BATES, BENTON, CALDWELL, CARROLL, COOPER, DAVIESS, GRUNDY,
HARRISON, HENRY, LIVINGSTON, MERCER, MONITEAU, MORGAN, PETTIS &
SALINE COUNTIES

	Rates	Fringes
Painters:		
Bridgeman; Lead Abatement; Sandblast; Storage Bin & Tanks.....	\$ 26.73	17.76
Brush & Roller.....	\$ 24.43	17.76
Drywall.....	\$ 25.39	17.76
Paper Hanger.....	\$ 24.83	17.76
Stageman; Beltman; Steelman; Elevator Shaft; Bazooka, Boxes and Power Sander; Sprayman; Dipping... Steeplejack.....	\$ 26.35 \$ 29.58	17.76 17.76

PAIN1185-008 04/01/2024

CAMDEN, CRAWFORD, DENT, LACLEDE, MARIES, MILLER, PHELPS,

PULASKI AND TEXAS COUNTIES

	Rates	Fringes
Painters:		
Brush and Roller.....	\$ 32.25	16.86
Floor Work.....	\$ 33.25	16.86
Lead Abatement.....	\$ 33.25	16.86
Spray.....	\$ 33.25	16.86
Structural Steel, Sandblasting and All Tank Work.....	\$ 34.25	16.86
Taping, Paperhanging.....	\$ 33.25	16.86

PAIN1292-002 09/01/2022

BOLLINGER, BUTLER, CAPE GIRARDEAU, CARTER, DUNKLIN,
MISSISSIPPI, NEW MADRID, OREGON, PEMISCOT, PERRY, REYNOLDS,
RIPLEY, SCOTT, SHANNON, STODDARD and WAYNE COUNTIES

	Rates	Fringes
Painters:		
Bridges, Stacks & Tanks.....	\$ 33.93	15.36
Brush & Roller.....	\$ 29.58	15.36
Spray & Abrasive Blasting; Waterblasting (over 5000 PSI).....	\$ 31.58	15.36

Height Rates (All Areas):
Over 60 ft. \$0.50 per hour.
Under 60 ft. \$0.25 per hour.

PAIN1292-003 09/01/2022

IRON, MADISON, ST. FRANCOIS, STE. GENEVIEVE and WASHINGTON
COUNTIES

	Rates	Fringes
Painters:		
Bridges, Stacks & Tanks.....	\$ 33.93	15.36
Brush & Roller.....	\$ 29.58	15.36
Spray & Abrasive Blasting; Waterblasting (Over 5000 PSI).....	\$ 31.58	15.36

Height Rates (All Areas):
Over 60 ft. \$0.50 per hour
Under 60 ft. \$0.25 per hour.

PAIN2012-001 04/01/2023

ANDREW, ATCHISON, BUCHANAN, DE KALB, GENTRY, HOLT, NODAWAY &
WORTH COUNTIES

	Rates	Fringes
Painters:		
Brush & Roller.....	\$ 34.22	19.13
Sandblaster.....	\$ 38.46	19.13
Steeplejack.....	\$ 42.03	19.13

PAIN2015-001 04/01/2012

BARRY, BARTON, CEDAR, CHRISTIAN, DADE, DALLAS, DOUGLAS, GREENE,
HICKORY, HOWELL, JASPER, LAWRENCE, MCDONALD, NEWTON, OZARK,
POLK, ST. CLAIR, STONE, TANEY, VERNON, WEBSTER, and WRIGHT
COUNTIES

	Rates	Fringes
Painters:		
Finisher.....	\$ 20.18	11.33
Painter.....	\$ 19.75	11.76
Sandblaster, High Man, Spray Man, Vinyl Hanger, Tool Operator.....	\$ 21.18	11.33

PLAS0518-006 03/01/2023

BARRY, BARTON, CEDAR, CHRISTIAN, DADE, DALLAS, DOUGLAS, GREENE, HICKORY, JASPER, LACLEDE, LAWRENCE, MCDONALD, NEWTON, OZARK, POLK, ST. CLAIR, STONE, TANEY, VERNON, WEBSTER, AND WRIGHT COUNTIES

	Rates	Fringes
CEMENT MASON/CONCRETE FINISHER...	\$ 26.57	12.43

PLAS0518-007 04/01/2024		

CASS (Richards-Gebaur AFB only), CLAY, JACKSON, PLATTE AND RAY COUNTIES

	Rates	Fringes
Cement Masons:.....	\$ 37.61	18.71

PLAS0518-011 04/01/2023		

ANDREW, ATCHISON, BATES, BUCHANNAN, CLINTON, DEKALB, GENTRY, HENRY, HOLT, JOHNSON, LAFAYETTE, NODAWAY & WORTH COUNTIES

	Rates	Fringes
CEMENT MASON/CONCRETE FINISHER...	\$ 36.03	20.50

PLAS0527-001 04/01/2023		

	Rates	Fringes
CEMENT MASON		
FRANKLIN, LINCOLN AND		
WARREN COUNTIES.....	\$ 37.29	20.23
JEFFERSON, ST. CHARLES		
COUNTIES AND ST. LOUIS		
(City and County).....	\$ 38.46	20.13

PLAS0527-004 06/01/2023		

CRAWFORD, DENT, IRON, MADISON, MARION, PHELPS, PIKE, PULASKI, RALLS, REYNOLDS, ST. FRANCOIS, STE. GENEVIEVE, SHANNON, TEXAS, WASHINGTON COUNTIES

	Rates	Fringes
CEMENT MASON.....	\$ 32.00	19.72

PLAS0908-001 05/01/2023		

BOLLINGER, BUTLER, CAPE GIRARDEAU, CARTER, DUNKLIN, HOWELL, MISSISSIPPI, NEW MADRID, OREGON, PEMISCOT, PERRY, RIPLEY, SCOTT, STODDARD, AND WAYNE COUNTIES

	Rates	Fringes
CEMENT MASON.....	\$ 32.30	18.38

PLAS0908-005 05/01/2023		

BENTON, CALDWELL, CALLAWAY, CAMDEN, CARROLL, COLE, DAVIESS, GASCONADE, GRUNDY, HARRISON, LIVINGSTON, MACON, MARIES, MERCER, MILLER, MONTGOMERY, MORGAN, OSAGE, PETTIS & SALINE COUNTIES

	Rates	Fringes
CEMENT MASON.....	\$ 32.30	18.38

PLUM0008-003 06/01/2024		

CASS, CLAY, JACKSON, JOHNSON, AND PLATTE COUNTIES

	Rates	Fringes
Plumbers.....	\$ 56.63	24.54

PLUM0008-017 06/01/2024		

BATES, BENTON, CARROLL, HENRY, LAFAYETTE, MORGAN, PETTIS, RAY, ST. CLAIR, SALINE AND VERNON COUNTIES

	Rates	Fringes
Plumbers.....	\$ 56.63	24.54

* PLUM0045-003 08/01/2024

ANDREW, ATCHISON, BUCHANAN, CALDWELL, CLINTON, DAVIESS, DEKALB, GENTRY, HARRISON, HOLT, NODAWAY AND WORTH COUNTIES

	Rates	Fringes
Plumbers and Pipefitters.....	\$ 47.45	26.15

PLUM0178-003 11/01/2023

BARRY, CEDAR, CHRISTIAN, DADE, DALLAS, DOUGLAS, GREENE, HICKORY, LACLEDE, LAWRENCE, POLK, STONE, TANEY, WEBSTER AND WRIGHT COUNTIES

	Rates	Fringes
Plumbers and Pipefitters.....	\$ 37.15	15.42

PLUM0178-006 11/01/2022

BARTON, JASPER, MCDONALD AND NEWTON COUNTIES

	Rates	Fringes
Plumbers and Pipefitters		
Projects \$750,000 & under...	\$ 32.78	15.32
Projects over \$750,000.....	\$ 35.75	15.32

PLUM0533-004 06/01/2024

BATES, BENTON, CARROLL, CASS, CLAY, HENRY, HICKORY, JACKSON, JOHNSON, LAFAYETTE, MORGAN, PETTIS, PLATTE, RAY, SALINE, ST. CLAIR AND VERNON COUNTIES

	Rates	Fringes
Pipefitters.....	\$ 55.56	25.80

PLUM0562-004 07/01/2023

ADAIR, AUDRAIN, BOLLINGER, BOONE, BUTLER, CALLAWAY, CAMDEN, CAPE GIRARDEAU, CARTER, CHARITON, CLARK, COLE, COOPER, CRAWFORD, DENT, DUNKLIN, FRANKLIN, GASCONADE, GRUNDY, HOWARD, HOWELL, IRON, JEFFERSON, KNOX, LEWIS, LINCOLN, LINN, LIVINGSTON, MACON, MADISON, MARIES, MARION, MERCER, MILLER, MISSISSIPPI, MONITEAU, MONROE, MONTGOMERY, NEW MADRID, OREGON, OSAGE, PEMISCOTT, PERRY, PHELPS, PIKE, PULASKI, PUTNAM, RALLS, RANDOLPH, REYNOLDS, RIPLEY, ST. CHARLES, ST. FRANCOIS, STE. GENEVIEVE, ST. LOUIS, SCHUYLER, SCOTLAND, SCOTT, SHANNON, SHELBY, STODDARD, SULLIVAN, TEXAS, WARREN, WASHINGTON, AND WAYNE COUNTIES.

	Rates	Fringes
Plumbers and Pipefitters		
Mechanical Contracts		
including all piping and		
temperature control work		
\$7.0 million & under.....	\$ 46.66	21.99
Mechanical Contracts		
including all piping and		
temperature control work		
over \$7.0 million.....	\$ 46.66	21.99

PLUM0562-016 07/01/2023

CAMDEN, COLE, CRAWFORD, FRANKLIN, JEFFERSON, MARIES, MILLER, MONITEAU, OSAGE, PHELPS, PULASKI, ST. CHARLES, ST. LOUIS (City and County), WARREN and WASHINGTON COUNTIES

	Rates	Fringes
Plumbers		
Mechanical Contracts		
including all piping and		
temperature control work		

\$7.0 million & under.....	\$ 46.66	21.99
Mechanical Contracts including all piping and temperature control work over \$7.0 million.....	\$ 46.66	21.99

TEAM0013-001 05/01/2024

	Rates	Fringes
--	-------	---------

Truck drivers (ADAIR, BUTLER, CLARK, DUNKIN, HOWELL, KNOX, LEWIS, OREGON, PUTNAM, RIPLEY, SCHUYLER AND SCOTLAND COUNTIES)		
GROUP 1.....	\$ 34.29	15.75
GROUP 2.....	\$ 34.44	15.75
GROUP 3.....	\$ 34.56	15.75
GROUP 4.....	\$ 34.45	15.75
Truck drivers (AUDRAIN, BOLLINGER, BOONE, CALLAWAY, CAPE GIRARDEAU, CARTER, COLE, CRAWFORD, DENT, GASCONADE, IRON, MACON, MADISON, MARIES, MARION, MILLER, MISSISSIPPI, MONROE, MONTGOMERY, NEW MADRID, OSAGE, PEMISCOT, PERRY, PHELPS, PIKE, PULASKI, RALLS, REYNOLDS, ST. FRANCOIS, STE. GENEVIEVE, SCOTT, SHANNON, SHELBY, STODDARD, TEXAS, WASHINGTON AND WAYNE COUNTIES)		
GROUP 1.....	\$ 35.02	15.75
GROUP 2.....	\$ 35.17	15.75
GROUP 3.....	\$ 35.29	15.75
GROUP 4.....	\$ 35.18	15.75
Truck drivers (FRANKLIN, JEFFERSON and ST. CHARLES COUNTIES)		
GROUP 1.....	\$ 37.38	15.75
GROUP 2.....	\$ 37.53	15.75
GROUP 3.....	\$ 37.60	15.75
GROUP 4.....	\$ 37.49	15.75
Truck drivers (LINCOLN and WARREN COUNTIES)		
GROUP 1.....	\$ 36.03	15.75
GROUP 2.....	\$ 37.18	15.75
GROUP 3.....	\$ 36.25	15.75
GROUP 4.....	\$ 36.14	15.75

TRUCK DRIVERS CLASSIFICATIONS:

GROUP 1: Flat Bed Trucks, Single Axle; Station Wagons;
Pickup Trucks; Material Trucks, Single Axle; Tank Wagon,
Single Axle

GROUP 2: Agitator and Transit Mix Trucks

GROUP 3: Flat Bed Trucks, Tandem Axle; Articulated Dump
Trucks; Material Trucks, Tandem Axle; Tank Wagon, Tandem
Axle

GROUP 4: Semi and/or Pole Trailers; Winch, Fork & Steel
Trucks; Distributor Drivers and Operators; Tank Wagon,
Semi-Trailer; Insley Wagons, Dumpsters, Half-Tracks,
Speedace, Euclids and other similar equipment; A-Frame and
Derrick Trucks; Float or Low Boy

* TEAM0056-001 05/01/2024

	Rates	Fringes
--	-------	---------

Truck drivers (ANDREW, BARTON, BATES, BENTON, CALDWELL, CAMDEN, CARROLL, CEDAR, CHARITON, CHRISTIAN, CLINTON, COOPER, DADE, DALLAS, DAVIESS, DEKALB, DOUGLAS, GREENE, HENRY, HICKORY, HOWARD, JASPER, LACLEDE, LAWRENCE, LINN, LIVINGSTON, MONITEAU, MORGAN, NEWTON, PETTIS, POLK, RANDOLPH, ST. CLAIR, SALINE, VERNON, WEBSTER AND WRIGHT		
--	--	--

COUNTIES)		
GROUP 1.....	\$ 34.72	15.75
GROUP 2.....	\$ 34.88	15.75
GROUP 3.....	\$ 34.87	15.75
GROUP 4.....	\$ 34.99	15.75

Truck drivers: (ATCHISON,
BARRY, GENTRY, GRUNDY,
HARRISON, HOLT, MCDONALD,
MERCER, NODAWAY, OZARK,
STONE, SULLIVAN, TANEY AND
WORTH COUNTIES)

GROUP 1.....	\$ 33.99	15.75
GROUP 2.....	\$ 34.15	15.75
GROUP 3.....	\$ 34.14	15.75
GROUP 4.....	\$ 34.26	15.75

Truck drivers; (BUCHANAN,
JOHNSON AND LAFAYETTE
COUNTIES)

GROUP 1.....	\$ 35.93	15.75
GROUP 2.....	\$ 36.04	15.75
GROUP 3.....	\$ 36.08	15.75
GROUP 4.....	\$ 36.08	15.75

TRUCK DRIVER CLASSIFICATIONS

GROUP 1: Flat bed trucks single axle; station wagons; pickup trucks; material trucks single axle; tank wagons single axle.

GROUP 2: Agitator and transit mix-trucks.

GROUP 3: Flat bed trucks tandem axle; articulated dump trucks; material trucks tandem axle; tank wagons tandem axle.

GROUP 4: Semi and/or pole trailers; winch, fork & steel trucks; distributor drivers & operators; tank wagons semi-trailer; insley wagons, dumpsters, half-tracks, speedace, euclids & other similar equipment; A-frames and derrick trucks; float or low boy.

TEAM0245-001 03/26/2012

BARRY, BARTON, CAMDEN, CEDAR, CHRISTIAN, DALLAS, DENT, DOUGLAS,
GREENE, HICKORY, HOWELL, JASPER, LACLEDE, LAWRENCE, MCDONALD,
MILLER, NEWTON, OZARK, PHELPS, POLK, PULASKI, SHANNON, STONE,
TANEY, TEXAS, VERNON, WEBSTER AND WRIGHT COUNTIES

Rates Fringes

Truck drivers:

Traffic Control Service Driver.....	\$ 20.45	0.00
--	----------	------

PAID HOLIDAYS: New Year's Day, Decoration Day, July 4th,
Labor Day, Thanksgiving Day, Christmas Day, employee's
birthday and 2 personal days.

TEAM0541-001 04/01/2023

CASS, CLAY, JACKSON, PLATTE AND RAY COUNTIES

Rates Fringes

Truck drivers:

GROUP 1.....	\$ 35.31	17.55
GROUP 2.....	\$ 34.74	17.55
GROUP 3.....	\$ 34.22	17.55

TRUCK DRIVERS CLASSIFICATIONS

GROUP 1: Mechanics and Welders, Field; A-Frame Low Boy-Boomeruck Driver.

GROUP 2: Articulated Dump Truck; Insley Wagons: Dump Trucks, Excavating, 5 cu yds and over; Dumpsters; Half-Tracks: Speedace: Euclids & similar excavating equipment Material trucks, Tandem Two teams; Semi-Trailers; Winch trucks-Fork trucks; Distributor Drivers and Operators; Agitator and Transit Mix; Tank Wagon Drivers, Tandem or Semi; One Team; Station Wagons; Pickup Trucks; Material Trucks, Single Axle; Tank Wagon Drivers, Single Axle

GROUP 3: Oilers and Greasers - Field

ST LOUIS CITY AND COUNTY

	Rates	Fringes
Truck drivers:		
GROUP 1.....	\$ 34.37	8.44+a+b+c+d
GROUP 2.....	\$ 34.37	8.44+a+b+c+d
GROUP 3.....	\$ 34.37	8.44+a+b+c+d

a. PENSION: 5/1/2012 - \$182.20 per week.

b. HAZMAT PREMIUM: If Hazmat certification on a job site is required by a state or federal agency or requested by project owner or by the employer, employees on that job site shall receive \$1.50 premium pay.

TRUCK DRIVERS CLASSIFICATIONS

GROUP 1 - Pick-up trucks; forklift, single axle; flatbed trucks; job site ambulance, and trucks or trailers of a water level capacity of 11.99 cu. yds. or less

GROUP 2 - Trucks or trailers of a water level capacity of 12.0 cu yds. up to 22.0 cu yds. including euclids, speedace and similar equipment of same capacity and compressors

GROUP 3 - Trucks or trailers of a water level capacity of 22.0 cu. yds & over including euclids, speedace & all floats, flatbed trailers, boom trucks, winch trucks, including small trailers, farm wagons tilt-top trailers, field offices, tool trailers, concrete pumps, concrete conveyors & gasoline tank trailers and truck mounted mobile concrete mixers

FOOTNOTE FOR TRUCK DRIVERS:

c. PAID HOLIDAYS: Christmas Day, Independence Day, Labor Day, Memorial Day, Veterans Day, New Years Day, Thanksgiving Day

d. PAID VACATION: 3 days paid vacation for 600 hours of service in any one contract year; 4 days paid vacation for 800 hours of service in any one contract year; 5 days paid vacation for 1,000 hours of service in any one contract year. When such an employee has completed 3 years of continuous employment with the same employer and then works the above required number of hours, he shall receive double the number of days of vacation specified above. When such an employee has completed 10 years of continuous employment with the same employer and then works the above required number of hours, he shall receive triple the number of days of vacation specified above. When such an employee has completed 15 years of continuous employment with the same employer and then works the above required number of hours, he shall receive 4 times the number of days of vacation specified above.

WELDERS - Receive rate prescribed for craft performing operation to which welding is incidental.

=====
Note: Executive Order (EO) 13706, Establishing Paid Sick Leave for Federal Contractors applies to all contracts subject to the Davis-Bacon Act for which the contract is awarded (and any solicitation was issued) on or after January 1, 2017. If this contract is covered by the EO, the contractor must provide employees with 1 hour of paid sick leave for every 30 hours they work, up to 56 hours of paid sick leave each year. Employees must be permitted to use paid sick leave for their own illness, injury or other health-related needs, including preventive care; to assist a family member (or person who is like family to the employee) who is ill, injured, or has other health-related needs, including preventive care; or for reasons resulting from, or to assist a family member (or person who is like family to the employee) who is a victim of, domestic violence, sexual assault, or stalking. Additional information on contractor requirements and worker protections under the EO is available at <https://www.dol.gov/agencies/whd/government-contracts>.

Unlisted classifications needed for work not included within the scope of the classifications listed may be added after award only as provided in the labor standards contract clauses (29CFR 5.5 (a) (1) (iii)).

The body of each wage determination lists the classification and wage rates that have been found to be prevailing for the cited type(s) of construction in the area covered by the wage determination. The classifications are listed in alphabetical order of "identifiers" that indicate whether the particular rate is a union rate (current union negotiated rate for local), a survey rate (weighted average rate) or a union average rate (weighted union average rate).

Union Rate Identifiers

A four letter classification abbreviation identifier enclosed in dotted lines beginning with characters other than "SU" or "UAVG" denotes that the union classification and rate were prevailing for that classification in the survey. Example: PLUM0198-005 07/01/2014. PLUM is an abbreviation identifier of the union which prevailed in the survey for this classification, which in this example would be Plumbers. 0198 indicates the local union number or district council number where applicable, i.e., Plumbers Local 0198. The next number, 005 in the example, is an internal number used in processing the wage determination. 07/01/2014 is the effective date of the most current negotiated rate, which in this example is July 1, 2014.

Union prevailing wage rates are updated to reflect all rate changes in the collective bargaining agreement (CBA) governing this classification and rate.

Survey Rate Identifiers

Classifications listed under the "SU" identifier indicate that no one rate prevailed for this classification in the survey and the published rate is derived by computing a weighted average rate based on all the rates reported in the survey for that classification. As this weighted average rate includes all rates reported in the survey, it may include both union and non-union rates. Example: SULA2012-007 5/13/2014. SU indicates the rates are survey rates based on a weighted average calculation of rates and are not majority rates. LA indicates the State of Louisiana. 2012 is the year of survey on which these classifications and rates are based. The next number, 007 in the example, is an internal number used in producing the wage determination. 5/13/2014 indicates the survey completion date for the classifications and rates under that identifier.

Survey wage rates are not updated and remain in effect until a new survey is conducted.

Union Average Rate Identifiers

Classification(s) listed under the UAVG identifier indicate that no single majority rate prevailed for those classifications; however, 100% of the data reported for the classifications was union data. EXAMPLE: UAVG-OH-0010 08/29/2014. UAVG indicates that the rate is a weighted union average rate. OH indicates the state. The next number, 0010 in the example, is an internal number used in producing the wage determination. 08/29/2014 indicates the survey completion date for the classifications and rates under that identifier.

A UAVG rate will be updated once a year, usually in January of each year, to reflect a weighted average of the current negotiated/CBA rate of the union locals from which the rate is based.

State Adopted Rate Identifiers

Classifications listed under the "SA" identifier indicate that the prevailing wage rate set by a state (or local) government was adopted under 29 C.F.R. 1.3(g)-(h). Example: SAME2023-007 01/03/2024. SA reflects that the rates are state adopted. ME refers to the State of Maine. 2023 is the year during which the state completed the survey on which the listed classifications and rates are based. The next number, 007 in the example, is an internal number used in producing the wage determination. 01/03/2024 reflects the date on which the classifications and rates under the SA identifier took effect under state law in

the state from which the rates were adopted.

WAGE DETERMINATION APPEALS PROCESS

1.) Has there been an initial decision in the matter? This can be:

- * an existing published wage determination
- * a survey underlying a wage determination
- * a Wage and Hour Division letter setting forth a position on a wage determination matter
- * a conformance (additional classification and rate) ruling

On survey related matters, initial contact, including requests for summaries of surveys, should be with the Wage and Hour National Office because National Office has responsibility for the Davis-Bacon survey program. If the response from this initial contact is not satisfactory, then the process described in 2.) and 3.) should be followed.

With regard to any other matter not yet ripe for the formal process described here, initial contact should be with the Branch of Construction Wage Determinations. Write to:

Branch of Construction Wage Determinations
Wage and Hour Division
U.S. Department of Labor
200 Constitution Avenue, N.W.
Washington, DC 20210

2.) If the answer to the question in 1.) is yes, then an interested party (those affected by the action) can request review and reconsideration from the Wage and Hour Administrator (See 29 CFR Part 1.8 and 29 CFR Part 7). Write to:

Wage and Hour Administrator
U.S. Department of Labor
200 Constitution Avenue, N.W.
Washington, DC 20210

The request should be accompanied by a full statement of the interested party's position and by any information (wage payment data, project description, area practice material, etc.) that the requestor considers relevant to the issue.

3.) If the decision of the Administrator is not favorable, an interested party may appeal directly to the Administrative Review Board (formerly the Wage Appeals Board). Write to:

Administrative Review Board
U.S. Department of Labor
200 Constitution Avenue, N.W.
Washington, DC 20210

4.) All decisions by the Administrative Review Board are final.

=====
END OF GENERAL DECISION"

ADA CHECKLIST

ADA CHECKLIST

Revised December 22, 2022

Job No. _____ Route _____ County _____ Location _____

Pedestrian Access Route (PROWAG R204)				
Figures/Examples	Requirements ¹	YES	NO	NA
<p>Sidewalk Width</p> 	<ul style="list-style-type: none"> • The minimum continuous and unobstructed clear width of a pedestrian access route shall be 4.0 feet, exclusive of the width of the curb. • The continuous clear width of pedestrian access routes for medians and pedestrian refuge islands must be 5 feet minimum in order to allow for passing space. • MoDOT Sidewalks shall be 5 feet wide minimum. ² • MoDOT Sidewalks located within 2 feet of the back of curb are to be constructed 6 feet wide minimum and constructed adjacent to the back of the curb. ² • Exception: an unaltered, existing sidewalk shall be 3 feet wide minimum and shall provide 5 foot x 5 foot passing spaces at intervals of 200 feet maximum. ² • Detectable warning surfaces shall be provided, where a curb ramp, landing, or blended transition connects to a street. Where commercial driveways are provided with traffic control devices or otherwise are permitted to operate like public streets, detectable warnings should be provided at the junction between the pedestrian route and the street. • Gratings, access covers, and other appurtenances shall not be located on curb ramps, landings, blended transitions, and gutters within the pedestrian access route. • Grade breaks shall not be permitted on the surface of curb ramps, blended transitions, landings, and gutter areas within the pedestrian access route. Surface slopes that meet at grade breaks shall be flush. 			
<p>Passing Spaces</p>	<ul style="list-style-type: none"> • Walkways in pedestrian access routes that are less than 5 feet in clear width shall provide passing spaces at intervals of 200 feet maximum. • Pedestrian access routes at passing spaces shall be 5 feet wide for a distance of 5 feet. 			
<p>Sidewalk Running Slope The grade that is parallel to the direction of travel, expressed as a ratio of rise to run or as a percent.</p>	<ul style="list-style-type: none"> • The running slope of a pedestrian access route shall be 5 percent maximum. • <u>Roadway Grade Exception:</u> Where pedestrian access routes are contained within a street or highway right-of-way, the grade of the pedestrian access route is permitted to equal the general grade established for the adjacent street or highway. • Running Slopes shall be measured using a calibrated 2 foot long digital level. 			

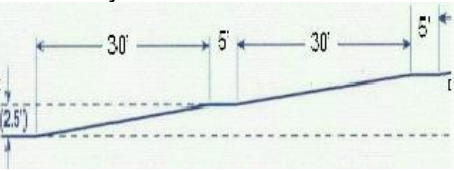
Figures/Examples	Requirements ¹	YES	NO	NA
<p>Sidewalk Cross Slope The grade that is perpendicular to the direction of accessible pedestrian travel, measured perpendicular to the curb line or edge of the street or highway, or measured perpendicular to the running grade.</p>	<ul style="list-style-type: none"> • The cross slope of the walkway of a pedestrian access route shall be 2 percent maximum. (Roadway Grade Exception may be considered) • 2010 ADA/ABA allows for cross slopes of up to ¼ inch per foot (2.08 percent). • In either case, a cross slope measurement of 2.1 percent or greater is not ADA compliant. • Cross Slopes shall be measured using a calibrated 2 foot long digital level. 			
<p>Sidewalk Ramps</p> <p>For example, a ramp segment with the maximum allowed running slope of 8.33% would require 5' x 5' landing after every 30' of run.</p> 	<ul style="list-style-type: none"> • A sidewalk segment (not contained within a street or highway border) with a running grade in excess of 5 percent but less than 8.33 percent is by definition a sidewalk ramp. • The clear width of landings, blended transitions, and curb ramps, excluding flares, shall be 4.0 feet minimum. • Cross slope of ramp runs shall be 2 percent maximum. • The rise for any ramp run shall be 30 inches maximum. • Ramps shall have landings at the top and the bottom of each ramp run. • Ramp runs with a rise greater than 6 inches shall have handrails. • Handrails shall be provided on both sides of stairs and ramps. • Edge protection shall be provided on each side of ramp runs. • Detectable warning surfaces shall be provided, where a curb ramp, landing, or blended transition connects to a street. • Gratings, access covers, and other appurtenances shall not be located on ramps, landings, blended transitions, and gutters within the pedestrian access route. • Grade breaks shall not be permitted on the surface of ramps, blended transitions, landings, and gutter areas within the pedestrian access route. Surface slopes that meet at grade breaks shall be flush. 			

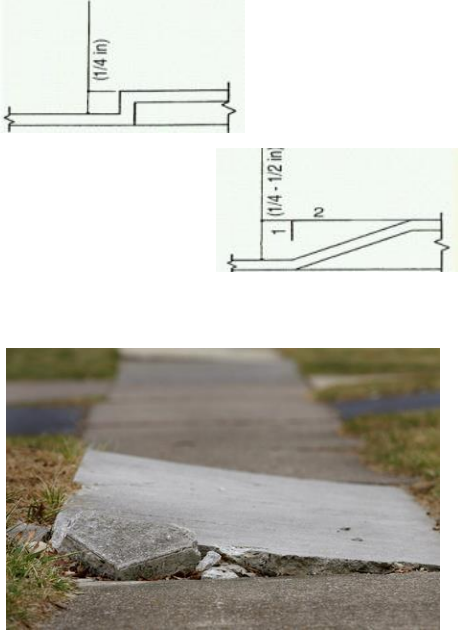
Figures/Examples	Requirements ¹	YES	NO	NA
<p>Vertical Alignment</p>	<ul style="list-style-type: none"> Vertical alignment shall be planar within curb ramp runs, blended transitions, landings, and gutter areas within the pedestrian access route, and within clear spaces required for accessible pedestrian signals, street furniture, and operable parts. Grade breaks shall not be permitted on the surface of curb ramps, blended transitions, landings, and gutter areas within the pedestrian access route. Grade breaks shall be flush. Running Slopes and Cross Slopes shall be measured using a calibrated 2 foot long digital level. Where the pedestrian access route crosses rail tracks at grade, the surface of the pedestrian access route shall be level and flush with the top of the rail at the outer edges of the rail. The surface between the rails shall be aligned with the top of the rail. 			
<p>Changes in Level</p> 	<ul style="list-style-type: none"> Changes in level at grade breaks shall be flush. Changes in level of 1/4 inch high maximum shall be permitted to be vertical. Changes in level between 1/4 inch high maximum and 1/2 inch high maximum shall be beveled with a slope not steeper than 1v:2h. The bevel shall be applied across the entire level change. Changes in level greater than 1/2 inch high shall be ramp grade or flatter, a slope of 8.33 percent or less. 			

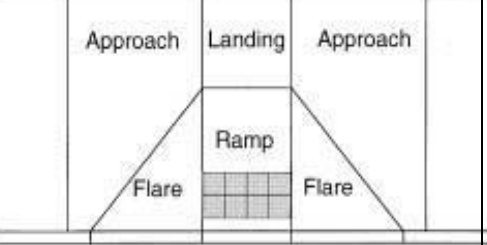
Figures/Examples	Requirements ¹	YES	NO	NA
<p>Landing A required level space required at both ends of a ramp. An area 5' x 5' with no slope greater than 2 percent. This space can be used as a place to rest, turn or pass another user.</p> <p>Landings that are contained within a street or highway border are permitted to use the Roadway Grade Exception for running slopes or cross slopes in the direction of the roadway travel being matched.</p>	<ul style="list-style-type: none"> The landing clear width shall be at least as wide as the widest ramp run leading to the landing. The clear width of landings, blended transitions, and curb ramps, excluding flares, shall be 4 feet minimum. The landing clear length shall be 5 feet long minimum. Landing slopes shall be 2 percent maximum. Changes in level at grade breaks shall be flush. Detectable warning surfaces shall be provided, where a curb ramp, landing, or blended transition connects to a street. Detectable warning shall be located on the landing or blended transition at the back of curb. Gratings, access covers, and other appurtenances shall not be located on curb ramps, landings, blended transitions, and gutters within the pedestrian access route. Grade breaks shall not be permitted on the surface of curb ramps, blended transitions, landings, and gutter areas within the pedestrian access route. Surface slopes that meet at grade breaks shall be flush. 			
 <p>The diagram illustrates a cross-section of a pedestrian access route. It shows a central 'Landing' area flanked by 'Approach' areas. A 'Ramp' with a 'Flare' on each side connects the landing to the approach. Below the landing and approach areas is a 'Gutter'.</p>	<p><u>Roadway Grade Exception:</u> The grade of pedestrian access routes within sidewalks is permitted to equal the general grade established for the adjacent street or highway. The cross slope of curb ramps, blended transitions, landings, and turning spaces at pedestrian street crossings without yield or stop control where vehicles can proceed through the intersection without slowing or stopping, and at midblock pedestrian street crossings are permitted to equal the street or highway grade.</p>			
	<ul style="list-style-type: none"> Running Slopes and Cross Slopes shall be measured using a calibrated 2 foot long digital level. 			

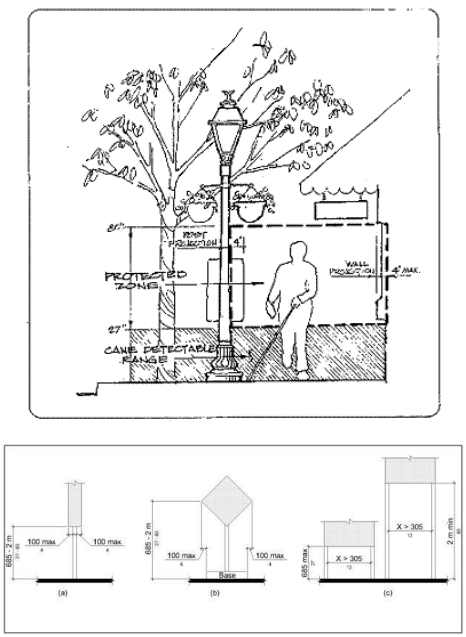
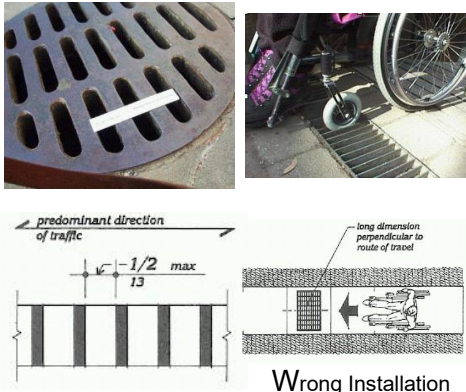
Figures/Examples	Requirements ¹	YES	NO	NA
	<ul style="list-style-type: none"> • Protruding objects on sidewalks and other pedestrian circulation paths shall not reduce the clear width required for pedestrian accessible routes. • Objects with leading edges more than 27 inches and not more than 80 inches above the finish floor or ground shall protrude 4 inches maximum horizontally into the circulation path. • Free-standing objects mounted on posts or pylons shall overhang circulation paths 4 inches maximum measured horizontally from the post or pylon base when located 27 inches minimum and 80 inches maximum above the finish floor or ground. The base dimension shall be 2.5 inches thick minimum. (2011 PROWAG R402.3) • Where a sign or other obstruction is mounted between posts or pylons and the clear distance between the posts or pylons is greater than 12 inches, the lowest edge of such sign or obstruction shall be 27 inches maximum or 80 inches minimum above the finish floor or ground. • Vertical clearance shall be 80 inches high minimum. Guardrails or other barriers shall be provided where the vertical clearance is less than 80 inches high. The leading edge of such guardrail or barrier shall be located 27 inches maximum above the finish floor or ground. • Guardrails or other barriers shall be provided where the vertical clearance is less than 80 inches high. The leading edge of such guardrail or barrier shall be located 27 inches maximum above the finish surface or ground. 			
 <p data-bbox="357 1209 546 1242">Wrong Installation</p>	<ul style="list-style-type: none"> • Openings in floor and ground surfaces shall not allow passage of a sphere more than ½ inch diameter. Elongated openings shall be placed so that the long dimension is perpendicular to the dominant direction of travel. • Gratings, access covers, and other appurtenances shall not be located on curb ramps, landings, blended transitions, and gutters within the pedestrian access route. • Lift holes for manhole/utility covers shall not have an opening greater than ½ inch. Plugging of holes greater than ½ inch with a material approved by the engineer is acceptable as long as it complies with the changes in level requirements. 			

ENTRANCES (PROWAG R301)

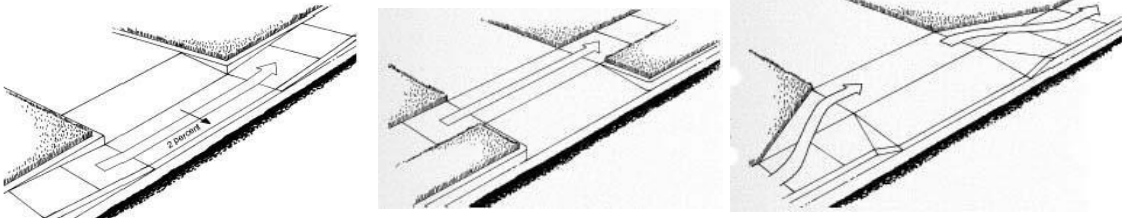
Figures/Examples	Requirements ¹	YES	NO	NA
	<ul style="list-style-type: none"> The minimum continuous and unobstructed clear width of a pedestrian access route provided across commercial and residential entrances shall be 4 feet minimum. Cross slope shall be 2 percent maximum. Be cautious with the transition from the driveway to the roadway to avoid grade combinations that will cause vehicles to bottom out when driving over the transition. ² 			

EDGE PROTECTION (PROWAG R406.8)

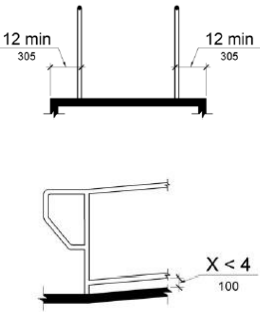
Figures/Examples	Requirements ¹	YES	NO	NA
	<ul style="list-style-type: none"> Edge protection shall be provided on each side of ramp runs and at each side of ramp landings. A curb or barrier shall be provided that prevents the passage of a 4 inch diameter sphere, where any portion of the sphere is within 4 inches of the finish floor or ground surface. Edge-protection shall not be required when the floor or ground surface of the ramp run or landing extends 12 inches minimum beyond the inside face of a handrail. Edge protection shall not be required on curb ramps and their landings. Edge protection shall not be required on ramps that are not required to have handrails and have flares not steeper than 1:10. Edge protection shall not be required on the sides of ramp landings having a vertical drop-off of 1/2 inch maximum within 10 inches horizontally of the minimum landing area. 			

HANDRAIL AND PEDESTRIAN GUARDRAIL (PROWAG R408)

Figures/Examples	Requirements ¹	YES	NO	NA
	<ul style="list-style-type: none"> • The clear width of walking surfaces shall be 4.0 feet minimum. • Handrails are required on ramp runs with a rise greater than 6 inches and on certain stairways. Handrails are not required on walking surfaces with running slopes less than 1:20. Where required, handrails shall be provided on both sides of stairs and ramps. • Handrails shall be continuous within the full length of each stair flight or ramp run. Inside handrails on switchback or dogleg stairs and ramps shall be continuous between flights or runs. • Top of gripping surfaces of handrails shall be 34 inches minimum and 38 inches maximum vertically above walking surfaces, stair nosings, and ramp surfaces. Handrails shall be at a consistent height above walking surfaces, stair nosings, and ramp surfaces. • Clearance between handrail gripping surfaces and adjacent surfaces shall be 1 1/2 inches minimum. • Handrail gripping surfaces with a circular cross section shall have an outside diameter of 1 1/4 inches minimum and 2 inches maximum. • Handrail gripping surfaces with a non-circular cross section shall have a perimeter dimension of 4 inches minimum and 6 1/4 inches maximum, and a cross-section dimension of 2 1/4 inches maximum. • Handrail gripping surfaces and any surfaces adjacent to them shall be free of sharp or abrasive elements and shall have rounded edges. • Handrails shall not rotate within their fittings. • Ramp handrails shall extend horizontally above the landing for 12 inches minimum beyond the top and bottom of ramp runs. Extensions shall return to a wall, guard, or the landing surface, or shall be continuous to the handrail of an adjacent ramp run. • At the top of a stair flight, handrails shall extend horizontally above the landing for 12 inches minimum beginning directly above the first riser nosing. Extensions shall return to a wall, guard, or the landing surface, or shall be continuous to the handrail of an adjacent stair flight. • At the bottom of a stair flight, handrails shall extend at the slope of the stair flight for a horizontal distance at least equal to one tread depth beyond the last riser nosing. Extension shall return to a wall, guard, or the landing surface, or shall be continuous to the handrail of an adjacent stair flight. • See Edge Protection section above (also PROWAG 406.8) for additional details. 			

STAIRWAYS (PROWAG R407)

Figures/Examples	Requirements ¹	YES	NO	NA
	<ul style="list-style-type: none"> All steps on a flight of stairs shall have uniform riser heights and uniform tread depths. Risers shall be 4 inches high minimum and 7 inches high maximum. Treads shall be 11 inches deep minimum. Open risers are not permitted. The radius of curvature at the leading edge of the tread shall be 1/2 inch maximum. Nosings that project beyond risers shall have the underside of the leading edge curved or beveled. Risers shall be permitted to slope under the tread at an angle of 30 degrees maximum from vertical. The permitted projection of the nosing shall extend 1 1/2 inches maximum over the tread below. Stairs shall have handrails complying with PROWAG 2005 R408. 			

UNOBSTRUCTED REACH RANGES (PROWAG R406)

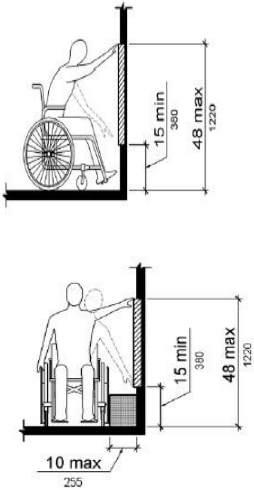
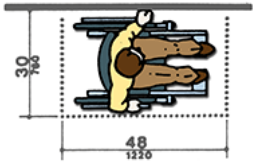
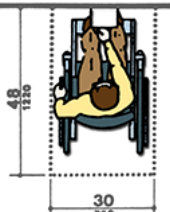
Figures/Examples	Requirements ¹	YES	NO	NA
	<p>Forward Reach</p> <ul style="list-style-type: none"> Where a forward reach is unobstructed, the high forward reach shall be 48 inches maximum and the low forward reach shall be 15 inches minimum above the finish floor or ground. <p>Side Reach</p> <ul style="list-style-type: none"> Where a clear floor or ground space allows a parallel approach to an element and the side reach is unobstructed, the high side reach shall be 48 inches maximum and the low side reach shall be 15 inches minimum above the finish floor or ground. EXCEPTION: An obstruction shall be permitted between the clear floor or ground space and the element where the depth of the obstruction is 10 inches maximum. (2011 PROWAG R406.3) <div style="display: flex; justify-content: space-around; align-items: center;"> <div style="text-align: center;"> <p>Parallel Approach</p>  </div> <div style="text-align: center;"> <p>Forward Approach</p>  </div> </div>			

CURB RAMPS (PROWAG R303)

Figures/Examples	Requirements ¹	YES	NO	NA
<p>A curb ramp, blended transition, or a combination of curb ramps and blended transitions shall connect the pedestrian access routes at each pedestrian street crossing.</p> <p>15 Foot Rule: For a compliant curb ramp to exceed 8.33 percent running grade, its constructed length must exceed 15.0 feet.</p>	<ul style="list-style-type: none"> • The clear width of ramps, excluding the flares, shall be 4.0 feet minimum. • Ramp runs shall have a running slope between 5 percent minimum and 8.33 percent maximum but shall not require the ramp length to exceed 15.0 feet. <p>Exception: 15 Foot Rule: The running slope for a curb ramp is not limited to 8.33 percent maximum if the constructed curb ramp length exceeds 15 feet in length.</p> <ul style="list-style-type: none"> • Cross slope of ramp runs shall be 2 percent maximum. (Roadway Grade Exception may be considered) • The cross slope at midblock crossings shall be permitted to be warped to meet street or highway grade. • Ramps shall have landings at the top and the bottom of each ramp run. <ul style="list-style-type: none"> - The landing clear width shall be at least as wide as the widest ramp run leading to the landing. - The landing clear length shall be 5.0 feet long minimum. - Ramps that change direction between runs at landings shall have a clear landing 5.0 feet minimum by 5.0 feet minimum. • Handrails and Edge protection shall not be required on curb ramps and their landings. • Curb height = 0 inches within curb ramp spaces. 2 • Curb ramps must be flush with street. • The counter slope of the gutter or street at the foot of a curb ramp, landing, or blended transition shall be 5 percent maximum. (R303.3.5) • The adjacent surfaces at transitions at curb ramps to walks, gutters, and streets shall be at the same level. • Flared sides with a slope of 10 percent maximum, measured parallel to the curbline, shall be provided where a pedestrian circulation path crosses the curb ramp. <ul style="list-style-type: none"> - In alterations, where there is no landing at the top of curb ramps, curb ramp flares shall be provided and shall not be steeper than 1:12. • Detectable warning surfaces shall be provided, where a curb ramp, landing, or blended transition connects to a street. • Gratings, access covers, and other appurtenances shall not be located on curb ramps, landings, blended transitions, and gutters within the pedestrian access route. • Grade breaks shall not be permitted on the surface of curb ramps, blended transitions, landings, and gutter areas within the pedestrian access route. Surface slopes that meet at grade breaks shall be flush. • Grade Breaks at the top and bottom of curb ramp runs shall be perpendicular to the direction of the ramp run. 			

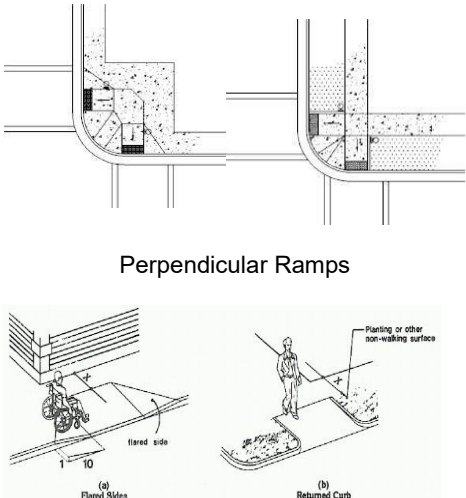
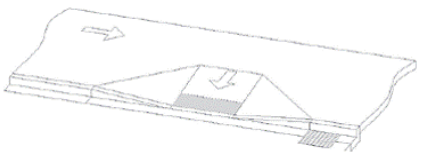
Figures/Examples	Requirements ¹	YES	NO	NA
 <p style="text-align: center;">Perpendicular Ramps</p> <p style="text-align: center;">(a) Flared Sides (b) Returned Curb</p> <p>X = 4' Min. Flared Sides in Pathway Flared Sides Not in Pathway</p> <p><u>Roadway Grade Exception:</u> Where curb ramps, landings and blended transitions are contained within a street or highway right-of-way, the grade of the pedestrian access route is permitted to be modified to equal the general grade established for the adjacent street or highway.</p> 	<ul style="list-style-type: none"> • Perpendicular curb ramps shall have a running slope that cuts through or is built up to the curb at right angles or meets the gutter grade break at right angles. • The clear width of landings, blended transitions, and curb ramps, excluding flares, shall be 4.0 feet minimum. • The running slope shall be 5 percent minimum and 8.33 percent maximum but shall not require the ramp length to exceed 15.0 feet. • The cross slope at intersections shall be 2 percent maximum. (Roadway Grade Exception may be considered) • The cross slope at midblock crossings shall be permitted to be warped to meet street or highway grade. <p><u>Roadway Grade Exception:</u> The grade of pedestrian access routes within sidewalks is permitted to equal the general grade established for the adjacent street or highway. The cross slope of curb ramps, blended transitions, landings, and turning spaces at pedestrian street crossings without yield or stop control where vehicles can proceed through the intersection without slowing or stopping, and at midblock pedestrian street crossings are permitted to equal the street or highway grade.</p> <ul style="list-style-type: none"> • A landing 4.0 feet minimum by 4.0 feet minimum shall be provided at the top of the curb ramp and shall be permitted to overlap other landings and clear space. • Flared sides with a slope of 10 percent maximum, measured parallel to the curbline, shall be provided where a pedestrian circulation path crosses the curbramp. • If the flared sides are not in the pathway (grass next to ramp), then there is no maximum slope and can be vertical curbs. (See adjacent figure for further explanation.) • Detectable warning surfaces shall be provided, where a curb ramp, landing, or blended transition connects to a street. • Gratings, access covers, and other appurtenances shall not be located on curb ramps, landings, blended transitions, and gutters within the pedestrian access route. • Grade breaks at the top and bottom of perpendicular curb ramps shall be perpendicular to the direction of ramp run. At least one end of the bottom grade break shall be at the back of curb. • Grade breaks shall not be permitted on the surface of curb ramps, blended transitions, landings, and gutter areas within the pedestrian access route. Surface slopes that meet at grade breaks shall be flush. • Where both ends of the bottom grade break are 5.0 feet or less from the back of curb, the detectable warning shall be located on the ramp surface at the bottom grade break. Where either end of the bottom grade break is more than 5.0 feet from the back of curb, the detectable warning shall be located on the lower landing. 			

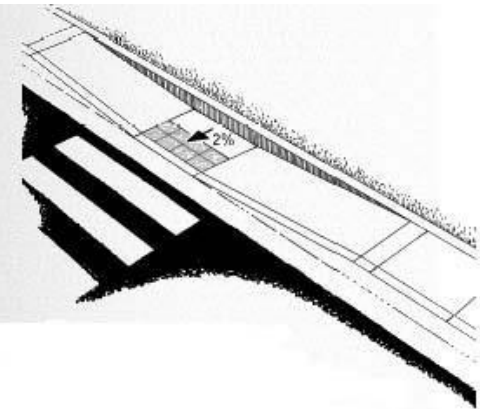
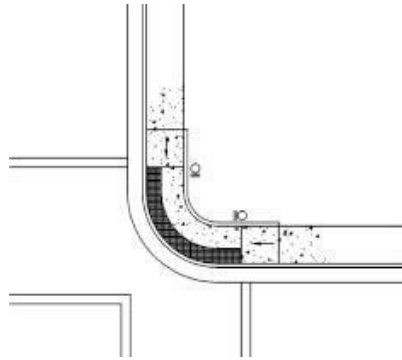

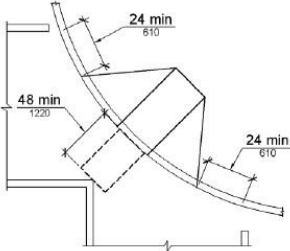
Figures/Examples	Requirements ¹	YES	NO	NA
 <p data-bbox="86 625 562 803">Curb Ramps and landings that are contained within a street or highway border may use the Roadway Grade Exception for slopes or cross slopes in the direction of the roadway travel being matched.</p>	<ul data-bbox="588 138 1722 406" style="list-style-type: none"> • Parallel curb ramps shall have a running slope that is in-line with the direction of sidewalk travel. • The clear width of landings, blended transitions, and curb ramps, excluding flares, shall be 4.0 feet minimum. • The running slope shall be 5 percent minimum and 8.33 percent maximum but shall not require the ramp length to exceed 15.0 feet. • The cross slope shall be 2 percent maximum. (Roadway Grade Exception may be considered) <p data-bbox="630 430 1743 633">Roadway Grade Exception: The grade of pedestrian access routes within sidewalks is permitted to equal the general grade established for the adjacent street or highway. The cross slope of curb ramps, blended transitions, landings, and turning spaces at pedestrian street crossings without yield or stop control where vehicles can proceed through the intersection without slowing or stopping, and at midblock pedestrian street crossings are permitted to equal the street or highway grade.</p> <ul data-bbox="588 657 1722 1063" style="list-style-type: none"> • A landing 4.0 feet minimum by 4.0 feet minimum shall be provided at the bottom of the ramp run and shall be permitted to overlap other landings and clear floor or ground space. • Where a parallel curb ramp does not occupy the entire width of a sidewalk, drop-offs at diverging segments shall be protected. • Detectable warning surfaces shall be provided, where a curb ramp, landing, or blended transition connects to a street. • Gratings, access covers, and other appurtenances shall not be located on curb ramps, landings, blended transitions, and gutters within the pedestrian access route. • Grade breaks shall not be permitted on the surface of curb ramps, blended transitions, landings, and gutter areas within the pedestrian access route. Surface slopes that meet at grade breaks shall be flush. 			
	<ul data-bbox="588 1079 1743 1485" style="list-style-type: none"> • Blended Transitions shall have a running slope of 5 percent maximum and cross slope shall be 2 percent maximum. • The clear width blended transitions, excluding flares, shall be 4.0 feet minimum. • Detectable warning surfaces shall be provided where a blended transition connects to a street. • Gratings, access covers, and other appurtenances shall not be located on blended transitions within the pedestrian access route. • Grade breaks at the top and bottom of perpendicular curb ramps shall be perpendicular to the direction of ramp run. At least one end of the bottom grade break shall be at the back of curb. Grade breaks shall not be permitted on the surface of blended transitions and gutter areas within the pedestrian access route. Surface slopes that meet at grade breaks shall be flush. 			

Figures/Examples	Requirements ¹	YES	NO	NA
 	<ul style="list-style-type: none"> • Diagonal Curb Ramps or corner type curb ramps are no longer preferred design types. A design that provides individual ramps for each crossing direction is recommended by the US Access Board. • Diagonal Curb Ramps or corner type curb ramps with returned curbs or other well-defined edges shall have the edges parallel to the direction of pedestrian flow. • The bottom of diagonal curb ramps shall have a clear space 48 inches minimum outside active traffic lanes of the roadway. • Diagonal curb ramps provided at marked crossings shall provide the 48 inches minimum clear space within the markings. • Diagonal curb ramps with flared sides shall have a segment of curb 24 inches long minimum located on each side of the curb ramp and within the marked crossing. <p>Roadway Grade Exception: The grade of pedestrian access routes within sidewalks is permitted to equal the general grade established for the adjacent street or highway. The cross slope of curb ramps, blended transitions, landings, and turning spaces at pedestrian street crossings without yield or stop control where vehicles can proceed through the intersection without slowing or stopping, and at midblock pedestrian street crossings are permitted to equal the street or highway grade.</p> <ul style="list-style-type: none"> • Detectable warning surfaces shall be provided, where a curb ramp, landing, or blended transition connects to a street. • Gratings, access covers, and other appurtenances shall not be located on curb ramps, landings, blended transitions, and gutters within the pedestrian access route. • Grade breaks shall not be permitted on the surface of curb ramps, blended transitions, landings, and gutter areas within the pedestrian access route. Surface slopes that meet at grade breaks shall be flush. • Running and cross slope at midblock crossings shall be permitted to be warped to meet street or highway grade. 			

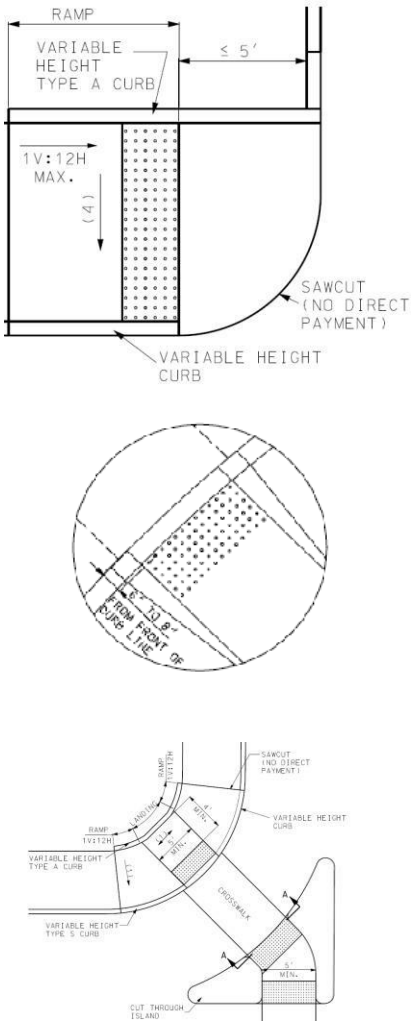

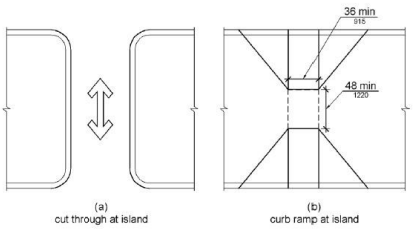

DETECTABLE WARNINGS DEVICES (TRUNCATED DOMES) (PROWAG R304)

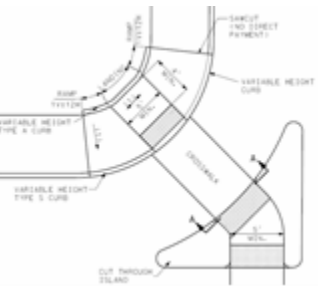
Figures/Examples	Requirements ¹	YES	NO	NA
<p>A surface feature of truncated dome material built in or applied to the walking surface to advise of an upcoming change from pedestrian to vehicular way.</p> 	<ul style="list-style-type: none"> • Detectable warnings shall consist of a surface of truncated domes aligned in a square or radial grid pattern complying with 2010 ADA Standards. Detectable warning surfaces shall contrast visually with adjacent gutter, street or highway, or walkway surfaces, either light-on-dark or dark-on-light. • Detectable warning surfaces shall extend 24 inches minimum in the direction of travel and the full width of the curb ramp (exclusive of flares), the landing, or the blended transition. Detectable warning surfaces are required where curb ramps, blended transitions, or landings provide a flush pedestrian connection to the street. • Sidewalk crossings of residential driveways should not generally be provided with detectable warnings, since the pedestrian right-of-way continues across most driveway aprons and overuse of detectable warning surfaces should be avoided in the interests of message clarity. However, where commercial driveways are provided with traffic control devices or otherwise are permitted to operate like public streets, detectable warnings should be provided at the junction between the pedestrian route and the street. • Perpendicular Curb Ramps: Where both ends of the bottom grade break are 5 feet or less from the back of curb, the detectable warning shall be located on the ramp surface at the bottom grade break. Where either end of the bottom grade break is more than 5 feet from the back of curb, the detectable warning shall be located on the lower landing. • Landings and Blended Transitions: The detectable warning shall be located on the landing or blended transition at the back of curb. • Rail Crossings: The detectable warning surface shall be located so that the edge nearest the rail crossing is 6 feet minimum and 15 feet maximum from the centerline of the nearest rail. The rows of truncated domes in a detectable warning surface shall be aligned to be parallel with the direction of wheelchair travel. • Detectable warnings at cut-through islands shall be located at the curb line in-line with the face of curb and shall be separated by a 2.0 foot minimum length of walkway without detectable warnings. Where the island has no curb, the detectable warning shall be located at the edge of roadway. • Exception, when detectable warnings are required by a manufacturer's installation specifications to be embedded into concrete with a surrounding edge, domes may be installed at less than the required full width. Under this exception, the detectable warning surface shall never be more than 2 inches from the edge of the curb ramp, the landing, or the blended transition. ² • Detectable warnings shall not be stamped into concrete. 			

ISLANDS AND MEDIANS (PROWAG R305.4)

Figures/Examples	Requirements ¹	YES	NO	NA
 <p style="text-align: center;">(a) cut through at island (b) curb ramp at island</p>  	<ul style="list-style-type: none"> Medians and pedestrian refuge islands in crosswalks shall contain a pedestrian access route, including passing space and connecting to each crosswalk. Raised islands in crossings shall be cut through level with the street or have curb ramps and required landings at both sides. All median island passage spaces shall provide a clear width of 5 feet minimum. ² Medians and pedestrian refuge islands shall be 6.0 feet minimum in length in the direction of pedestrian travel. <p><u>Roadway Grade Exception:</u> The grade of pedestrian access routes within sidewalks is permitted to equal the general grade established for the adjacent street or highway. The cross slope of curb ramps, blended transitions, landings, and turning spaces at pedestrian street crossings without yield or stop control where vehicles can proceed through the intersection without slowing or stopping, and at midblock pedestrian street crossings are permitted to equal the street or highway grade.</p> <ul style="list-style-type: none"> Each curb ramp shall have a level area 48 inches long minimum by 36 inches wide minimum at the top of the curb ramp in the part of the island intersected by the crossings. Each 48 inch minimum by 36 inch minimum area shall be oriented so that the 48 inch minimum length is in the direction of the running slope of the curb ramp it serves. The 48 inch minimum by 36 inch minimum areas and the accessible route shall be permitted to overlap. Detectable warning surfaces shall be provided, where a curb ramp, landing, or blended transition connects to a street. Medians and pedestrian refuge islands shall have detectable warnings at curb ramps and blended transitions. Detectable warnings at cut-through islands shall be located at the curb line in-line with the face of curb and shall be separated by a 2.0 foot minimum length of walkway without detectable warnings. Where the island has no curb, the detectable warning shall be located at the edge of roadway. Gratings, access covers, and other appurtenances shall not be located on curb ramps, landings, blended transitions, and gutters within the pedestrian access route. Grade breaks shall not be permitted on the surface of curb ramps, blended transitions, landings, and gutter areas within the pedestrian access route. Surface slopes that meet at grade breaks shall be flush. 			

ACCESSIBLE PEDESTRIAN SIGNALS (PUSHBUTTONS) (PROWAG R306 and EPG 902.6.1 – EPG 902.6.15)

Figures/Examples	Requirements ¹	YES	NO	NA
    	<ul style="list-style-type: none"> • Each crosswalk with pedestrian signal indication shall have an accessible pedestrian signal which includes audible and vibrotactile indications of the WALK interval at new signalized intersections and shall be considered at existing intersections being altered or are needing maintenance applications. Where a pedestrian pushbutton is provided, it shall be integrated into the accessible pedestrian signal. • Accessible pedestrian signals shall be located so that the vibrotactile feature can be contacted from the level landing serving a curb ramp, if provided, or from a clear floor or ground space that is in line with the crosswalk line adjacent to the vehicle stop line. • Accessible pedestrian pushbuttons shall be located within a reach range complying with EPG 642. • A clear floor or ground space shall be provided at the pushbutton and shall connect to or overlap the pedestrian access route. <p>Roadway Grade Exception: Clear spaces required at accessible pedestrian signals and pedestrian pushbuttons and at other accessible elements are permitted to have a running slope or cross slope consistent with the grade of the adjacent pedestrian access route.</p> <ul style="list-style-type: none"> • Pedestrian signals shall comply with PROWAG 2005 R306 and EPG 902.6.1 through 902.6.15. <ul style="list-style-type: none"> - Pushbuttons are a minimum 2 inches across in one dimension, raised (not recessed), contrast visually with the housing or mounting, and have a maximum force of 3.5 pounds to activate operable parts. - The control face of the pushbuttons is installed parallel to the direction of the crosswalk it serves. - The location of pushbuttons for new construction are within a longitudinal distance of 5 feet maximum from the crosswalk line, and 30 inches minimum to 6 feet maximum from the curb line. - For audible pedestrian signal devices only, pushbuttons are a minimum 10 feet apart. - Pushbuttons are located at a height of approximately 42 inches, but no higher than 48 inches from the ground and within 10 inch reach from a level paved clear floor or ground space with minimum dimensions of 48 inches x 30 inches positioned for a parallel approach to the pushbutton. For a forward approach space (30 x 48 inches) the allowed reach range is 0 inches. - Where pushbuttons for the visually impaired are installed, tactile signs are to be provided that meet ADA requirements. 			

PEDESTRIAN STREET CROSSINGS (PROWAG R305 and EPG 642)

Figures/Examples	Requirements ¹	YES	NO	NA
	<ul style="list-style-type: none"> • Crosswalks shall contain a pedestrian access route that connects to departure and arrival walkways through any median or pedestrian refuge island. • Marked crosswalks shall be 6 feet wide minimum. • The grade of the pedestrian access route is permitted to equal the general grade established for the adjacent street or highway, except that where pedestrian access routes are contained within pedestrian street crossings a maximum grade of 5 percent is required. • A 5 percent maximum cross slope is specified for pedestrian access routes contained within pedestrian street crossings without yield or stop control. • Crossings with Stop Control: The cross slope shall be 2 percent maximum. • The cross slope at midblock crossings shall be permitted to be warped to meet street or highway grade. • The running slope shall be 5 percent maximum, measured parallel to the direction of pedestrian travel in the crosswalk. • Accessible pedestrian signals and pedestrian pushbuttons provided at pedestrian crossings with pedestrian signals (See EPG 642 for applicability) shall comply with EPG 902.6.8 through 902.6.15. Operable parts shall comply with EPG 902.6.9 – 902.6.15. • Crosswalk pavement marking is 6 inches wide white. • Stop bar is at minimum 4 feet from the crosswalk. • Curb ramps at marked crossings shall be wholly contained within the markings, excluding any flared sides. • Gratings, access covers, and other appurtenances shall not be located on curb ramps, landings, blended transitions, and gutters within the pedestrian access route. • Grade breaks shall not be permitted on the surface of curb ramps, blended transitions, landings, and gutter areas within the pedestrian access route. Surface slopes that meet at grade breaks shall be flush. • Beyond the curb face, a clear space of 4.0 feet minimum by 4.0 feet minimum shall be provided within the width of the crosswalk and wholly outside the parallel vehicle travel lane. 			

ALTERNATE CIRCULATION PATH (PROWAG R302)

Figures/Examples	Requirements ¹	YES	NO	NA
	<ul style="list-style-type: none"> • Alternate circulation paths shall contain a pedestrian access route. • To the maximum extent feasible, the alternate circulation path shall be provided on the same side of the street as the disrupted route. • Where the alternate circulation path is exposed to adjacent construction, excavation drop-offs, traffic, or other hazards, it shall be protected with a pedestrian barricade or channelizing device complying with MUTCD 6F-58, 6F-63, and 6F-66. • Pedestrian barricades and channelizing devices shall be continuous, stable, and non-flexible and shall consist of a wall, fence, or enclosures specified in section 6F-58, 6F-63, and 6F-66 of the MUTCD (incorporated by reference; see PROWAG 2005 R104.2.4). • A detectable continuous bottom edge shall be provided 2 inches maximum above the ground or walkway surface. • Devices shall provide a continuous surface or upper rail at 3.0 feet minimum above the ground or walkway surface. • Support members shall not protrude into the alternate circulation path. 			

BUS BOARDING AND ALIGHTING AREAS (PROWAG R410)

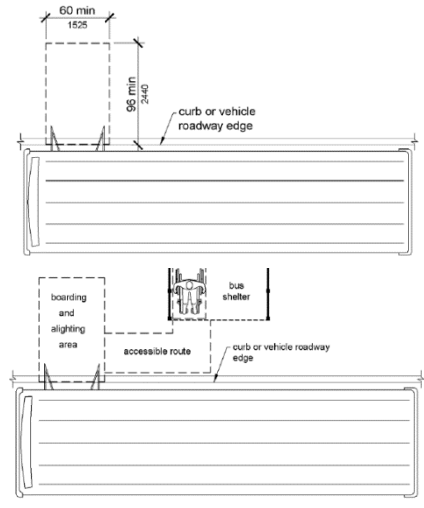
Figures/Examples	Requirements ¹	YES	NO	NA
	<ul style="list-style-type: none"> • Bus stop boarding and alighting areas shall have a firm, stable surface. • Bus stop boarding and alighting areas shall provide a clear length of 8 feet minimum, measured perpendicular to the curb or vehicle roadway edge, and a clear width of 5 feet minimum, measured parallel to the vehicle roadway. • Bus stop boarding and alighting areas shall be connected to streets, sidewalks, or pedestrian paths by an accessible route. • Parallel to the roadway, the slope of the bus stop boarding and alighting area shall be the same as the roadway, to the maximum extent practicable. Perpendicular to the roadway, the slope of the bus stop boarding and alighting area shall not be steeper than 2 percent. • Bus shelters shall provide a minimum 30 inch by 48 inch clear floor or ground space entirely within the shelter. • Bus shelters shall be connected by an accessible route to a boarding and alighting area. 			

¹ Any “NO” answer means that location is ADA non-compliant and needs to be corrected before final acceptance of the work, except as follows. Although exceptions listed in the above requirements may not meet MoDOT current policy standards, work that does meet the minimum ADA standards will be accepted as ADA compliant. Where it is technically infeasible to correct deficiencies as part of the current work, those locations will be labeled as non-compliant and marked “NO”. These items will be added to the Transition Plan Inventory for correction at a later date. (Guidance is provided in ADA documents and in the EPG on what may be considered as technically infeasible.)

² A MoDOT requirement.

Unless otherwise noted, all notes on this form are direct ADA requirements as published in either the PROWAG dated November 23, 2005 or ADA/ABA Standards from 2010.

All exceptions and technically infeasible locations should be discussed with the project manager and/or area engineer prior to acceptance of the work. All exceptions and technically infeasible locations will need to be thoroughly documented by the engineer, and that documentation will be attached to this form and retained as part of the final acceptance records.

All slope and grade measurements for ADA compliance will be made using a calibrated 2 foot long digital level.

US Access Board PROWAG

R202.3.1 Prohibited Reduction in Required Access. An alteration shall not decrease or have the effect of decreasing the accessibility of a facility or an accessible connection to an adjacent building or site below the requirements for new construction in effect at the time of the alteration.

Inspector Name: _____ Inspector Signature: _____	Date:
Contractor Representative Name: _____ Contractor Representative Signature: _____	Date:
Resident Engineer or Area Engineer Name: _____ Resident Engineer or Area Engineer Signature: _____	Date:
Distribution: <input type="checkbox"/> Project Office <input type="checkbox"/> District Permit Office	

SAMPLE

ADA EXCEPTIONS DOCUMENTATION

Job No. _____ Route _____ County _____ Location _____

<u>Item</u>	<u>Location</u>	<u>Standard</u>	<u>As Built</u>	<u>Discussion</u>
Sidewalk Width	Third Street Sta 3+00 to 7+00 RT	5' wide	Exist 3' wide	Required 5' x 5' Passing Space added at 5+00
Curb Ramp Grade	SE Quad of Main & First	8.33%	11.2%	As-built Curb Ramp is 16.0' long
Parallel Ramp Landing running grade (turning space)	Sta 35+20 to 35+25 Rt Rte 14	2.00%	2.6%	Landing running grade matches existing roadway grade
Sidewalk Grade	Sta 23+45 to 23+52	5.0%	8.4%	Match existing floor at two exist doorways, Straight grade between fixed elevations

Inspector Name: _____	
Inspector Signature: _____	Date:
Resident Engineer or Area Engineer Name: _____	
Resident Engineer or Area Engineer Signature: _____	Date:
Distribution: <input type="checkbox"/> Project Office <input type="checkbox"/> District Permit Office	

ENVIRONMENTAL CLEARANCE DOCUMENTATION

This RER is being processed, it can still be edited. You will be notified when it is completed.

Date Updated: 10/07/2021
Updated By: Kyleen Kelly

Request for Environmental Review Form#:2021-02-00073

Alternative Project Delivery Method (such as Design/Build)

Project Information

Prefix:	STP	Project Number:	5622602	Bridge Number:	
District:	St. Louis	County:	St. Louis	Sponsor:	City of Florissant
				Sponsor Email:	cwilcox@lochgroup
TIP Number:	6921-20	Rte/Street:	6200 Vogel Road		
MoDOT Job Number:		TIGER Grant Funds:		Is this project on or adjacent to MoDOT Right of Way:	No
Location/Stream Crossing :	RUE ST DENIS				
TMS Project Description - termini (no stations):	RUE ST DENIS PHASE 1 - RESURFACING/SIDEWALKS - ST FERDINAND ST TO N LAFAYETTE ST				
Describe RER project improvements in full detail:	Improvements consist of corridor preservation project on Rue St. Denis Street between N Lafayette Street Ferdinand Street and on N Jefferson St between Rue St. Denis Street and Rue St. Antoine Street. The project includes re-profiling the existing pavement, with the base repair as necessary, adding 2.5-inch asphalt overlay, as well as the installation of stormwater sewers and concrete curb and gutter along the alignment. ADA Compliant sidewalk will be constructed along the road and pedestrian crosswalks will be installed at intersections. Parking lanes will also be constructed along portions of the roadway. Right of way is anticipated to be required for Stormwater BMPs and perhaps sidewalk with an anticipated maximum of 0.16 acres needed.				
District Liaison:	Thomas McCloskey - 314-453-1831	Contact:	None selected		
Email:	Thomas.McCloskey@modot.mo.gov	Email:	cwilcox@lochgroup.com		
Contact:	None selected	Contact:	None selected		
Email:		Email:			
Date Desired:	03/12/2021	Submit Date:	02/11/2021		

Desired A-Date:

Responsible Individual: [Collin Wilcox - \(2/2/2021 11:34:30 AM\)](#) - 314-621-3395

Submitted By: [Collin Wilcox - \(2/11/2021 12:00:00 AM\)](#) - 314-621-3395

Existing Condition

ADT:	3259	Speed Limit:	25
Number of Travel Lanes:	2	Lane Width:	12
Shoulder Width:	0	Curb and Gutter:	No
Bridge width, measured from gutterline to gutterline:	0	Sidewalks:	None

Proposed Design Improvement

ADT:	3422	Speed Limit:	25	Design Speed:	25
Number of Travel Lanes:	0	Lane Width:	0	Curb and Gutter:	Yes
Shoulder Width:	0	Sidewalks:	None		
Bridge width, measured from gutterline to gutterline:	0				
Bridge Length:	0	Roadway length:	0.33 Miles		
Railroad Crossing	No	Drainage District (If Applicable):	Choose One...		

Program Year:

Preliminary Engineering: 2021

Right of Way: 2021

Construction: 2022

Has the sponsor documented that the project has:
1. Independent utility,
2. Logical termini, and
3. Does not restrict consideration of alternatives for other reasonably foreseeable transportation improvements?:
 Yes No

Project breakout from previous or larger project? *If checked explain:*
This is the first phase of the multiple phase project along Rue St. Denis between St. Ferdinand St and N New Florissant Rd

Acres - From all sources (e.g. donated from public or private entities):

Additional R/W (acres): 0.16

Temp Easement (acres): 0.71

Permanent Easement (acres): 0.01

ROW may be needed, but, not yet determined? Yes

Is ANY Federally-owned land impacted by the project? Yes No

Land Disturbance:

Will project involve 1 acre or more: Yes

Acres of Tree Clearing: 0.05 acres

DO NOT CLEAR TREES W/O MODOT'S PRIOR WRITTEN APPROVAL.

Number of Displacements(do not include partial takes that do not displace):

Residential: Yes No

Commercial: Yes No

No. of People: Residences: 0

No. of Employees: Businesses: 0

Any Public Involvement planned or completed:

An open house is tentatively planned for September 2021, which will give every affected property owner an opportunity to view the project plans and voice any questions/concerns to the City.

Average Daily Traffic:

ADT Construction Year: 2018

ADT Design Year: 2038

Traffic Impacts:

Road Closure Planned: Yes No

Bridge Closure Planned: Yes No

Days/Months Closed:

Detour > 25 mi rural Yes No

Detour > 5 mi urban (inside MPO) Yes No

Detour Info:

Bicycle / Pedestrian Consideration

Pedestrian facilities considered: Yes

Bicycle facilities considered: Yes

National Flood Insurance Program (NFIP) and Hydraulic Design Data:

Project is in a FEMA-identified zone "subject to 100-year flooding": *If so, what zone?:*

Project is in a FEMA- No
defined "floodway"

Project involves land purchased through FEMA Hazard Mitigation Grant Program (Flood buyout property)

If checked, give details:

Is ANY construction taking place on MoDOT owned property under this project?

Yes No

Is highway improvement located within 4 miles of an existing airport?

Known Concerns: Provide information you have about these resources that you have observed in the area.

Parkland: NA

Wetland/404 Permit: NA

Land Disturbance / Stormwater: Water quality features will likely be required by Metropolitan St. Louis Sewer District

Farmland: NA

Threatened &
Endangered Species:

Migratory Birds: Are there birds nesting on the structure? No, There are no large structures or culverts within the project limits. Therefore, no migratory bird activities are expected to be impacted during construction.

Hazardous Waste: NA

Cultural Resources: Project goes through historic district buildings, Section 106 approval has been granted by the SHPO (see attached letter)

LPA Comments:

Project Attachments:

****NOTE: If making updates to an attachment, please use a different filename than the original.**

****The combined size of attachments in one upload must be less than 100MB**

Attachments:

- ✘ 122-SL-21 - Supplemental Review Request.pdf
- ✘ 122SL21-2803 nae.pdf
- ✘ STP-5622(602) - Rue St Denis Phase I - Right of Way Plans.pdf
- ✘ 122SL21- 2390 nae.pdf
- ✘ Rue St Denis Tree Assessment.pdf
- ✘ NHRR Review - Rue St. Denis Street Improvement.pdf
- ✘ Rue St Denis Phase I - Endangered Species Evaluation.pdf
- ✘ MDC_project_report_rue_st_denis_street_i_33243_38001_FINAL.pdf
- ✘ Draft Section 106 Supporting Documentation (Rev 3).pdf
- ✘ Draft 106 Application Form (Rev 3).pdf
- ✘ Species List_Missouri Ecological Services Field Office.pdf
- ✘ Public Land Impact (Section 4f-6f) Clearance Request.pdf
- ✘ Topo Map - Relevant Portion.pdf

Required Information to be attached for each RER stage:

- Location map (county map, topographic map or aerial map) showing the project limits
- plan sheets
- KMZ files showing tree clearing limits and/or plans
- permits/documentation as required (floodplain, farmland form, NWP, asbestos & lead based paint inspection reports, Section 106 Project Information Form for review, SHPO concurrence letter, USFWS IPac Official Species List, MDC Heritage Review Report, Effects determination)

RER Environmental Screenings

Farmland Impact

Status Information:

N/A Pending Cleared

Clearance Date:

Environmental Response: The project is in a designated urbanized area (St. Louis MO-IL 77770) as indicated on the U.S. Census Bureau Urban Area Reference Map. Therefore, the project is not subject to the Farmland Protection Policy Act.

LPA Action: None

Attachments:

- Farmland Impact Submitted - Mark submitted when this review is ready to be sent to district staff.

Last Updated: Kyleen Kelly - 2/15/2021 8:46:19 AM

► Floodplain/Regulatory Floodway

Status Information: N/A Pending Cleared Clearance Date:

Environmental Response: According to the attached FEMA floodplain map, the project is not located in the 100-year floodplain or the regulatory floodway. The project is not subject to floodplain permitting requirements.

LPA Action: None

Attachments:

 [FIRMETTE_RueStDenis.pdf](#)

Floodplain/Regulatory Floodway Submitted - *Mark submitted when this review is ready to be sent to district staff.*
Last Updated: Kyleen Kelly - 2/15/2021 8:46:46 AM

► Land Disturbance / Stormwater

Status Information: N/A Possible Issues Noted Clearance Date:

Environmental Response: If the project is in a regulated MS4 area, adhere to the MS4 requirements as defined in the MS4 permit specific to that municipality. Stormwater routed into MoDOT's drainage system (e.g., ditches and stormwater conveyance systems) must be treated for water quality and/or quantity before entering the system. Any project with land disturbance of 1-acre or more requires a NPDES land disturbance permit from MDNR.

LPA Action: If the project will disturb 1-acre or more of land, obtain a NPDES land disturbance permit from DNR. The LPA must also implement best management practices in accordance with that permit and the Clean Water Act.

Attachments:

Land Disturbance / Stormwater Submitted - *Mark submitted when this review is ready to be sent to district staff.*
Last Updated: Kyleen Kelly - 2/15/2021 8:47:09 AM

► FEMA/SEMA Buyout

Status Information: N/A Pending Cleared Clearance Date:

Environmental Response: According to the ArcMap GIS FEMA buyout layer, there are no flood buyout sites in the vicinity of the project area. The project will not result in development on any FEMA buyout properties.

LPA Action: None

Attachments:

FEMA/SEMA Buyout Submitted - *Mark submitted when this review is ready to be sent to district staff.*
Last Updated: Kyleen Kelly - 2/15/2021 8:47:30 AM

► Socioeconomic Impact

Status Information: N/A Pending Cleared Clearance Date:

Environmental Response: UPDATE 9/13/2021: New project footprint does not impact Socioeconomic impacts associated with the project. There are no significant socioeconomic impacts associated with this project. Impacts will be temporary and limited to traffic disruptions, construction noise, and fugitive dust and emissions in the area of project construction. UPDATE 8/25/2021: Public involvement information has been provided. Project footprint is being updated and this section will require and updated review once plans are available. INITIAL: The project does not require commercial or residential displacements and no new right of way or easements. The consultant indicates that a road closure will be necessary. There are no significant socioeconomic impacts associated with this project. Impacts will be temporary and limited to traffic disruptions, construction noise, and fugitive dust and emissions in the area of project construction.

LPA Action: UPDATE 9/13/2021: Conduct the acquisition of affected properties in accordance with the procedures established in the Uniform Relocation Assistance and Real Property Acquisition Policies Act of 1970, as amended. Provide sufficient public notice of construction work and traffic management plans consistent with MoDOT's and local public involvement policies and procedures. Ensure a traffic management control plan is implemented by the contractor during construction which should include how the public will be notified of travel disruptions. INITIAL: 1. Provide information on any public involvement (meetings, public comments, communications, etc.). 2. Provide information about road closure (length of time, detour information, etc.) and information about access to residences and businesses along the project route during closure.

Attachments:

Socioeconomic Impact Submitted - *Mark submitted when this review is ready to be sent to district staff.*
Last Updated: Kyleen Kelly - 9/13/2021 11:14:10 AM

Threatened & Endangered Species

Status Information:

No Effect Pending Cleared

Clearance Date:

08/25/2021

Environmental Response: UPDATE 9/13/2021: Updated footprint will not result in additional tree clearing for the project. Based on the lack of new clearing or impacts to other TE species, the original TE determination of No Effect for gray bat, Indiana bat, northern long-eared bat, and decurrent false aster remains valid. If additional tree clearing is required, notify MoDOT for an updated TE review. UPDATE 8/25/2021: Project footprint is being changed. TE will require a re-evaluation. Status changed to "Pending" until the re-evaluation is completed. UPDATE 8/17/2021: MoDOT has completed a TE review for the project (effects determination attached). The USFWS IPaC lists the following species for the project area: gray bat, Indiana bat, northern long-eared bat, and decurrent false aster. There are no critical habitats located within the project limits. The MDC Level 2 follow-up report did not indicate the presence of any state-listed species or species of conservation concern within 1 mile of the project; based on the lack of nearby occurrences, the project will not impact state-protected species. MoDOT determined that the project will have No Effect on the gray bat, Indiana bat, northern long-eared bat, or decurrent false aster. Nothing further is required, and TE is complete for the project. UPDATE 8/12/2021: Consultant has provided the requested materials, including tree photos. MoDOT is completing a TE review based on this information and will notify the sponsor/consultant when complete. UPDATE 7/27/2021: Consultant has uploaded the follow-up MDC report. Nothing further required. Photo documentation of trees to be removed are needed to complete the TE review. UPDATE 7/19/2021: MoDOT is completing a TE review based on materials provided by the consultant. MoDOT will notify the consultant and sponsor when complete. INITIAL: Impacts to threatened and endangered species must be assessed for this project.

LPA Action: COMPLETE: If additional tree clearing becomes necessary, notify MoDOT for an updated TE review. UPDATE 7/26/2021: Please provide photos of trees that may be removed as a result of the project, as well as an assessment of whether or not any of the trees may provide suitable summer roost habitat for Indiana and northern long-eared bats. UPDATE 7/19/2021: Based on the Level 2 findings of the MDC report, contact MDC for a detailed follow-up report. Upload the follow-up report to the RER, when received. INITIAL: 1. Access the US Fish and Wildlife Service (USFWS) IPaC online tool at <http://ecos.fws.gov/ipac/> to obtain the official list of species for your county. 2. LEVEL TWO REPORT ATTACHED. Access the MO Department of Conservation (MDC) online Natural Heritage Review website at <https://naturalheritagereview.mdc.mo.gov/> and generate a report. Contact MDC if the report indicates to do so. Submit the report, and MDC response, if required, to MoDOT. 3. Provide the amount, location, and time of year for tree clearing, or indicate there will be no tree clearing. 4. If there will be tree clearing, photograph the trees so that bark characteristics of the main trunk and large branches, along with any cavities, are clearly illustrated. 5. If the project involves bridgework, photograph the undersides of bridges illustrating any bird nests or unusual staining on the substructure or underside of the deck. 6. It is the responsibility of the LPA to make a written determination of their project impacts on each species listed from the IPaC. Further, the LPA must assess effects on any MDC listed species (endangered or species of conservation concern). If no effects are anticipated for a particular species, state the reason(s) why. For example: This project does not involve any tree clearing so there will be no effects on summer roosting habitat for listed bat species or this project does not impact any aquatic habitats so there will be no effects on listed fish or mussel species. 7. Submit the full project limits, easements, access, construction date, and ground disturbance information.

Attachments:

[✖Email_TE Complete - No Effect STP-5622\(602\) St. Louis Rue St. Denis Improvements.pdf](#)

[✖STP-5622\(602\)_MoDOT Effects Determination_StLouis_RueStDenis_Aug2021_FINAL.pdf](#)

[✖TE and MBTA Checklist.pdf](#)

Threatened & Endangered Species Submitted - Mark submitted when this review is ready to be sent to district staff.

Last Updated: Kyleen Kelly - 9/13/2021 11:16:37 AM

Migratory Birds

Status Information:

N/A Pending Cleared

Clearance Date:

Environmental Response: UPDATE 3/8/2021: Consultant has confirmed that there are no bridges or other structures associated with the project that could provide migratory bird nesting habitat. Based on this information, there are no conflicts with the MBTA and no anticipated impacts to migratory birds. INITIAL: Swallows and other bird species protected by the Migratory Bird Treaty Act (MBTA) may be nesting under bridges or other structures that may be impacted during this project. To comply with the MBTA, nests of protected species cannot be disturbed when active (eggs or young are present). Generally, nests are active between April 1 and July 31, but active nests can be present outside of these dates.

LPA Action: COMPLETE Confirm if any bridges or other structures (large box culverts, etc.) will be impacted by project activities. If so, assess the structures for the presence of migratory birds/nests under the structure prior to construction. Provide photos of the underside of the structure and include an explanation as to whether there are nests and/or unusual staining under the structure. Upload to RER with remaining TE species documentation. If no structures will be impacted by project activities, inform the environmental specialist.

Attachments:

Migratory Birds Submitted - Mark submitted when this review is ready to be sent to district staff.

Last Updated: Kyleen Kelly - 3/8/2021 9:05:55 AM

▶ Hazardous Waste Impact

Status Information: N/A Pending Cleared Clearance Date:

Environmental Response: According to the attached DNR E-START map, there are no Hazardous Substance Investigation and Cleanup Sites and no Regulated Petroleum and Hazardous Substance Storage Tank Facilities in the vicinity of the project area. There are no hazardous waste site concerns based on this information. However, the potential to encounter hazardous wastes from sites unknown to the LPA and MoDOT should always be a consideration.

LPA Action: Any hazardous waste sites that are found during project construction will be addressed by the LPA sponsor in accordance with Federal and State Laws and Regulations. If any hazardous waste concerns arise, notify MoDOT's environmental specialist as soon as possible. If there is any hydroblasting, grooving, milling or diamond grinding related to the project, residue and associated water must be prevented from being released to waterways or adjacent wetlands.

Attachments:

 [ESTART_RueStDenis.JPG](#)

Hazardous Waste Impact Submitted - *Mark submitted when this review is ready to be sent to district staff.*
Last Updated: Kyleen Kelly - 2/15/2021 8:49:23 AM

▶ Wetland Impact (Section 404/401)

Status Information: N/A Pending Cleared Clearance Date:

Environmental Response: According to the attached USFWS National Wetlands Inventory map, and Google Earth imagery, there are no wetlands, blue line streams, lakes, ponds, or other waters of the U.S. in or around the project area. The project is not anticipated to impact wetlands or waters of the U.S.

LPA Action: None

Wetland Permit Information:	404 Permit Number	Permit Submitted	Permit Received
	Permit Expiration	Compliance Certification Sent	Compliance Certification Received

Attachments:

 [NWI_RueStDenis.pdf](#)

Wetland Impact Submitted - *Mark submitted when this review is ready to be sent to district staff.*
Last Updated: Kyleen Kelly - 2/15/2021 8:49:36 AM

▶ Noise Impact

Status Information: N/A Pending Cleared Clearance Date:

Environmental Response: This is a Type III project and a noise analysis is not required.

LPA Action: None

Attachments:

Noise Impact Submitted - *Mark submitted when this review is ready to be sent to district staff.*
Last Updated: Kyleen Kelly - 2/15/2021 8:49:46 AM

Cultural Resources Impact (Section 106/Historic 4f)

Status Information: Pending Cleared Clearance Date: 10/04/2021

Environmental Response: UPDATE 10/5/2021: On October 4, 2021, SHPO again concurred with a determination of No Adverse Effect (SHPO Project No. 122-SL-21) so long as the repaired brickwork meets the pattern of the existing brickwork. FHWA again affirms that based upon the minimal use by the project on Casa Alvarez, the Archambault House, and the St. Ferdinand Central Historic District, the de minimis impact criteria has been met for this historic property. UPDATE 9/8/2021: Based on the new ROW plans, an updated submission to SHPO is required. Please prepare a letter addressing the changes and submit to MoDOT for review before submitting to SHPO. UPDATE 8/10/2021: On August 5, 2021, SHPO provided a determination of No Adverse Effect (SHPO Project No. 122-SL-21). Consultation between the Federal Highway Administration (FHWA), the Missouri Department of Transportation, the City of Florissant, and the State Historic Preservation Office (SHPO) has determined that the proposed project will have no adverse effect upon Casa Alvarez (a significant example of Missouri French Colonial architecture), the Archambault House (a significant example of Federal-style architecture), and the St. Ferdinand Central Historic District, which are listed in the National Register of Historic Places under the Historic Resources of the City of St. Ferdinand, Florissant, St. Louis County, MRA. SHPO has been notified that concurrence with the determinations of "no historic properties adversely affected" will be used by FHWA in applying the de minimis impact criteria for Historic Sites in compliance with Section 4(f) (49 U.S.C. 303). Based upon the minimal use by the project on Casa Alvarez, the Archambault House, and the St. Ferdinand Central Historic District, FHWA has determined that the de minimis impact criteria has been met for this historic property. Initial Response: The project requires a Section 106 Review in consultation with MoDOT, the City of Florissant, and the State Historic Preservation Officer (SHPO) for identifying potential cultural resources that may be impacted by the project.

LPA Action: UPDATE 10/5/2021: To ensure compliance with SHPO's conditions for no adverse effect for the project, please provide MoDOT's historic preservation staff with a copy of the draft and executed contract so we can ensure it includes a JSP to address the brickwork at the Archambault House per the SHPO letter. Be advised that if changes are made to the project (including but not limited to the addition of new right of way or easements, or the changing of the scope) the project will need to be reevaluated and additional clearances may be required. UPDATE 8/10/2021: Be advised that if changes are made to the project (including but not limited to the addition of new right of way or easements, or the changing of the scope) the project will need to be reevaluated and additional clearances may be required. Initial Response: Upload a completed draft of the attached Section 106 Project Information Form, including associated documentation, to the RER for review and comment by MoDOT's Historic Preservation staff. The environmental specialist will relay any comments for inclusion into the documentation. Once documentation is revised, if necessary, upload it to the RER as "Final Section 106 Documentation". The LPA sponsor may then submit it to the SHPO. Upload the SHPO response once received. The area of potential effects (APE) for the built environment should be defined as a 50 ft buffer surrounding any areas of new right of way or easement. The project area passes through the National Register-listed St. Ferdinand Central Historic District and near the National Register-listed Casa Alvarez and Archambault House. The Project Information Form should clearly explain the proposed project's potential effects to these historic resources, including impacts associated with any new ROW or easements and impacts to any potentially significant landscape features (historic curbs, sidewalks, etc.) if such are present. Please be sure to include thorough photographic coverage of the entire project area and any additional buildings 45 years or older that fall within the APE. Any such buildings located outside the historic district will need to be individually assessed for eligibility, and an assessment of effects provided for any other resources recommended eligible. The following information should be included regarding archaeological resources: The current project plans include roadway improvements (HMA overlay, sewer installation, sidewalk replacement, and curb/gutter installation) along Rue Saint Denis St, between Lafayette St. and Ferdinand St. in Florissant, St. Louis County. There is no additional right-of-way (ROW) or easement (permanent or temporary) currently identified for the project. Additional ROW may be needed but has not been identified yet. The project will involve more than 1 acre of land disturbance, but no tree clearing is anticipated. There are no prior archaeological investigations or previously recorded archaeological sites within or adjacent to the current project area. Overall, it appears that the project will be within existing disturbed land along Rue Saint Denis St. that would have a low potential for intact archaeological deposits. Therefore, if no previously undisturbed land will be affected by the project, no archaeological survey is recommended. A cover letter should accompany the Project Information Form. Assuming the project will result in no adverse effects, the letter should state: It is the City of Florissant's opinion that no historic properties will be adversely affected by the above reference project and that it should proceed as planned with no additional Section 106 work. We request the concurrence of the State Historic Preservation Office (SHPO) with this finding. We are also notifying SHPO that concurrence with determinations of "no historic properties affected" or "no historic properties adversely affected" may be used by the Federal Highway Administration in applying the de minimis impact criteria for Historic Sites in compliance with Section 4(f) (49 U.S.C. 303). Please be sure to provide the cover letter, Project Information Form, and all associated attachments for MoDOT review before you submit to SHPO.

Attachments:

- [St. Louis, St. Denis Street_STP 5622\(602\)_Section 106_Admin_Rec.pdf](#)
- [Section 106 Project Information Form_1-20.pdf](#)

Adverse Effect or Conditional No Adverse Effect

Based on the review of the project location and description noted above, there are no identified historic 4(f) resources affected that would preclude the setting of an A-date.

Checked by: on de minimis

Cultural Resources Impact Submitted - Mark submitted when this review is ready to be sent to district staff.

Last Updated: Alyssa Reynolds - 10/5/2021 4:21:45 PM

Public Land Impact (Section 4f/6f)

Status Information: N/A Pending Cleared Clearance Date:

Environmental Response: UPDATE 6/22/2021: Consultant has provided a memo confirming that no ROW or easements will be taken from the public park adjacent to the project area, and access to the park will not be restricted during construction activities. The project will not result in the use of Section 4(f) resources or the conversion of any Section 6(f) lands. INITIAL: According to Google Earth imagery and ArcMap GIS public lands layers, Spanish Land Grant Park (adjacent to the project area to the northwest), Coldwater Commons Park (0.15-mile west), St. Ferdinand Park (0.28-mile north), Chapman Florval Park (0.53-mile north), and Little Woods Park (0.42-mile northeast) are in the vicinity of the project area. However, the project does not appear to require new right of way or easements from and will not restrict access to these resources. The sponsor should confirm this information.

LPA Action: COMPLETE Please confirm whether or not any ROW or easements will be taken from the public park adjacent to the project area (Spanish Land Grant Park), and whether any restriction in access to this park is anticipated.

Attachments:

Based on the review of the project location and description noted above, there are no identified 4(f) or 6(f) resources affected that would preclude the setting of an A-date.

Checked by: on

Public Land Impact Submitted - Mark submitted when this review is ready to be sent to district staff.
Last Updated: Kyleen Kelly - 6/22/2021 1:14:56 PM

Other

Status Information: N/A Pending Cleared Clearance Date:

Environmental Response: The project is within 4 miles of Lambert-St. Louis International Airport, an existing public use airport.

LPA Action: Access FAA's Notice Criteria Tool at: <https://oeaaa.faa.gov/oeaaa/external/gisTools/gisAction.jsp?action=showNoNoticeRequiredToolForm> After entering improvement information into the FAA tool, filing information will be determined with one of two outcomes: (1) the improvement will need to be filed with the FAA, or (2) the improvement does not meet the FAA's filing requirement and no further action is required. Upload all documentation to the RER. This section does not have to be complete to obtain a NEPA date or A-date but must be completed before the environmental specialist issues All Environmental Issues Cleared.

Attachments:

Other Screening Submitted - Mark submitted when this review is ready to be sent to district staff.
Last Updated: Kyleen Kelly - 2/15/2021 8:59:09 AM

NEPA Classification

NEPA Right-Of-Way Permission: Can Proceed to Buy R/W as determined or approved by: Melissa.Scheperle@modot.mo.gov
NEPA Approval/Proceed to A-date Request: 10/07/2021 Re-evaluation Date:

NEPA Classification: PCE
This project qualifies for the programmatic categorical exclusion under Item#: 26 All Environmental Issues Cleared:

Commitments and/or Comments to Sponsor: UPDATE 10/7/2021: This project qualifies for a PCE NEPA classification. If there are any changes in the scope of the project, the Environmental Section should review those changes, as a re-evaluation of resources may be required. The sponsor is ultimately responsible for complying with all applicable state and federal laws. INITIAL: The NEPA classification and approval date will be given once the Cultural Resources, Threatened & Endangered Species, and Public Lands sections are cleared. THE LPA/CONSULTANT SHOULD REVIEW ALL SECTIONS ABOVE INCLUDING THOSE MARKED AS CLEARED/GREEN.

Attachments:

PCE NEPA
[Concurrence_10.7.2021.pdf](#)

Last Submitted: 10/07/2021 by Kyleen Kelly

RIGHT OF WAY CLEARANCE CERTIFICATION



City of Florissant

Honorable Timothy J. Lowery; Mayor

CONDITIONAL RIGHT OF WAY CLEARANCE CERTIFICATION STATEMENT

DATE: March 15, 2024

TO: Janelle Lemon
MoDOT Right of Way Consultant
3050 West Clay Street, Suite 200
St. Charles, MO 63301

FROM: Tom Goldkamp, City Engineer for City of Florissant

RE: Rue St. Denis – Phase 1 Road Improvements
City of Florissant, Missouri
Federal Project No. STP-5622(602)

**Mendy
Sunder
meyer**

Digitally signed
by Mendy
Sundermeyer
Date: 2024.04.05
13:22:15 -05'00'

SUBJECT: Right of Way Clearance Certification

<u>10/7/2021</u>	Date of NEPA Clearance
<u>Entire</u>	Entire Project or Partial Clearance
<u>City of Florissant</u>	Name of Sponsor
<u>Rue St. Denis Phase 1</u>	Road or Project Name
<u>STP-5622(602)</u>	Federal Project Number
<u>11+23.21 to 28+93.30</u>	Termini of the Rue St. Denis Portion
<u>1+80.00 to 6+27.39</u>	Termini of the Jefferson Street Portion

The above referenced city/county certifies the following: (Make all of the statements depending upon type of acquisitions involved for project.)

- X A. Right of Way Required - No Personal Property Moved - No Relocation Assistance Required
1. We certify that all necessary right of way, easements and access rights have been acquired in accordance with the Titles 49 and 23 CFR.
 2. Legal and physical possession of all parcels has been obtained.
 3. The steps relative to relocation advisory assistance and payments were not required.
- B. Right of Way Required - Personal Property Moved - No Occupied Improvements Acquired
1. We certify that all necessary right of way, easements and access rights have been acquired in accordance with Titles 49 and 23 CFR.



City of Florissant

Honorable **Timothy J. Lowery**; Mayor

2. Legal and physical possession of all parcels has been obtained.
3. Steps relative to relocation advisory assistance and payments as required by 49 CFR, Part 24 have been taken (personal property moved only).

_____ C. Right of Way Required - Personal Property Moved - Occupied Improvements Acquired (If C applies or is checked, please fill out form 136.8.8a.

1. We certify that all necessary right of way, easements and access rights have been acquired in accordance with Titles 49 and 23 CFR.
2. Legal and physical possession of all parcels has been obtained.
3. Steps relative to relocation advisory assistance and payments as required by 49 CFR, Part 24 have been taken.
4. All individuals and families have been relocated to or offered equivalent decent, safe and sanitary housing in accordance with 49 CFR, Part 24.

The City of Florissant received conditional clearance for 15 of the 35 parcels on August 22, 2023. The following parcels were signed, submitted, reviewed and approved for the conditional clearance: 8, 9, 12, 17, 23, 24, 25, 26, 28, 29, 30, 32, 34, 39, 42

Parcel Acquisition Detail:

There were 35 parcels on this project that required the acquisition of right of way, easements and/or access rights.

There were 34 parcels acquired by negotiation.

There were 3 parcels acquired by donation.

There were 0 parcels that were acquired by condemnation.

There were 10 parcels settled administratively for an amount other than the approved offer.

There were 0 parcels that were appraised and subsequently voided and not acquired.

There was 1 parcel that was deleted from the project, if any.

Responsibility of Parcel Acquisition:

There were _____ parcels that were acquired by MoDOT personnel.

There were _____ parcels that were acquired by Local Public Agency personnel.

There were 34 parcels that were acquired by Contract Negotiator(s) on the MoDOT Roster.



City of Florissant

Honorable **Timothy J. Lowery**; Mayor

Expenditure Detail

There was \$48,610.00 spent on total Acquisition of land, realty rights, and improvements.

The Right of Way Manager in your District will review the parcel acquisition files and submit this certification to Right of Way Central Office for final approval.

DELETED PARCEL

Parcel 5 - We were unable to obtain the temporary easement from the current owner. It was determined that the work could be completed on the existing right of way.

Tom Goldkamp

LPA Agency Signature

3-15-24

Date

LAND DISTURBANCE PERMIT INFORMATION

LAND DISTURBANCE APPLICATION



City of Florissant

Engineering Division
955 Rue St. Francois
Florissant, Missouri 63031
(314) 839-7643

Location of Work _____

Owner's Information

Name _____

Telephone _____

Address, State, Zip _____

Emergency Telephone _____

Email _____ Fax _____

Contractor's Information

Name _____

Telephone _____

Address, State, Zip _____

Emergency Telephone _____

Email _____ Fax _____

Engineer's Information

Name _____

Telephone _____

Address, State, Zip _____

Emergency Telephone _____

Email _____ Fax _____

Number of Acres Disturbed _____

Proposed Work Description _____

I hereby certify that the proposed work is authorized by the owner of record and that I have been authorized by the owner to make this application as his agent, and we agree to conform to all applicable laws.

Name (Please Print) _____

Signature of Applicant _____ **Date** _____

Notify the City Engineer's office within two working days prior to commencing any land disturbing or land development activity.

MAJOR LAND DISTURBANCE CHECKLIST

SITE ADDRESS:

DATE:

1. COMPLETED LAND DISTURBANCE PERMIT APPLICATION

2. STORM WATER POLLUTION PREVENTION PLAN (SWPPP)

The Storm Water Pollution Prevention Plan and the plan shall include the following:

1. Name, address and telephone number of the site owner and the name, address and telephone number of the individual who will be in overall responsible charge of construction/development activities at the site.
2. Site address or location description and parcel identification number(s).
3. A site map showing the outlines of the total project area, the areas to be disturbed, existing land uses, locations and names of surface water bodies, locations of flood plains, locations of temporary and permanent Best Management Practices (BMP) and such other information as may be required by the department(s) having enforcement authority and responsibilities described in section 505.106 of this Code.
4. Existing contours of the site and adjoining strips of off-site property and proposed contours after completion of the proposed land disturbance and development, based on United States Geological Survey datum, with established elevations at buildings, walks, drives, street and roads; and information on necessary clearing and grubbing, removal of existing structures, excavating, filling, spreading and compacting.
5. A natural resources map identifying soils, forest cover, and resources protected under other provisions of City Ordinances.
6. An estimate of the Runoff Coefficient of the site prior to disturbance and the Runoff Coefficient after the construction addressed in the permit application is completed.
7. Estimated quantity of land to be disturbed.
8. Details of the site drainage pattern both before and after Major Land Disturbance Activities.
9. Access to construction site.
10. Description of Best Management Practices (BMP) to be utilized to control erosion and sedimentation during the period of land disturbance.
11. Description of Best Management Practices (BMP) to be utilized to prevent other potential pollutants such as construction wastes, toxic or hazardous substances, petroleum products, pesticides, herbicides, site litter, sanitary wastes and other pollutants from entering the natural drainage ways during the period of construction and land disturbance.
12. Description of Best Management Practices (BMP) that will be installed during land disturbance to control pollutants in storm water discharges that will occur after land disturbance activity has been completed.
13. Location of temporary off-street parking, and wash down area for related vehicles.
14. Sources of offsite borrow material or spoil sites, and all information relative to haul routes, trucks and equipment.

15. The anticipated sequence of construction and Land Disturbance Activities, including installation of Best Management Practices (BMP), removal of temporary Best Management Practices (BMP), stripping and clearing; rough grading; construction utilities, infrastructure, and buildings; and final grading and landscaping. Sequencing shall identify the expected date(s) on which clearing will begin, the estimated duration of exposure of cleared areas, areas of clearing, installation of temporary erosion and sediment control measures, and establishment of permanent vegetation.

16. All erosion and sediment control measures necessary to meet the objectives of this Code throughout all phases of construction and after completion of site development. Depending upon the complexity of the project, the drafting of intermediate plans may be required at the close of each season.

17. Seeding mixtures and rates, types of sod, method of seedbed preparation, expected seeding dates, type and rate of lime and fertilizer application, and kind and quantity of mulching for both temporary and permanent vegetative control measures.

18. Provisions for maintenance of control facilities, including easements and estimates of the cost of maintenance.

19. Plans for responding to any loss of contained sediment to include the immediate actions the permit-holder will take in case of a containment failure. This plan must include documentation of actions and mandatory reporting to the Department of Public Works.

20. Schedules and procedures for routine inspections of any structures provided to prevent pollution of storm water or to remove pollutants from storm water and of the site in general to ensure all Best Management Practices (BMP) are continually implemented and are effective.

3. COST ESTIMATE FOR SITE IMPROVEMENTS

The cost estimate shall include, at a minimum, all site development work and erosion control measures, along with maintenance and inspection costs anticipated until such time that the site has been fully stabilized.

4. SITE DEVELOPMENT ESCROW

Applicants for major land disturbance permits shall file a site development escrow in the form of a letter of credit or other improvement security in an amount deemed sufficient by the Department of Public Works to cover all costs of improvements, landscaping and maintenance of improvements for such period as specified by the Department of Public Works. The site development escrow shall include engineering and inspection costs sufficient to cover the cost of failure or repair of improvements installed on the site.

5. STATE LAND DISTURBANCE PERMIT FROM THE MISSOURI DEPARTMENT OF NATURAL RESOURCES

6. PERMIT FEE OF \$500.00

May be in the form of cash, check, money order or debit. Credit cards not accepted.

CONTRACT FORMS

3. Form to be used if Contractor is a corporation

State of _____)
County of _____) ss.

On this _____ day of _____, 20 _____, before me appeared _____, to me personally known, who being by me duly sworn, did say that he/she is the _____ of _____ (the Contractor) and that the seal affixed to the foregoing agreement and contract bond is the corporate seal of said corporation, and that the foregoing proposal, contract agreement, and contract bond were signed and sealed in behalf of said corporation by authority of its board of directors, and he/she acknowledges said instruments to be the free act and deed of said corporation.

Witness my hand and seal at _____, _____, the day and year first above written.

(SEAL)

Notary Public

My commission expires _____, 20 _____.

CONTRACT AGREEMENT

THIS AGREEMENT, made and entered into by and between the state of Missouri, acting by and through the Missouri Highway and Transportation Commission, hereinafter referred to as Commission, and _____ of _____ hereinafter referred to as Contractor.

WITNESSETH:

That for and in consideration of the acceptance of Contractor's bid and the award of this contract to said Contractor by the Commission, and in further consideration of the agreement of the parties herein contained, to be well and truly observed and faithfully kept by them and each of them, it is agreed as follows:

The Contractor hereby agrees to do or furnish at his/her own expense all labor, materials and equipment called for in the proposal designated and marked, "Proposal for Filling Basements and/or Foundations," on Route _____, Project _____, _____ County, Missouri, as provided for in the specifications pertaining to said work.

It is understood and agreed that all work shall be done in accordance with the specifications pertaining thereto, and that said specifications are made a part hereof as though fully set out in detail herein.

The Contractor agrees that he/she is fully informed regarding all the conditions affecting the work to be done and the labor and materials to be furnished for the completion of this contract and that his/her information was secured by personal investigation and not from any estimates of Commission and that he/she will make no claim against the state or Commission by reason of any representation of any officer, agent or employee of the Commission, other than the provisions contained in the specifications.

Work shall be done under the direct supervision and to the complete satisfaction of the District Engineer for the Commission.

The Contractor expressly warrants that he/she has employed no third person to solicit or obtain this contract in his/her behalf, or to cause or procure the same to be obtained upon compensation in any way contingent, in whole or in part, upon such procurement; and that he/she has not paid, or promised or agreed to pay, to any third person, in consideration of such procurement, or in compensation for services in connection therewith, any brokerage, Commission or percentage upon the amount receivable by him/her hereunder; and that he/she has not, in estimating the contract price demanded by him/her, included any sum by reason of any such brokerage, Commission or percentage; and that all monies payable to him/her hereunder are free from obligation of any other person for services rendered, or supposed to have been rendered, in the procurement of this contract.

He/she further agrees that any breach of this warranty shall constitute adequate cause for the annulment of this contract by the Commission, and that the Commission may retain to its own use from any sums due or to become due hereunder an amount equal to any brokerage or Commission so paid or agreed to be paid.

The parties hereto agree that the contract in all things shall be governed by the laws of the state of Missouri.

The Commission agrees to pay the Contractor in the manner and in the amount provided in the specifications and proposal.

IN WITNESS WHEREOF, the parties hereto have hereunto set their hands this _____ day of _____, 20____.

THE STATE OF MISSOURI, acting by and through
MISSOURI HIGHWAY AND TRANSPORTATION
COMMISSION

By _____

Contractor

By _____

NOTE: Current wage rate information should be attached to this contract.

CONTRACT BOND

KNOW ALL MEN BY THESE PRESENTS: That we _____

as principle, and _____

as surety, are held and firmly bound unto the State of Missouri in the penal sum of: _____

DOLLARS (\$ _____) as the same may be increased by any and all changes in or additions to said contract which may hereafter be made, lawful money of the United States, to be paid to the said State of Missouri or to its certain agents, attorneys, assigns, or to the Missouri Highways and Transportation Commission, for which sums of money, well and truly to be paid, we bind ourselves, our heirs, successors, assigns, executors, and administrators, jointly and severally, firmly by these presents.

SEALED with our seals and dated _____

The condition of this obligation is such that

WHEREAS, the said bounden principal has entered into a certain contract with the State of Missouri acting by and through the Missouri Highways and Transportation Commission, said contract being marked.

Route:

County:

Job No.:

a copy of said contract being hereto attached and made a part hereof and bearing date of _____

NOW, THEREFORE, if the said principal shall comply with and fulfill all the conditions of said contract, including those under which principal agrees to pay the prevailing hourly rate of wages for each craft or type of workman required to execute the contract in the locality as determined by State and Federal authority, as applicable, or by final judicial determination, and properly and promptly complete the work in accordance with the provisions of said contract, plans and specifications without any hidden defects, and furnish all the labor and materials required by said contract, and any and all changes in, or additions to said contract, which may hereafter be made, and shall perform all the undertakings stipulated by said bounden principal to be performed and within the time mentioned in said

Design Form C-3

Call

contract, or within any additional time granted by the Missouri Highway and Transportation Commission or its Chief Engineer, under authority from said Commission of Missouri, which may be granted without notice to or consent from the surety, and shall pay for all materials, lubricants, fuel, coal and coke, repairs on machinery, groceries and foodstuff, equipment and tools consumed or used in connection with the construction of such work, and all insurance premiums, both compensation, and all other kinds of insurance, on said work, and for all labor performed in such work, whether by subcontractor or claimant in person or by its employee, agent, servant, bailee, or bailor, then this to be void; otherwise it shall be and remain in full force and effect.

ATTEST: (SEAL)

Secretary

Principal

By _____

Title _____

Surety

ATTEST: (SEAL)

By _____

Title _____

Address – Agent or Broker

Street

City

Name and Street Address of Agent to Whom All
Correspondence Should be Directed Relating to
Contract and Bond.

Name

Street

City, State