

Alternate detail for Type H barrier

Standard Drawing Guidance  
(do not show on plans):

- ① Remove if not required.
- ② Use the following values for clearance to top longitudinal bars:  
3/8" for #5 bars  
3" for #6 bars  
2 7/8" for #7 bars  
2 3/4" for #8 bars

Use a triple asterisk when there are different size top bars and add below the single asterisk note the following (modified as needed) (this will be the only asterisk note for CIP decks):

- \*\*\* 3 1/8" (#5)
- 3" (#5)
- 2 7/8" (#7)
- 2 3/4" (#8)

Clearance value based on the #6 top transverse bar used for this standard slab. Values will need to be revised for other size transverse bars.

- ③ The larger negative moment reinforcement shown is grouped and can be deleted if the negative moment steel is the same size as the distribution reinforcement. A set of bars the same size as the distribution bars exist behind the larger bars shown, and will become visible when the larger bars are deleted. (No need to resize)
- ④ The subheadings and negative moment bars are grouped and can be deleted for single span bridges. <Ctrl> U to ungroup.

- ⑤ Place appropriate slab pouring sequence cell and modify as required.
- ⑥ Use alternate detail for CIP decks:

- ⑦ Remove for CIP deck

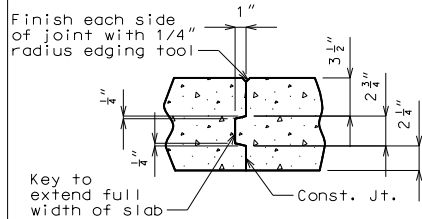

SLAB CONSTRUCTION JOINT

- ⑦ Remove for CIP deck

Girder spacing and reinforcement size & spacing shown are not necessarily standard. Follow design.

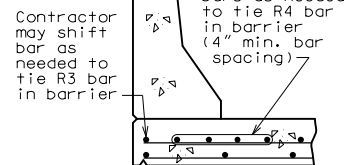

OPTIONAL SHIFTING TOP BARS AT BARRIER

SLAB10\_44ft\_symm Effective: Apr. 2020 Supersedes: June 2016

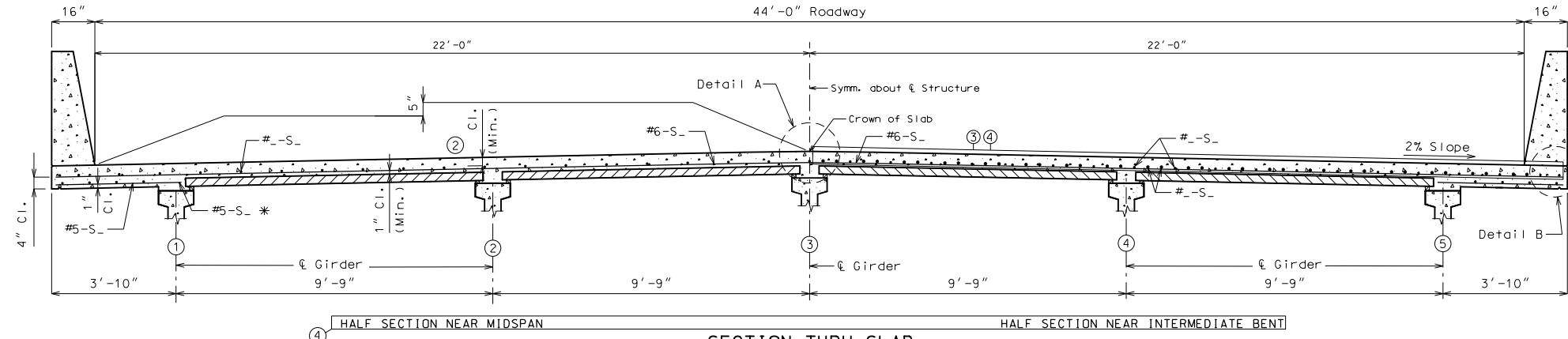

SECTION THRU SLAB

\* Alternate bar shape available, see barrier sheet.

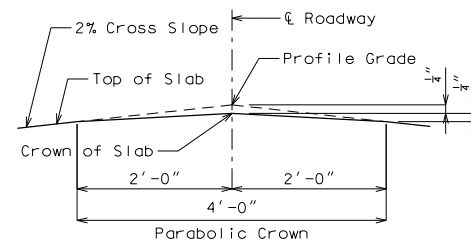

DETAIL A

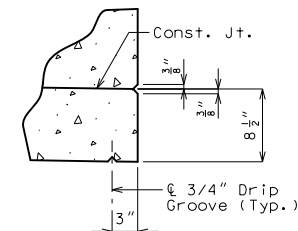

DETAIL B

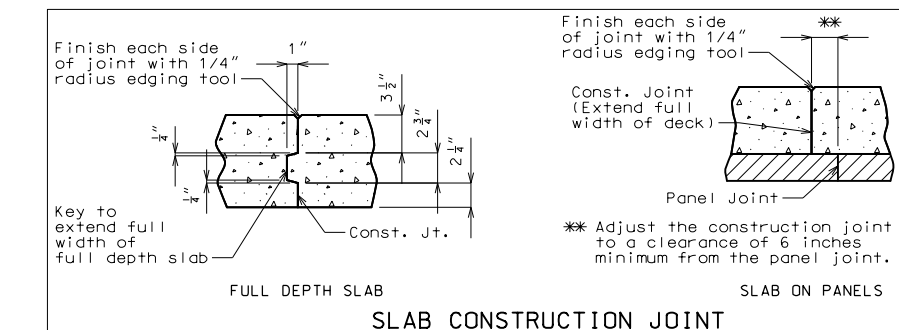
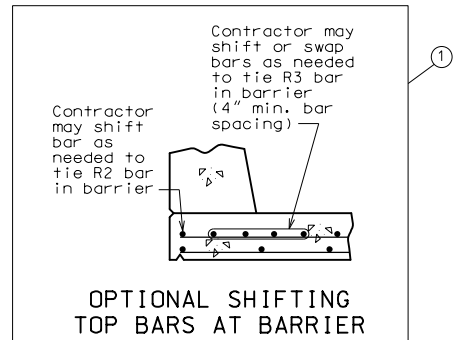

Notes:

- ⑦ For details of precast prestressed panels, see Sheet No. .

For reinforcement of barrier not shown, see Sheet No. .

For Theoretical Bottom of Slab Elevations, Girder Camber Diagram and Theoretical Slab Haunching Diagram, see Sheet No. .

For Plan of Slab Showing Reinforcement, see Sheet No. .

Detailed Checked

Note: This drawing is not to scale. Follow dimensions.

SLAB DETAILS

Sheet No. of

"THIS MEDIA SHOULD NOT BE CONSIDERED A CERTIFIED DOCUMENT."

DATE PREPARED  
5/4/2020

ROUTE STATE  
\* MO

DISTRICT SHEET NO.  
BR \*

COUNTY \*

JOB NO. \*

CONTRACT ID. \*

PROJECT NO.

BRIDGE NO.  
SLAB10

DESCRIPTION

DATE

MISSION HIGHWAYS AND TRANSPORTATION COMMISSION

MISSOURI HIGHWAYS AND TRANSPORTATION COMMISSION

105 WEST CAPITOL

JEFFERSON CITY, MO 65102

1-888-ASK-MODOT (1-888-275-6636)

IF A SEAL IS PRESENT ON THIS SHEET IT HAS BEEN ELECTRONICALLY SEALED AND DATED.

MISSOURI HIGHWAYS AND TRANSPORTATION COMMISSION

MISSOURI HIGHWAYS AND TRANSPORTATION COMMISSION

MISSOURI HIGHWAYS AND TRANSPORTATION COMMISSION

MISSOURI HIGHWAYS AND TRANSPORTATION COMMISSION

MISSOURI HIGHWAYS AND TRANSPORTATION COMMISSION

MISSOURI HIGHWAYS AND TRANSPORTATION COMMISSION

MISSOURI HIGHWAYS AND TRANSPORTATION COMMISSION

MISSOURI HIGHWAYS AND TRANSPORTATION COMMISSION

MISSOURI HIGHWAYS AND TRANSPORTATION COMMISSION

MISSOURI HIGHWAYS AND TRANSPORTATION COMMISSION

MISSOURI HIGHWAYS AND TRANSPORTATION COMMISSION

MISSOURI HIGHWAYS AND TRANSPORTATION COMMISSION

MISSOURI HIGHWAYS AND TRANSPORTATION COMMISSION

MISSOURI HIGHWAYS AND TRANSPORTATION COMMISSION

MISSOURI HIGHWAYS AND TRANSPORTATION COMMISSION

MISSOURI HIGHWAYS AND TRANSPORTATION COMMISSION

MISSOURI HIGHWAYS AND TRANSPORTATION COMMISSION

MISSOURI HIGHWAYS AND TRANSPORTATION COMMISSION

MISSOURI HIGHWAYS AND TRANSPORTATION COMMISSION

MISSOURI HIGHWAYS AND TRANSPORTATION COMMISSION

MISSOURI HIGHWAYS AND TRANSPORTATION COMMISSION

MISSOURI HIGHWAYS AND TRANSPORTATION COMMISSION

MISSOURI HIGHWAYS AND TRANSPORTATION COMMISSION

MISSOURI HIGHWAYS AND TRANSPORTATION COMMISSION

MISSOURI HIGHWAYS AND TRANSPORTATION COMMISSION

MISSOURI HIGHWAYS AND TRANSPORTATION COMMISSION

MISSOURI HIGHWAYS AND TRANSPORTATION COMMISSION

MISSOURI HIGHWAYS AND TRANSPORTATION COMMISSION

MISSOURI HIGHWAYS AND TRANSPORTATION COMMISSION

MISSOURI HIGHWAYS AND TRANSPORTATION COMMISSION

MISSOURI HIGHWAYS AND TRANSPORTATION COMMISSION

MISSOURI HIGHWAYS AND TRANSPORTATION COMMISSION

MISSOURI HIGHWAYS AND TRANSPORTATION COMMISSION

MISSOURI HIGHWAYS AND TRANSPORTATION COMMISSION

MISSOURI HIGHWAYS AND TRANSPORTATION COMMISSION

MISSOURI HIGHWAYS AND TRANSPORTATION COMMISSION

MISSOURI HIGHWAYS AND TRANSPORTATION COMMISSION

MISSOURI HIGHWAYS AND TRANSPORTATION COMMISSION

MISSOURI HIGHWAYS AND TRANSPORTATION COMMISSION

MISSOURI HIGHWAYS AND TRANSPORTATION COMMISSION

MISSOURI HIGHWAYS AND TRANSPORTATION COMMISSION

MISSOURI HIGHWAYS AND TRANSPORTATION COMMISSION

MISSOURI HIGHWAYS AND TRANSPORTATION COMMISSION

MISSOURI HIGHWAYS AND TRANSPORTATION COMMISSION

MISSOURI HIGHWAYS AND TRANSPORTATION COMMISSION

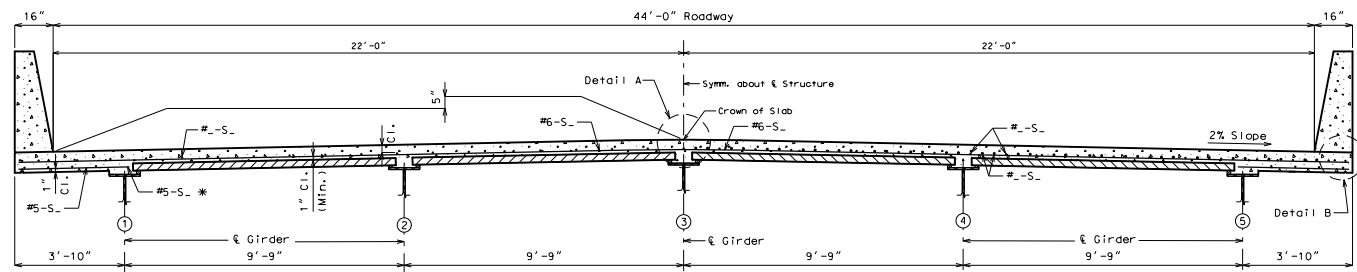

HALF SECTION NEAR MIDSPAN SECTION THRU SLAB HALF SECTION NEAR INTERMEDIATE BENT

\* Alternate bar shape available, see barrier sheet.

Plate Girder w/ Panel (5 Girder)

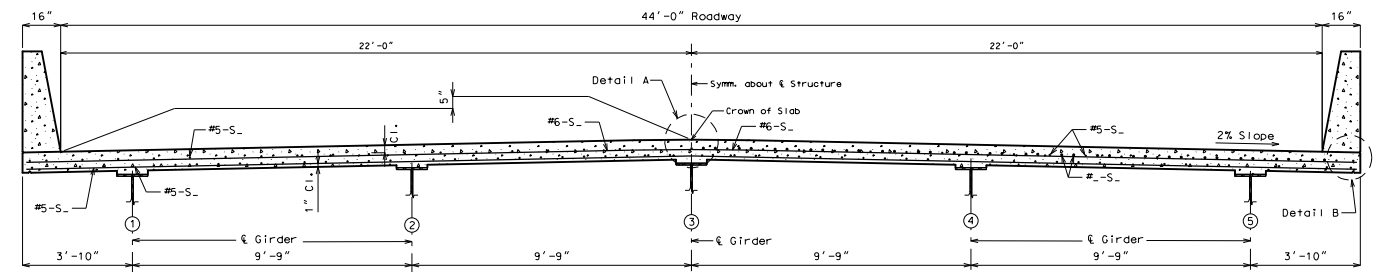

HALF SECTION NEAR MIDSPAN SECTION THRU SLAB HALF SECTION NEAR INTERMEDIATE BENT

\* Alternate bar shape available, see barrier sheet.

Plate Girder C.I.P. (5 Girder)

Type 2,3,4 w/ Panel (5 Girder)

Type 2,3,4 C.I.P. (5 Girder)

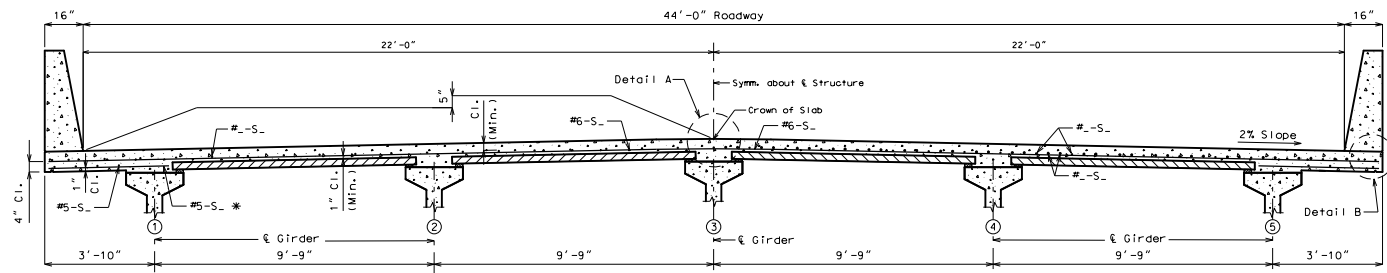

HALF SECTION NEAR MIDSPAN SECTION THRU SLAB HALF SECTION NEAR INTERMEDIATE BENT

\* Alternate bar shape available, see barrier sheet.

Type 6 w/ Panel (5 Girder)

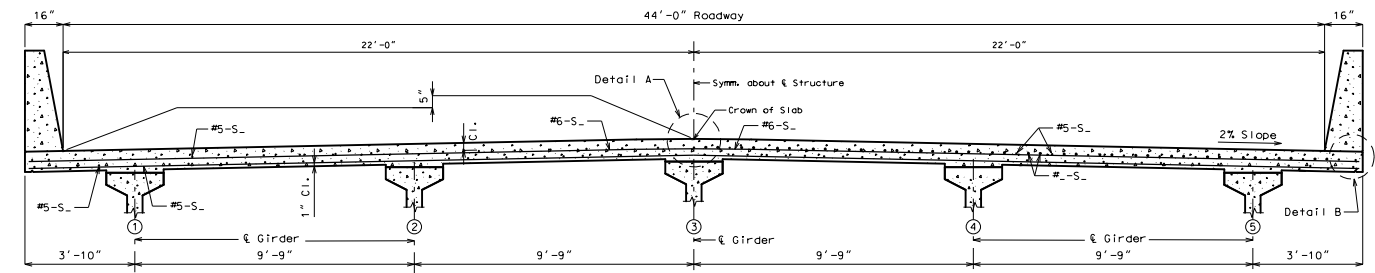

HALF SECTION NEAR MIDSPAN SECTION THRU SLAB HALF SECTION NEAR INTERMEDIATE BENT

\* Alternate bar shape available, see barrier sheet.

Type 6 C.I.P. (5 Girder)

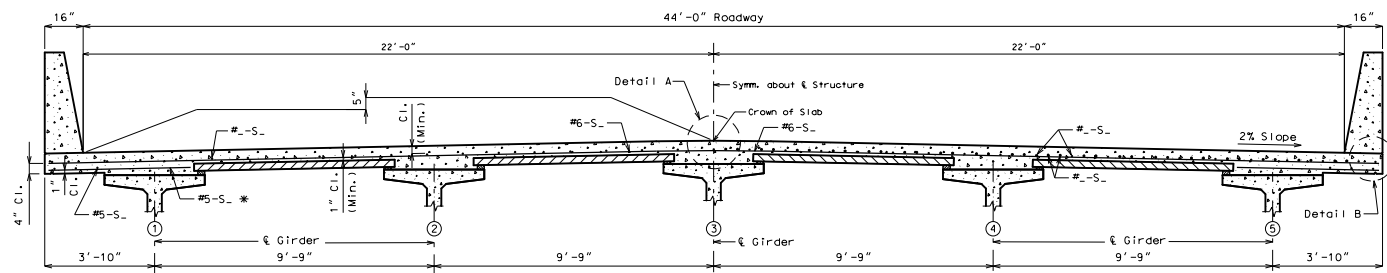

HALF SECTION NEAR MIDSPAN SECTION THRU SLAB HALF SECTION NEAR INTERMEDIATE BENT

\* Alternate bar shape available, see barrier sheet.

Bulb Tee w/ Panel (5 Girder)

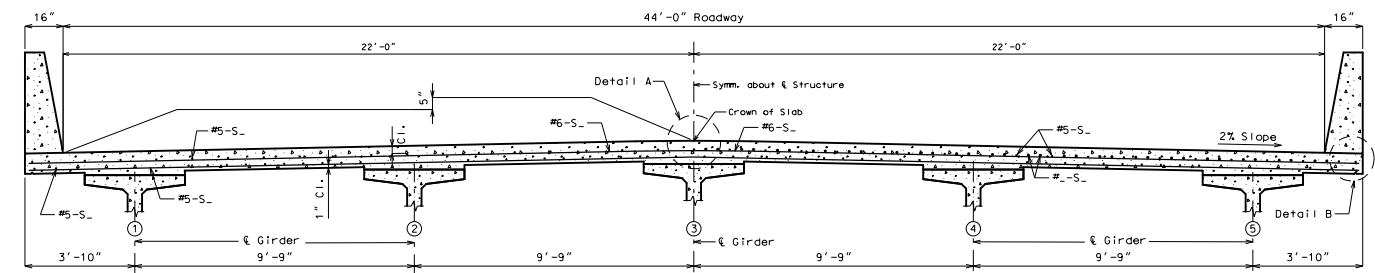

HALF SECTION NEAR MIDSPAN SECTION THRU SLAB HALF SECTION NEAR INTERMEDIATE BENT

\* Alternate bar shape available, see barrier sheet.

Bulb Tee C.I.P. (5 Girder)