

# **MISSOURI HIGHWAYS and TRANSPORTATION COMMISSION**

**JEFFERSON CITY, MISSOURI**

**SUPPLEMENTAL PLANS TO JULY 201J MISSOURI STANDARD  
PLANS FOR HIGHWAY CONSTRUCTION**

**EFFECTIVE CWcVYf 1, 2019**

# MISSOURI HIGHWAYS AND TRANSPORTATION COMMISSION

## MISSOURI STANDARD PLANS FOR HIGHWAY CONSTRUCTION

### TABLE OF CONTENTS

STANDARD NO.	DRAWING TITLE	NO. OF SHEETS	EFFECTIVE DATE	STANDARD NO.	DRAWING TITLE	NO. OF SHEETS	EFFECTIVE DATE
203.00E	EXCAVATION AND EMBANKMENT - TYPICAL DETAILS	1	08/01/1998	606.60B	MIDWEST GUARDRAIL SYSTEM (MGS) - VERTICAL BARRIER TRNSITIONS	6	04/01/2018
203.02F	UNDERGRADING - TYPICAL DETAILS	2	01/01/2004	606.70B	MIDWEST GUARDRAIL SYSTEM (MGS) - THRIE BEAM RAIL ON BRIDGE	5	04/01/2018
203.10D	TABULATED EARTHWORK AND SECTION DATA	1	02/01/2009	606.80C	MIDWEST GUARDRAIL SYSTEM (MGS) - TERMINAL ANCHOR ENDS	7	07/01/2017
203.20G	SUPERELEVATION, SPIRALS AND WIDENING (UNDIVIDED HIGHWAY)	4	07/01/2017	606.81B	MASH - CRASHWORTHY END TERMINALS - TYPE A - GRADING LIMITS *	1	10/01/2019
203.21K	SUPERELEVATION, SPIRALS AND WIDENING (DIVIDED HIGHWAY)	3	07/01/2017	607.10V	CHAIN-LINK FENCE	1	02/01/2007
203.22	SUPERELEVATION, SPIRALS AND WIDENING	2	07/01/2017	607.11H	CHAIN-LINK FENCE FOR RETAINING WALLS	1	06/01/2009
203.35A	MAILBOX TURNOUTS	1	08/01/1981	607.20G	WOVEN WIRE FENCE	2	07/01/2016
203.40G	TYPICAL DETAILS ON AND OFF RAMPS	2	10/01/2007	608.00H	PAVED APPROACHES	2	10/01/2009
203.41F	TYPICAL DETAILS ON AND OFF RAMPS (ROADWAY WITH 6:1 FORESLOPE)	2	01/01/1995	608.10P	CONCRETE SIDEWALK	1	04/01/2015
203.50N	TYPICAL MEDIAN OPENINGS (DIVIDED HIGHWAYS)	2	04/01/2016	608.20E	CONCRETE STAIRS	2	04/01/2015
203.61A	DRIVEWAY - TYPE I	1	07/01/2004	608.30A	CONCRETE MEDIAN STRIP	1	02/01/2011
203.62D	DRIVEWAY - TYPE II	2	04/01/2017	608.40	HANDRAILING	4	04/01/2015
203.63B	DRIVEWAY - TYPE III	2	04/01/2017	608.50	CURB RAMPS	4	04/01/2015
203.64D	DRIVEWAY - TYPE IV	2	04/01/2017	609.00P	CONCRETE CURB, CURB AND GUTTER AND GUTTER	2	08/01/2008
203.65A	DRIVEWAY - TYPE V	1	10/01/1998	609.15D	PAVED DITCHES	1	07/01/2016
204.00D	EMBANKMENT CONTROL - MEASURING DEVICES	1	04/01/1983	609.40S	DRAIN BASIN, SHOULDER PAVING AND FILL SLOPES AT BRIDGE ENDS	3	01/01/2017
204.30	PORE PRESSURE MEASUREMENT DEVICES	1	03/01/1996	609.60C	ROCK DITCH LINER	1	03/01/1993
401.00B	TYPE A2 AND A3 SHOULDERS, SAFETY EDGE <sup>SM</sup>	3	04/01/2018	609.70C	ROCK LINING FOR CULVERT OUTLET	1	10/01/1981
413.20	SCRUB SEAL BROOM CONFIGURATION	1	07/01/2004	611.60R	CONCRETE SLOPE PROTECTION	1	07/01/2015
502.05N	CONCRETE PAVEMENT AND BASE APPURTENANCES FOR 15 FT. JOINT SPACING	4	07/01/2015	612.20E	SAND FILLED IMPACT ATTENUATORS	1	10/01/2018
502.10K	DOWEL SUPPORTING UNITS	2	06/01/2010	613.00S	PAVEMENT REPAIR	4	04/01/2017
504.00J	CONCRETE APPROACH PAVEMENT	3	07/01/2015	614.10T	GRATES AND BEARING PLATES	1	12/01/2005
602.00D	RIGHT-OF-WAY AND DRAIN MARKERS	2	01/01/2003	614.11C	CURVED VANE GRATE AND FRAME	1	06/01/2010
604.05D	PIPE CULVERT HEADWALLS - TYPE S	2	08/01/2006	614.30E	MANHOLE FRAMES AND COVERS	2	03/01/1996
604.10E	PIPE CULVERT HEADWALL - ENERGY DISSIPATOR FOR 18" CONCRETE PIPE	1	07/01/2001	616.10AV	TEMPORARY TRAFFIC CONTROL DEVICES	9	07/01/2019
604.11E	PIPE CULVERT HEADWALL - ENERGY DISSIPATOR FOR 24" CONCRETE PIPE	1	07/01/2001	617.10L	PERMANENT CONCRETE TRAFFIC BARRIER	11	01/01/2019
604.12E	PIPE CULVERT HEADWALL - ENERGY DISSIPATOR FOR 30" CONCRETE PIPE	1	07/01/2001	617.20D	TEMPORARY CONCRETE TRAFFIC BARRIER	8	10/01/2018
604.13E	PIPE CULVERT HEADWALL - ENERGY DISSIPATOR FOR 36" CONCRETE PIPE	1	07/01/2001	619.10J	PAVEMENT EDGE TREATMENT	1	10/01/2017
604.14E	PIPE CULVERT HEADWALL - ENERGY DISSIPATOR FOR 42" CONCRETE PIPE	1	07/01/2001	620.00L	PAVEMENT MARKING	5	10/01/2016
604.15E	PIPE CULVERT HEADWALL - ENERGY DISSIPATOR FOR 48" CONCRETE PIPE	1	07/01/2001	620.10G	TEMPORARY PAVEMENT MARKING	5	07/01/2017
604.29C	DROP INLET - TYPE X	2	04/01/2018	625.00	HOLE PATTERN FOR PAVEMENT SLAB STABILIZATION	1	10/01/1998
604.30G	CONCRETE MANHOLES	2	02/01/2009	626.00H	RUMBLE STRIPS	2	04/01/2009
604.40F	PIPE COLLARS	2	10/01/2000				
604.70	SLOTTED DRAIN	2	03/01/1994				
605.10I	PAVEMENT UNDERDRAINAGE	4	06/01/2013				
606.00AY	GUARDRAIL	7	04/01/2018				
606.01F	MEDIAN PIER PROTECTION	9	08/01/2012				
606.22U	BRIDGE ANCHOR SECTION - SAFETY BARRIER CURB ON BRIDGE	6	07/01/2016				
606.23J	BRIDGE ANCHOR SECTION (THRIE BEAM RAIL ON BRIDGE)	5	07/01/2016				
606.30K	GUARDRAIL - TERMINAL ANCHOR ENDS	7	04/01/2017				
606.31B	CRASHWORTHY END TERMINALS - TYPE A - GRADING LIMITS *	1	10/01/2019				
606.40D	ONE-STRAND ACCESS RESTRAINT CABLE	2	07/01/2004				
606.41L	THREE-STRAND GUARD CABLE	7	04/01/2019				
606.50D	MIDWEST GUARDRAIL SYSTEM (MGS)	8	01/01/2019				
606.51	MIDWEST GUARDRAIL SYSTEM (MGS) - MEDIAN PIER PROTECTION	2	04/01/2018				

# MISSOURI HIGHWAYS AND TRANSPORTATION COMMISSION

EFFECTIVE: 10/01/2019

## MISSOURI STANDARD PLANS FOR HIGHWAY CONSTRUCTION TABLE OF CONTENTS

IF A SEAL IS PRESENT ON THIS SHEET IT HAS BEEN ELECTRONICALLY SEALED AND DATED.

STANDARD NO.	DRAWING TITLE	NO. OF SHEETS	EFFECTIVE DATE	STANDARD NO.	DRAWING TITLE	NO. OF SHEETS	EFFECTIVE DATE
703.10J	CONCRETE SINGLE BOX CULVERT - STRAIGHT WINGS (SQUARED)	3	07/01/2015	901.30F	HIGHWAY LIGHTING - BASE MOUNTED CONTROL STATION	2	04/01/2005
703.11J	CONCRETE SINGLE BOX CULVERT - FLARED WINGS (SQUARED)	3	07/01/2015	901.80D	HIGHWAY LIGHTING - POWER SUPPLY ASSEMBLY - SECONDARY SERVICE	2	04/01/2002
703.12J	CONCRETE SINGLE BOX CULVERT - STRAIGHT WINGS (LEFT ADVANCE)	3	07/01/2015	901.85B	HIGHWAY LIGHTING SYMBOLS	1	04/01/2018
703.13J	CONCRETE SINGLE BOX CULVERT - FLARED WINGS (LEFT ADVANCE)	3	07/01/2015	902.00P	TRAFFIC SIGNALS	2	04/01/2018
703.14J	CONCRETE SINGLE BOX CULVERT - STRAIGHT WINGS (RIGHT ADVANCE)	3	07/01/2015	902.10Q	TRAFFIC SIGNALS - CONTROLLERS CONDUIT LOCATION	1	04/01/2005
703.15E	CONCRETE SINGLE BOX CULVERT - FLARED WINGS (RIGHT ADVANCE)	3	07/01/2015	902.15K	TRAFFIC SIGNALS - POWER SUPPLY ASSEMBLY	3	07/01/2004
703.16	CONCRETE SINGLE BOX CULVERT - CUT SECTION	1	04/01/2011	902.20G	TRAFFIC SIGNALS - CONCRETE PULL BOXES	3	04/01/2019
703.17	CONCRETE SINGLE BOX CULVERT - MEMBER SIZES AND REINFORCEMENT	14	04/01/2011	902.21C	TRAFFIC SIGNALS - TELEPHONE INTERCONNECT	1	03/01/1996
703.37C	CONCRETE BOX CULVERT - EXTERIOR WING REINFORCEMENT	2	04/01/2011	902.30P	TRAFFIC SIGNALS - POST BASES	2	10/01/2018
703.38A	CONCRETE BOX CULVERT - CUTTING DETAILS	2	10/01/2009	902.40R	TRAFFIC SIGNALS - TUBULAR STEEL POSTS	3	04/01/2018
703.40H	CONCRETE DOUBLE BOX CULVERT - STRAIGHT WINGS (SQUARED)	3	10/01/2011	902.50L	TRAFFIC SIGNALS - INDUCTION LOOP DETECTORS	2	06/01/2009
703.41H	CONCRETE DOUBLE BOX CULVERT - FLARED WINGS (SQUARED)	3	10/01/2011	902.70P	TRAFFIC SIGNALS - RIGID SPAN WIRE DETAILS	2	04/01/2018
703.42H	CONCRETE DOUBLE BOX CULVERT - STRAIGHT WINGS (LEFT ADVANCE)	3	10/01/2011	902.80L	TRAFFIC SIGNALS - TRAFFIC SIGNAL SYMBOLS	1	07/01/2017
703.43H	CONCRETE DOUBLE BOX CULVERT - FLARED WINGS (LEFT ADVANCE)	3	10/01/2011	903.01J	STANDARD ARROW DETAILS	2	10/01/2016
703.44H	CONCRETE DOUBLE BOX CULVERT - STRAIGHT WINGS (RIGHT ADVANCE)	3	10/01/2011	903.02AP	HIGHWAY SIGNING	*	8
703.45C	CONCRETE DOUBLE BOX CULVERT - FLARED WINGS (RIGHT ADVANCE)	3	10/01/2011	903.03BM	POST INSTALLATIONS AND SIGN MOUNTING DETAILS	*	16
703.46	CONCRETE BOX CULVERT - CUT SECTION	1	10/01/2011	903.04F	HIGHWAY SIGNING - WEIGH STATION	1	02/01/2012
703.47	CONCRETE BOX CULVERT - MEMBER SIZES AND REINFORCEMENT	27	10/01/2011	903.05J	HIGHWAY SIGNING - TUBULAR SUPPORT STEEL - TYPE S, ONE TUBE	2	10/01/2016
703.60E	CONCRETE BOX STRUCTURE - PIPE INLET	1	07/01/2001	903.06J	HIGHWAY SIGNING - TUBULAR SUPPORT STEEL - TYPE S, TWO TUBE	2	10/01/2016
703.80H	CONCRETE TRIPLE BOX CULVERT - STRAIGHT WINGS (SQUARED)	3	12/01/2011	903.07J	HIGHWAY SIGNING - TUBULAR SUPPORT STEEL - TYPE C	2	10/01/2016
703.81H	CONCRETE TRIPLE BOX CULVERT - FLARED WINGS (SQUARED)	3	12/01/2011	903.08H	HIGHWAY SIGNING - TUBULAR SUPPORT STEEL - TYPE B	2	10/01/2016
703.82H	CONCRETE TRIPLE BOX CULVERT - STRAIGHT WINGS (LEFT ADVANCE)	3	12/01/2011	903.10BC	OVERHEAD SIGN TRUSSES - ALUMINUM	6	10/01/2016
703.83H	CONCRETE TRIPLE BOX CULVERT - FLARED WINGS (LEFT ADVANCE)	3	12/01/2011	903.12Z	OVERHEAD SIGN TRUSSES - BUTTERFLY AND CANTILEVER STRUCTURAL STEEL	7	10/01/2016
703.84H	CONCRETE TRIPLE BOX CULVERT - STRAIGHT WINGS (RIGHT ADVANCE)	3	12/01/2011	903.60AB	OVERHEAD SIGN TRUSSES - STRUCTURAL STEEL	5	10/01/2016
703.85C	CONCRETE TRIPLE BOX CULVERT - FLARED WINGS (RIGHT ADVANCE)	3	12/01/2011				
703.86	CONCRETE TRIPLE BOX CULVERT - CUT SECTION	1	12/01/2011				
703.87	CONCRETE TRIPLE BOX CULVERT - MEMBER SIZES AND REINFORCEMENT	27	12/01/2011				
706.35H	BAR SUPPORTS FOR CONCRETE REINFORCEMENT	1	07/01/2004				
712.40L	STEEL DAMS AT EXPANSION DEVICES	*	1				
725.00C	CORRUGATED METAL PIPE INSTALLATION METHODS	5	04/01/2011				
725.31C	METAL CURTAIN WALL AND METAL INLETS	1	07/01/2004				
726.30J	RIGID CULVERT INSTALLATION METHODS	2	04/01/2015				
730.00E	THERMOPLASTIC PIPE INSTALLATION METHODS	1	04/01/2015				
731.00U	PRECAST MANHOLES	2	07/01/2016				
731.10S	PRECAST DROP INLET	8	07/01/2016				
732.00S	FLARED END SECTION	3	04/01/2016				
732.05C	BEVELED PIPE END TREATMENT	2	07/01/2004				
732.10H	SAFETY SLOPE END SECTION	3	06/01/2013				
733.00	PRECAST CONCRETE BOX CULVERT TIES	1	04/01/2018				
806.10J	TEMPORARY EROSION CONTROL MEASURES	6	04/01/2019				
808.00	TYPICAL PLANTING ILLUSTRATIONS	3	07/01/2004				
901.00AB	HIGHWAY LIGHTING - POLES, FOUNDATIONS & APPURTENANCES FOR 30' M.H.	4	04/01/2018				
901.01AJ	HIGHWAY LIGHTING - POLES, FOUNDATIONS & APPURTENANCES FOR 45' M.H.	6	04/01/2018				
901.02B	HIGHWAY LIGHTING - CABLE, CONDUIT AND TRENCHING	1	04/01/2002				

\* REVISED OR ADDED SINCE JULY 2019

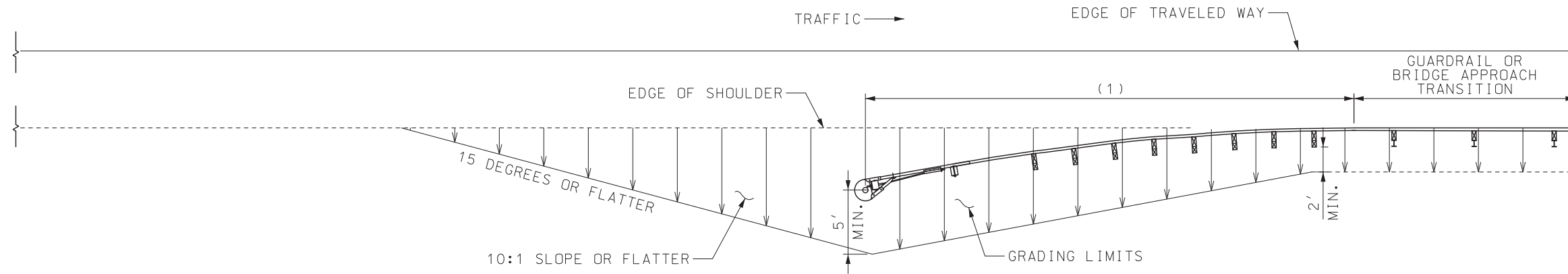

GRADING LIMITS FOR FLARED CRASHWORTHY END TERMINALS

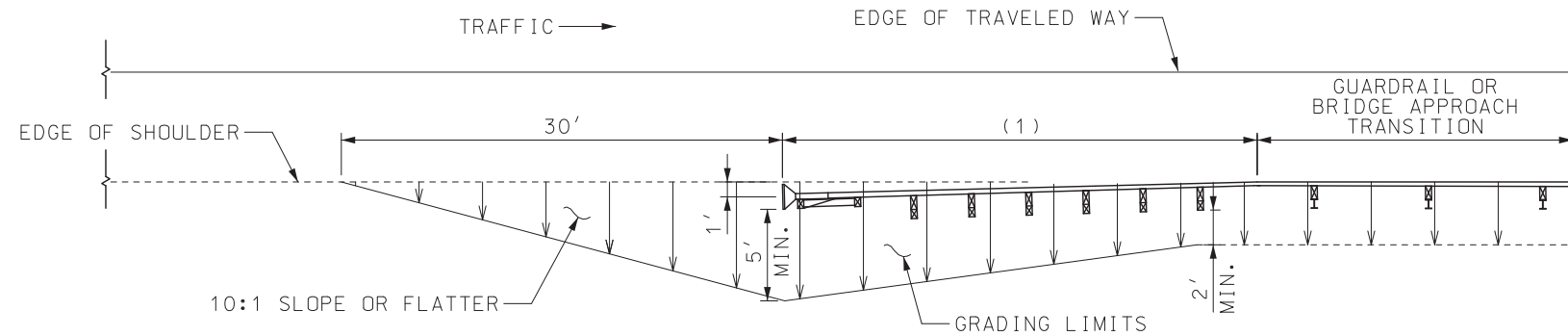

STANDARD GRADING LIMITS FOR CRASHWORTHY END TERMINALS

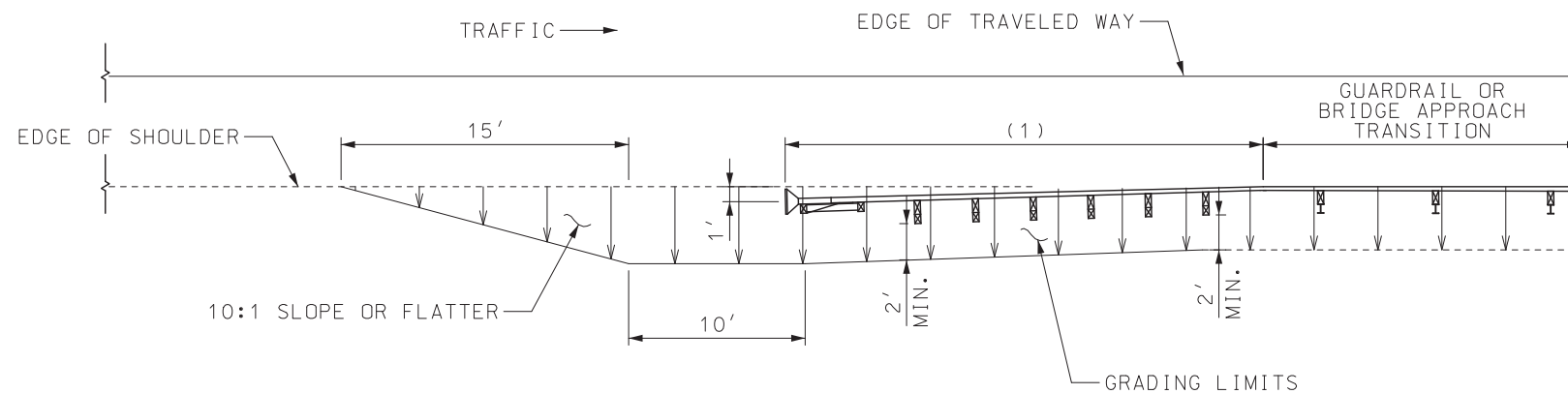

ALTERNATE GRADING LIMITS FOR CRASHWORTHY END TERMINALS

(1) APPROVED CRASHWORTHY END TERMINAL

GENERAL NOTES:

STANDARD GRADING LIMITS SHALL BE USED WHEN CONSTRUCTING A NEW ROADBED. ALTERNATE GRADING LIMITS ARE ALLOWABLE ON EXISTING ROADBEDS EXCEPT WHEN STANDARD GRADING IS INDICATED ON THE PLANS.

THE CONTRACTOR SHALL PROVIDE THE ENGINEER WITH APPROVED SHOP DRAWINGS OF THE APPROVED CRASHWORTHY END TERMINAL.

END ANCHORS SHALL BE INSTALLED ON ENDS OF GUARDRAIL RUNS WHERE CRASHWORTHY END TERMINALS ARE NOT REQUIRED.

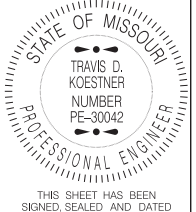
	<b>MISSOURI HIGHWAYS AND TRANSPORTATION COMMISSION</b> 105 WEST CAPITOL JEFFERSON CITY, MO 65102 1-888-ASK-MODOT (1-888-275-6636)	
		<b>CRASHWORTHY END TERMINALS TYPE A GRADING LIMITS</b>
DATE EFFECTIVE: 10/01/2019 DATE PREPARED: 7/18/2019	<b>606.31B</b>	SHEET NO. <b>1 OF 1</b>

IF A SEAL IS PRESENT ON THIS SHEET IT HAS BEEN ELECTRONICALLY SEALED AND DATED.

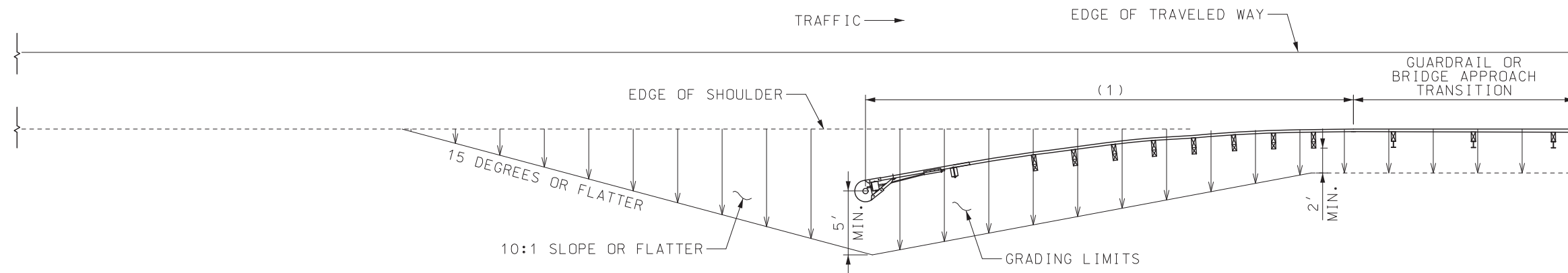

GRADING LIMITS FOR FLARED CRASHWORTHY END TERMINALS

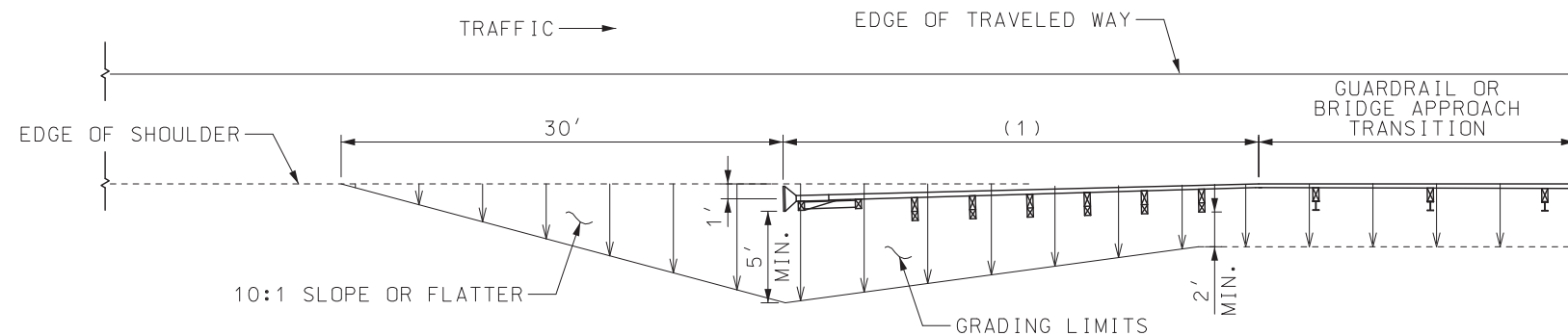

STANDARD GRADING LIMITS FOR CRASHWORTHY END TERMINALS

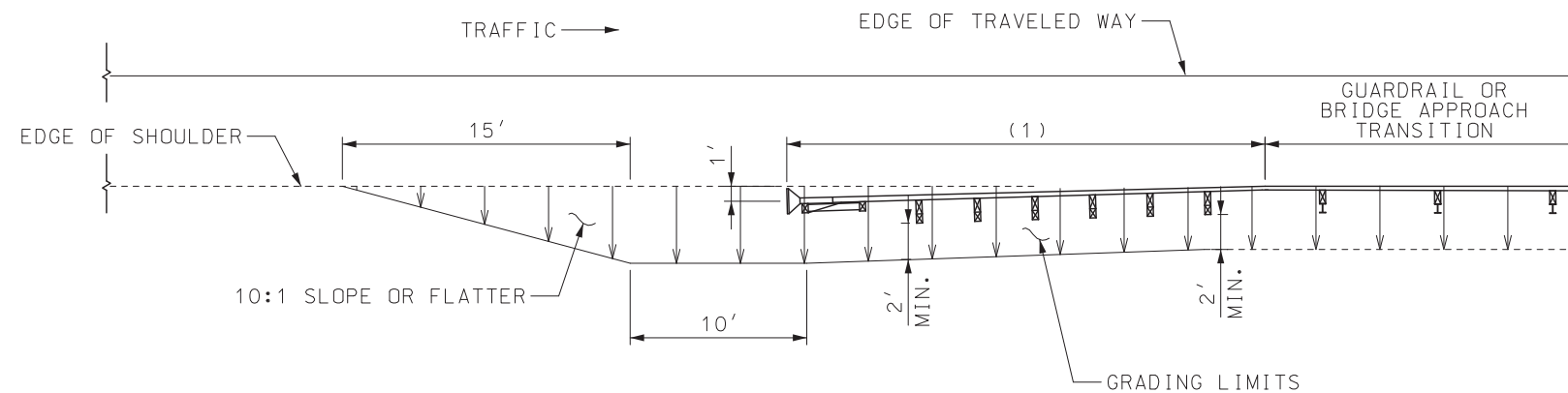

ALTERNATE GRADING LIMITS FOR CRASHWORTHY END TERMINALS

GENERAL NOTES:

STANDARD GRADING LIMITS SHALL BE USED WHEN CONSTRUCTING A NEW ROADBED. ALTERNATE GRADING LIMITS ARE ALLOWABLE ON EXISTING ROADBEDS EXCEPT WHEN STANDARD GRADING IS INDICATED ON THE PLANS.

THE CONTRACTOR SHALL PROVIDE THE ENGINEER WITH APPROVED SHOP DRAWINGS OF THE MASH APPROVED CRASHWORTHY END TERMINAL.

END ANCHORS SHALL BE INSTALLED ON ENDS OF GUARDRAIL RUNS WHERE CRASHWORTHY END TERMINALS ARE NOT REQUIRED.

(1) APPROVED CRASHWORTHY END TERMINAL

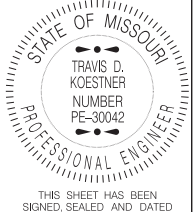
	<b>MISSOURI HIGHWAYS AND TRANSPORTATION COMMISSION</b> 105 WEST CAPITOL JEFFERSON CITY, MO 65102 1-888-ASK-MODOT (1-888-275-6636)	
		<b>MASH CRASHWORTHY END TERMINALS TYPE A GRADING LIMITS</b>
DATE EFFECTIVE: 10/01/2019 DATE PREPARED: 7/18/2019	<b>606.81B</b>	SHEET NO. <b>1 OF 1</b>

IF A SEAL IS PRESENT ON THIS SHEET IT HAS BEEN ELECTRONICALLY SEALED AND DATED.

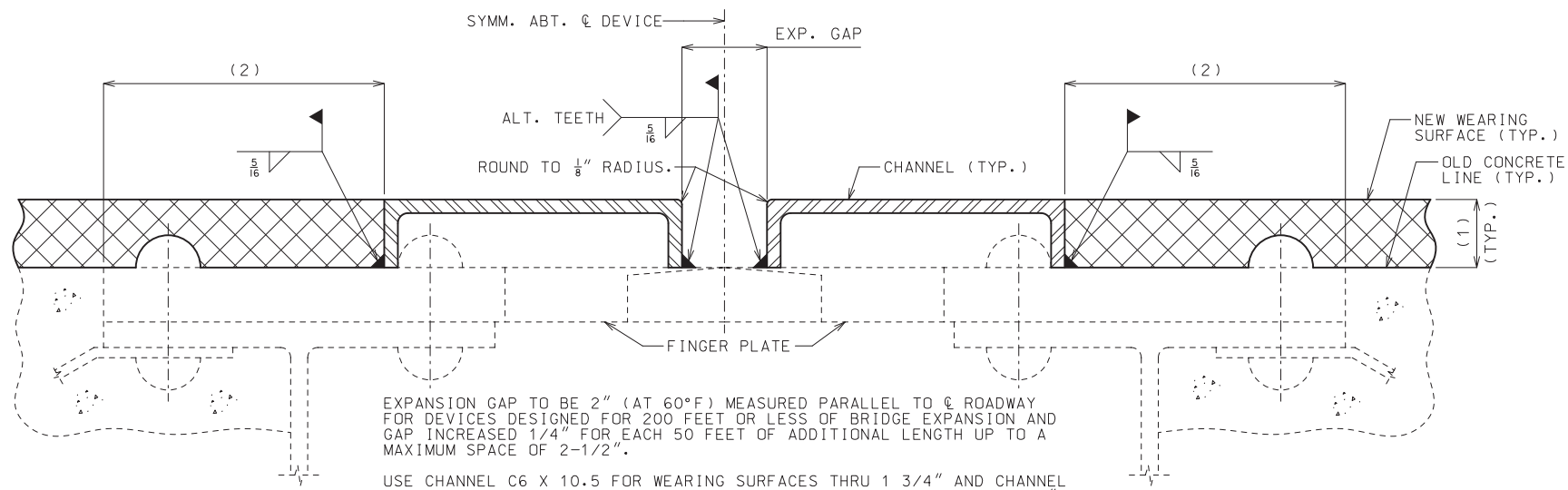

EXPANSION GAP TO BE 2" (AT 60°F) MEASURED PARALLEL TO C ROADWAY FOR DEVICES DESIGNED FOR 200 FEET OR LESS OF BRIDGE EXPANSION AND GAP INCREASED 1/4" FOR EACH 50 FEET OF ADDITIONAL LENGTH UP TO A MAXIMUM SPACE OF 2-1/2".

USE CHANNEL C6 X 10.5 FOR WEARING SURFACES THRU 1 3/4" AND CHANNEL C7 X 14.75 OR MC6 X 15.1 FOR WEARING SURFACES GREATER THAN 1 3/4" TO 2 1/4". CUT FLANGES TO MATCH REQUIRED WEARING SURFACE THICKNESS AND NOTCH FLANGE WHERE NECESSARY TO CLEAR RIVET HEADS.

PART SECTION THRU EXPANSION DEVICE

TYPE A - FINGER TYPE EXPANSION DEVICES

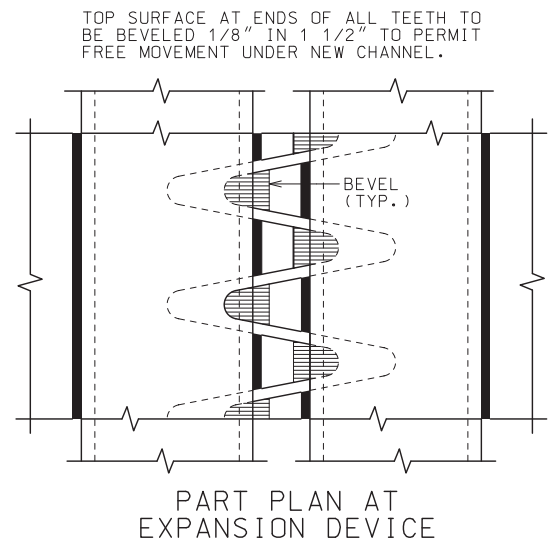

PART PLAN AT EXPANSION DEVICE

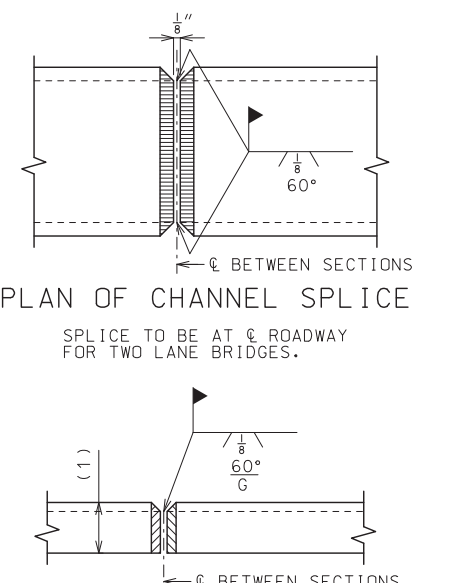

PLAN OF CHANNEL SPLICE  
ELEVATION OF CHANNEL SPLICE

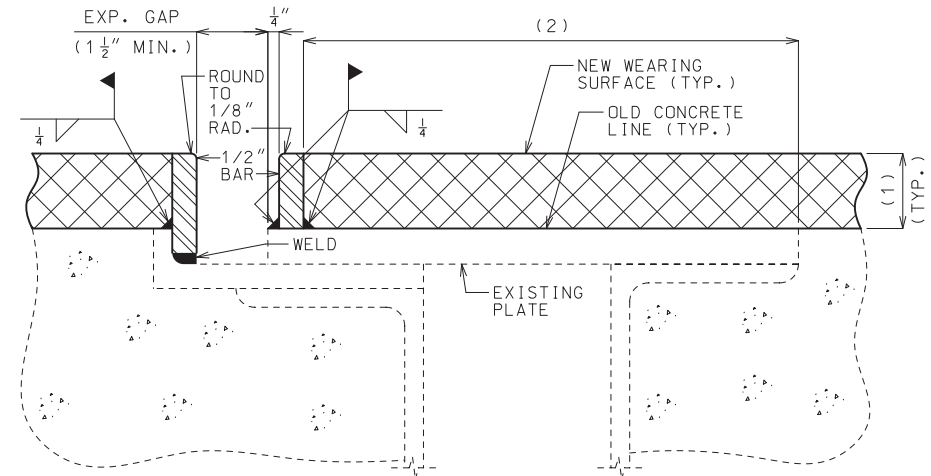

PART SECTION AT EXPANSION DEVICE

TYPE B - PLATE TYPE EXPANSION DEVICES

- (1) WEARING SURFACE THICKNESS
- (2) WHEN THIS DIMENSION EXCEEDS 3" AND A CONCRETE WEARING SURFACE IS USED, TACK WELD A ONE INCH BAR CHAIR TO THE PLATE OR ANGLE FOR EACH 3" OF PLATE OR ANGLE TO BE COVERED BY WEARING SURFACE.

GENERAL NOTES:

- OUTLINE OF OLD WORK IS INDICATED BY LIGHT DASHED LINES. HEAVY LINES INDICATE NEW WORK.
- THE EXISTING EXPANSION DEVICE PLATES SHALL BE CHECKED FOR LOOSENESS AND SECURED BEFORE THE NEW BAR DAM IS INSTALLED.
- STRUCTURAL STEEL SHALL BE IN ACCORDANCE WITH ASTM A70 GRADE 36.
- QUALIFICATION OF WELDING OPERATORS WILL BE REQUIRED.
- E7016 OR E7018 ELECTRODES SHALL BE USED.
- THE STEEL DAMS SHALL EXTEND FULL ROADWAY WIDTH BETWEEN CURBS, BUT SHALL BE INSTALLED IN SECTIONS OF SUCH LENGTHS TO PERMIT AT LEAST ONE WAY TRAFFIC AT ALL TIMES. BEFORE TRAFFIC IS PERMITTED TO CROSS OVER SECTIONS OF DAMS IN PLACE, SUFFICIENT WEARING SURFACE SHALL BE PLACED ON ROADWAY SLAB ADJACENT TO BOTH SIDES OF EXPANSION DEVICE TO PREVENT ANY DAMAGE TO EITHER THE STEEL DAMS OR TIRES OF VEHICLES.
- STEEL DAMS SHALL BE FABRICATED AND INSTALLED TO THE CROWN AND GRADE OF THE ROADWAY.
- STEEL CHANNELS OR BARS ON BOTH SIDES OF EXPANSION JOINT, FOR FULL WIDTH OF ROADWAY, WILL BE CONSIDERED COMPLETELY COVERED BY THE CONTRACT UNIT PRICE FOR STEEL BAR DAM.
- PAINT INSIDE SURFACE OF CHANNEL 5.0 MILS THICKNESS OF INORGANIC ZINC PRIMER.
- SHOP DRAWINGS WILL NOT BE REQUIRED FOR STEEL BAR DAMS.

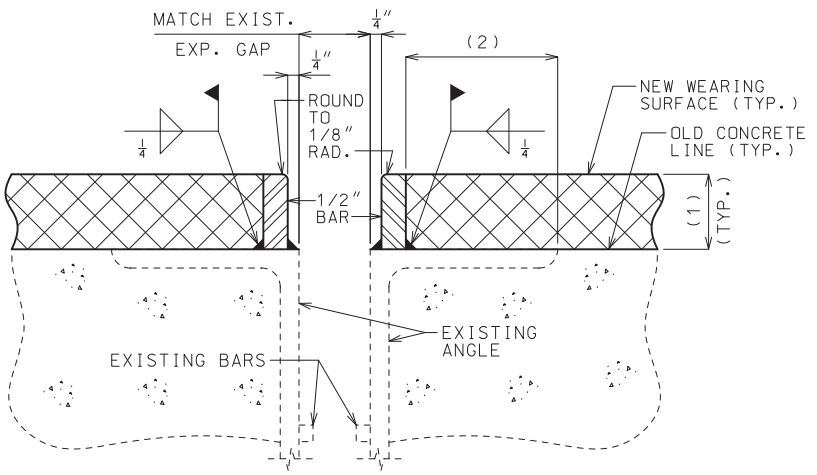

PART SECTION AT EXPANSION DEVICE

TYPE C - ANGLE TYPE EXPANSION DEVICES

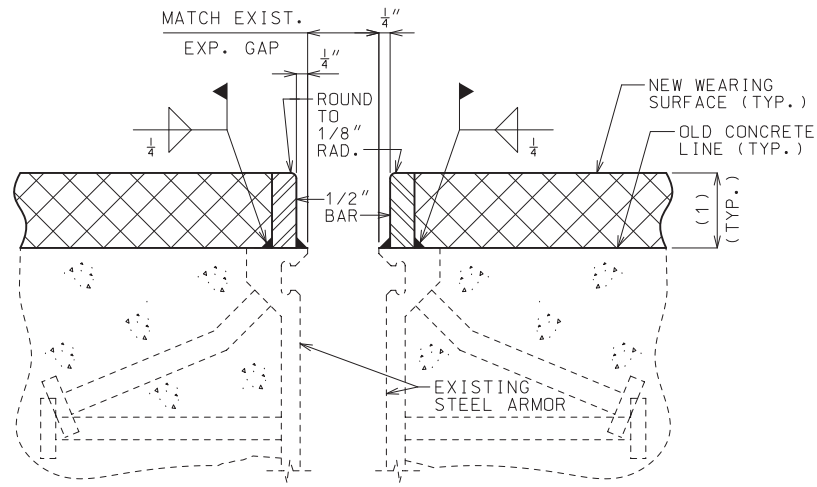

PART SECTION AT EXPANSION DEVICE

TYPE D - STRIP SEAL TYPE EXPANSION DEVICES

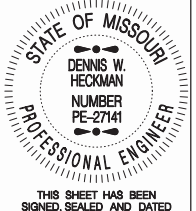
 <b>MISSOURI HIGHWAYS AND TRANSPORTATION COMMISSION</b> 105 WEST CAPITOL JEFFERSON CITY, MO 65102 1-888-ASK-MODOT (1-888-275-6636)	
	<p align="center"><b>STEEL DAMS</b></p> <p align="center">AT EXPANSION DEVICES FOR RESURFACING BRIDGE FLOORS</p>
DATE EFFECTIVE: 10/01/2019 DATE PREPARED: 7/18/2019	<p align="center"><b>712.40L</b></p>
SHEET NO. <p align="center">1 OF 1</p>	

IF A SEAL IS PRESENT ON THIS SHEET IT HAS BEEN ELECTRONICALLY SEALED AND DATED.

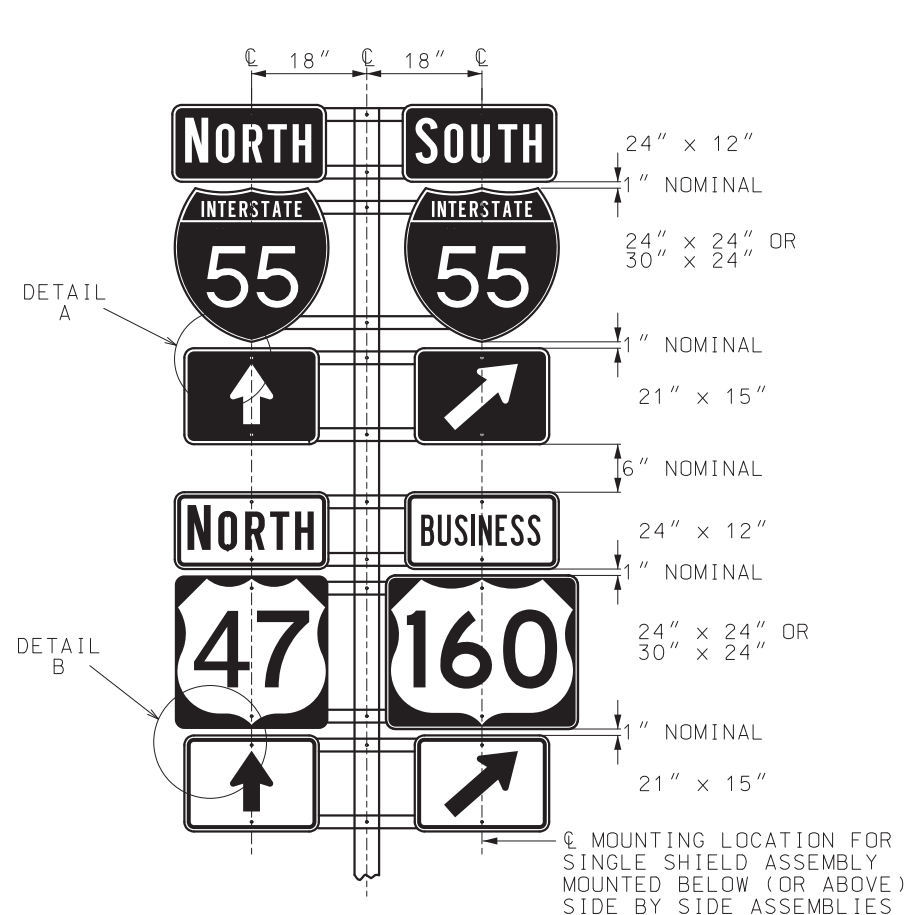

**ONE POST ASSEMBLY**  
USE TO SUPPORT UP TO 4 ROUTE MARKERS

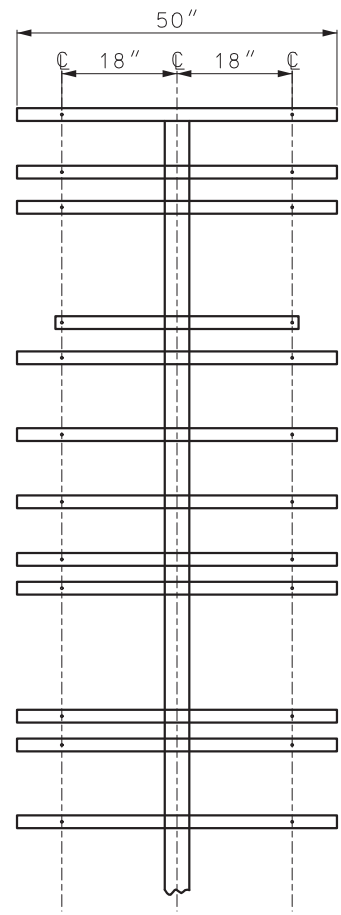

**STANDARD BACKING BAR LAYOUT**

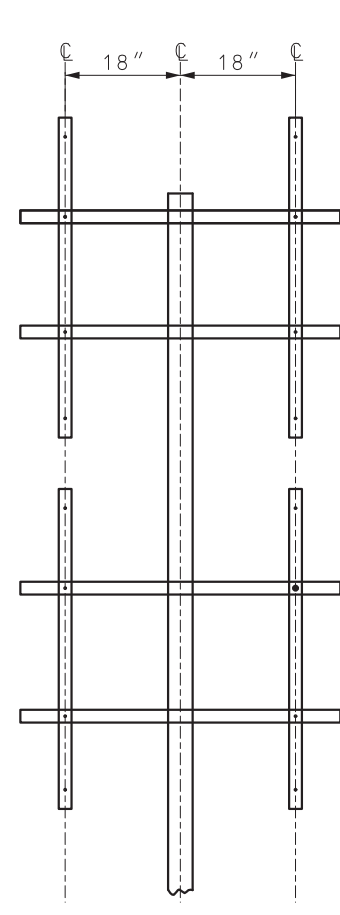

**OPTIONAL BACKING BAR LAYOUT**

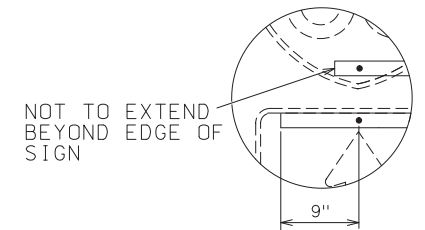

**DETAIL A**  
SEE GENERAL NOTES

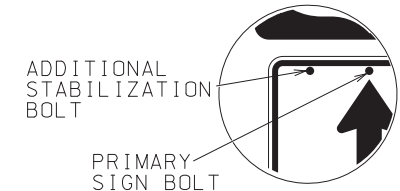

**DETAIL B**  
SEE GENERAL NOTES

**GENERAL NOTES:**

ALL BACKING BARS SHALL BE 2" x 3/8" STEEL, GALVANIZED AFTER PUNCHING. WEIGHT = 2.55 LBS. PER FOOT. HOLES IN BARS SHALL BE 3/8" AND SHALL BE PUNCHED AS SHOWN ON THIS DRAWING.

DETAIL A - THE END OF THE HORIZONTAL BACKING BARS SHALL EXTEND MAXIMUM OF 9 INCHES PAST THE SIGN BOLT, BUT SHALL NOT EXTEND PAST THE EDGE OF THE SIGN.

DETAIL B - FOR SIGNS INSTALLED ON TWO PARALLEL HORIZONTAL BACKING BARS, ONE ADDITIONAL BOLT SHALL BE ADDED TO THE LEFT SIGN TO KEEP ASSEMBLY SQUARE.

WHEN USING OPTIONAL BACKING BAR LAYOUT, VERTICAL BARS SHALL BE MOUNTED BEHIND HORIZONTAL BARS.

BACKING BARS SHALL MEET MISSOURI STANDARD PLANS OR APPROVED PRODUCTS LIST.

BACKING BARS PAID FOR AS STRUCTURAL STEEL, PER POUND.

ALL SIGNS TO BE INSTALLED ALONG VERTICAL CENTERLINES.

FOR POST AND FOOTING DATA AND DETAILS OF SHIELDS AND PLAQUES, SEE OTHER DRAWINGS.

NOMINAL VERTICAL SPACING INDICATED BETWEEN SIGNS TO BE ACHIEVED BY USING THE CLOSEST AVAILABLE HOLES WHEN USING PSST.

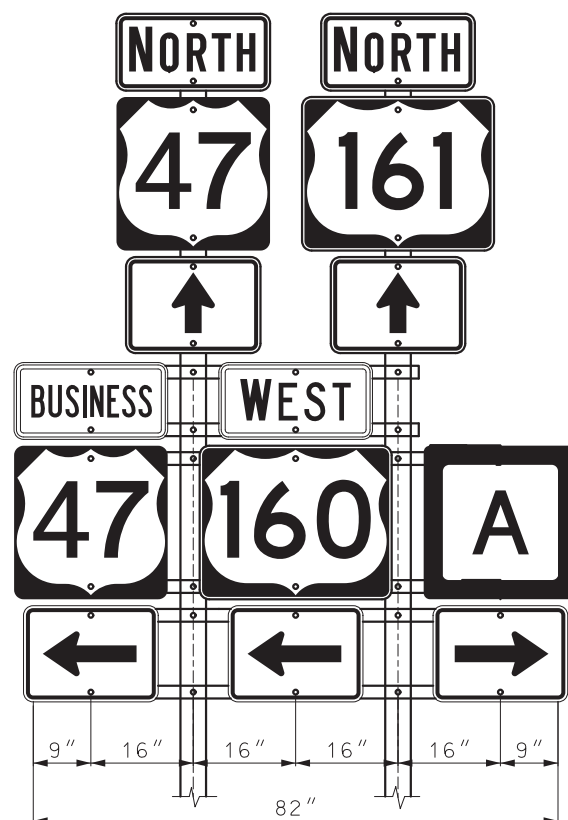

**TWO POST ASSEMBLY**  
USE TO SUPPORT 5 OR 6 ROUTE MARKERS

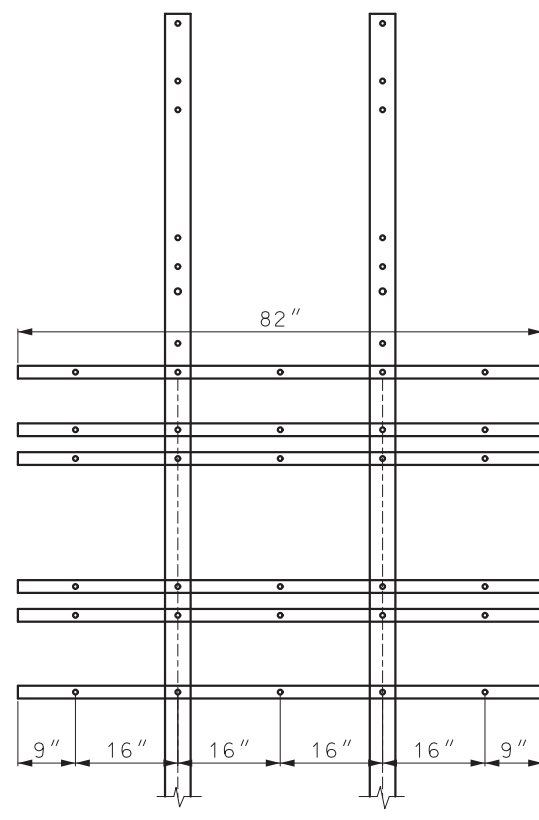

**STANDARD BACKING BAR LAYOUT**

**TWO POST ASSEMBLY NOTE:**

OPTIONAL BACKING BAR LAYOUT MAY BE USED WITH TWO POST ASSEMBLY.

FOR 6 ROUTE SHIELD ASSEMBLY ADDITIONAL BACKING BARS ARE REQUIRED.

**POST SELECTION**

SINGLE POST ASSEMBLIES SHALL USE A 4" PIPE POST OR A 2 1/2" PSST POST.

TWO POST ASSEMBLIES SHALL USE TWO 4" PIPE POSTS OR TWO 2 1/2" PSST POST WITH 2 1/4" PSST INSERTS AND BREAKAWAYS. (SEE STANDARD PLAN 903.03)

**MoDOT** MISSOURI HIGHWAYS AND TRANSPORTATION COMMISSION  
105 WEST CAPITOL  
JEFFERSON CITY, MO 65102  
1-888-ASK-MODOT (1-888-275-6636)

STATE OF MISSOURI  
NICOLE A. KOLB HOOD  
NUMBER PE-2001018764  
PROFESSIONAL ENGINEER  
THIS SHEET HAS BEEN SIGNED, SEALED AND DATED ELECTRONICALLY.

**HIGHWAY SIGNING  
BACKING BARS  
SHEET SIGN MOUNTING  
ROUTE SHIELD AND  
MARKER ASSEMBLIES**

DATE EFFECTIVE: 10/01/2019	<b>903.02AP</b>	SHEET NO. 4 OF 8
DATE PREPARED: 7/18/2019		

IF A SEAL IS PRESENT ON THIS SHEET IT HAS BEEN ELECTRONICALLY SEALED AND DATED.

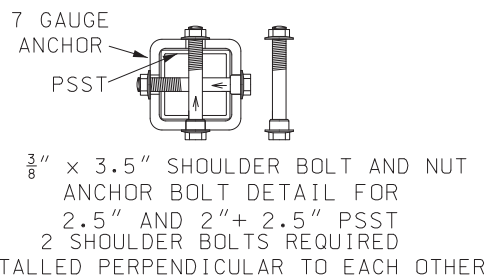
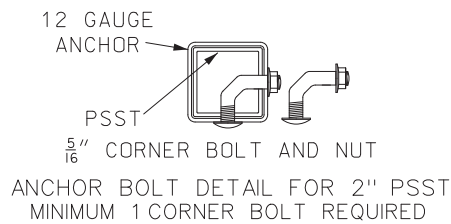

**ANCHOR BOLT DETAIL**

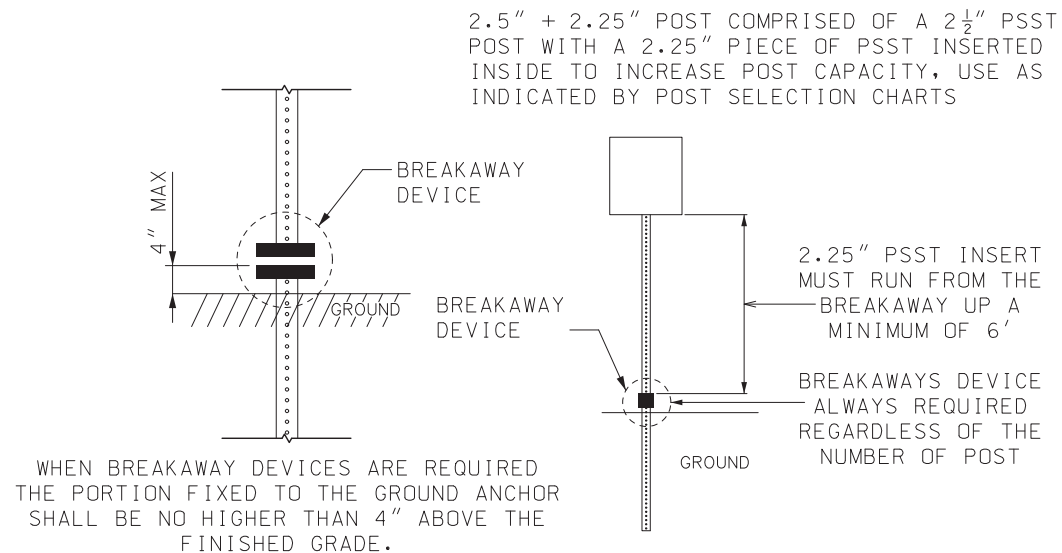

**BREAKAWAY DETAILS  
2.5" + 2.25" POST DETAIL**

ANCHOR TUBE SHALL BE 7 GAUGE

1/2" X 4 1/2" GALVANIZED MECHANICAL FASTENERS SHALL BE USED TO ATTACH ANCHOR TO BARRIER WALL

SHOULDER BOLTS SHALL BE USED TO ATTACH PSST POST TO ANCHOR (SEE STANDARD PLAN 903.03)

ANCHOR SHALL BE HOT DIPPED GALVANIZED AFTER FABRICATION PER SECTION 1080

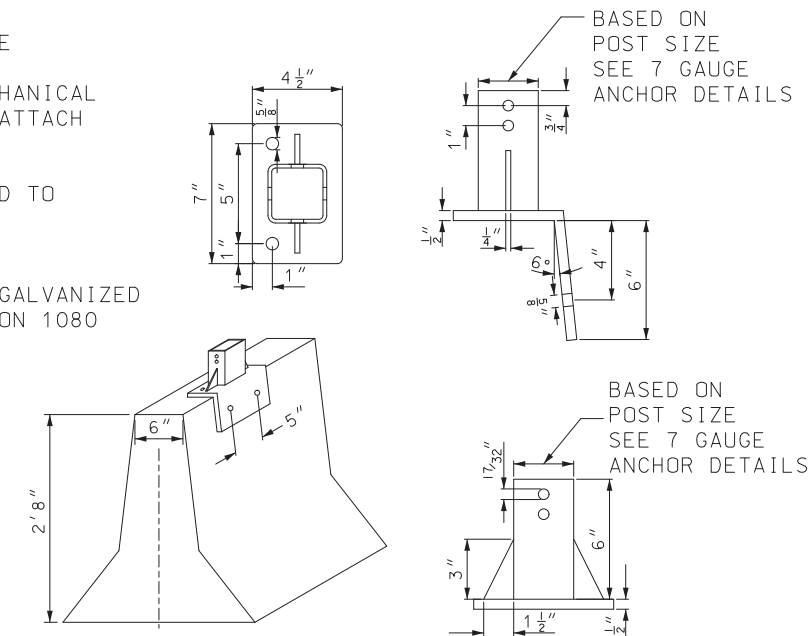

**BARRIER WALL MOUNTING DETAIL**

THE ANCHOR SHOULD BE A MAXIMUM OF 2.5" ABOVE THE GROUND LEVEL

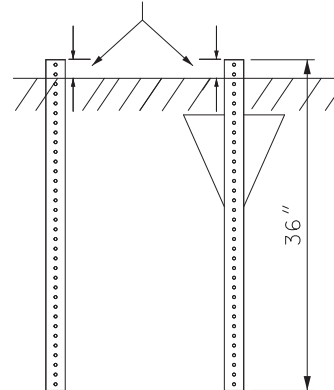

12 GAUGE

**ANCHOR INSTALLATION DETAIL**

THE ANCHOR SHOULD BE A MAXIMUM OF 2.5" ABOVE THE GROUND LEVEL

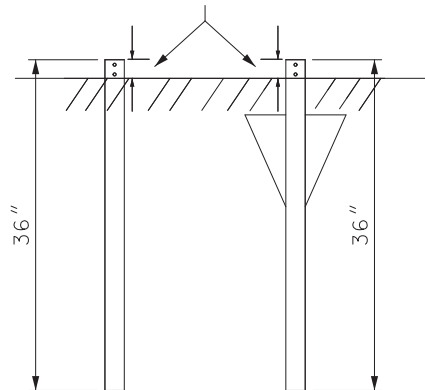

7 GAUGE

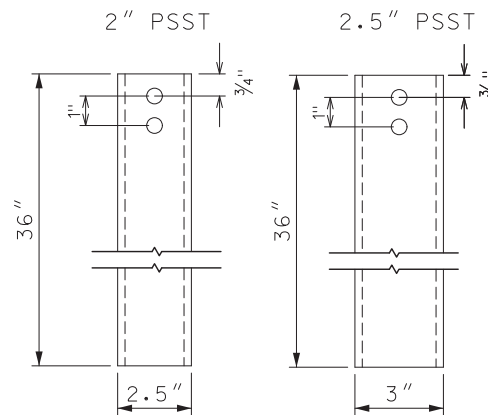

- BOLT HOLE DIAMETER - 17/32"

- 2 PER SIGN ON ALL 4 SIDES

**7 GAUGE ANCHOR FABRICATION DETAIL**

POST AND ANCHOR DATA TABLE						
POST		ANCHOR		BREAKAWAY NEEDED		
GAUGE	SIZE	GAUGE	SIZE	NUMBER OF POSTS		
				1	2	3
12	2"x2"	12	2.25" X 2.25" X 36" OD	NO	NO	YES
		7 *	2.5" X 2.5" X 36" OD	NO	NO	YES
12	2.5"x2.5"	7 *	3" X 3" X 36" OD	NO	YES	YES
12	(2.5"x2.5")+(2.25"x2.25")	7 *	3" X 3" X 36" OD	YES	YES	YES

\* TO BE USED WITH CONCRETE FOOTINGS OR IS AN OPTION IN ROCK SOIL CONDITIONS

NOTES:

FOR GENERAL NOTES, SEE SHEET 1 OF 16.

FOR MOUNTING HEIGHT AND OFFSET DETAILS, SEE SHEET 10 OF 16.

ALL BREAKAWAY DEVICES USED ON AN INSTALLATION SHALL BE CERTIFIED NCHRP 350 COMPLIANT.

48" FOOTINGS MAY BE USED WITH 12 GAUGE OR 7 GAUGE ANCHORS.

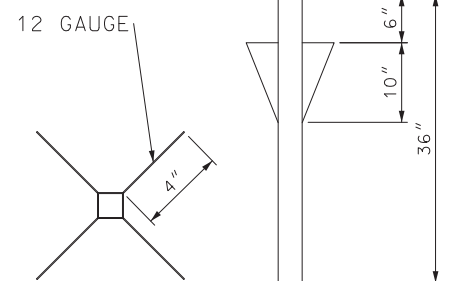

**OMNI-DIRECTIONAL ANCHOR DETAIL FOR BOTH 12 AND 7 GAUGE**

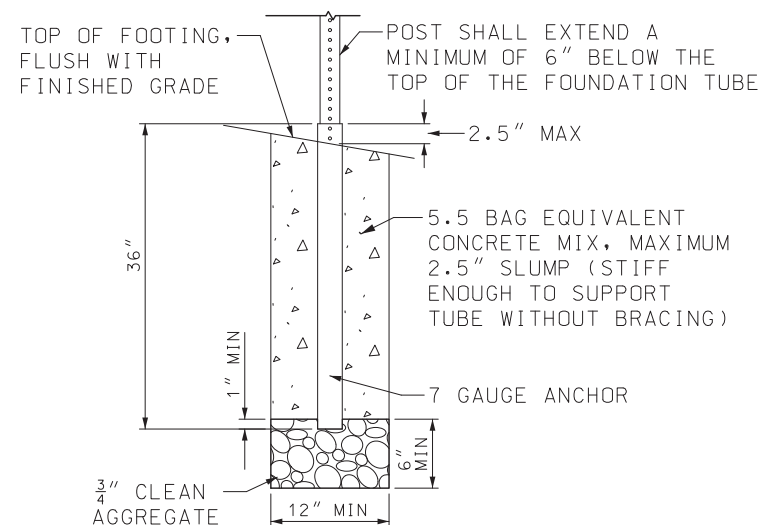

**CONCRETE FOOTING DETAIL**

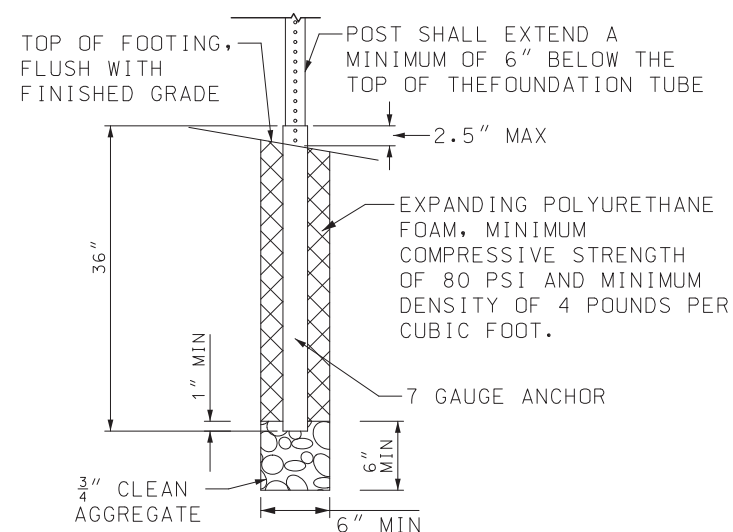

**EXPANDING FOAM FOOTING DETAIL**

**MoDOT** MISSOURI HIGHWAYS AND TRANSPORTATION COMMISSION

105 WEST CAPITOL  
JEFFERSON CITY, MO 65102  
1-888-ASK-MODOT (1-888-275-6636)

STATE OF MISSOURI  
NICOLE A. KOLB HOOD  
NUMBER PE-2001018754  
PROFESSIONAL ENGINEER

THIS SHEET HAS BEEN SIGNED SEALED AND DATED ELECTRONICALLY.

**POST INSTALLATION DETAILS**  
**PERFORATED SQUARE STEEL TUBE (PSST)**

DATE EFFECTIVE: 10/01/2019  
DATE PREPARED: 7/18/2019

903.03BM

SHEET NO.  
7 OF 16

IF A SEAL IS PRESENT ON THIS SHEET IT HAS BEEN ELECTRONICALLY SEALED AND DATED.

REV.