

WCI24000071

Jefferson County Port Authority
114 Mississippi Ave,
Crystal City, MO 63019

REQUEST FOR BID

BID OF

Bidder Name _____

Bidder Address _____

FOR
CONSTRUCTING RIVERVIEW PLAZA DRIVE
Reconstruction of Existing Roadway along Riverview Plaza Drive to connect to Port Entrance
Road.

Riverview Plaza Drive
Herculaneum, MO (Jefferson County)

INVITATION FOR BIDS

Sealed bids for the Jefferson County Port Authority, Missouri (hereinafter “Owner”) Roadway Improvements, WCI24000071 (hereinafter “Project”) will be received by the Jefferson County Port Authority, 114 Mississippi Ave, Crystal City, MO 63019 until 3:00 p.m. local time, on December 9th 2024, at which time the bids will be publicly opened and read aloud.

The Scope of Work includes grading, removal of improvements, concrete pavement, guardrail, concrete curb ramp installation, and traffic control within the Jefferson County Port Authority Site and other incidental items and work described in the Project Manual, or reasonably inferable therefrom. The Jefferson County Port Authority anticipates issuing notice to proceed in February of 2025.

Bid Packages will be distributed electronically via an ftp link at no cost to the bidder. Hard copies will not be available for purchase. Bidders may make printed copies of the bid documents (plans, project manual, and bid packet) at their own expense. When requesting the ftp link, you will be required to provide your company name, a contact person and phone number, a complete company address and an e-mail address to be added to the Plan Holders List and for receiving official bidding communications and addenda. If you are not on the Plan Holders List, you will not receive any addenda issued. To request the electronic ftp link, email Alonzo Washington at Alonzo.washington@wsp.com. Project and bidding questions shall be exclusively via e-mail. Any questions regarding the project must be submitted by 3:00 p.m. local time on December 9th 2024. No written questions after this date or any verbal questions will be recognized.



A bid security in the amount of five percent (5%) of the bid amount must accompany each bid, in accordance with the Instructions to Bidders.

For a contractor to be awarded this project the contractor must have a fully responsive contractor questionnaire on file with the Jefferson County Port Authority at least 7 days prior to the bid opening date. All bidders must be on MODOT’s Qualified Contractor List per Section 102.2 of the current Missouri Standard Specification for Highway Construction. No Second Tier Subcontracting will be allowed.

The wage rates applicable to this project have been predetermined as required by law and are set forth in this specification. When Federal wage rates are applicable and included, this contract is subject to the “Work Hours Act of 1962”, (P.L. 87-581: 76 Stat. 357) and implementing regulations. When state and federal wage rates are both required the higher of the tw for each job classification shall be used.

Effective January 1, 2009 and pursuant to RSMo 285.530 (1), No business entity or employer shall knowingly employ, hire for employment, or continue to employ unauthorized alien to perform work within the state of Missouri. The successful bidder must submit a sworn affidavit and documentation

affirming the business entity's enrollment and participation in the federal work authorization program and that all of its employees working for the contracted services are not illegal immigrants.

Upon signing the contract, the successful contractor and any subcontractor performing the work shall provide a ten hour Occupational Safety and Health Administration (OSHA) construction safety program for their on-site employees within sixty (60) days of beginning work on the construction project.

The Jefferson County Port Authority, Missouri hereby notifies all bidders that it will affirmatively ensure that in any contract entered into pursuant to this advertisement, business owned and controlled by socially and economically disadvantaged individuals will be afforded full opportunity to submit bids in response to this invitation and will not be discriminated against on the grounds of race, color, religion, creed, sex, age, ancestry, or national origin in consideration for an award.

The DBE Contract Goal for this project is 14.7%, and DBE firms must be certified by MoDOT to attain credit towards this contract goal. The On the Job Trainee goal is 1 OJT.

THE OWNER INTENDS TO AWARD THE CONTRACT TO THE LOWEST, RESPONSIVE, RESPONSIBLE BIDDER. THE OWNER RESERVES THE RIGHT TO REJECT ANY AND ALL BIDS, AND TO WAIVE ANY IRREGULARITIES IN THE BEST INTEREST OF THE OWNER WITH MODOT'S CONSENT.

TABLE OF CONTENTS

Notice to Contractors

Proposed Work (1)
Compliance With Contract Provisions (2)
Period of Performance..... (3)
Liquidated Damages..... (4)
Bid Guaranty (5)
Certifications for Federal Jobs (6)
Antidiscrimination (7)
Federal and State Inspection..... (8)
Prevailing Wage..... (9)
Worker Eligibility Requirements (10)
OSHA Training Requirements..... (11)
Buy America Requirements..... (12)
Addendum Acknowledgement..... (13)
Signature and Identity of Bidder (14)
Trainees (15)
Subcontractor Disclosure..... (16)
Project Award..... (17)
Materials Inspections..... (18)
Prime Contractor Requirements..... (19)
Tax Exempt Status (20)
Instructions for Bidders.....(21)

Itemized Bid Sheets

Bid Bond

Subcontractor Certification regarding Affirmative Action

Subcontractor Approval Form

DBE Identification Submittal ([Fig. 136.9.9](#))

DBE Provisions ([Fig. 136.9.8](#))

General Provisions Owner-Contractor Agreement

Job Special Provisions ([Sample JSP's](#) on MoDOT's Website)

Federal Aid Provisions

Applicable State Wage Rates

ADA Checklist ([Fig. 136.9.4](#))

NOTICE TO CONTRACTORS

Sealed bids, addressed to the Jefferson County Port Authority for the proposed work will be received by the Jefferson County Port Authority until 3:00 p.m. (prevailing local time) on December 9th, 2024, at the office of the Jefferson County Port Authority, and at that time will be publicly opened. Bids should be delivered to: 114 Mississippi Ave, Crystal City, MO 63019

(1) **PROPOSED WORK:** The proposed work, hereinafter called the work, includes:

grading, removal of improvements, concrete pavement, guardrail, concrete curb ramp installation, and traffic control within the Jefferson County Port Authority Site and other incidental items and work described in the Project Manual, or reasonably inferable therefrom.

(2) **COMPLIANCE WITH CONTRACT PROVISIONS:** The bidder, having examined and being familiar with the local conditions affecting the work, and with the contract, contract documents, including the current version of the Missouri Highways and Transportation Commission's "Missouri Standard Specifications for Highway Construction," and "Missouri Standard Plans for Highway Construction" (if applicable), their revisions, and the request for bid, including appendices, the special provisions and plans, hereby proposes to furnish all labor, materials, equipment, services, etc., required for the performance and completion of the work. All references are to the Missouri Standard Specifications for Highway Construction, as revised, unless otherwise noted.

The Contract Documents, except for Modifications issued after the execution of this Agreement, are enumerated as follows:

- Owner-Contractor Agreement
- General Conditions of the Owner-Contractor Agreement
- Job Special Provision
- Drawings: Jefferson County Port Authority, WCI24000071
- Performance and Payment Bond
- State Wage Determination
- Subcontractor Approval Form

The following documents are available on the Missouri Department of Transportation web page at www.modot.mo.gov under "Business with MoDOT" "Standards and Specifications". The effective version shall be determined by the letting date of the project.

General Provisions & Supplemental Specifications

Supplemental Revisions to Missouri Standard Plans
For Highway Construction (if applicable)

These supplemental bidding documents contain all current revisions to the bound printed versions and have important legal consequences. It shall be conclusively presumed that they are in the bidder's possession, and they have been reviewed and used by the bidder in the preparation of any bid submitted on this project.

Please note that within the above-listed documents, the term "Commission" shall be replaced with the term, Jefferson County Port Authority, Missouri", and the term "Engineer" is a reference to the Engineer of Record from WSP USA Inc, 211 North Broadway Suite 2800, St. Louis MO 63102.

The contracting authority for this contract is The Jefferson County Port Authority, Missouri.

(3) **PERIOD OF PERFORMANCE:** If the bid is accepted, the bidder agrees that work shall be diligently

prosecuted at such rate and in such manner as, in the judgment of the engineer, is necessary for the completion of the work within the time specified as follows in accordance with Sec 108:

Calendar Days: 365

(4) **LIQUIDATED DAMAGES:** The bidder agrees that, should the bidder fail to complete the work in the time specified or such additional time as may be allowed by the engineer under the contract, the amount of liquidated damages to be recovered in accordance with Sec 108 shall be as follows:

Liquidated damages per day \$ 1.350.00

(5) **BID GUARANTY:** The bidder shall submit a Bid Guaranty meeting the requirements of Section 102 of the Missouri Standard Specifications for Highway Construction (if applicable). A sample project bid bond form is included in the bid book. The bidder shall mark the box below to identify the type of Bid Guaranty.

- Paper Bid Bond
- Cashier's Check

(6) **CERTIFICATIONS FOR FEDERAL JOBS:** By signing and submitting this bid, the bidder makes the certifications appearing in Sec. 102.18.1 (regarding affirmative action and equal opportunity), Sec. 102.18.2 (regarding disbarment, eligibility, indictments, convictions, or civil judgments), Sec. 102.18.3 (regarding anti-collusion), and Sec. 102.18.4 (regarding lobbying activities). Any necessary documentation is to accompany the bid submission, as required by these sections. As provided in Sec. 108.13, the contracting authority may terminate the contract for acts of misconduct, which includes but is not limited to fraud, dishonesty, and material misrepresentation or omission of fact within the bid submission.

(7) **ANTIDISCRIMINATION:** The Contracting Authority hereby notifies all bidders that it will affirmatively insure that in any contract entered into pursuant to this advertisement, businesses owned and controlled by socially and economically disadvantaged individuals will be afforded full opportunity to submit bids in response to this invitation and will not be discriminated against on the grounds of race, color, religion, creed, sex, age, ancestry, or national origin in consideration for an award.

(8) **FEDERAL AND STATE INSPECTION:** The Federal Government is participating in the cost of construction of this project. All applicable Federal laws, and the regulations made pursuant to such laws, shall be observed by the contractor, and the work will be subject to the inspection of the appropriate State or Federal Agency in the same manner as provided in Sec 105.10 of the Missouri Standard Specifications for Highway Construction with all revisions applicable to this bid and contract.

(9) **PREVAILING WAGE (FEDERAL AND STATE):** This contract requires payment of the prevailing hourly rate of wages for each craft or type of work required to execute the contract as determined by the Missouri Department of Labor and Industrial Relations, and requires adherence to a schedule of minimum wages as determined by the United States Department of Labor. For work performed anywhere on this project, the contractor and the contractor's subcontractors shall pay the higher of these two applicable wage rates. The applicable state wage rates for this contract are detailed in "Annual Wage Order No. 31", that is attached to this bidding document. The applicable federal wage rates for this contract are the effective Davis-Bacon federal wage rates posted the tenth day before the bid opening date and are attached herein.

These supplemental bidding documents have important legal consequences. It shall be conclusively presumed that they are in the bidder's possession, and they have been reviewed and used by the bidder in the preparation of any bid submitted on this project.

(10) **WORKER ELIGIBILITY REQUIREMENTS:** Execution of the construction contract for this project is dependent upon the awarded bidder providing an Affidavit of Compliance AND E-Verify Memorandum-of-Understanding (MOU) between the bidder and Department of Homeland Security to the Contracting Authority as required by section 285.530 RSMo. The cover page and signature page of the E-Verify MOU and the Affidavit must be submitted prior to award of this contract.

A sample Affidavit of Compliance can be found at the Missouri Attorney General's website at the following link:

http://ago.mo.gov/forms/Affidavit_of_Compliance.pdf

All bidders must also be enrolled in the E-Verify Program, and include their MOU prior to contract execution. Bidders who are not enrolled will need to go to the following website link and select "Enroll in the Program" to get started. After completing the program, they will receive their E-Verify MOU with Department of Homeland Security. This document will need to be printed out and kept on file so that a copy can be attached to the Affidavit of Compliance.

http://www.dhs.gov/files/programs/gc_1185221678150.shtm

This requirement also applies to subcontractors and contract labor, but this contract only requires submittal of the verification documents for the prime contractor. It is the prime contractor's responsibility to verify the worker eligibility of their subcontractors in order to protect their own company from liability as required by section 285.530 RSMo.

(11) **OSHA TEN HOUR TRAINING REQUIREMENTS:** Missouri Law, 292.675 RSMO, requires any awarded contractor and its subcontractor(s) to provide a ten-hour Occupational Safety and Health Administration (OSHA) Construction Safety Program (or a similar program approved by the Missouri Department of Labor and Industrial Relations as a qualified substitute) for their on-site employees (laborers, workmen, drivers, equipment operators, and craftsmen) who have not previously completed such a program and are directly engaged in actual construction of the improvement (or working at a nearby or adjacent facility used for construction of the improvement). The awarded contractor and its subcontractor(s) shall require all such employees to complete this ten-hour program, pursuant to 292.675 RSMO, unless they hold documentation on their prior completion of said program. Penalties, for Non-Compliance include contractor forfeiture to the Contracting Authority in the amount of \$2,500, plus \$100 per contractor and subcontractor employee for each calendar day such employee is employed beyond the elapsed time period for required program completion under 292.675 RSMO.

(12) **BUY AMERICA REQUIREMENTS:** Construction contracts shall assure compliance with Section 165 of the Surface Transportation Assistance Act of 1982, Section 337 of the Surface Transportation and Uniform Relocation Assistance Act of 1987, 23 CFR 635.410, and the Bipartisan Infrastructure Law (2021) Build America, Buy America Act Publication L. No. 117-58 regarding Buy America provisions on the procurement of foreign products and materials. On all contracts involving Federal-aid, all products of iron, steel, or a coating of steel which are incorporated into the work must have been manufactured in the United States. Construction materials consisting primarily of non-ferrous metals, plastic and polymer-based products, glass, lumber, or drywall also require Buy America certification. Cement and cementitious materials; aggregates such as stone, sand, or gravel; or aggregate binding agents or additives are excluded from this requirement. In addition, manufactured products are currently exempted under the 1983 waiver from FHWA. The Contracting Authority may allow minimal amounts of these materials from foreign sources, provided the cost does not exceed 0.1 percent of the contract sum or \$2,500, whichever is greater. The Contractor certifies that these materials are of domestic origin. Additional information regarding the "Buy America" requirements can be found at:

<https://www.fhwa.dot.gov/construction/cqit/buyam.cfm>

(13) **ADDENDUM ACKNOWLEDGEMENT:** The undersigned states that the all addenda (if applicable) have been received, acknowledged and incorporated into their bid, prior to submittal. For paper bids, staple addenda to the bid in the appropriate part of the bid.

(14) **SIGNATURE AND IDENTITY OF BIDDER:** The undersigned states that the following provided information is correct and that (if not signing with the intention to bind themselves to become the responsible and sole bidder) they are the agent of, and they are signing and executing this, as the bid of

_____, which is the correct LEGAL NAME as stated on the contractor questionnaire (if applicable).

a) The organization submitting this bid is a(n) (1) individual bidder, (2) partnership, (3) joint venturer (whether individuals or corporations, and whether doing business under a fictitious name), or (4) corporation. Indicate by marking the appropriate box below.

- sole individual partnership joint venture
- corporation, incorporated under laws of state of _____.

b) If the bidder is doing business under a fictitious name, indicate below by filling in the fictitious name

Executed by bidder this _____ day of _____ 20____.

THE BIDDER CERTIFIES THAT THE BIDDER AND ITS OFFICIALS, AGENTS, AND EMPLOYEES HAVE NEITHER DIRECTLY NOR INDIRECTLY ENTERED INTO ANY AGREEMENT, PARTICIPATED IN ANY COLLUSION, OR OTHERWISE TAKEN ANY ACTION IN RESTRAINT OF FREE COMPETITIVE BIDDING IN CONNECTION WITH THIS BID, AND THAT THE BIDDER INTENDS TO PERFORM THE WORK WITH ITS OWN BONAFIDE EMPLOYEES AND SUBCONTRACTORS, AND DID NOT BID FOR THE BENEFIT OF ANOTHER CONTRACTOR.

THE BIDDER ACKNOWLEDGES THAT THIS IS AN UNSWORN DECLARATION, EXECUTED UNDER PENALTY OF PERJURY UNDER THE LAWS OF THE UNITED STATES AND/OR FALSE DECLARATION UNDER THE LAWS OF MISSOURI, AND ANY OTHER APPLICABLE STATE OR FEDERAL LAWS. THE FAILURE TO PROVIDE THIS CERTIFICATION IN THIS BID MAY MAKE THIS BID NON-RESPONSIVE, AND CAUSE IT TO BE REJECTED.

THE BIDDER CERTIFIES THAT THE BIDDER'S COMPANY KNOWINGLY EMPLOYS ONLY INDIVIDUALS WHO ARE AUTHORIZED TO WORK IN THE UNITED STATES IN ACCORDANCE WITH APPLICABLE FEDERAL AND STATE LAWS AND ALL PROVISIONS OF MISSOURI EXECUTIVE ORDER NO. 07-13 FOR CONTRACTS WITH THE CONTRACTING AUTHORITY.

- Check this box ONLY if the bidder REFUSES to make any or all of these certifications. The bidder may provide an explanation for the refusal(s) with this submittal.

Signature of Bidder's Owner, Officer, Partner or Authorized Agent

Please print or type name and title of person signing here

Attest:

Secretary of Corporation if Bidder is a Corporation

Affix Corporate Seal (If Bidder is a Corporation)

NOTE: If bidder is doing business under a fictitious name, the bid shall be executed in the legal name of the individual, partners, joint ventures, or corporation, and registration of fictitious name filed with the secretary of state, as required by sections 417.200 to 417.230 RSMo. If the bidder is a corporation not organized under the laws of Missouri, it shall procure a certificate of authority to do business in Missouri, as required by section 351.572 et seq RSMo. A certified copy of such registration of fictitious name or certificate of authority to do business in Missouri shall be filed with the Missouri

Highways and Transportation Commission, as required by the standard specifications.

(15) **TRAINEES**: By submitting this bid, the bidder certifies that the bidder is familiar with the Training Provision in the Missouri Highways and Transportation Commission's "General Provisions and Supplement Specifications" which are available on the Missouri Department of Transportation web page at www.modot.mo.gov under "Business with MoDOT" "Standards and Specifications". The number of trainee hours provided under this contract will be **1 slots** at 1000 hours per slot or **1000 hours**.

(16) **SUBCONTRACTOR DISCLOSURE**: Requirements contained within Sec 102.7.8 of the Missouri Standard Specification for Highway Construction shall be waived for this contract.

(17) **PROJECT AWARD**: This project will be awarded to the lowest, responsive, responsible bidder.

(18) **MATERIALS INSPECTIONS**: All technicians who perform, or are required by the FHWA to witness, such sampling and testing shall be deemed as qualified by virtue of successfully completing the requirements of EPG 106.18 Technician Certification Program, for that specific technical area.

(19) **PRIME CONTRACTOR REQUIREMENTS**: The limitation in Sec 108.1.1 of the Missouri Standard Specifications for Highway Construction that "the contractor's organization shall perform work amounting to not less than 40 percent of the total contract cost" is waived for this contract. Instead, the less restrictive terms of the Federal Highway Administration's rule at Title 23 Code of Federal Regulations (CFR) § 635.116(a) shall apply, so that the contractor must perform project work with its own organization equal to and not less than 30 percent of the total original contract price. All other provisions in Sec 108.1.1 et seq. of the Missouri Standard Specifications for Highway Construction shall remain in full force and effect, and shall continue to govern the contractor and its subcontractors, in accordance with the provisions of Title 23 CFR § 635.116.

(20) **SALES AND USE TAX EXEMPTION**: **Jefferson County Port Authority** a tax exempt entity, will furnish a Missouri Project Exemption Certificate as described in Section 144.062 RSMo to the awarded contractor who in turn may use the certificate to purchase materials for a specific project performed for the tax exempt entity. Only the materials and supplies incorporated or consumed during the construction of the project are exempt. The certificate will be issued to the contractor for a specific project for a defined period of time.

21) (a) **INSTRUCTIONS TO BIDDERS**

ARTICLE 1

DEFINITIONS

1.1 Bidding Documents include the Invitation to Bid, Instructions to Bidders, the Bid Form and the proposed Contract Documents including any Addenda issued prior to receipt of Bids. The Contract Documents proposed for the Work consists of the Owner-Contractor Agreement, State Wage Determination, Performance and Payment Bond, the Specifications, the Drawings, the Construction Schedule, all Addenda, and all Modifications.

1.2 All definitions set forth in the General Conditions of Owner-Contractor Agreement or in other Contract Documents are applicable to the Bidding Documents.

1.3 **Addenda** are written or graphic instruments issued prior to the execution of the Owner-Contractor Agreement, which modify or interpret the Bidding Documents by additions, deletions, clarifications, or corrections.

- 1.4 A **Bid** is a complete and properly signed proposal to do the Work, or a designated portion thereof, for the sums stipulated therein, submitted in accordance with the Bidding Documents.
- 1.5 The **Base Bid** is the sum stated in the bid for which the bidder offers to perform the Work described in the Bidding Documents as the base to which work may be added or from which work may be deleted for sums stated in alternate bids.
- 1.6 An **Alternate Bid** is an amount stated in the bid to be considered in addition to the Base Bid if the corresponding Change in the Work, as described in the Bidding Documents, is accepted.
- 1.7 A **Unit Price** is an amount stated in the bid as a price per unit of measurement for materials or services as described in the Bidding Documents or in the proposed Contract Documents.
- 1.8 A **Bidder** is a person or entity who submits a bid.
- 1.9 A **Sub-Bidder** is a person or entity who submits a bid to a bidder for materials or labor for a portion of the Work.

ARTICLE 2

BIDDER'S REPRESENTATIONS

- 2.1 Each bidder by making his bid represents and warrants that:
 - 2.1.1 He has read and understands the Bidding Documents and his bid is made in accordance therewith.
 - 2.1.2 He has visited and carefully examined the site of the Work, and has familiarized himself with and satisfied himself of the following:
 1. the nature and location of the Work;
 2. the character, quality and quantity of materials to be encountered;
 3. the character and quantity of equipment and facilities needed prior to and during performance of the Work;
 4. the local conditions under which the Work is to be performed, including the availability of necessary labor;
 5. the requirements for maintaining existing facilities in continuous service, if necessary or required.
- 2.13 He has correlated his examination and observations with the requirements of the proposed Contract Documents.
- 2.14 His bid is based upon the materials, products, systems and equipment required by the Bidding Documents.

ARTICLE 3

BIDDING DOCUMENTS

- 3.1 **COPIES**
 - 3.1.1 Bidders may obtain digital copies of the Bidding Documents in the manner as defined in the Invitation to Bid. Bidders must complete all contact information requested on the Plan Holders List to obtain the Bidding Documents.
 - 3.1.2 Each Bidder shall use a complete set of Bidding Documents in preparing his bid.
- 3.2 **INTERPRETATION OR CORRECTION OF BIDDING DOCUMENTS**

- 3.2.1 Bidders shall promptly notify the Owner in writing of any ambiguity, inconsistency or error which they may discover upon examination of the Bidding Documents or of the site and local conditions.
- 3.2.2 Bidders may request clarification or interpretation of the Bidding Documents by making a written request which shall reach the Owner at least seven (7) days prior to the date for receipt of bids. See the Invitation for Bids for contact information.
- 3.2.3 Any interpretation, correction or change of the Bidding Documents will be made by Addendum. Interpretations, corrections or changes of the Bidding Documents made in any other manner will not be binding on the Owner, and bidders shall not rely upon such interpretations, corrections and changes.
- 3.2.4 If the Owner determines that clarification of the terms and conditions of the Bidding Documents is necessary, an Addendum will be made available to all bidders setting forth such clarification.

3.3 SUBSTITUTIONS

- 3.3.1 The materials, products, systems and equipment described in the Bidding Documents establish a minimum standard of required function, dimension, appearance and quality which must be met by any proposed substitution.
- 3.3.2 No substitution of the materials, products, systems and equipment described in the Bidding Documents will be considered prior to receipt of bids unless written request for approval has been received by the Owner at least ten (10) days prior to the date for receipt of bids. Each such request shall include the name of the material, product, system or equipment for which substitution will be made and a complete description of the proposed substitute including drawings, costs, performance and test data and any other information necessary for an evaluation. A statement setting forth any changes in other materials, products, systems or equipment or other work that incorporation of the substitute would require shall be included in each such request. The Owner, in its sole discretion, may approve or disapprove the proposed substitute.
- 3.3.3 If the Owner approves any proposed substitution prior to receipt of bids, such approval will be set forth in an Addendum. Bidders shall not rely upon approvals made in any other manner.
- 3.3.4 No substitutions will be considered after the Contract is awarded unless specifically provided in the Contract Documents.

3.4 ADDENDA

- 3.4.1 Addenda will be mailed or delivered to all who are known by the Owner to have received a complete set of Bidding Documents.
- 3.4.2 Copies of Addenda will be made available for inspection wherever Bidding Documents are on file for that purpose.
- 3.4.3 3.4.3 Prior to submitting his bid, each bidder shall ascertain that he has received all Addenda issued, and he shall acknowledge receipt of all such Addenda in his bid.

ARTICLE 4

BIDDING PROCEDURE

4.1 FORM AND STYLE OF BIDS

- 4.1.1 Attached to the Contract Documents is a separate, complete set of Bid Forms to be signed and submitted as the Bidder's formal bid. To be considered, a bid shall be properly completed using these Bid Forms.

- 4.1.2 All blanks on the Bid Form shall be filled in by typewriter or legibly handwritten in ink.
- 4.1.3 Where so indicated by the make-up of the Bid Form, dollar amounts shall be expressed in both words and figures and in case of discrepancy between the two, the amount written in words shall govern.
- 4.1.4 Any interlineation, alteration or erasure must be initialed by the signer of the bid.
- 4.1.5 Where two or more bids for designated portions of the Work have been requested, the Bidder may, without forfeiture of his bid security, state his refusal to accept award of less than the combination of bids if he so stipulates. The Bidder shall make no additional stipulations on the Bid Form nor qualify his bid in any other manner.
- 4.1.6 Each copy of the bid shall include the legal name of the Bidder and a statement that the Bidder is a sole proprietor, a partnership, a corporation, or some other legal entity. Each copy shall be signed by the person or persons legally authorized to bind the bidder to a contract. A bid submitted by an agent shall have a current power of attorney attached certifying the agent's authority to bind the Bidder.
- 4.1.7 The Owner shall not be responsible in any way for any costs or expenses related to the preparation or submission of any bid.

4.2 **BID SECURITY**

- 4.2.1 Each bid shall be accompanied by a certified check or a satisfactory bid bond executed by the bidder and an acceptable Surety company, naming the Owner as Obligee, in the amount of not less than five percent (5%) of the Base bid plus any Alternates ("Bid Security"). If the bidder fails to enter into a Contract with the Owner on the terms stated in his bid, or fails to furnish Performance and Payment Bonds as required by the Contract Documents, the amount of the Bid Security shall be forfeited to the Owner as liquidated damages, not as a penalty.
- 4.2.2 4.2.2 The Owner will have the right to retain the Bid Security of bidders to whom an award is being considered until either, (a) the Owner-Contractor Agreement has been executed and the Performance and Payment Bonds have been furnished, (b) the specified time has elapsed so that bids may be withdrawn, or (c) all bids have been rejected.

4.3 **SUBMISSION OF BIDS**

- 4.3.1 Bidders must complete and submit the following for their bid to be considered responsive:
1. A completed, signed and sealed Bid Form acknowledging receipt of all addenda, or acknowledging that there were none.
 2. A signed Subcontractor Approval Form including each proposed Subcontractor, or other persons or entities (including those who are to furnish materials or equipment fabricated to a special design) proposed for the principal portions of the Work.
 3. A signed Subcontractor Certification Regarding Affirmative Action.
 4. The Bid Security required by the Project Manual
 5. A signed E-Verify Affidavit and Memo of Understanding (MOU).
 6. Completed DBE Submittal Forms within three business days of the bid opening.
 7. A designation of the Work, item by item, including the related dollar amount and total dollar amount, to be performed by the bidder with his own forces
- 4.3.2 All copies of the bid, the Bid Security and all documents listed above that are required to be submitted with the bid shall be enclosed in a sealed envelope identified "SEALED BID ENCLOSED" on the face thereof. The envelope shall be addressed and delivered to the Owner and shall be identified with the project name, the Bidder's name and address and, if applicable, the designated portion of the Work for which the Bid is submitted. If the bid is sent by mail, the sealed envelope shall be enclosed in a separate mailing envelope with the notation "SEALED BID ENCLOSED" on the face thereof.

- 4.3.3 Bids shall be deposited at the designated location prior to the time and date for receipt of bids indicated in the Invitation to Bid or any extension thereof made by an Addendum. Bids received after the time and date for receipt of bids will be returned unopened.
- 4.3.4 The bidder shall assume full responsibility for timely delivery at the location designated for receipt of bids.
- 4.4 **MODIFICATION OR WITHDRAWAL OF BID**
- 4.4.1 A bid may not be modified, withdrawn or cancelled by the bidder within ninety (90) days following the time and date designated for the receipt of bids, and each bidder so agrees in submitting his bid.
- 4.4.2 Prior to the time and date designated for receipt of bids, any bid submitted may be modified or withdrawn by notice to the party receiving bids at the place designated for receipt of bids. Such notice shall be in writing over the signature of the bidder.
- 4.4.3 Withdrawn bids may be resubmitted up to the time designated for the receipt of bids provided that they are then fully in conformance with these Instructions to Bidders.
- 4.4.4 The amount of the Bid Security shall be in an amount sufficient for the bid as modified or resubmitted.

ARTICLE 5

CONSIDERATIONS OF BIDS

- 5.1 **OPENING OF BIDS**
- 5.1.1 Unless stated otherwise in the Invitation to Bid, the properly identified bids received on time will be opened publicly and will be read aloud.
- 5.2 **REJECTION OF BIDS**
- 5.2.1 The Owner shall have the right to reject any or all bids, to reject a bid not accompanied by the Bid Security or by other data required by the Bidding Documents, to reject a bid which is in any way incomplete or irregular, and to rebid the Work at a later date, with MoDOT concurrence, if all bids are rejected.
- 5.3 **ACCEPTANCE OF BID (AWARD)**
- 5.3.1 It is the intent of the Owner to award the Contract to the lowest responsive, responsible bidder provided the bid has been submitted in accordance with the requirements of the Bidding Documents and does not exceed the funds available. The Owner will obtain concurrence of award from MoDOT prior to awarding the Contract.
- 5.3.2 The Owner shall have the right to accept alternates and to determine the low bidder on the basis of the sum of the base bid and the alternates accepted. Alternates shall be accepted in the order established in the Bid Form Proposal.

ARTICLE 6

POST BID INFORMATION

- 6.1 **SUBMITTALS**
- 6.1.1 The bidder will be required to establish, to the satisfaction of the Owner, the reliability and responsibility of the persons or entities proposed to furnish and perform the Work.
- 6.1.2 Persons and entities proposed by the bidder and to whom the Owner has made no objection must be used on the Work for which they were proposed and shall not be changed except with the prior written consent of the Owner.

ARTICLE 7

AWARD OF CONTRACT

- 7.1 Following receipt, to the satisfaction of the Owner, of all information required under Paragraph 6.1 above, the Owner shall mail to the successful bidder the Notice of Award of the Contract.
- 7.2 Within five (5) working days from the date of receipt of the Notice of Award, the successful bidder shall execute and deliver to the Owner the Contract Documents, and shall furnish the Bonds required by Paragraph

8.1 below and the Certificates of Insurance required by Subparagraph 10.1.3 of the General Conditions. In the event the successful bidder fails to execute and deliver the Contract Documents, the Bonds and the Certificates of Insurance as aforesaid, the Owner may, at its option, consider the bidder in default and award the Contract to another bidder, in which case the Bid Security of the defaulting bidder shall be forfeited to the Owner as liquidated damages, and not as a penalty.

- 7.3 The Contract, when executed, shall be deemed to include the entire agreement between the parties thereto, and the Bidder shall not claim any modification thereof resulting from any claimed representation or promise made at any time prior thereto by any officer, agency or employee of the Owner or by any other person.

ARTICLE 8

PERFORMANCE BOND AND LABOR AND MATERIAL PAYMENT BOND

8.1 BOND REQUIREMENTS

- 8.1.1 The successful bidder shall furnish a Performance Bond in an amount equal to one hundred percent (100%) of the Contract Sum as security for the faithful performance of the Contract, and also a Labor and Material Payment Bond in an amount not less than one hundred percent (100%) of the Contract Sum as security for the payment of all persons performing labor on the project under this Contract and furnishing materials in connection with this Contract. The Surety shall be a company licensed to do business in the State of Missouri and shall be acceptable to the Owner. The Performance Bond and the Labor and Material Payment Bond may be in one or in separate instruments, however if combined into one the amount shall be for two hundred percent (200%) of the Contract Sum.

8.2 TIME OF DELIVERY AND FORM OF BONDS

- 8.2.1 The bidder shall deliver the required bonds to the Owner not later than the date of execution of the Owner-Contractor Agreement, or if the Work is to be commenced prior thereto in response to a Letter of Intent, the bidder shall, prior to commencement of the Work, submit evidence satisfactory to the Owner that such bonds will be furnished.
- 8.2.2 The bidder shall require the attorney-in-fact who executes the required bonds on behalf of the Surety to affix thereto a certified and current copy of his power of attorney.

ARTICLE 9

FORM OF AGREEMENT BETWEEN OWNER AND CONTRACTOR

9.1 FORM TO BE USED

- 9.1.1 Unless otherwise required in the Bidding Documents, the Owner-Contractor Agreement for the Work shall be in the form attached hereto.

ITEMIZED BID: The bidder should complete the following section in accordance with Sec 102.7. The bidder proposes to furnish all labor, materials, equipment, services, etc. required for the performance and completion of the work, as follows:

BID FORM PROPOSAL

PROJECT NAME: RIVERVIEW PLAZA DRIVE IMPROVEMENTS

BID TIME: 3:00 p.m.

PROJECT LOCATION: Jefferson County Port Authority

BID DATE: 12-09-2024

BIDDER NAME:

TO: The Jefferson County Port Authority

In response to the Invitation for Bids for Project No. WCI24000071, and in accordance with the Instructions to Bidders and other Bidding Documents, the undersigned Bidder declares that he has had an opportunity to examine the site of the Work and has carefully examined the Contract Documents therefore, including the Addenda identified below, and on the basis thereof, and being fully familiar with the local conditions affecting the Work, and upon written notice of award of contract, acknowledges and agrees to provide all labor, material, equipment, tools, management and supervision, safety and technical services, insurance, bonds and incidentals necessary or required for the faithful performance of the Contract Work in accordance with the above-referenced documents in a safe, timely and workmanlike manner for the following Base Bid Price:

BASE BID:

Dollars

(Amount in Words)

(\$ _____)

DETERMINATION OF LOW BIDDER. The Low Bidder will be determined by the total of the Base Bid.

DETERMINATION OF DBE PERCENTAGE. The DBE goal percentage will be based on the base bid total.

The Base Bid amount is more fully itemized as follows:

BIDDER NAME: _____

ITEMIZED BID FORM

ITEM NO.	BID ITEM	DESCRIPTION	UNIT	QUANTITY	UNIT COST	COST
1	2013000	CLEARING AND GRUBBING	LS	1		
2	2022010	REMOVAL OF IMPROVEMENTS	LS	1		
3	2029950	DEMOLITION AND REMOVAL OF BUILDINGS	LS	1		
4	2031000	CLASS A EXCAVATION	CY	17756		
5	2036000	COMPACTING EMBANKMENT	CY	7026		
6	3040504	TYPE 1 OR 5 AGGREGATE FOR BASE (4 IN. THICK)	SY	14502.5		
7	3040504T	TYPE 1 OR 5 AGGREGATE FOR BASE (4 IN. THICK)	SY	928.2		
8	3040506	TYPE 1 OR 5 AGGREGATE FOR BASE (6 IN. THICK)	SY	127.2		
9	4030101	ASPHALTIC CONCRETE MIXTURE PG 64-22 (SP125C MIX)	TON	210.6		
10	5021308	CONCRETE PAVEMENT (8 IN. NON-REINFORCED, 15 FT. JOINTS)	SY	690.6		
11	5021309	CONCRETE PAVEMENT (9 IN. NON-REINFORCED 15 FT. JOINTS)	SY	13811.9		
12	6081010	CONCRETE CURB RAMP	SY	8.5		
13	6096010A	FURNISHING TYPE 1 ROCK DITCH LINER	CY	16		
14	6096041	PLACING TYPE 1 ROCK DITCH LINER	CY	16		
15	6097000	ROCK LINING	CY	30		
16	6161005	CONSTRUCTION SIGNS	SF	200		
17	6181000	MOBILIZATION	LS	1		
18	6191000	PAVEMENT EDGE TREATMENT	LF	808		
19	6206000C	4 IN. WHITE STANDARD WATERBORNE PAVEMENT MARKING PAINT, TYPE P BEADS	LF	5599		
20	6206001C	4 IN. YELLOW STANDARD WATERBORNE PAVEMENT MARKING PAINT, TYPE	LF	5568		
21	6208064A	TEMPORARY RAISED PAVEMENT MARKER	EA	31		
22	6208076	4 IN TEMPORARY PAVEMENT MARKING PAINT	LF	1570		
23	6240103A	PERMANENT EROSION CONTROL GEOTEXTILE	SY	73		

BIDDER NAME: _____

ITEMIZED BID FORM (CONTINUED)

ITEM NO.	BID ITEM	DESCRIPTION	UNIT	QUANTITY	UNIT COST	COST
24	6274000	CONTRACTOR FURNISHED SURVEYING AND STAKING	LS	1		
25	7261024	24 IN. PIPE GROUP A	LF	98		
26	7261036	36 IN. PIPE GROUP A	LF	85		
27	7261048	48 IN. PIPE GROUP A	LF	199		
28	7320624A	24 IN. OR ALLOWED SUBSTITUTE GROUP A FLARED END SECTION	EA	2		
29	7320636A	36 IN. OR ALLOWED SUBSTITUTE GROUP A FLARED END SECTION	EA	2		
30	7320648A	48 IN. OR ALLOWED SUBSTITUTE GROUP A FLARED END SECTION	EA	2		
31	8025006	MULCHING	TON	8.3		
32	8051000A	SEEDING - COOL SEASON GRASSES	ACRE	3.3		
33	8061019	SILT FENCE	LF	2863		
34	6061060	MGS GUARDRAIL	LF	712		
35	6061069	MGS BRIDGE APPROACH TRANSITION SECTION (REGULAR/NO CURB)	EA	2		
36	6062400	BRIDGE ANCHOR SECTION (THRIE BEAM)	EA	2		
37	6063014	TYPE A CRASHWORTHY END TERMINAL (MASH)	EA	4		
38	9011030	LIGHTING POLE, 30 FT. OR 9.0 M, TYPE AT	EA	15		
39	9011312	LUMINAIRE, LED-B	EA	15		
40	9013002	CONDUIT, 2 IN. RIGID, IN TRENCH	LF	2665		
41	9014003	CONDUIT, 3 IN. RIGID, PUSHED	LF	84		
42	9017008	CABLE, 8 AWG 1 CONDUCTOR	LF	5500		
43	9017110	CABLE, 10 AWG 1 CONDUCTOR, POLE AND BRACKET	LF	980		
44	9017208	WIRE, 8 AWG, BARE NEUTRAL	LF	2750		
45	9017404	CABLE-CONDUIT, 1 IN., 2 CONDUCTORS AND 1 BARE NEUTRAL, 6 AWG	LF	20		

BIDDER NAME: _____

SAMPLE BID BOND

BID BOND

KNOW ALL PERSONS BY THESE PRESENTS, that we _____

_____ as principal and _____ as surety, are held and firmly bound unto the (Insert LPA Name) _____ in the penal sum of _____ Dollars (\$) to be paid to the commission to be credited to the state road fund, the principal and surety binding themselves, their heirs, executors, administrators, successors, and assigns, jointly and severally, firmly by these presents.

Sealed with our seals and dated this _____

THE CONDITION OF THIS OBLIGATION is such that

WHEREAS the principal is submitting herewith a bid to the commission on route(s) _____

in _____ County(ies), project (s) _____

_____ for construction or improvement of state highway as set out in said bid;

NOW THEREFORE, if the commission shall accept the bid of the principal and if the principal shall properly execute and deliver to the commission the contract, contract bond, and evidence of insurance coverage in compliance with the requirements of the bid, the specifications, and the provisions of section 227.100 RSMo, to the satisfaction of the commission, then this obligation shall be void and of no effect, otherwise to remain in full force and effect.

In the event the said principal shall, in the judgment of the commission, fail to comply with any requirement as set forth in the preceding paragraph, then the state of Missouri, acting by and through the commission, shall immediately and forthwith be entitled to recover the full penal sum above set out, together with court costs, attorney's fees, and any other expense of recovery.

The principal and surety hereby certify that the document is the original or a verbatim copy of the bid bond form furnished by the Commission, in accordance with Sec 102.9 of the Missouri Standard Specifications for Highway Construction.

Principal

SEAL

By _____

Signature

Surety

SEAL

By _____

Signature of Attorney in Fact

NOTE: This bond must be executed by the principal, and by a corporate surety authorized to conduct surety business in the state of Missouri.

SUBCONTRACTOR CERTIFICATION REGARDING AFFIRMATIVE ACTION

Project: _____
Job No. _____
Route: _____
County: _____

Certification Regarding Affirmative Action and Equal Opportunity: The bidder (prospective prime contractor) or proposed subcontractor certifies:

1. Affirmative Action Program: That it has developed and has on file at each of its establishments affirmative action programs pursuant to 41 CFR Part 60-2.
2. Equal Opportunity Clause: That it has participated in a previous contract or subcontract subject to the equal opportunity clause set forth in 41 CFR Part 69-1.4 and executive order no. 11246.
3. Compliance Reports: That it has filed with the Joint Reporting Committee, the Director of the Office of Federal Contract Compliance Programs and his designate, or The Equal Employment Opportunity Commission, all reports due under the applicable filing requirements contained in 41 CFR Part 60-1.

If the text of the certification above is incorrect, the bidder or subcontractor making the certification shall correct it below: _____

NOTE: This certification applies to and must be executed by each bidder (prospective prime contractor) or proposed subcontractor if its proposed contract or subcontract on this project will equal or exceed \$10,000 or that contractor or subcontractor has contracts or subcontracts on federally assisted projects in any 12-month period which have or can reasonably be expected to have, an aggregate total value exceeding \$10,000 41 CFR Part 60-1.5(a)(1). It is a duty and contract obligation of the prime contractor to insure that each of its subcontractors, which meet this criterion, executes and submits to the commission this certification also.

Company
By: _____

Date: _____

Title

Fig. 136.9.2 Subcontractor Certification Regarding Affirmative Action Revised 01-01-0

SUBCONTRACTOR APPROVAL FORM

This fully completed report must accompany and be part of the sealed Bid Proposal.

1 Name of Bidder: _____

2 Address of Bidder: _____

City State Zip Phone

3 The above named Bidder intends to subcontract for materials, services, supplies, specialty contractors, etc., in the following fashion:

Names and Addresses of Subcontractor Which the Contractor Anticipates Utilizing	Nature of Participation	\$ Value of Subcontractor
_____	_____	_____
_____	_____	_____
_____	_____	_____
_____	_____	_____

A. Total of Above _____

B. Total of Bid Amount _____

Subcontractor Utilization as a % of Total Bid Amount: $(A/B \times 100)$ _____

Name-Authorized Officer of Bidder

Signature-Officer of Bidder

Date

DBE Identification Submittal Form (For Local Program Agency (LPA) Projects)

Job Number: _____

Route: _____

County: _____

Prime Contractor: _____

Contract Amount: _____

Identification of Participating DBE's: Provide the requested information below for each DBE participating on the project. Submit this information with your bid or to _____ no later than 4:00 p.m. on the 3rd working day after the bid opening. Fax or e-mail transmittal is permitted. The fax number is _____ and the e-mail address for submittal is _____. Contact MoDOT's External Civil Rights Division (ECR) at (573) 526-2978 for questions and assistance on completion. **This page of this document must be received for each DBE utilized on the project.**

All information must be provided.

If awarded the contract for this project, the undersigned will use the following DBE to perform or furnish the work, supplies, and/or services as shown below:

DBE Name: : _____ Address: _____

(A) Line No.	(B) Dollar Value of DBE Work** (Unit Price x Quantity of the Item in (A), or Lump Sum)	(C) Dollar value applicable to DBE Goal** (100%, 60%)	(D) Dollar amount applicable to DBE Goal (B x C)	(E) Percent of total contract amount for line item (D / total contract amount)	Add or Remove Lines	
					-	+
					-	+
					-	+
					-	+
					-	+
					-	+
					-	+
					-	+
					-	+
					-	+
DBE Total:				Total %		

**Cannot exceed contract amount for given item of work
 Trucking services credited at 100% if the DBE owns the trucks or is leasing from a DBE firm
 Allowed amount of participation will be in accordance with 49 CFR Part 26.
 Brokered services will only receive credit for fees.

Respectfully submitted:

Company Name (Prime Contractor)

Name / Title

Signed (Prime Contractor)

**Instructions for Completing the
DBE Identification Submittal
Form
(For Local Program Agency (LPA) Projects)
(ECR-101)**

Submit this form with your bid or as outlined on front of page no later than 4:00 p.m. on the 3rd working day after the bid opening. Only DBE's listed on MoDOT's Missouri Regional Certification Committee (**MRCC**) directory may be used towards obtaining the DBE goal on the project. DBE firm must be certified with the appropriate North American Industrial Classification System (**NAICS**) code for the type of work being utilized to perform. The MRCC directory is available at the following link under the MRCC Directory tab: [HTTP://www.modot.org/welcome-external-civil-rights](http://www.modot.org/welcome-external-civil-rights)

- (A) Insert Bid Line Item in the same order as it appears in the bid document.
- (B) Insert the result from multiplying the unit price for the bid line item by the quantities listed in column (A); a lump sum, if applicable, may also be inserted.
- (C) Insert the percentage of column (B) that the DBE will perform. If the DBE is a supplier as that term is defined in 49 CFR Part 26.55, then only 60% of the value in column (B) can be applied towards the contract specific goal. If the DBE is furnishing and installing the line item, then 100% of the value can be applied.
- (D) Insert the result from dividing columns (B) and (C).
- (E) Insert the result from dividing column (D) from the total bid line item amount.

DISADVANTAGED BUSINESS ENTERPRISE (DBE) PROGRAM REQUIREMENTS
for Local programs

1.0 Disadvantaged Business Enterprise (DBE) Program Requirements. The subsequent Sections will apply only to contracts involving U.S. Department of Transportation (USDOT) federal-aid or federal financial participation. Federal-aid or federal financial participation includes, but is not limited to, any funds directly or indirectly received by MoDOT, or authorized for distribution to or through MoDOT, by the USDOT or any operating administration within the USDOT. These provisions will not apply to Commission contracts funded exclusively with state funds, or state and local funds. Any contractor, subcontractor, supplier, DBE firm, and contract surety involved in the performance of a federal-aid contract shall be aware of and fully understand the terms and conditions of the USDOT DBE Program, as the terms appear in Title 49 CFR Part 26 (as amended), the USDOT DBE Program regulations; Title 7 CSR Division 10, Chapter 8 (as amended), the Commission's DBE Program rules.

2.0 DBE Program Distinguished From Other Affirmative Action Programs. The USDOT DBE Program established by the U.S. Congress is not the same as, and does not involve or utilize, any of the elements or authority of other state or local affirmative action programs, nor does the program rely upon state legislation or gubernatorial executive orders for implementation or authorization, other than the general authority given the Commission in Section 226.150, RSMo. The USDOT DBE Program is implemented by the Commission and MoDOT, through and in conjunction with the FHWA, FTA and FAA, as a "recipient" defined in Title 49 CFR 26.5.

3.0 Policy Regarding DBE Firms. It is the policy of the U. S. Department of Transportation and MoDOT that businesses owned by socially and economically disadvantaged individuals have an opportunity to participate in the performance of contracts financed in whole or in part with federal funds. Consequently, the requirements of 49 CFR Part 26 (as amended) and the Commission's implementing state regulations in Title 7 CSR Division 10, Chapter 8, "Disadvantaged Business Enterprise Program", will apply to any contract with federal funds.

4.0 Opportunity for DBEs to Participate. Each contractor, subcontractor and supplier working on a contract financed in whole or in part with federal funds shall take all necessary and reasonable steps to ensure that DBEs have an opportunity to compete for, and participate in performance on project contracts and subcontracts.

5.0 Required Contract Provision. The federal-aid contract will include the following provision, as mandated by USDOT at Title 49 CFR 26.13(b):

(a) The contractor, subrecipient or subcontractor shall not discriminate on the basis of race, color, national origin, or sex in the performance of the contract. The contractor shall carry out applicable requirements of 49 CFR Part 26 in the award and administration of USDOT-assisted contracts. Failure by the contractor to carry out these requirements is a material breach of the contract, which may result in the termination of the contract or such other remedy, as the recipient deems appropriate.

In this provision, "contractor" will be defined as the contractor on the contract; "subrecipient" will be defined as any subcontractor performing the work. For the purposes of any federal-aid contract awarded by the Commission, "the recipient" will be defined as either the Commission, or MoDOT, or both. The contractor shall include this same contract provision in every supply contract or subcontract the contractor makes or executes with a subrecipient.

6.0 Bank Services. The contractor, and each subrecipient on a federal-aid contract, is encouraged to use the services of banks owned and controlled by socially and economically disadvantaged individuals. Such banking services, and the fees charged for services, typically will not be eligible for DBE Program contract goal credit. Any questions on this subject should be directed to the MoDOT External Civil Rights Director. See Sec 7.0.

7.0 DBE Program Information. DBE Program information may be obtained from the MoDOT External Civil Rights Director, P.O. Box 270, Jefferson City, Missouri 65102-0270. Phone (573) 751-4309, Fax (573) 526-0558, E-Mail: dbe@modot.mo.gov. It will be the duty of each contractor, for the contractor and for the contractor's subrecipients and surety, to take the steps necessary to determine the legal obligations and limitations under the DBE Program, as an element of responsibility. It will be the duty of each certified DBE firm to know, understand and comply with the DBE firm's legal obligations and limitations under the DBE Program, as a requirement of program participation. A surety providing a bid or contract bond will be bound by those bonds to the duties of the surety's principal.

8.0 DBE Certification, and the Missouri Unified Certification Program. The Missouri Department of Transportation and other certifying agencies within Missouri have partnered to form the Missouri Regional Certification Committee (MRCC) and developed a Unified Certification Program (UCP) pursuant to 49 CFR 26.81 and 7 CSR 10-8.061. Only DBE firms certified by the MRCC are eligible to perform work on a federal-aid contract for DBE contract goal credit. It is the contractor's responsibility to ensure firms identified for participation are approved certified DBE firms.

The MRCC DBE Directory can be found at the following link:

http://www.modot.mo.gov/business/contractor_resources/External_Civil_Rights/DBE_program.htm

9.0 DBE Program-Related Certifications Made By Bidders and Contractors. If the bidder makes a written, express disclaimer of one or more certifications or assurances in the bid, the bid will be considered non-responsive. By submitting a bid on any call involving USDOT federal financial participation, and by entering into any contract on the basis of that bid, the contractor makes each of the following DBE Program-related certifications and assurances to USDOT, to the Commission, and to MoDOT:

(a) The bidder certifies that management and bidding officers have reviewed and understand the bidding and project construction and administration obligations of the USDOT DBE Program regulations at Title 49 CFR Part 26 (as amended), the USDOT DBE Program regulations; Title 7 CSR Division 10, Chapter 8 (as amended), and the Commission's DBE Program rules. The bidder further certifies that the contractor's management personnel on the project understand and are familiar with the requirements of these federal and state DBE Program regulations; and if the bidder was not familiar with or did not understand the requirements of these regulations, they have contacted the External Civil Rights Division of MoDOT and have been informed as to their duties and obligations under the DBE Program regulations by MoDOT staff and/or by USDOT DBE Program staff.

(b) The bidder certifies that the bidder has complied with the federal and state DBE Program requirements in submitting the bid, and will comply fully with these requirements in performing any federal-aid contract awarded on the basis of that bid.

(c) The bidder agrees to ensure that certified DBE firms have a full and fair opportunity to participate in the performance of the contract financed in whole or in part with federal funds. The bidder certifies that all necessary and reasonable steps were taken to ensure that DBE firms have an opportunity to compete for, and perform work on the contract. The bidder further certifies that the bidder not discriminate on the basis of race, color, age, national origin or sex in the performance of the contract, or in the award of any subcontract.

(d) The bidder certifies, under penalty of perjury and other applicable penal laws that if awarded the federal-aid contract, the contractor will make a good faith effort to utilize certified DBE firms to perform DBE work at or above the amount or percentage of the dollar value specified in the bidding documents. The bidder further certifies the bidder's understanding that the bidder may not unilaterally terminate, substitute for, or replace any DBE firm that was designated in the executed contract, in whole or in any part, with another DBE, any non-DBE firm or with the contractor's own forces or those of an affiliate of the contractor, without the prior written consent of MoDOT as set out below.

(e) The bidder certifies, under penalty of perjury and other applicable penal laws that a good faith effort was made to obtain DBE participation in the contract, at or above the DBE participation contract goal. The bidder further certifies, under penalty of perjury and other applicable penal laws, that if the bidder is not able to meet the Commission's DBE contract goal, and if the bidder is not able to meet that DBE contract goal by the time the proposed DBE participation information must be submitted, within three business days after bid opening, the bidder has submitted with and as a part of the bid, a true, accurate, complete and detailed written explanation of good faith efforts to meet the DBE Contract Goal.

(f) The bidder understands and agrees that if awarded the contract the contractor is legally responsible to ensure that the contractor and each DBE subcontractor and supplier, comply fully with all regulatory and contractual requirements of the USDOT DBE Program, and that each DBE firm participating in the contract fully perform the designated tasks, with the DBE's own forces and equipment, under the DBE's own direct supervision and management. The bidder certifies, under penalty of perjury and other applicable penal laws, that if it awarded the contract and if MoDOT or the Commission determine that the contractor, a DBE or any other firm retained by the contractor has failed to comply with the DBE Program requirements or federal or state DBE Program regulations, the Commission, through MoDOT, shall have the sole authority and discretion to determine the extent of the monetary value to which the DBE contract goals have not been met, and to assess against and withhold monetary damages from the contractor in the full amount of that breach. The Commission, through MoDOT, may impose any other remedies available at law or provided in the contract in the event of a contract breach. The bidder further understands and agrees that this clause authorizes the Commission, through MoDOT, to determine and fix the extent of the damages caused by a breach of any contractual or regulatory DBE Program requirement and that the damage assessment will be enforced in addition to, and not in lieu of, any other general liquidated damages clause in the contract. By submitting a bid for a federal-aid contract, and by entering into a contract, the bidder irrevocably agrees to such an assessment of liquidated damages for DBE Program purposes, and authorizes the Commission and MoDOT to make such an assessment of liquidated damages against the contractor, and to collect that assessment from any sums due the contractor under the contract, or any other contract, or by other legal process. The bidder makes this certification, agreement and authorization on behalf of itself, its subcontractors and suppliers, and the bid bond and contract bond sureties, for each federal-aid contract.

(g) The surety upon any bid or contract bond acknowledges the surety is held and firmly bound to the Local Agency for each and every duty of the surety's principal provided in any bid or contract regarding the DBE program.

10.0 Designation of DBE firms to perform on contract The bidder states and certifies, under penalty of perjury or other applicable penal laws, that the DBE participation information submitted in the bid or within the stated time thereafter is true, correct and complete and that the information provided includes the names of all DBE firms that will participate in the contract, the specific line item (s) that each DBE firm will perform, and the creditable dollar amounts of the participation of each DBE. The specific line item must reference the MoDOT line number and item number contained in the proposal. The bidder further states and certifies that the bidder has committed to use each DBE firm listed for the work shown to meet the DBE contract goal and that

each DBE firm listed has clearly confirmed that the DBE firm will participate in and perform the work, with the DBE's own forces. Award of the contract will be conditioned upon meeting these and other listed requirements of 49 CFR 26.53.

(a) The bidder certifies the bidder's understanding that as the contractor on a contract funded in whole or in part by USDOT federal funds, the bidder may not unilaterally terminate, substitute for, or replace any DBE firm that was designated in the executed contract, in whole or in any part, with another DBE, any non-DBE firm or with the contractor's own forces or those of an affiliate, without the prior written consent of MoDOT. The bidder understands it must receive approval in writing from MoDOT for the termination of a DBE firm, or the substitution or replacement of a DBE before any substitute or replacement firm may begin work on the project in lieu of the DBE firm participation information listed in the executed contract,

(1) The bidder further certifies understanding, that if a DBE firm listed in the bid or approved in the executed contract documents ceases to be certified at any time during the performance of the contract work, and a contract or subcontract with that firm has not yet been executed by the prime and subcontractor, the contractor can not count any work performed by that firm after the date of the firm's loss of eligibility toward meeting the DBE contract goal. However, if the contractor has executed a subcontract with the firm before the DBE lost eligibility and ceased to be a certified DBE, the contractor may continue to receive credit toward the DBE contract goal for that firm's work.

(2) The bidder further certifies understanding, that if a DBE subcontractor is terminated, or fails, refuses or is unable to complete the work on the contract for any reason, the contractor must promptly request authority to substitute or replace that firm. The request shall include written documentation that the DBE firm is unwilling or unable to perform the specified contract work. The contractor shall make good faith efforts to find another DBE subcontractor to substitute or replace the dollar amount of the work that was to have been performed by the DBE firm. The good faith efforts shall be directed at finding another DBE to perform the same, or more, dollar amount of work that the DBE firm that was terminated was to have performed under the executed contract. The substitute or replacement DBE firm may be retained to perform the same or different contract work from that which the terminated firm was to have performed. The contractor shall obtain approval from MoDOT in writing before the replacement or termination of one firm with another before the work will count toward the project DBE goal.

(3) The bidder further certifies the bidder's understanding, that the dollar value of any work completed by a DBE firm prior to approval of the DBE's substitution or replacement, in writing, by MoDOT will not be credited toward meeting the DBE contract goal. The contractor will remain subject to appropriate administrative remedies, including but not limited to, liquidated damages for the full dollar amount that the DBE contract goal is not met. Liquidated damages will also be assessed against the contractor if the original, substitute or replacement DBE firms perform the required contract work, but are not paid in full for some or all of that work by the contractor, including back charges. No credit toward the DBE goal will be given for any amount withheld from payment to the DBE or "back charged" against monies owed to the DBE, regardless of the purpose or asserted debt.

11.0 Good Faith Effort to Secure DBE Services. The bidder shall make a good faith effort to seek DBEs in a reasonable geographic area to where the solicitation for subcontracts and material is made. If the bidder cannot meet the goals using DBEs from that geographic area, the bidder shall, as a part of the effort to meet the goal, expand the search to a wider geographic area.

11.1 Bidding Procedure. The following bidding procedure shall apply to the contract, for DBE program compliance purposes.

11.2 Contract Goal, Good Faith Efforts Specified. The bidder may submit the completed "DBE Identification Submittal" information in the bid documents at the same time as, and within the sealed bid, at the time the bid is submitted. However, if that information is not completed and submitted with the initial sealed bid, then as a matter of responsiveness and responsibility, the apparent low and second low bidder shall file the completed "DBE Identification Submittal" pages to the Local Agency on or before 4:00 p.m. of the third business day after the bid opening date. The Local Agency may permit telefax transmittal. The complete and signed original documents shall be mailed to the Local Agency no later than the day of the telefax transmission. No extension of time will be allowed for any reason. The means of transmittal and the risk of timely receipt of the information shall be the bidder's.

The bidder is responsible to ensure that all submittals are checked for accuracy. Any and all omissions, deletions, and/or errors that may affect the end result of the bid package are the sole liabilities of the bidders. The bid may be found non-responsive if the submittal is not complete and/or accurate.

11.3 Bid Rejection, Bid Security Disposition. The failure of either the apparent low bidder or the second low bidder to file the completed and executed "DBE Identification Submittal", listing actual, committed DBE participation equal to or greater than the DBE contract goal percentage specified in the bid by 4:00 p.m. on the third business day after the bid opening, will be cause for rejection of that bid, and the bid surety bond or bid guaranty of that bidder will be forfeited to and become the property of the Local Agency upon demand.

(a) Any bidder rejected for failure to submit the completed and executed "DBE Identification Submittal" information in the bidding documents, with full documentation of sufficient DBE participation to satisfy the DBE contract goal cannot submit a bid on the same, or substantially similar, project, when and if the project is re-advertised for bids. By submitting a bid on a federal-aid

project, the bidder accepts and agrees to this provision, and the disposition of the bidders bid bond or guaranty, on behalf of the bidder and the bidders bid surety or guaranty.

(b) The surety separately acknowledges the surety to be held and firmly bound to the Local Agency to immediately upon demand pay the face amount of the bid bond.

11.4 Good Faith Efforts Described. Good faith efforts to meet the DBE contract goal may include, but are not limited to, the following:

(a) Attending a pre-bid meeting, if any, scheduled by the department to inform DBEs of contracting and subcontracting opportunities;

(b) Advertising in general circulation trade association and socially and economically disadvantaged business directed media concerning subcontracting opportunities.

(c) Providing written notice to a reasonable number of specific DBEs so that the DBE's interest in the contract are solicited in sufficient time to allow the firm to participate effectively;

(d) Following-up on initial written notice or solicitations of interest by contacting DBEs to determine with certainty whether the DBEs were interested.

(e) Maintaining documentation of responses received in the effort to solicit DBE participation.

(f) Selecting portions of work to be performed by DBEs to increase the likelihood of meeting the DBE goal, including, where appropriate, breaking down contracts into economically feasible units to facilitate DBE participation.

(g) Providing interested DBEs adequate information about plans, specifications and requirements of the contract.

(h) Negotiating in good faith with interested DBEs, not rejecting DBEs as unqualified without sound business reasons based on a thorough investigation of the DBE's capabilities.

(i) Making efforts to assist interested DBEs in obtaining bonding, lines of credit or insurance required by the Local Agency or by the bidder.

(j) Making effective use of available disadvantaged business organizations, minority bidders' groups, local, state and federal disadvantaged business assistance offices, MoDOT and other organizations that provide assistance in the recruitment and placement of DBEs.

11.5 Documentation, and Administrative Reconsideration of the Bidder's Good Faith Efforts. In the bidding documents, the bidder has the opportunity and responsibility to provide certified written documentation as to whether the bidder made a good faith effort to meet the DBE contract goal as proposed by MoDOT. Any bidder that has not met the Commission's proposed DBE contract goal at the time of bid opening must submit the completed "Certification of Good Faith Efforts to Obtain DBE Participation". The certification should be included in the bidding documents, fully and in detail, at the time its sealed bid is submitted, however, if that information is not completed and submitted with the initial sealed bid, the bidder must submit the documentation to the Local Agency on or before 4:00 p.m. of the third business day after the bid opening date. The Local Agency may permit telefax transmittal. The complete and signed original documents shall be mailed to the Local Agency no later than the day of the telefax transmission. No extension of time will be allowed for any reason. The means of transmittal and the risk of timely receipt of the information shall be the bidder's responsibility. The bidder shall attach additional pages to the certification, if necessary, in order to fully detail specific good faith efforts made to obtain certified DBE firm participation in the proposed contract work. If the apparent low bidder appears to have failed to adequately document in the bid that the bidder made a good faith effort to achieve sufficient DBE participation in the contract work, that firm will be offered the opportunity for administrative reconsideration upon written request, before the Local Agency and MoDOT reject that bid as non-responsive. However, regardless of the DBE contract goal participation level proposed by the bidder, or the extent of good faith efforts shown, the apparent low and second low bidders shall each timely and separately file their completed and executed "DBE Identification Submittal" or face potential sanctions and the bid bond or guaranty, as specified in Sec 10.0 of these provisions may become the property of the Local Agency subject to the Local Agency's demand.

12.0 DBE Participation for Contract Goal Credit. DBE participation on the contract will count toward meeting the DBE contract goal as follows:

(a) The applicable percentage of the total dollar value of the contract or subcontract awarded to the DBE will be counted toward meeting the DBE contract goal, only if that firm is certified by the MRCC as a DBE at the time the contract or subcontract is executed, and only for the value of the work, goods or services that are actually performed, or provided, by the DBE firm itself.

(b) When a DBE performs work as a participant in a joint venture, the contractor may count toward the DBE goal only that portion of the total dollar value of the contract equal to the distinct, clearly defined portion of the contract work that the DBE has performed with the DBE's own forces. The MoDOT External Civil Rights Director shall be contacted in advance regarding any joint venture involving both a DBE firm and a non-DBE firm to review and approve the contractor's organizational structure and proposed operation. When a DBE subcontracts part of the work of the contract to another firm, the value of that subcontracted work may be counted toward the DBE contract goal only if the DBE's subcontractor at a lower tier is a MoDOT certified DBE. Work that a DBE subcontracts to a non-DBE firm will not count toward the DBE contract goal. The cost of supplies and equipment a DBE subcontractor purchases or leases from the prime contractor or the prime's affiliated firms, or from another non-DBE subcontractor, will not count toward the DBE contract goal.

(c) The contractor may count expenditures to a DBE subrecipient toward the DBE contract goal only if the DBE performs a commercially useful function (CUF) on that contract.

(d) A contractor may not count the participation of a DBE subcontractor toward the contractor's final compliance with the contractor's DBE contract goal obligations until the amount being counted has actually been paid to the DBE. A contractor may count 60 percent of the contractor's expenditures actually paid for material and supplies obtained from a DBE certified by MoDOT as a regular dealer, and 100 percent of such expenditures actually paid for materials and supplies obtained from a certified DBE manufacturer.

(1) A regular dealer will be defined as a firm that owns, operates, or maintains a store, warehouse or other establishment in which the material, supplies, articles or equipment required and used under the contract are bought, kept in stock, and regularly sold or leased to the public in the usual course of business. To be a regular dealer, the DBE firm shall be an established, regular business that engages, as its principal business and under its own name, in the purchase and sale or lease of the products in question. Packers, brokers, manufacturers' representatives, or other persons who arrange or expedite transactions will not be considered regular dealers.

(2) A DBE firm may be a regular dealer in such bulk items as petroleum products, steel, cement, gravel, stone or asphalt, without owning, operating or maintaining a place of business where it keeps such items in stock, if the DBE both owns and operates distribution equipment for the products it sells and provides for the contract work. Any supplementation of a regular dealer's own distribution equipment shall be by a long-term lease agreement, and not on an ad hoc or contract-by-contract basis.

(3) If a DBE regular dealer is used for DBE contract goal credit, no additional credit will be given for hauling or delivery to the project site goods or materials sold by that DBE regular dealer. Those delivery costs shall be deemed included in the price charged for the goods or materials by the regular dealer, who shall be responsible for their distribution.

(4) A manufacturer will be defined as a firm that operates or maintains a factory or establishment that produces on the premises, the material, supplies, articles or equipment required under the contract and of the general character described by the project specifications. A manufacturer will include firms that produce finished goods or products from raw or unfinished material, or that purchases and substantially alters goods and materials to make them suitable for construction use before reselling them.

(e) A contractor may count toward the DBE contract goal the following expenditures to certified DBE firms that are not "regular dealers" or "manufacturers" for DBE program purposes:

(1) The contractor may count toward the DBE contract goal the entire amount of fees or commissions charged by a certified DBE firm for providing a bona fide service, such as professional, technical, consultant or managerial services, or for providing bonds or insurance specifically required for the performance of the federal-aid contract, if the fee is reasonable and not excessive, compared with fees customarily charged for similar services.

(2) The contractor may count toward the DBE contract goal the entire amount of that portion of the construction contract that is performed by the DBE's own forces and equipment, under the DBE's supervision. This includes the cost of supplies and material ordered and paid for by the DBE for contract work, including supplies purchased or equipment leased by the DBE except supplies and equipment a DBE subcontractor purchases or leases from the prime contractor or its affiliates.

(f) A contractor may count toward the DBE contract goal 100 percent of the fees paid to a certified DBE trucker or hauler for delivery of material and supplies required on a job site, but not for the cost of those materials or supplies themselves, or for the removal or relocation of excess material from or at the job site, when the DBE certified trucking company is not also the manufacturer of or a regular dealer in those material and supplies, provided that the trucking or hauling fee is determined by MoDOT to be reasonable as compared with fees customarily charged by non-DBE firms for similar services. The certified DBE trucking firm shall also perform a CUF on the project and not operate merely as a pass through for the purposes of gaining credit toward the contract DBE goal. Prior to submitting a bid, the contractor shall determine, or contact the MoDOT External Civil Rights Director for assistance in determining, whether a DBE trucking firm will meet the criteria for performing a CUF on the project.

(g) The contractor will receive DBE contract goal credit for the fees or commissions charged by and paid to a DBE broker who arranges or expedites sales, leases or other project work or service arrangements, provided that those fees are determined by MoDOT to be reasonable and not excessive, as compared with fees customarily charged by non-DBE firms for similar services. A broker will be defined as a person or firm that does not own or operate the delivery equipment necessary to transport materials, supplies or equipment to or from a job site; a broker typically will not purchase or pay for the material, supplies or equipment, and if the broker does purchase or pay for those items, those costs will be reimbursed in full. In most instances, the broker is merely the entity making arrangements for delivery of material, supplies, equipment, or arranging project services. To receive DBE contract goal credit, MoDOT must determine that the DBE broker has performed a CUF in providing the contract work or service.

13.0 Performing a Commercially Useful Function (CUF). No credit toward the DBE contract goal will be allowed for contract payments or expenditures to a DBE firm, if that DBE firm does not perform a CUF on that contract. A DBE performs a CUF when the DBE is solely responsible for execution of a distinct element of the contract work, and the DBE actually performs, manages and supervises the work involved with the firm's own forces. To perform a CUF, the DBE alone shall be responsible, and alone must bear the risk, for the material and supplies used on the contract, selecting a supplier or dealer from those available, negotiating price, determining quality and quantity, ordering the material and supplies, installing those materials with the DBE's own forces and equipment and paying for those materials and supplies. The amount the DBE firm is to be paid under the contract shall be commensurate with the work the DBE actually performs and the DBE credit claimed for the DBE's performance.

13.1 Contractor's Obligation to Monitor CUF Performance. It shall be solely the contractor's responsibility to ensure that all DBE firms perform a CUF. Further, the contractor is responsible to, and shall ensure that each DBE firm fully performs the DBE's designated tasks, with the DBE's own forces and equipment, under the DBE's own direct supervision and management. MoDOT is under no obligation to warn the contractor that a DBE's participation may not count toward the goal, other than through official notification with an opportunity for administrative reconsideration at the conclusion of the contract work.

13.2 DBEs Must Perform a Useful and Necessary Role in Contract Completion. A DBE does not perform a commercially useful function if the DBE's role is limited to that of an extra participant in a transaction, contract, or project through which funds are passed in order to obtain the appearance of DBE participation.

13.3 DBEs Must Perform The Contract Work With Their Own Workforces. If a DBE does not perform and exercise responsibility for at least 30 percent of the total cost of the DBE's contract with the DBE's own work force, or the DBE subcontracts a greater portion of the work of a contract than would be expected on the basis of normal industry practice for the type of work involved, MoDOT will presume that the DBE is not performing a commercially useful function.

13.4 Factors Used to Determine if a DBE Trucking Firm is Performing a CUF. The following factors will be used to determine whether a DBE trucking company is performing a commercially useful function (CUF):

(a) To perform a CUF, the DBE trucking firm shall be completely responsible for the management and supervision of the entire trucking operation that the DBE is being paid for on the contract work. There shall not be contrived arrangement, including but not limited to, any arrangement that would not customarily exist under regular construction project subcontracting practices for the purpose of meeting the DBE contract goal.

(b) The DBE must own and operate at least one fully licensed, insured and operational truck used in performance of the contract work. This does not include a supervisor's pickup truck or a similar vehicle that is not suitable for hauling the necessary materials or supplies.

(c) The DBE receives 100 percent contract goal credit for the total reasonable amount the DBE is paid for the transportation services provided on the contract using trucks the DBE owns, insures and operates, using drivers that the DBE employs.

(d) The DBE may lease trucks from another DBE firm, including an owner-operator who is certified as a DBE. The DBE firm that leases trucks from another DBE will receive credit for the total fair market value actually paid for of the transportation services the lessee DBE firm provides on the contract.

(e) The DBE may also lease trucks from a non-DBE firm, including an owner-operator. However, the DBE who leases trucks from a non-DBE is entitled to DBE contract goal credit only for the brokerage fee or commission the DBE receives as a result of the lease arrangement. The DBE will not receive credit for the total value of the transportation services provided by the non-DBE lessee. Furthermore, no DBE contract goal credit will be allowed, even for brokerage fees or commissions, where the DBE leases the trucks from the contractor on the project or a firm owned, controlled by, or affiliated by ownership or control to, the contractor.

(f) For purposes of this section, the lease shall indicate that the DBE firm leasing the truck has exclusive use of and control over the truck. This will not preclude the leased truck from working for others during the term of the lease with the consent of the DBE, provided the lease gives the DBE absolute priority for and control over the use of the leased truck. Leased trucks shall display the name and identification number of the DBE firm that has leased the truck at all times during the life of that lease.

13.5 MoDOT Makes Final Determination On Whether a CUF Is Performed. MoDOT and the Commission will have the final authority to determine whether a DBE firm has performed a CUF on a federal-aid contract. To determine whether a DBE is performing or has performed a CUF, MoDOT will evaluate the amount of work subcontracted by that DBE firm or performed by other firms, and the other firms forces and equipment. Any DBE work performed by the contractor, or by employees or equipment of the contractor will be subject to disallowance under the DBE Program, unless the independent validity and need is demonstrated.

14.0 Use of Joint Checks

Request for joint checks must be made to MoDOT by the contractor. Prior approval must be given before the use of joint checks is allowed. Contact External Civil Rights Division at 573-751-4309 or db@modot.mo.gov to request a Joint Check Request Form.

15.0 Verification of DBE Participation, Liquidated Damages.

15.1 Prior to final payment by the Local Agency, the contractor shall file with the Local Agency a detailed list showing each DBE used on the contract work, and the work performed by each DBE. The list shall show the actual dollar amount paid to each DBE for the creditable work on the contract, less any rebates, kickbacks, deductions, withholdings or other repayments made. The list shall be certified under penalty of perjury, or other law, to be accurate and complete. MoDOT and the Commission will use this certification and other information available to determine if the contractor and the contractor's DBEs satisfied the DBE contract goal percentage specified in the contract and the extent to which the DBEs were fully paid for that work. The contractor shall acknowledge, by the act of filing the detailed list, that the information is supplied to obtain payment regarding a federal participation contract.

15.2 Failure on the part of the contractor to achieve the DBE participation to which the contractor committed in the contract may result in liquidated damages being imposed on the contractor by the Commission for breach of contract and for non-compliance. If the contract was awarded with less than the original DBE contract goal proposed by the Commission, the revised lower amount shall become the final DBE contract goal, and that goal will be used to determine any liquidated damages to be assessed. Additionally, the Commission or MoDOT may impose any other administrative sanctions or remedies available at law or provided by the contract in the event of breach by the contractor by failing to satisfy the contractor's DBE contract goal commitment. However, no liquidated damages will be assessed, and no other administrative sanctions or remedies will be imposed when, for reasons beyond the control of the contractor and despite the good faith efforts made by the contractor, the final DBE contract goal participation percentage was not achieved. The contractor will be offered the opportunity for administrative reconsideration of any assessment of liquidated damages, upon written request. The administrative reconsideration officer may consider all facts presented, including the legitimacy or business reason for back charges assessed against a DBE firm, in determining the final amount of liquidated damages.

16.0 Prompt Payment Requirements. In accordance with Title 49 CFR 26.29, the contractor shall comply with the prompt payment requirements of that regulation, Section 34.057, RSMo., the provisions of the Commission's rule 7 CSR 10-8.111 and the contract. By bidding on a federal-aid contract, and by accepting and executing that contract, the contractor agrees to assume these contractual obligations, and to bind the contractor's subrecipients contractually to those prompt payment requirements at the contractor's expense.

17.0 Miscellaneous DBE Program Requirements. In accordance with Title 49 CFR Part 26 and the Commission's DBE Program rules in Title 7 CSR Division 10, Chapter 8, the contractor, for both the contractor and for the contractor's subcontractors and suppliers, whether DBE firms or not, shall commit to comply fully with the auditing, record keeping, confidentiality, cooperation and anti-intimidation or retaliation provisions contained in those federal and state DBE Program regulations. By bidding on a federal-aid contract, and by accepting and executing that contract, the contractor agrees to assume these contractual obligations, and to bind the contractor's subrecipients contractually, at the contractor's expense.

OWNER-CONTRACTOR AGREEMENT

THIS AGREEMENT, made and entered into by and between the _____,
(hereinafter referred to as the Owner) and _____
of _____, (herein referred to as the Contractor).

WITNESSETH: That for and in consideration of the acceptance of Contractor's bid and the award of this contract to said Contractor by the Owner and in further consideration of the agreements of the parties herein contained, to be well and truly observed and faithfully kept by them, and each of them, it is agreed between the parties as follows, to wit:

The Contractor at its own expense hereby agrees to do or furnish all labor, materials, and equipment called for in the proposal designated and marked:

and agrees to perform all the work required by the contract as shown on the plans and specifications. The "Notice to Contractor," "Plans," "Proposal," "Contract Bond," "Acknowledgment," "Notice to Proceed", and all change orders are made a part hereof as fully as set out herein.

It is understood and agreed that, except as may be otherwise provided for by "Job Special Provisions," "General Provisions," and "Supplemental Specifications," included in the Proposal, the work shall be done in accordance with the most current "Missouri Standard Specifications for Highway Construction" and "Missouri Standard Plans for Highway Construction", including all revisions to these documents, which are part and parcel of this contract, and are incorporated in this contract as fully and effectively as if set forth in detail herein.

The Contractor further agrees that it is fully informed regarding all of the conditions affecting the work to be done, and labor and materials to be furnished for the completion of this contract, and that its information was secured by personal investigation and research and not from any estimates of the Owner; and that it will make no claim against the Owner by reason of estimates, tests, or representation of any officer, agent, or employees of the Owner.

The said Contractor agrees further to begin work not later than the authorization date in the Notice to Proceed and to complete the work within the time specified in the proposal or such additional time as may be allowed by the engineer under the contract.

The work shall be done to complete satisfaction of the Engineer of the Owner and, in case the Federal Government or any agency thereof is participating in the payment of the cost of construction of the work, shall also be subject to inspection and approval at all times by the proper agent or agents of such government agency.

The parties hereto agree that this contract in all things shall be governed by the laws of the State of Missouri.

The Contractor agrees that it will comply with all federal and state laws and regulations and local ordinances and that it will comply and cause each of its subcontractors, if any, to comply with all federal and state laws and federal regulations and directives pertaining to nondiscrimination against any person on the ground of race, color, religion, creed, sex, age, ancestry, or national origin in connection with this contract, including procurement of materials and lease of equipment therefore, in accordance with the special provisions on that subject attached hereto, incorporated in and made a part of the contract.

The Contractor expressly warrants that it has employed no third person to solicit or obtain this contract on its behalf, or to cause or procure the same to be obtained upon compensation in any way contingent, in whole or in part, upon such procurement; and that it has not paid, or promised or agreed to pay, to any third person, in consideration of such procurement, or in compensation for services in connection therewith, any brokerage, commission, or percentage upon the amount receivable by it hereunder, and that it has not, in estimating the contract price demanded by it, included any sum by reason of any such brokerage, commission, or percentage, and that all moneys payable to it hereunder are free from obligation to other entities for services rendered, or supposed to have been rendered, in the procurement of this contract. Contractor further agrees that any breach of this warranty shall constitute adequate cause for the annulment of this contract by the Owner, and the Owner may retain to its own use from any sums due or to become due hereunder an amount equal to any brokerage, commission, or percentage so paid, or agreed to be paid

Under penalty of perjury under the laws of the United States and/or false declaration under the laws of Missouri, and any other applicable state or federal laws, the Contractor Signatory certifies that the Contractor and its officials, agents, and employees have neither directly nor indirectly entered into any agreement, participated in any collusion or otherwise taken any action in restraint of free competitive bidding in connection with this contract, and that the Contractor intends to do the work with its own bonafide employees or subcontractors and did not bid for the benefit of another contractor.

The Owner agrees to pay the Contractor in the manner and in the amount provided in the said Standard Specifications and Proposals.

IN WITNESS WHEREOF, the parties hereunto have hereunto set their hands and affixed their seals, this _____ day of _____, 20____.

[JEFFERSON COUNTY PORT AUTHORITY], acting by and through the
[Owner/Officials]

By _____
[Representative, Jefferson County Port Authority]

ATTEST: (SEAL)

[Attest Person Title Here and Printed Name]



Contractor Business Name

By _____
Authorized Contractor Signature

JOB SPECIAL PROVISIONS – TABLE OF CONTENTS

(Job Special Provisions shall prevail over Specification and/or General Provisions whenever in conflict therewith)

- A. Work Zone Traffic Management Plan
- B. Project Contact for Contractor/Bidder Questions
- C. Emergency Provisions and Incident Management
- D. Utilities
- E. Tree Clearing Restriction
- F. Order of Work
- G. ADA Compliance
- H. Liquidated Damages Specified for Winter Months
- I. Disadvantaged Business Enterprise (DBE) Program Requirements

 <p align="center">  11/01/2024 3:22:33 PM William G. Krussel MO PE-27561 </p> <p> WILLIAM G. KRUSSEL, PROFESSIONAL ENGINEER LICENCE NO. E-27561 </p>	<p align="center">Jefferson County Port Authority 114 Mississippi Avenue Crystal City, MO 63019</p>
	<p> WSP 211 N. BROADWAY, SUITE 2800 ST. LOUIS, MO 63102 CERTIFICATE OF AUTHORITY: 001444 </p>
	<p>DATE PREPARED: 11/01/2024</p>
Date:	ADDENDUM:

A. WORK ZONE TRAFFIC MANAGEMENT PLAN JSP-02-06A

1.0 Description. Work zone traffic management shall be in accordance with applicable portions of Division 100 and Division 600 of the Standard Specifications, and specifically as follows.

2.0 Traffic Management Schedule.

2.1 Traffic management schedules shall be submitted to the engineer for review prior to the start of work and prior to any revisions to the traffic management schedule. The traffic management schedule shall include the proposed traffic control measures, hours traffic control will be in place, and work hours.

2.2 The contractor shall notify the engineer prior to lane closures or shifting traffic onto detours.

2.3 The engineer shall be notified as soon as practical of any postponement due to weather, material or other circumstances.

2.4 In order to ensure minimal traffic interference, the contractor shall schedule lane closures for the absolute minimum amount of time required to complete the work. Lanes shall not be closed until material is available for continuous construction and the contractor is prepared to diligently pursue the work until the closed lane is opened to traffic.

2.5 Traffic Congestion. The contractor shall, upon approval of the engineer, take proactive measures to reduce traffic congestion in the work zone.

2.5.1 Traffic Delay. The contractor shall be responsible for maintaining the existing traffic flow through the job site during construction. If disruption of the traffic flow occurs and traffic is backed up in queues of 15 minute delays or longer, then the contractor shall review the construction operations which contributed directly to disruption of the traffic flow and make adjustments to the operations to prevent the queues from occurring again.

2.5.2 Traffic Safety.

2.5.2.1 Where traffic queues routinely extend to within 1000 feet (300 m) of the ROAD WORK AHEAD, or similar, sign on a divided highway or to within 500 feet (150 m) of the ROAD WORK AHEAD, or similar, sign on an undivided highway, the contractor shall extend the advance warning area, as approved by the engineer.

2.5.2.2 When a traffic queue extends to within 1000 feet (300 m) of the ROAD WORK AHEAD, or similar, sign on a divided highway or to within 500 feet (150 m) of the ROAD WORK AHEAD, or similar, sign on an undivided highway due to non-recurring congestion, the contractor shall deploy a means of providing advance warning of the traffic congestion, as approved by the engineer. The warning location shall be no less than 1000 feet (300 m) and no more than 0.5 mile (0.8 km) in advance of the end of the traffic queue on divided

highways and no less than 500 feet (150 m) and no more than 0.5 mile (0.8 km) in advance of the end of the traffic queue on undivided highways.

3.0 Work Hour Restrictions.

3.1 There are three major summer holiday periods: Memorial Day, Independence Day, and Labor Day. All lanes shall be scheduled to be open to traffic during these holiday periods, from 12:00 noon on the last working day preceding the holiday until 9:00 a.m. on the first working day subsequent to the holiday.

B. PROJECT CONTACT FOR CONTRACTOR/BIDDER QUESTIONS

All questions concerning this project during the bidding process shall be forwarded to the project contact listed below:

*Name : Alonzo Washington
 Address: 211 N Broadway Suite 2800 St. Louis Mo 63102
 Phone Number: 314-206-4459
 Email Address : Alonzo.Washington@wsp.com*

C. EMERGENCY PROVISIONS AND INCIDENT MANAGEMENT JSP-90-11

1.0 The contractor shall have communication equipment on the construction site or immediate access to other communication systems to request assistance from the police or other emergency agencies for incident management. In case of traffic accidents or the need for police to direct or restore traffic flow through the job site, the contractor shall notify police or other emergency agencies immediately as needed. The area engineer's office shall also be notified when the contractor requests emergency assistance.

Alonzo Washington WSP at 314-206-4459 or 662-648-9348, Alonzo.Washington@wsp.com

2.0 In addition to the 911 emergency telephone number for ambulance, fire or police services, the following agencies may also be notified for accident or emergency situation within the project limits.

Missouri Highway Patrol Troop C (636-300-2800)		
City of Festus	City of Herculaneum	City of Pevely
(Fire: 636-937-7661	(Fire: 636-475-3080	(Fire: 636-475-7401
Police: 636-937-5184)	Police: 636-479-4791)	Police: 636-475-4498)

2.1 This list is not all inclusive. Notification of the need for wrecker or tow truck services will remain the responsibility of the appropriate police agency.

2.2 The contractor shall notify enforcement and emergency agencies before the start of construction to request their cooperation and to provide coordination of services when emergencies arise during the construction at the project site. When the contractor completes

this notification with enforcement and emergency agencies, a report shall be furnished to the engineer on the status of incident management.

3.0 No direct pay will be made to the contractor to recover the cost of the communication equipment, labor, materials or time required to fulfill the above provisions.

D. UTILITIES JSP-93-26C

1.0 For informational purposes only, the following is a list of names, addresses, and telephone numbers of the known utility companies in the area of the construction work for this improvement:

<u>Utility Name</u>	<u>Known Required Adjustment</u>
Crystal City Water Department 130 Mississippi Ave Crystal City, MO 63019 Telephone: 636-937-6415	No
Ameren Missouri 100 Big Hollow Road Festus, MO 63028 Telephone: 800-552-7583	No
Spire Energy 700 Market St St. Louis, MO 63101 Telephone: 800-887-4173	No

1.1 The existence and approximate location of utility facilities known to exist, as shown on the plans, are based upon the best information available to the Jefferson County Port Authority (JCPA) at this time. This information is provided by the JCPA "as-is" and the JCPA expressly disclaims any representation or warranty as to the completeness, accuracy, or suitability of the information for any use. Reliance upon this information is done at the risk and peril of the user, and the JCPA shall not be liable for any damages that may arise from any error in the information. It is, therefore, the responsibility of the contractor to verify the above listing information indicating existence, location and status of any facility. Such verification includes direct contact with the listed utilities.

1.2 The contractor agrees that any effects of the presence of the utilities, their relocation, contractor's coordination of work with the utilities and any delay in utility relocation shall not be compensable as a suspension of work, extra work, a change in the work, as a differing site condition or otherwise including but, without limitation, delay, impact, incidental or consequential damages. The contractor's sole remedy for the effects of the presence of

utilities, delay in their relocation or any other effects shall be an excusable delay as provided in Section 105.7.3. The contractor waives, for itself, its subcontractors and suppliers the compensability of the presence of utilities, delay in their relocation and any cost to the contractor, its subcontractors and suppliers in any claim or action arising out of or in relation to the work under the contract.

1.3 The contractor shall be solely responsible and liable for incidental and consequential damage to any utility facilities or interruption of the service caused by it or its subcontractors operation. The contractor shall hold and save harmless the Commission from damages to any utility facilities interruption of service by it or its subcontractor's operation.

2.0 It shall be noted by the contractor that MoDOT is a member of Missouri One Call (800 Dig Rite). Some work on this project may be in the vicinity of MoDOT utility facilities, which includes but is not limited to traffic signal cables, highway lighting circuits, ITS cables, cathodic protection cables, etc. Prior to beginning work, the contractor shall request locates from Missouri One Call. The contractor shall also complete the Notice of Intent to Perform Work form located at the Missouri Department of Transportation website:

<http://www.modot.mo.gov/asp/intentToWork.shtml>

The contractor shall submit the form over the web (preferred method) or by fax to the numbers on the printed form. The notice must be submitted a minimum of 2 and a maximum of 10 working days prior to excavation just as Missouri One Call requires.

E. TREE CLEARING RESTRICTION JSP-07-05

1.0 Description. The project is within the known breeding range of the federally endangered Indiana bat. To avoid possible impacts to roosting Indiana bats, no tree clearing will be allowed between **April 1st and October 31st**.

2.0 Basis of Payment. No direct pay shall be provided for any labor, equipment, time, or materials necessary to complete this work. The contractor shall have no claim, or basis for any claim or suit whatsoever, resulting from compliance with this provision.

F. ORDER OF WORK

The Scope of Work includes grading, removal of improvements, concrete pavement, guardrail, concrete curb ramp installation, and traffic control within the Jefferson County Port Authority Site and other incidental items.

G. AMERICANS WITH DISABILITIES ACT (ADA) COMPLIANCE AND FINAL ACCEPTANCE OF CONSTRUCTED FACILITIES JSP-10-01A

1.0 Description. The contractor shall comply with all laws pertaining to the Americans with Disabilities Act (ADA) during construction of pedestrian facilities on public rights of way for this project. An ADA Checklist is provided herein to be utilized by the contractor for verifying compliance with the

ADA law. The contractor is expected to familiarize himself with the plans involving pedestrian facilities and the ADA Post Construction Checklist prior to performing the work.

2.0 ADA Checklist. The contractor can locate the ADA Checklist form on the Missouri Department of Transportation website:

http://www.modot.mo.gov/business/contractor_resources/forms.htm

2.1 The ADA Checklist is intended to be a helpful tool for the contractor to use during the construction of the pedestrian facilities and a basis for the commission's acceptance of work. Prior to work being performed, the contractor shall bring to the engineer's attention any planned work that is in conflict with the design or with the requirement shown in the checklist. Situations may arise where the checklist may not fully address all requirements needed to construct a facility to the full requirements of current ADA law. In those situations, the contractor shall propose a solution to the engineer that is compliant with current ADA law using the following hierarchy of resources: 2010 ADA Standards for Accessible Design, Draft Public Rights of Way Accessibility Guidelines (PROWAG) dated November 23, 2005, MoDOT's Engineering Policy Guidelines (EPG), or a solution approved by the U.S. Access Board.

2.2 It is encouraged that the contractor monitor the completed sections of the newly constructed pedestrian facilities in attempts to minimize negative impacts that his equipment, subcontractors or general public may have on the work. Completed facilities must comply with the requirements of ADA and the ADA Checklist or have documented reasons for the non-complaint items to remain.

3.0 Coordination of Construction.

3.1 Prior to construction and/or closure on an existing pedestrian path of travel, the contractor shall submit a schedule of work to be constructed, which includes location of work performed, the duration of time the contractor expects to impact the facility and an accessible signed pedestrian detour complaint with MUTCD Section 6D that will be used during each stage of construction. This plan shall be submitted to the engineer for review and approval at or prior to the pre-construction conference. Accessible signed detours shall be in place prior to any work being performed that has the effect of closing an existing pedestrian travel way.

3.2 When consultant survey is included in the contract, the contractor shall use their survey crews to verify that the intended design can be constructed to the full requirements as established in the 2010 ADA Standards. When 2010 ADA Standards do not give sufficient information to construct the contract work, the contractor shall refer to the PROWAG.

3.3 When consultant survey is not included in the contract, the contractor shall coordinate with the engineer, prior to construction, to determine if additional survey will be required to confirm the designs constructability.

4.0 Final Acceptance of Work. The contractor shall provide the completed ADA Checklist to the engineer at the semi-final inspection. ADA improvements require final inspection and compliance with the ADA requirements and the ADA Checklist. Each item listed in the checklist must receive either a "YES" or an "N/A" score. Any item receiving a "NO" will be deemed non-compliant and shall be corrected at the contractor's expense unless deemed otherwise by the engineer. Documentation must be provided about the location of any non-complaint items that are allowed to remain at the end of the construction project. Specific details of the non-complaint items, the ADA requirement that the

work was not able to comply with, and the specific reasons that justify the exception are to be included with the completed ADA Checklist provided to the engineer.

4.1 Slope and grade measurements shall be made using a properly calibrated, 2 foot long, electronic digital level approved by the engineer.

5.0 Basis of Payment. The contractor will receive full pay of the contract unit cost for all sidewalk, ramp, curb ramp, median, island, approach work, cross walk striping, APS buttons, pedestrian heads, detectible warning systems and temporary traffic control measures that are completed during the current estimate period as approved by the engineer. Based upon completion of the ADA Checklist, the contractor shall complete any necessary adjustments to items deemed non-compliant as directed by the engineer.

5.1 No direct payment will be made to the contractor to recover the cost of equipment, labor, materials, or time required to fulfill the above provisions, unless specified elsewhere in the contract documents.

H. LIQUIDATED DAMAGES FOR WINTER MONTHS

1.0 Description. Revise Sec 108.8.1.2 (a) and (b) and substitute the following for the project:

- (a) Liquidated damages will be assessed from December 15 to March 15
- (b) Liquidated damages will be assessed for Saturdays, Sundays and Holidays.

I. DISADVANTAGED BUSINESS ENTERPRISE (DBE) PROGRAM REQUIREMENTS

1.0 Description: Insert the following additional program provisions in the Disadvantaged Business Enterprise (DBE) Program Requirements of the General Provisions and Supplemental Specifications to 2011 Missouri Standard Specifications for Highway Construction.

2.0 Factors Used to Determine if a DBE Regular Dealer of Liquid Asphalt is Performing a CUF. The DBE must be responsible with respect to materials and supplies used on a contract perform all of the following, pursuant to 49 CFR § 26.55(c)(1) and 7 CSR 10-8.131:

- (a) Negotiating price.
- (b) Determining quality and quantity.
- (c) Ordering the material.
- (d) Paying for the material itself.
- (e) 30% of the work must be performed by the DBE's permanent employees (which does not include owner-operators or leased employees) or those hired by the DBE firm for the project from an independent source other than the prime contractor, such as a union hall. For at least 30% of the work the DBE's owned (not leased) equipment shall be used and the DBE must provide documentation that this owned equipment was used on the project as required by this provision.
- (f) For up to 70% of the remaining work the equipment used by the DBE must be by long term

lease (at least one year) with another DBE or non-DBE but not the prime contractor. The DBE must have absolute priority over other businesses or entities to use the long term leased equipment and must display the name and identification number of the DBE.

(g) The Contractor shall require DBE subcontractors to provide documentation in one of the following formats: bills of lading, hauling tickets, shippers manifest, and/or paid invoices. Regardless of the document format, the document(s) shall include the following information: name of the carrier, full name of the driver, driver ID number(s), truck and tanker ID or VIN number, and reflect the contract number, job number, county and route

The contract number, job number, county and route can be reported through a consignee number or lift number, as long as the DBE Subcontractor has provided the consignee number, or lift number, along with project specific information which shall include contract number, job number, county and route.

The documentation must be submitted and generated by the DBE Subcontractor and be printed on letterhead or other similar documentation outlining the contact information for the DBE Subcontractor. In addition the documentation shall indicate the quantity and amount invoiced to the prime contractor (Such as an invoice). **“MoDOT’s DBE Contractor/Subcontractor Project Trucker and Equipment List”** (Form 1) will be provided by MoDOT and shall be completed and submitted to MoDOT by the DBE Subcontractor or Liquid Asphalt Supplier before Asphalt Operations begin. The DBE Subcontractor shall report all trucks and tankers they currently own and all full time drivers that they employ, including all of the drivers numbers for each terminal the drivers pick up from. In addition the DBE Subcontractor shall include a list of “long term” leased equipment, along with drivers and drivers’ numbers to the DBE Subcontractor Project Trucker and Equipment List. The DBE Subcontractor shall attach copies of all current long term lease agreements to the DBE Subcontractor Project Trucker and Equipment List.

(h) DBE Trucking/Hauling regulations do not apply to regular dealers of liquid asphalt.

3.0 When a DBE Regular Dealer of Liquid Asphalt is Not Eligible for DBE Credit.

(a) “If its role is limited to that of an extra participant in a transaction, contract or project through which funds are passed in order to obtain the appearance of DBE participation.” 49 CFR § 26.55(c)(2)

(b) If the type of transaction does not allow the DBE subcontractor to perform one of the four required functions, such as a prime contractor deciding the price of a commodity to be supplied by the DBE, that transaction is not eligible for DBE credit.

(c) Work that is performed with trucks that are not owned nor under a lease of at least one year by the DBE will not be eligible for DBE credit.

(d) A lack of documentation verifying that at least one DBE owned (not leased) tractor and tanker/ trailer was used to haul liquid asphalt on the project will result in no DBE credit given on that project.

4.0 This form will be completed by the inspector from the project office during the time of the project. MoDOT will use the *MoDOT DBE Job-Site Review CUF Determination*

Form to verify CUF was performed on the project, a copy of which is available on the MoDOT Contractor Resource website.

FEDERAL AID PROVISIONS

December 1980

NOTICE OF REQUIREMENT FOR AFFIRMATIVE ACTION TO ENSURE EQUAL EMPLOYMENT OPPORTUNITY (EXECUTIVE ORDER 11246)

1. The Offeror's or Bidders attention is called to the "Equal Opportunity Clause" and the Standard Federal Equal Employment Opportunity Construction Contract Specifications" set forth therein.
2. The goals and timetables for minority and female participation, expressed in percentage terms for the Contractor's aggregate workforce in each trade on all construction work in the covered area, are as follows:
3. Construction contractors which are participating in an approved Hometown Plan (see 41 CFR 60-4.5) are required to comply with the goals of the Hometown Plan with regard to construction work they perform in the area covered by the Hometown Plan. With regard to all their covered construction work, such contractors are required to comply with the following goals:

Goals for Female participation for each trade

AREA COVERED

Goals for women apply nationwide

GOALS AND TIMETABLES

Goals

Timetable	(Percent)
From April 1, 1978 until March 31, 1979	3.1
From April 1, 1979 until March 31, 1980	5.1
From April 1, 1980 until March 31, 1981	6.9

Goals for Minority Participation for Each Trade

<u>County</u>	<u>Goal (Percent)</u>	<u>County</u>	<u>Goal (Percent)</u>
Adair	4	Linn	4
Andrew	3.2	Livingston	10
Atchison	10	McDonald	2.3
Audrain	4	Macon	4
Barry	2.3	Madison	11.4
Barton	2.3	Maries	11.4
Bates	10	Marion	3.1
Benton	10	Mercer	10
Bollinger	11.4	Miller	4
Boone	6.3	Mississippi	11.4
Buchanan	3.2	Moniteau	4
Butler	11.4	Monroe	4
Caldwell	10	Montgomery	11.4
Callaway	4	Morgan	4
Camden	4	New Madrid	26.5
Cape Girardeau	11.4	Newton	2.3
Carroll	10	Nodaway	10

Carter	11.4	Oregon	2.3
Cass	12.7	Osage	4
Cedar	2.3	Ozark	2.3
Chariton	4	Pemiscot	26.5
Christian	2	Perry	11.4
Clark	3.4	Pettis	10
Clay	12.7	Phelps	11.4
Clinton	10	Pike	3.1
Cole	4	Platte	12.7
Cooper	4	Polk	2.3
Crawford	11.4	Pulaski	2.3
Dade	2.3	Putnam	4
Dallas	2.3	Ralls	3.1
Daviess	10	Randolph	4
DeKalb	10	Ray	12.7
Dent	11.4	Reynolds	11.4
Douglas	2.3	Ripley	11.4
Dunklin	26.5	St. Charles	14.7
Franklin	14.7	St. Clair	2.3
Gasconade	11.4	St. Francois	11.4
Gentry	10	Ste. Genevieve	11.4
Greene	2	St. Louis City	14.7
Grundy	10	St. Louis County	14.7
Harrison	10	Saline	10
Henry	10	Schuyler	4
Hickory	2.3	Scotland	4
Holt	10	Scott	11.4
Howard	4	Shannon	2.3
Howell	2.3	Shelby	4
Iron	11.4	Stoddard	11.4
Jackson	12.7	Stone	2.3
Jasper	2.3	Sullivan	4
Jefferson	14.7	Taney	2.3
Johnson	10	Texas	2.3
Knox	4	Vernon	2.3
Laclede	2.3	Warren	11.4
Lafayette	10	Washington	11.4
Lawrence	2.3	Wayne	11.4
Lewis	3.1	Webster	2.3
Lincoln	11.4	Worth	10
		Wright	2.3

These goals are applicable to all of the contractor's construction work (whether or not is Federal or federally assisted) performed in the covered area. If the contractor performs construction work in a geographical area located outside of the covered area, it shall apply the goals established for such geographical area where the work is actually performed. With regard to this second area, the contractor also is subject to the goals for both its federally involved and nonfederally involved construction.

The Contractor's compliance with the Executive Order and the regulations in 41 CFR Part 60-4 shall be based on Its Implementation of the Equal Opportunity Clause, specific affirmative action obligations required by the specifications set forth in 41 CFR 60-4.3(a), and its effort to meet the goals. The hours of minority and female employment and training must be substantially uniform throughout the length of the contract, and in each trade, and the Contractor shall make a good faith effort to employ minorities and women evenly on each of its projects. The transfer of minority, or female employees or trainees from Contractor to Contractor or from project to project

for the sole purpose of meeting the Contractor's goals shall be a violation of the contract, the Executive Order and the regulations in 41 CFR Part 60-4. Compliance with the goals will be measured against the total work hours performed.

4. The Contractor shall provide written notification to the Director of the Office of Federal Contract Compliance Programs within 10 working days of award of any construction subcontract in excess of \$10,000 at any tier for construction work under the contract resulting from this solicitation. The notification shall list the name, address and telephone number of the subcontractor; employer identification number; estimated dollar amount of the subcontract; estimated starting and completion dates of the subcontract; and the geographical area in which the subcontract is to be performed.
5. As used in this Notice, and in the contract resulting from this solicitation, the "covered area" of the county, route and limits described in the proposal for the work.

July 1986

STANDARD FEDERAL EQUAL EMPLOYMENT OPPORTUNITY CONSTRUCTION
CONTRACT SPECIFICATIONS (EXECUTIVE ORDER 11246)

1. As used in these specifications:
 - a. "Covered area" means the geographical area described in the solicitation which this contract resulted.
 - b. "Director" mean Director, Office of Federal Contract Compliance Programs, United States Department of labor, or any person to who the Director delegates authority;
 - c. "Employer Identification Number" means the Federal Social Security number used on the Employer's quarterly Federal Tax Return, U.S. Treasury Department Form 941;
 - d. "Minority" includes;
 - (i) Black (all persons having origins in any of the Black African racial groups not of Hispanic origin);
 - (ii) Hispanic (all persons of Mexican, Puerto Rican, Cuban, Central or South American or other Spanish Culture or origin, regardless of race);
 - (iii) Asian and pacific islander (all persons having origins in any of the original peoples of the Far East, southeast Asia, the Indian Subcontinent, or the Pacific Islands; and
 - (iv) American Indian or Alaskan Native (all persons having origins in any of the original peoples of North American and maintain identifiable affiliations through membership and participation or community identifications.
2. Whenever the Contractor, or any Subcontractor at any tier, subcontractors a portion of the work involving any construction trade, it shall physically include in each subcontract in excess of \$10,000 the provisions of these specifications and the Notice which contains the applicable goals for minority and female participation and which is set forth in the solicitations from which this contract resulted.
3. If the Contract is participating (pursuant to 41 CFR 60-4.5) in a Hometown Plan approved by the U.S. Department of Labor in the covered area either individually or through the association, its affirmative action obligations on all work in the Plan area (including goals and timetables) shall be in accordance with the Plan for those trades which have unions participating in the Plan. Contractors must be able to demonstrate their participation in and compliance with the provisions of any such Hometown Plan. Each Contractor or Subcontractor participating in an approved Plan is individually required to comply with its obligation under the EEO clause, and to make a good faith effort to achieve each goal under the Plan in each trade in which it has employees. The overall good faith

performance by other Contractors or Subcontractors toward a goal in an approved Plan does not excuse any covered Contractor's or Subcontractors' failure to take good faith efforts to achieve the Plan goals and timetables.

4. The Contractor shall implement the specific affirmative action standards provided in paragraphs 7a through 7p of these specifications. The goals set forth in the solicitation from which this contract resulted are expressed as percentages of the total hours of employment and training of minority and female utilization the Contractor should reasonably be able to achieve in each construction trade in which it has employees in the covered area. Covered Construction contractors performing construction work in geographical areas where they do not have a Federal or federally assisted construction contract shall apply the minority and female goals established for the geographical area where the work is being performed. Goals are published periodically in the Federal Register in notice form, and such notices may be obtained from any Office of Federal Contract Compliance Programs office or from Federal procurement contracting officers. The Contractor is expected to make substantially uniform progress toward its goals in each craft during the period specified.
5. Neither the provisions of any collective bargaining agreement, nor the failure by a union with who the Contractor has a collective bargaining agreement, to refer either minorities or women shall excuse the Contractor's obligations under these specifications, Executive Order 11246, or the regulations promulgated pursuant thereto.
6. In order for the nonworking training hours or apprentices and trainees to be counted in meeting the goal, such apprentices and trainees must be employed by the Contractor during the training period, and the Contractor must have made a commitment to employ the apprentices and trainees at the completion of their training, subject to the availability of employment opportunities. Trainees must be trained pursuant to training programs approved by the U.S. Department of Labor.
7. The contractor shall take specific affirmative actions to ensure equal employment opportunity. The evaluation of the Contractor's compliance with these specifications shall be used its effort to achieve maximum results from its actions. The Contractor shall document these efforts fully, and shall implement affirmative action steps at least as extensive as the following:
 - a. Ensure and maintain a working environment free of harassment, intimidation, and coercion at all sites, and all facilities at which the Contractor's employees are assigned to work. The Contractor shall specifically ensure that all foremen, superintendents, and other on-site supervisory personnel are aware of and carry out the Contractor's obligation to maintain such a working environment, with specific attention to minority or female individuals working at such sites or in such facilities.
 - b. Establish and maintain a current list of minority and female recruitment sources, provide written notification to minority and female recruitment sources and to community organizations when the Contractor or its unions have employment opportunities available, and maintain a record of the organizations' responses.
 - c. Maintain a current file of the names, addresses and telephone numbers of each minority and female off-the-street applicant and minority or female referral from a union, a recruitment source or community organization and what action was taken with respect to each such individual. If such individual was sent to the union hiring hall for referral and was not referred back to the Contractor by the union or, if referred not employed by the contractor, this shall be documented in the file with the reason therefore, along with whatever additional actions the Contractor may have taken.
 - d. Provide immediate written notification to the Director when the union or unions with which the Contractor has as collective bargaining agreement has not referred to the contractor a minority person or woman sent by the Contractor, or when the Contractor has other information that the union referral process has impeded the Contractor's efforts to meet its obligations.
 - e. Develop on-the-job training opportunities and/or participate in training programs for the area which expressly include minorities and women, including upgrading programs and apprenticeship and

trainee programs relevant of the contractor's employment needs, especially those programs funded or approved by the Department of Labor. The contractor shall provide notice of these programs to the sources complied under 7b above.

- f. Disseminate the Contractor's EEO policy by providing notice of the policy to unions and training programs and requesting their cooperation in assisting the Contractor in meeting its EEO obligations; by including it in any policy manual and collective bargaining agreement by publicizing it in the company newspaper, annual report, etc., by specific review of the policy with all management personnel and with all minority and female employees at least one a year; and by posting the company EEO policy on bulletin boards accessible to all employees at each location where construction work is performed.
- g. Review, at least annually, the company's EEO policy and affirmative action obligations under these specifications with all employees having any responsibility for hiring, assignment, layoff, termination or other employment decisions including specific review of these items with on-site supervisory personnel such as superintendents, General foreman, etc., prior to the initiation of construction work at any job site. A written record shall be made and maintained identifying the time and place of these meetings, person attending, subject matter discussed, and the disposition of the subject matter.
- h. Disseminate the Contractor's EEO policy externally by including it in any advertising in the news media, specifically including minority and female news media and providing written notification to and discussing the contractor's EEO policy with other Contractors and Subcontractors with who the Contractor does or anticipates doing business.
- i. Direct is a recruitment effort, both oral and written, to minority female and community organizations, to schools with minority and female students and to minority and female recruitment and training organizations serving the Contractor's recruitment area and employment needs. Not later than one month prior to the date for the acceptance or applicants for apprenticeship or other training by any recruitment source, the Contractor shall send written notification to organizations such as the above, describing the openings, screening procedures, and test to be used in the selection process.
- j. Encourage present minority and female employees to recruit other minority persons and women and, where reasonable, provide after school, summer vacations employment to minority and female youth both on the site and in other areas or contractor's workforce.
- k. Validate all tests and other selection requirements where there is an obligation to do so under 41 CFR Part 60-3.
- l. Conduct, at least annually, an inventory and evaluation at least of all minority and female personnel for promotional opportunities and encourage these employees to seek or to prepare for, through appropriate training, etc. such opportunities.
- m. Ensure that seniority practices, job classifications, work assignments and other personnel practices, do not have a discriminatory effect by continually monitoring all personnel and employment related activities to ensure that the EEO policy and the Contractor's obligation under these specifications are being carried out.
- n. Ensure that all facilities and company activities are non-segregated except that separate or single-user toilet and necessary changing facilities shall be provided to assure privacy between the sexes.
- o. Document and maintain a record of all solicitations or offers for subcontracts from minority and female construction contractors and suppliers, including circulation of solicitations to minority and female contractor associations and other business associations.

- p. Conduct a review, at least annually, of all supervisors' adherence to and performance under the Contractor's EEO policies and affirmative action obligations.
8. Contractors are encouraged to participate in voluntary associations which assist in fulfilling one or more of their affirmative action obligations (7a through 7p). The efforts of a contractor association, joint contractor union, contractor community, or other similar group of which the contractor is a member and participant, may be asserted as fulfilling anyone or more of its obligations under 7a through 7p of these specifications provided that the contractor actively participates in the group, makes every effort to assure that the group has a positive impact on the employment of minorities and women in the industry, ensures that the concrete benefits of the program are reflected in the contractor's minority and female workforce participation, makes a good faith effort to meet its individual goals and timetables, and can provide access to documentation which demonstrates the effectiveness of actions taken on behalf of the contractor. The obligation to comply, however, is the Contractor's and failure of such a group to fulfill an obligation shall not be a defense for the Contractor's noncompliance.
9. A single goal for minorities and a separate single goal for women have been established to provide equal employment opportunity and to take affirmative action for all minority groups, both male and female, and all women, both minority and non-minority. Consequently, the group is employed in a substantially disparate manner (for example, even though the Contractor has achieved its goals for women generally, the Contractor may be in violation of the executive order if a specific minority group of women is underutilized).
10. The Contractor shall not use the goals and timetables or affirmative action standards to discriminate against any person because of race, color, religion, sex, or national origin.
11. The Contractor shall not enter into any Subcontract with any person or firm debarred from Government contract pursuant to Executive Order 11246.
12. The Contractor shall carry out such sanctions and penalties for violation of these specifications and of the Equal Opportunity Clause, including suspension, termination and cancellation of existing subcontracts as may be imposed or ordered pursuant to Executive Order 11246, as amended, and its implementing regulations, by the Office of Federal Contract Compliance Programs. Any Contractor who fails to carry out such sanctions and penalties shall be in violation of these specifications and Executive Order 11246, as amended.
13. The Contractor, in fulfilling its obligations under these specifications, shall implement specific affirmative action steps, at least as extensive as those standards prescribed in paragraph 7 of these specifications, so as to achieve maximum results from its efforts to ensure equal employment opportunity. If the Contractor fails to comply with the requirements of the Executive Order, the implementing regulations, or these specifications, the Direct shall proceed in accordance with 41 CFR 60-4.8.
14. The Contractor shall designate a responsible official to monitor all employment related activity to ensure that the company EEO policy is being carried out to submit reports relating to the provisions hereof as may be required by the Government and to keep records. Records shall at least include for each employee the name, address, telephone numbers, construction trade, union affiliation if any, employee identification number when assigned, social security number, race, sex, status, (e.g. mechanic, apprentice, trainee, helper, or laborer), dates of changes in status, hours worked per week in the indicated trade, rate of pay, and locations at which the work was performed. Records shall be maintained in an easily understandable and retrievable form; however, to the degree that existing records satisfy this requirement, contractors shall not be required to maintain separate records.
15. Nothing herein provided shall be constructed as a limitation upon the application of other laws which establish different standard of compliance or upon the application of requirements for the hiring of local or other area residents (e.g. those under the Public Works Employment Action of 1977 and the Community Development Block Grant Program).

OPERATING POLICY STATEMENT

The contractor shall accept as his operating policy the following statement, or one of equal coverage, which is designed to further the provision of equal employment opportunity to all persons without regard to their race, color, religion, sex, or national origin, and to promote the full realization of equal employment opportunity through a positive continuing program.

“It is the policy of this company to assure that applicants are employed, and that employees are treated during employment without regard to their race, religion, sex, color, or national origin. Such action shall include: employment, upgrading, demotion, or transfer, recruitment or recruitment advertising; layoff or termination; rates of pay or other forms of compensation; and selection for training, including apprenticeship, pre-apprenticeship, and/or on-the-job training.”

SUPPLEMENTAL REPORTING REQUIREMENTS

- A. The Contractor will keep such records as are necessary to determine compliance with the contractor’s equal employment opportunity obligations. The records kept by the contractor will be designed to indicate the number of minority and non-minority group members and women employed in each work classification on the project.
- B. All such records must be retained for a period of three years following completion of the contract work and shall be available at reasonable times and places for inspection by authorized representatives of the State Highway Agency and the Federal Highway Administration.
- C. The contractor and each covered subcontractor will submit to the State Highway Agency, for the month of July, for the duration of the project, a report (Form PR-1391) “Federal-Aid Highway Construction Contractors Annual EEO Report”, indicating the number of minority, women and non-minority group employees currently engaged in each work classification required by the contract work.

NONDISCRIMINATION IN EMPLOYMENT

July 1990

The following provisions are added by the State to the Required Contract Provisions of Federal-Aid Contracts.

The contractor is advised that the exemptions referred to in the Required Contract Provisions, Federal-Aid contracts under Section II, Nondiscrimination, Paragraph 3g, with respect to contracts and subcontracts, are substantial and are to be found in Chapter 60, Office of Federal Contract Compliance, Equal Employment Opportunity, Department of Labor (33 Federal Register 7804-7812, May 28, 1968, effective July 1, 1968, Chapter 60, Title 41, Code of Federal Regulations), by which contracts and subcontracts of \$10,000 or less and certain contracts and subcontracts for indefinite quantities are exempt.

The two pertinent exemption clauses are as follows:

60-1.5 Exemptions

- (a) General – (1) Transactions of \$10,000 or under. Contracts and Subcontractors not exceeding \$10,000, other than Government bills of lading, and other than contract and subcontracts with depositories of Federal funds in any amount and with financial institutions which are issuing and paying agents for U.S. savings bonds and savings notes, are exempt from the requirements of the equal opportunity clause. In determining the applicability of this exemption to any federally assisted construction contract, or subcontract thereunder, the amount of such contract or subcontract rather than the amount of the Federal financial assistance shall govern. No agency, contractor, or subcontractor shall procure supplies or services in a manner so as to avoid applicability of the equal opportunity clause: Provided, that where a contractor has contracts or subcontracts with the Government in any 12-month period which have an aggregate total value (or can reasonably be expected to have an aggregate total value) exceeding \$10,000,

the \$10,000 or under exemption does not apply, and the contracts are subject to the order and the regulation issued pursuant thereto regardless of whether any single contracts exceeds \$10,000.

Missouri

Division of Labor Standards

WAGE AND HOUR SECTION



MICHAEL L. PARSON, Governor

Annual Wage Order No. 31

Section 050
JEFFERSON COUNTY

In accordance with Section 290.262 RSMo 2000, within thirty (30) days after a certified copy of this Annual Wage Order has been filed with the Secretary of State as indicated below, any person who may be affected by this Annual Wage Order may object by filing an objection in triplicate with the Labor and Industrial Relations Commission, P.O. Box 599, Jefferson City, MO 65102-0599. Such objections must set forth in writing the specific grounds of objection. Each objection shall certify that a copy has been furnished to the Division of Labor Standards, P.O. Box 449, Jefferson City, MO 65102-0449 pursuant to 8 CSR 20-5.010(1). A certified copy of the Annual Wage Order has been filed with the Secretary of State of Missouri.

Original Signed by _____

Todd Smith, Director
Division of Labor Standards

Filed With Secretary of State: _____ **March 8, 2024**

Last Date Objections May Be Filed: **April 8, 2024**

Prepared by Missouri Department of Labor and Industrial Relations

OCCUPATIONAL TITLE	**Prevailing Hourly Rate
Asbestos Worker	\$69.00
Boilermaker	\$27.78*
Bricklayer-Stone Mason	\$63.68
Carpenter	\$62.94
Lather	
Linoleum Layer	
Millwright	
Pile Driver	
Cement Mason	\$57.23
Plasterer	
Communication Technician	\$27.78*
Electrician (Inside Wireman)	\$77.93
Electrician Outside Lineman	\$27.78*
Lineman Operator	
Lineman - Tree Trimmer	
Groundman	
Groundman - Tree Trimmer	
Elevator Constructor	\$27.78*
Glazier	\$27.78*
Ironworker	\$70.79
Laborer	\$53.19
General Laborer	
First Semi-Skilled	
Second Semi-Skilled	
Mason	\$57.18
Marble Mason	
Marble Finisher	
Terrazzo Worker	
Terrazzo Finisher	
Tile Setter	
Tile Finisher	
Operating Engineer	\$68.93
Group I	
Group II	
Group III	
Group III-A	
Group IV	
Group V	
Painter	\$54.90
Plumber	\$78.02
Pipe Fitter	
Roofer	\$57.42
Sheet Metal Worker	\$74.53
Sprinkler Fitter	\$76.64
Truck Driver	\$27.78*
Truck Control Service Driver	
Group I	
Group II	
Group III	
Group IV	

*The Division of Labor Standards received fewer than 1,000 reportable hours for this occupational title. The public works contracting minimum wage is established for this occupational title using data provided by Missouri Economic Research and Information Center.

**The Prevailing Hourly Rate includes any applicable fringe benefit amounts for each occupational title as defined in RSMo Section 290.210.

Heavy Construction Rates for
JEFFERSON County

Section 050

OCCUPATIONAL TITLE	**Prevailing Hourly Rate
Carpenter	\$63.92
Millwright	
Pile Driver	
Electrician (Outside Lineman)	\$76.16
Lineman Operator	
Lineman - Tree Trimmer	
Groundman	
Groundman - Tree Trimmer	
Laborer	\$52.34
General Laborer	
Skilled Laborer	
Operating Engineer	\$67.95
Group I	
Group II	
Group III	
Group IV	
Truck Driver	\$27.78*
Truck Control Service Driver	
Group I	
Group II	
Group III	
Group IV	

Use Heavy Construction Rates on Highway and Heavy construction in accordance with the classifications of construction work established in 8 CSR 30-3.040(3).

Use Building Construction Rates on Building construction in accordance with the classifications of construction work established in 8 CSR 30-3.040(2).

If a worker is performing work on a heavy construction project within an occupational title that is not listed on the Heavy Construction Rate Sheet, use the rate for that occupational title as shown on the Building Construction Rate Sheet.

*The Division of Labor Standards received fewer than 1,000 reportable hours for this occupational title. Public works contracting minimum wage is established for this occupational title using data provided by Missouri Economic Research and Information Center.

**The Prevailing Hourly Rate includes any applicable fringe benefit amounts for each occupational title.

OVERTIME and HOLIDAYS

OVERTIME

For all work performed on a Sunday or a holiday, not less than twice (2x) the prevailing hourly rate of wages for work of a similar character in the locality in which the work is performed or the public works contracting minimum wage, whichever is applicable, shall be paid to all workers employed by or on behalf of any public body engaged in the construction of public works, exclusive of maintenance work.

For all overtime work performed, not less than one and one-half (1½) the prevailing hourly rate of wages for work of a similar character in the locality in which the work is performed or the public works contracting minimum wage, whichever is applicable, shall be paid to all workers employed by or on behalf of any public body engaged in the construction of public works, exclusive of maintenance work or contractual obligation. For purposes of this subdivision, "**overtime work**" shall include work that exceeds ten hours in one day and work in excess of forty hours in one calendar week; and

A thirty-minute lunch period on each calendar day shall be allowed for each worker on a public works project, provided that such time shall not be considered as time worked.

HOLIDAYS

January first;
The last Monday in May;
July fourth;
The first Monday in September;
November eleventh;
The fourth Thursday in November; and
December twenty-fifth;

If any holiday falls on a Sunday, the following Monday shall be considered a holiday.

ADA CHECKLIST

Revised July 8, 2024

Job No. _____ Route _____ County _____ Location _____

Pedestrian Access Route (PROWAG R204)				
Figures/Examples	Requirements ¹	YES	NO	NA
<p>Sidewalk Width</p> 	<ul style="list-style-type: none"> • The minimum continuous and unobstructed clear width of a pedestrian access route shall be 4.0 feet, exclusive of the width of the curb. • The continuous clear width of pedestrian access routes for medians and pedestrian refuge islands must be 5 feet minimum in order to allow for passing space. • MoDOT Sidewalks shall be 5 feet wide minimum. ² • MoDOT Sidewalks located within 2 feet of the back of curb are to be constructed 6 feet wide minimum and constructed adjacent to the back of the curb. ² • Exception: an unaltered, existing sidewalk shall be 3 feet wide minimum and shall provide 5 foot x 5 foot passing spaces at intervals of 200 feet maximum. ² • Detectable warning surfaces shall be provided, where a curb ramp, landing, or blended transition connects to a street. Where commercial driveways are provided with traffic control devices or otherwise are permitted to operate like public streets, detectable warnings should be provided at the junction between the pedestrian route and the street. • Gratings, access covers, and other appurtenances shall not be located on curb ramps, landings, blended transitions, and gutters within the pedestrian access route. • Grade breaks shall not be permitted on the surface of curb ramps, blended transitions, landings, and gutter areas within the pedestrian access route. Surface slopes that meet at grade breaks shall be flush. 			
<p>Passing Spaces</p>	<ul style="list-style-type: none"> • Walkways in pedestrian access routes that are less than 5 feet in clear width shall provide passing spaces at intervals of 200 feet maximum. • Pedestrian access routes at passing spaces shall be 5 feet wide for a distance of 5 feet. 			
<p>Sidewalk Running Slope The grade that is parallel to the direction of travel, expressed as a ratio of rise to run or as a percent.</p>	<ul style="list-style-type: none"> • The running slope of a pedestrian access route shall be 5 percent maximum. • <u>Roadway Grade Exception:</u> Where pedestrian access routes are contained within a street or highway right-of-way, the grade of the pedestrian access route is permitted to equal the general grade established for the adjacent street or highway. • Running Slopes shall be measured using a calibrated 2 foot long digital level. 			

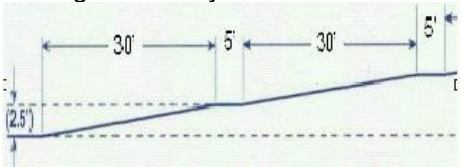
Figures/Examples	Requirements ¹	YES	NO	NA
<p>Sidewalk Cross Slope The grade that is perpendicular to the direction of accessible pedestrian travel, measured perpendicular to the curb line or edge of the street or highway, or measured perpendicular to the running grade.</p>	<ul style="list-style-type: none"> • The cross slope of the walkway of a pedestrian access route shall be 2 percent maximum. (Roadway Grade Exception may be considered) • 2010 ADA/ABA allows for cross slopes of up to ¼ inch per foot (2.08 percent). • In either case, a cross slope measurement of 2.1 percent or greater is not ADA compliant. • Cross Slopes shall be measured using a calibrated 2 foot long digital level. 			
<p>Sidewalk Ramps</p> <p>For example, a sidewalk ramp segment with the maximum allowed running slope of 8.33% would require a landing after every 30' of run.</p>  <p>The diagram illustrates a sidewalk ramp segment. It starts with a 30-foot run that rises 2.5 inches. This is followed by a 5-foot landing. The second 30-foot run also rises 2.5 inches, ending with another 5-foot landing. The total length of the segment is 70 feet.</p>	<ul style="list-style-type: none"> • A sidewalk segment (not contained within a street or highway border) with a running grade in excess of 5 percent but less than 8.33 percent is by definition a sidewalk ramp. • Sidewalk Ramps shall have landings at the top and the bottom of each ramp run. <ul style="list-style-type: none"> - The landing clear width shall be at least as wide as the widest ramp run leading to the landing. - The landing clear length shall be 5.0 feet long minimum. - Sidewalk Ramps that change direction between runs at landings shall have a clear landing 5.0 feet minimum by 5.0 feet minimum. - Landing slopes shall be 2 percent maximum. - Changes in level at grade breaks shall be flush. • Cross slope of ramp runs shall be 2 percent maximum. • The rise for any ramp run shall be 30 inches maximum. • Sidewalk Ramp runs with a rise greater than 6 inches shall have handrails. • Handrails shall be provided on both sides of stairs and sidewalk ramps. • Edge protection shall be provided on each side of sidewalk ramp runs. • Detectable warning surfaces shall be provided, where a curb ramp, landing, or blended transition connects to a street. • Gratings, access covers, and other appurtenances shall not be located on ramps, landings, blended transitions, and gutters within the pedestrian access route. • Grade breaks shall not be permitted on the surface of ramps, blended transitions, landings, and gutter areas within the pedestrian access route. Surface slopes that meet at grade breaks shall be flush. 			

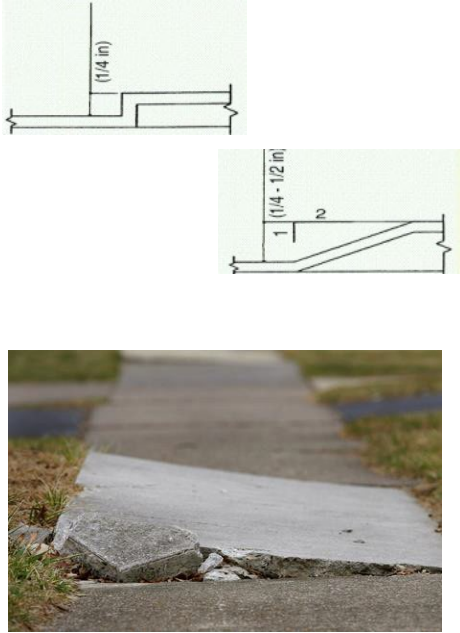
Figures/Examples	Requirements ¹	YES	NO	NA
<p data-bbox="92 136 352 168">Vertical Alignment</p>	<ul data-bbox="583 136 1709 574" style="list-style-type: none"> • Vertical alignment shall be planar within curb ramp runs, blended transitions, landings, and gutter areas within the pedestrian access route, and within clear spaces required for accessible pedestrian signals, street furniture, and operable parts. • Grade breaks shall not be permitted on the surface of curb ramps, blended transitions, landings, and gutter areas within the pedestrian access route. • Grade breaks shall be flush. • Running Slopes and Cross Slopes shall be measured using a calibrated 2 foot long digital level. • Where the pedestrian access route crosses rail tracks at grade, the surface of the pedestrian access route shall be level and flush with the top of the rail at the outer edges of the rail. The surface between the rails shall be aligned with the top of the rail. 			
<p data-bbox="92 586 340 618">Changes in Level</p> 	<ul data-bbox="583 586 1717 824" style="list-style-type: none"> • Changes in level at grade breaks shall be flush. • Changes in level of ¼ inch high maximum shall be permitted to be vertical. • Changes in level between ¼ inch high maximum and ½ inch high maximum shall be beveled with a slope not steeper than 1v:2h. • The bevel shall be applied across the entire level change. • Changes in level greater than ½ inch high shall be ramp grade or flatter, a slope of 8.33 percent or less. 			

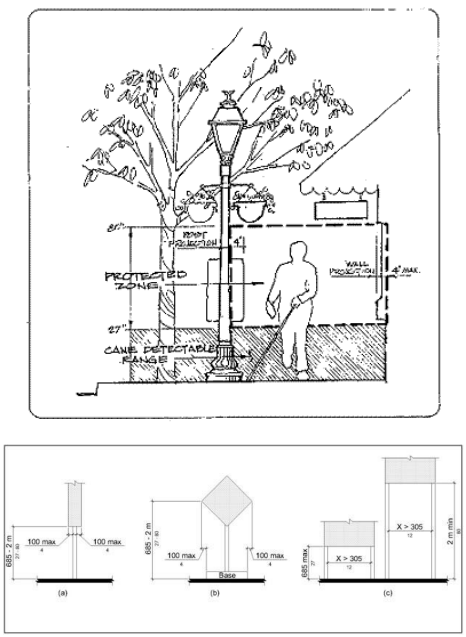
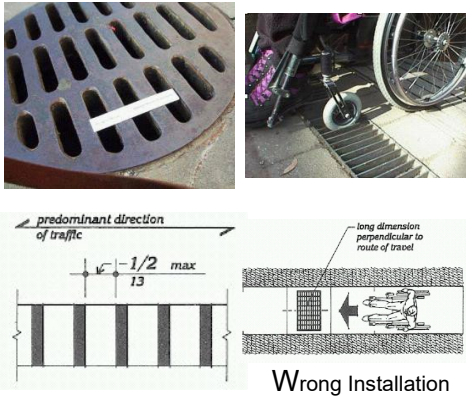
Figures/Examples	Requirements ¹	YES	NO	NA
	<ul style="list-style-type: none"> • Protruding objects on sidewalks and other pedestrian circulation paths shall not reduce the clear width required for pedestrian accessible routes. • Objects with leading edges more than 27 inches and not more than 80 inches above the finish floor or ground shall protrude 4 inches maximum horizontally into the circulation path. • Free-standing objects mounted on posts or pylons shall overhang circulation paths 4 inches maximum measured horizontally from the post or pylon base when located 27 inches minimum and 80 inches maximum above the finish floor or ground. The base dimension shall be 2.5 inches thick minimum. (2011 PROWAG R402.3) • Where a sign or other obstruction is mounted between posts or pylons and the clear distance between the posts or pylons is greater than 12 inches, the lowest edge of such sign or obstruction shall be 27 inches maximum or 80 inches minimum above the finish floor or ground. • Vertical clearance shall be 80 inches high minimum. Guardrails or other barriers shall be provided where the vertical clearance is less than 80 inches high. The leading edge of such guardrail or barrier shall be located 27 inches maximum above the finish floor or ground. • Guardrails or other barriers shall be provided where the vertical clearance is less than 80 inches high. The leading edge of such guardrail or barrier shall be located 27 inches maximum above the finish surface or ground. 			
 <p>Wrong Installation</p>	<ul style="list-style-type: none"> • Openings in floor and ground surfaces shall not allow passage of a sphere more than 1/2 inch diameter. Elongated openings shall be placed so that the long dimension is perpendicular to the dominant direction of travel. • Gratings, access covers, and other appurtenances shall not be located on curb ramps, landings, blended transitions, and gutters within the pedestrian access route. • Lift holes for manhole/utility covers shall not have an opening greater than 1/2 inch. Plugging of holes greater than 1/2 inch with a material approved by the engineer is acceptable as long as it complies with the changes in level requirements. 			

ENTRANCES (PROWAG R301)

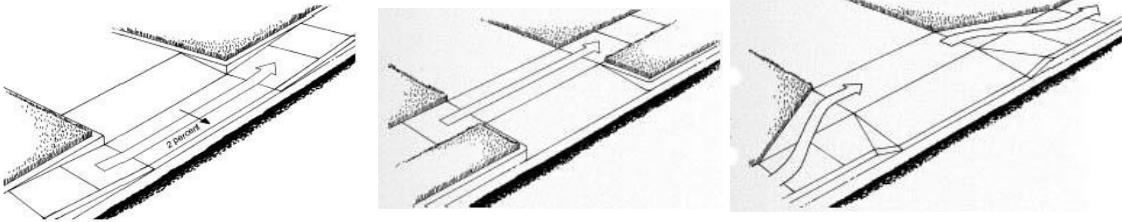
Figures/Examples	Requirements ¹	YES	NO	NA
	<ul style="list-style-type: none"> The minimum continuous and unobstructed clear width of a pedestrian access route provided across commercial and residential entrances shall be 4 feet minimum. Cross slope shall be 2 percent maximum. Be cautious with the transition from the driveway to the roadway to avoid grade combinations that will cause vehicles to bottom out when driving over the transition. ² 			

EDGE PROTECTION (PROWAG R406.8)

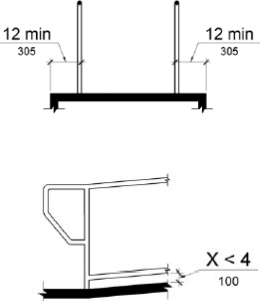
Figures/Examples	Requirements ¹	YES	NO	NA
	<ul style="list-style-type: none"> Edge protection shall be provided on each side of ramp runs and at each side of ramp landings. A curb or barrier shall be provided that prevents the passage of a 4 inch diameter sphere, where any portion of the sphere is within 4 inches of the finish floor or ground surface. Edge-protection shall not be required when the floor or ground surface of the ramp run or landing extends 12 inches minimum beyond the inside face of a handrail. Edge protection shall not be required on curb ramps and their landings. Edge protection shall not be required on ramps that are not required to have handrails and have flares not steeper than 1:10. Edge protection shall not be required on the sides of ramp landings having a vertical drop-off of 1/2 inch maximum within 10 inches horizontally of the minimum landing area. 			

HANDRAIL AND PEDESTRIAN GUARDRAIL (PROWAG R408)

Figures/Examples	Requirements ¹	YES	NO	NA
	<ul style="list-style-type: none"> • The clear width of walking surfaces shall be 4.0 feet minimum. • Handrails are required on ramp runs with a rise greater than 6 inches and on certain stairways. Handrails are not required on walking surfaces with running slopes less than 1:20. Where required, handrails shall be provided on both sides of stairs and ramps. • Handrails shall be continuous within the full length of each stair flight or ramp run. Inside handrails on switchback or dogleg stairs and ramps shall be continuous between flights or runs. • Top of gripping surfaces of handrails shall be 34 inches minimum and 38 inches maximum vertically above walking surfaces, stair nosings, and ramp surfaces. Handrails shall be at a consistent height above walking surfaces, stair nosings, and ramp surfaces. • Clearance between handrail gripping surfaces and adjacent surfaces shall be 1 1/2 inches minimum. • Handrail gripping surfaces with a circular cross section shall have an outside diameter of 1 1/4 inches minimum and 2 inches maximum. • Handrail gripping surfaces with a non-circular cross section shall have a perimeter dimension of 4 inches minimum and 6 1/4 inches maximum, and a cross-section dimension of 2 1/4 inches maximum. • Handrail gripping surfaces and any surfaces adjacent to them shall be free of sharp or abrasive elements and shall have rounded edges. • Handrails shall not rotate within their fittings. • Ramp handrails shall extend horizontally above the landing for 12 inches minimum beyond the top and bottom of ramp runs. Extensions shall return to a wall, guard, or the landing surface, or shall be continuous to the handrail of an adjacent ramp run. • At the top of a stair flight, handrails shall extend horizontally above the landing for 12 inches minimum beginning directly above the first riser nosing. Extensions shall return to a wall, guard, or the landing surface, or shall be continuous to the handrail of an adjacent stair flight. • At the bottom of a stair flight, handrails shall extend at the slope of the stair flight for a horizontal distance at least equal to one tread depth beyond the last riser nosing. Extension shall return to a wall, guard, or the landing surface, or shall be continuous to the handrail of an adjacent stair flight. • See Edge Protection section above (also PROWAG 406.8) for additional details. 			

STAIRWAYS (PROWAG R407)

Figures/Examples	Requirements ¹	YES	NO	NA
	<ul style="list-style-type: none"> All steps on a flight of stairs shall have uniform riser heights and uniform tread depths. Risers shall be 4 inches high minimum and 7 inches high maximum. Treads shall be 11 inches deep minimum. Open risers are not permitted. The radius of curvature at the leading edge of the tread shall be 1/2 inch maximum. Nosings that project beyond risers shall have the underside of the leading edge curved or beveled. Risers shall be permitted to slope under the tread at an angle of 30 degrees maximum from vertical. The permitted projection of the nosing shall extend 1 1/2 inches maximum over the tread below. Stairs shall have handrails complying with PROWAG 2005 R408. 			

UNOBSTRUCTED REACH RANGES (PROWAG R406)

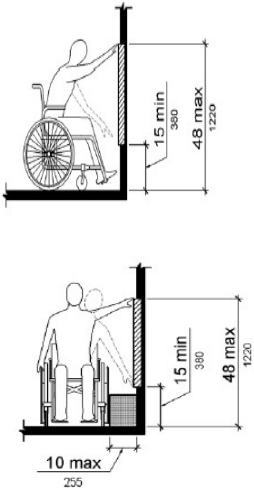
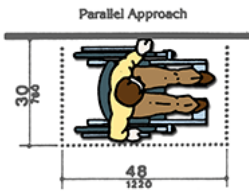
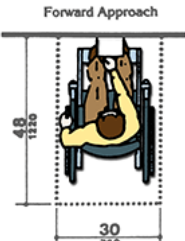
Figures/Examples	Requirements ¹	YES	NO	NA
	<p>Forward Reach</p> <ul style="list-style-type: none"> Where a forward reach is unobstructed, the high forward reach shall be 48 inches maximum and the low forward reach shall be 15 inches minimum above the finish floor or ground. <p>Side Reach</p> <ul style="list-style-type: none"> Where a clear floor or ground space allows a parallel approach to an element and the side reach is unobstructed, the high side reach shall be 48 inches maximum and the low side reach shall be 15 inches minimum above the finish floor or ground. EXCEPTION: An obstruction shall be permitted between the clear floor or ground space and the element where the depth of the obstruction is 10 inches maximum. (2011 PROWAG R406.3) <div style="display: flex; justify-content: space-around; align-items: center;"> <div style="text-align: center;"> <p>Parallel Approach</p>  </div> <div style="text-align: center;"> <p>Forward Approach</p>  </div> </div>			

CURB RAMPS (PROWAG R304)

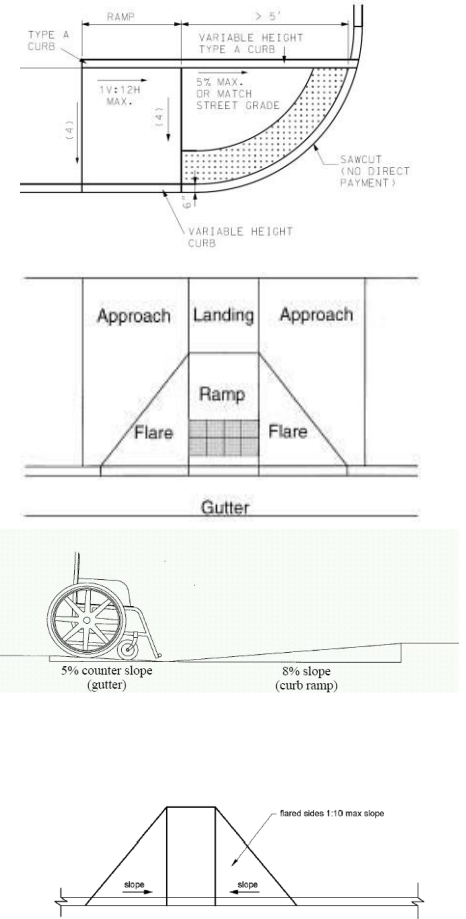
Figures/Examples	Requirements ¹	YES	NO	NA
<p>A curb ramp, blended transition, or a combination of curb ramps and blended transitions shall connect the pedestrian access routes at each pedestrian street crossing.</p>  <p>15 Foot Rule: For a compliant curb ramp to exceed 8.33 percent running grade, its constructed length must exceed 15.0 feet.</p>	<ul style="list-style-type: none"> The clear width of curb ramps, excluding the flares, shall be 4.0 feet minimum. Curb Ramp runs shall have a running slope between 5 percent minimum and 8.33 percent maximum but shall not require the curb ramp length to exceed 15.0 feet. <p>Exception: 15 Foot Rule: The running slope for a curb ramp is not limited to 8.33 percent maximum if the constructed curb ramp length exceeds 15 feet in length.</p> <ul style="list-style-type: none"> Cross slope of ramp runs shall be 2 percent maximum. (Roadway Grade Exception may be considered) The cross slope at midblock crossings shall be permitted to be warped to meet street or highway grade. Handrails and Edge protection shall not be required on curb ramps and their landings. Curb height = 0 inches within curb ramp spaces. Curb ramps must be flush with street. The counter slope of the gutter or street at the foot of a curb ramp, landing, or blended transition shall be 5 percent maximum. (R303.3.5) The adjacent surfaces at transitions at curb ramps to walks, gutters, and streets shall be at the same level. Flared sides with a slope of 10 percent maximum, measured parallel to the curbline, shall be provided where a pedestrian circulation path crosses the curb ramp. <ul style="list-style-type: none"> In alterations, where there is no landing at the top of curb ramps, curb ramp flares shall be provided and shall not be steeper than 1:12. Detectable warning surfaces shall be provided, where a curb ramp, landing, or blended transition connects to a street. Gratings, access covers, and other appurtenances shall not be located on curb ramps, landings, blended transitions, and gutters within the pedestrian access route. Grade breaks shall not be permitted on the surface of curb ramps, blended transitions, landings, and gutter areas within the pedestrian access route. Surface slopes that meet at grade breaks shall be flush. Grade Breaks at the top and bottom of curb ramp runs shall be perpendicular to the direction of the ramp run. 			

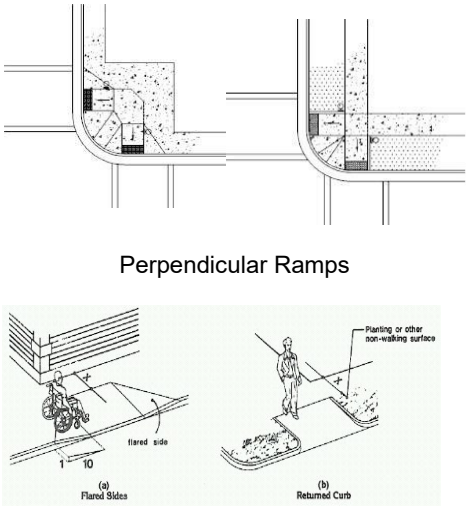
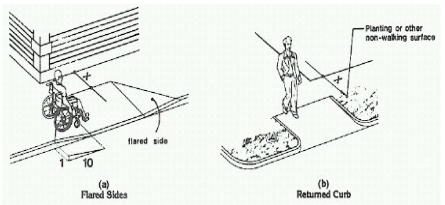
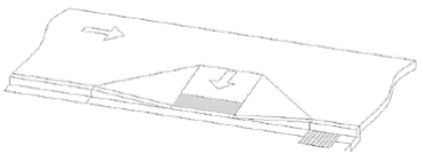
Figures/Examples	Requirements ¹	YES	NO	NA
 <p style="text-align: center;">Perpendicular Ramps</p>  <p>X = 4' Min. Flared Sides in Pathway Flared Sides Not in Pathway</p> <p><u>Roadway Grade Exception:</u> Where curb ramps, landings and blended transitions are contained within a street or highway right-of-way, the grade of the pedestrian access route is permitted to be modified to equal the general grade established for the adjacent street or highway.</p> 	<ul style="list-style-type: none"> • Perpendicular curb ramps shall have a running slope that cuts through or is built up to the curb at right angles or meets the gutter grade break at right angles. • The clear width of landings, blended transitions, and curb ramps, excluding flares, shall be 4.0 feet minimum. • The running slope shall be 5 percent minimum and 8.33 percent maximum but shall not require the ramp length to exceed 15.0 feet. • The cross slope at intersections shall be 2 percent maximum. (Roadway Grade Exception may be considered) • The cross slope at midblock crossings shall be permitted to be warped to meet street or highway grade. <p><u>Roadway Grade Exception:</u> The grade of pedestrian access routes within sidewalks is permitted to equal the general grade established for the adjacent street or highway. The cross slope of curb ramps, blended transitions, landings, and turning spaces at pedestrian street crossings without yield or stop control where vehicles can proceed through the intersection without slowing or stopping, and at midblock pedestrian street crossings are permitted to equal the street or highway grade.</p> <ul style="list-style-type: none"> • A landing 4.0 feet minimum by 4.0 feet minimum shall be provided at the top of the curb ramp and shall be permitted to overlap other landings and clear space. • Flared sides with a slope of 10 percent maximum, measured parallel to the curbline, shall be provided where a pedestrian circulation path crosses the curb ramp. • If the flared sides are not in the pathway (grass next to ramp), then there is no maximum slope and can be vertical curbs. (See adjacent figure for further explanation.) • Detectable warning surfaces shall be provided, where a curb ramp, landing, or blended transition connects to a street. • Gratings, access covers, and other appurtenances shall not be located on curb ramps, landings, blended transitions, and gutters within the pedestrian access route. • Grade breaks at the top and bottom of perpendicular curb ramps shall be perpendicular to the direction of ramp run. At least one end of the bottom grade break shall be at the back of curb. • Grade breaks shall not be permitted on the surface of curb ramps, blended transitions, landings, and gutter areas within the pedestrian access route. Surface slopes that meet at grade breaks shall be flush. • Where both ends of the bottom grade break are 5.0 feet or less from the back of curb, the detectable warning shall be located on the ramp surface at the bottom grade break. Where either end of the bottom grade break is more than 5.0 feet from the back of curb, the detectable warning shall be located on the lower landing. 			

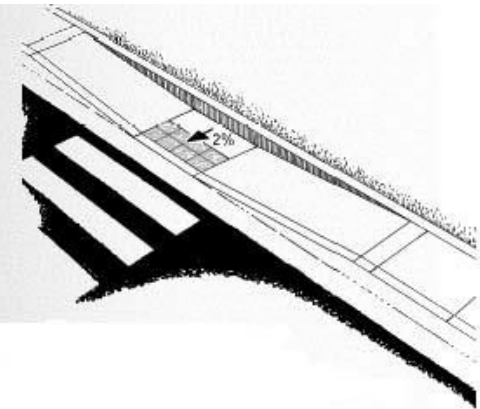
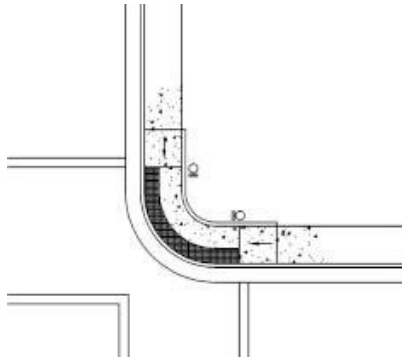

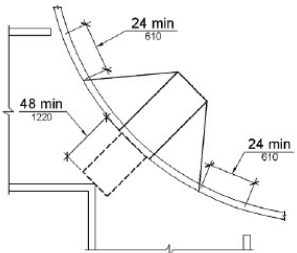

Figures/Examples	Requirements ¹	YES	NO	NA
 <p data-bbox="86 625 562 803">Curb Ramps and landings that are contained within a street or highway border may use the Roadway Grade Exception for slopes or cross slopes in the direction of the roadway travel being matched.</p>	<ul data-bbox="583 138 1747 414" style="list-style-type: none"> • Parallel curb ramps shall have a running slope that is in-line with the direction of sidewalk travel. • The clear width of landings, blended transitions, and curb ramps, excluding flares, shall be 4.0 feet minimum. • The running slope shall be 5 percent minimum and 8.33 percent maximum but shall not require the ramp length to exceed 15.0 feet. • The cross slope shall be 2 percent maximum. (Roadway Grade Exception may be considered) <p data-bbox="632 435 1747 641"><u>Roadway Grade Exception:</u> The grade of pedestrian access routes within sidewalks is permitted to equal the general grade established for the adjacent street or highway. The cross slope of curb ramps, blended transitions, landings, and turning spaces at pedestrian street crossings without yield or stop control where vehicles can proceed through the intersection without slowing or stopping, and at midblock pedestrian street crossings are permitted to equal the street or highway grade.</p> <ul data-bbox="583 662 1747 1063" style="list-style-type: none"> • A landing 4.0 feet minimum by 4.0 feet minimum shall be provided at the bottom of the ramp run and shall be permitted to overlap other landings and clear floor or ground space. • Where a parallel curb ramp does not occupy the entire width of a sidewalk, drop-offs at diverging segments shall be protected. • Detectable warning surfaces shall be provided, where a curb ramp, landing, or blended transition connects to a street. • Gratings, access covers, and other appurtenances shall not be located on curb ramps, landings, blended transitions, and gutters within the pedestrian access route. • Grade breaks shall not be permitted on the surface of curb ramps, blended transitions, landings, and gutter areas within the pedestrian access route. Surface slopes that meet at grade breaks shall be flush. 			
	<ul data-bbox="583 1079 1747 1485" style="list-style-type: none"> • Blended Transitions shall have a running slope of 5 percent maximum and cross slope shall be 2 percent maximum. • The clear width blended transitions, excluding flares, shall be 4.0 feet minimum. • Detectable warning surfaces shall be provided where a blended transition connects to a street. • Gratings, access covers, and other appurtenances shall not be located on blended transitions within the pedestrian access route. • Grade breaks at the top and bottom of perpendicular curb ramps shall be perpendicular to the direction of ramp run. At least one end of the bottom grade break shall be at the back of curb. Grade breaks shall not be permitted on the surface of blended transitions and gutter areas within the pedestrian access route. Surface slopes that meet at grade breaks shall be flush. 			

Figures/Examples	Requirements ¹	YES	NO	NA
 	<ul style="list-style-type: none"> • Diagonal Curb Ramps or corner type curb ramps are no longer preferred design types. A design that provides individual ramps for each crossing direction is recommended by the US Access Board. • Diagonal Curb Ramps or corner type curb ramps with returned curbs or other well-defined edges shall have the edges parallel to the direction of pedestrian flow. • The bottom of diagonal curb ramps shall have a clear space 48 inches minimum outside active traffic lanes of the roadway. • Diagonal curb ramps provided at marked crossings shall provide the 48 inches minimum clear space within the markings. • Diagonal curb ramps with flared sides shall have a segment of curb 24 inches long minimum located on each side of the curb ramp and within the marked crossing. <p><u>Roadway Grade Exception:</u> The grade of pedestrian access routes within sidewalks is permitted to equal the general grade established for the adjacent street or highway. The cross slope of curb ramps, blended transitions, landings, and turning spaces at pedestrian street crossings without yield or stop control where vehicles can proceed through the intersection without slowing or stopping, and at midblock pedestrian street crossings are permitted to equal the street or highway grade.</p> <ul style="list-style-type: none"> • Detectable warning surfaces shall be provided, where a curb ramp, landing, or blended transition connects to a street. • Gratings, access covers, and other appurtenances shall not be located on curb ramps, landings, blended transitions, and gutters within the pedestrian access route. • Grade breaks shall not be permitted on the surface of curb ramps, blended transitions, landings, and gutter areas within the pedestrian access route. Surface slopes that meet at grade breaks shall be flush. • Running and cross slope at midblock crossings shall be permitted to be warped to meet street or highway grade. 			

DETECTABLE WARNINGS DEVICES (TRUNCATED DOMES) (PROWAG R304)

Figures/Examples	Requirements ¹	YES	NO	NA
<p>A surface feature of truncated dome material built in or applied to the walking surface to advise of an upcoming change from pedestrian to vehicular way.</p>	<ul style="list-style-type: none"> • Detectable warnings shall consist of a surface of truncated domes aligned in a square or radial grid pattern complying with 2010 ADA Standards. Detectable warning surfaces shall contrast visually with adjacent gutter, street or highway, or walkway surfaces, either light-on-dark or dark-on-light. • Detectable warning surfaces shall extend 24 inches minimum in the direction of travel and the full width of the curb ramp (exclusive of flares), the landing, or the blended transition. Detectable warning surfaces are required where curb ramps, blended transitions, or landings provide a flush pedestrian connection to the street. • Sidewalk crossings of residential driveways should not generally be provided with detectable warnings, since the pedestrian right-of-way continues across most driveway aprons and overuse of detectable warning surfaces should be avoided in the interests of message clarity. However, where commercial driveways are provided with traffic control devices or otherwise are permitted to operate like public streets, detectable warnings should be provided at the junction between the pedestrian route and the street. • Perpendicular Curb Ramps: Where both ends of the bottom grade break are 5 feet or less from the back of curb, the detectable warning shall be located on the ramp surface at the bottom grade break. Where either end of the bottom grade break is more than 5 feet from the back of curb, the detectable warning shall be located on the lower landing. • Landings and Blended Transitions: The detectable warning shall be located on the landing or blended transition at the back of curb. • Rail Crossings: The detectable warning surface shall be located so that the edge nearest the rail crossing is 6 feet minimum and 15 feet maximum from the centerline of the nearest rail. The rows of truncated domes in a detectable warning surface shall be aligned to be parallel with the direction of wheelchair travel. • Detectable warnings at cut-through islands shall be located at the curb line in-line with the face of curb and shall be separated by a 2.0 foot minimum length of walkway without detectable warnings. Where the island has no curb, the detectable warning shall be located at the edge of roadway. • Exception, when detectable warnings are required by a manufacturer's installation specifications to be embedded into concrete with a surrounding edge, domes may be installed at less than the required full width. Under this exception, the detectable warning surface shall never be more than 2 inches from the edge of the curb ramp, the landing, or the blended transition. ² • Detectable warnings shall not be stamped into concrete. 			

ACCESSIBLE PEDESTRIAN SIGNALS (PUSHBUTTONS) (PROWAG R306 and EPG 902.6.1 – EPG 902.6.15)

Figures/Examples	Requirements ¹	YES	NO	NA
    	<ul style="list-style-type: none"> • Each crosswalk with pedestrian signal indication shall have an accessible pedestrian signal which includes audible and vibrotactile indications of the WALK interval at new signalized intersections and shall be considered at existing intersections being altered or are needing maintenance applications. Where a pedestrian pushbutton is provided, it shall be integrated into the accessible pedestrian signal. • Accessible pedestrian signals shall be located so that the vibrotactile feature can be contacted from the level landing serving a curb ramp, if provided, or from a clear floor or ground space that is in line with the crosswalk line adjacent to the vehicle stop line. • Accessible pedestrian pushbuttons shall be located within a reach range complying with EPG 642. • A clear floor or ground space shall be provided at the pushbutton and shall connect to or overlap the pedestrian access route. <p>Roadway Grade Exception: Clear spaces required at accessible pedestrian signals and pedestrian pushbuttons and at other accessible elements are permitted to have a running slope or cross slope consistent with the grade of the adjacent pedestrian access route.</p> <ul style="list-style-type: none"> • Pedestrian signals shall comply with PROWAG 2005 R306 and EPG 902.6.1 through 902.6.15. <ul style="list-style-type: none"> - Pushbuttons are a minimum 2 inches across in one dimension, raised (not recessed), contrast visually with the housing or mounting, and have a maximum force of 3.5 pounds to activate operable parts. - The control face of the pushbuttons is installed parallel to the direction of the crosswalk it serves. - The location of pushbuttons for new construction are within a longitudinal distance of 5 feet maximum from the crosswalk line, and 30 inches minimum to 6 feet maximum from the curb line. - For audible pedestrian signal devices only, pushbuttons are a minimum 10 feet apart. - Pushbuttons are located at a height of approximately 42 inches, but no higher than 48 inches from the ground and within 10 inch reach from a level paved clear floor or ground space with minimum dimensions of 48 inches x 30 inches positioned for a parallel approach to the pushbutton. For a forward approach space (30 x 48 inches) the allowed reach range is 0 inches. - Where pushbuttons for the visually impaired are installed, tactile signs are to be provided that meet ADA requirements. 			

PEDESTRIAN STREET CROSSINGS (PROWAG R305 and EPG 642)

Figures/Examples	Requirements ¹	YES	NO	NA
	<ul style="list-style-type: none"> • Crosswalks shall contain a pedestrian access route that connects to departure and arrival walkways through any median or pedestrian refuge island. • Marked crosswalks shall be 6 feet wide minimum. • The grade of the pedestrian access route is permitted to equal the general grade established for the adjacent street or highway, except that where pedestrian access routes are contained within pedestrian street crossings a maximum grade of 5 percent is required. • A 5 percent maximum cross slope is specified for pedestrian access routes contained within pedestrian street crossings without yield or stop control. • Crossings with Stop Control: The cross slope shall be 2 percent maximum. • The cross slope at midblock crossings shall be permitted to be warped to meet street or highway grade. • The running slope shall be 5 percent maximum, measured parallel to the direction of pedestrian travel in the crosswalk. • Accessible pedestrian signals and pedestrian pushbuttons provided at pedestrian crossings with pedestrian signals (See EPG 642 for applicability) shall comply with EPG 902.6.8 through 902.6.15. Operable parts shall comply with EPG 902.6.9 – 902.6.15. • Crosswalk pavement marking is 6 inches wide white. • Stop bar is at minimum 4 feet from the crosswalk. • Curb ramps at marked crossings shall be wholly contained within the markings, excluding any flared sides. • Gratings, access covers, and other appurtenances shall not be located on curb ramps, landings, blended transitions, and gutters within the pedestrian access route. • Grade breaks shall not be permitted on the surface of curb ramps, blended transitions, landings, and gutter areas within the pedestrian access route. Surface slopes that meet at grade breaks shall be flush. • Beyond the curb face, a clear space of 4.0 feet minimum by 4.0 feet minimum shall be provided within the width of the crosswalk and wholly outside the parallel vehicle travel lane. 			

ALTERNATE CIRCULATION PATH (PROWAG R302)

Figures/Examples	Requirements ¹	YES	NO	NA
	<ul style="list-style-type: none"> • Alternate circulation paths shall contain a pedestrian access route. • To the maximum extent feasible, the alternate circulation path shall be provided on the same side of the street as the disrupted route. • Where the alternate circulation path is exposed to adjacent construction, excavation drop-offs, traffic, or other hazards, it shall be protected with a pedestrian barricade or channelizing device complying with MUTCD 6F-58, 6F-63, and 6F-66. • Pedestrian barricades and channelizing devices shall be continuous, stable, and non-flexible and shall consist of a wall, fence, or enclosures specified in section 6F-58, 6F-63, and 6F-66 of the MUTCD (incorporated by reference; see PROWAG 2005 R104.2.4). • A detectable continuous bottom edge shall be provided 2 inches maximum above the ground or walkway surface. • Devices shall provide a continuous surface or upper rail at 3.0 feet minimum above the ground or walkway surface. • Support members shall not protrude into the alternate circulation path. 			

BUS BOARDING AND ALIGHTING AREAS (PROWAG R410)

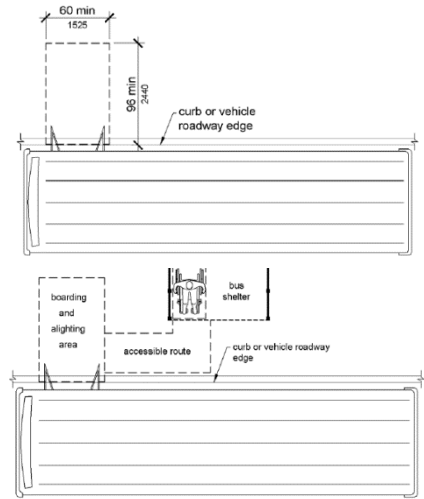
Figures/Examples	Requirements ¹	YES	NO	NA
	<ul style="list-style-type: none"> • Bus stop boarding and alighting areas shall have a firm, stable surface. • Bus stop boarding and alighting areas shall provide a clear length of 8 feet minimum, measured perpendicular to the curb or vehicle roadway edge, and a clear width of 5 feet minimum, measured parallel to the vehicle roadway. • Bus stop boarding and alighting areas shall be connected to streets, sidewalks, or pedestrian paths by an accessible route. • Parallel to the roadway, the slope of the bus stop boarding and alighting area shall be the same as the roadway, to the maximum extent practicable. Perpendicular to the roadway, the slope of the bus stop boarding and alighting area shall not be steeper than 2 percent. • Bus shelters shall provide a minimum 30 inch by 48 inch clear floor or ground space entirely within the shelter. • Bus shelters shall be connected by an accessible route to a boarding and alighting area. 			

¹ Any “NO” answer means that location is ADA non-compliant and needs to be corrected before final acceptance of the work, except as follows. Although exceptions listed in the above requirements may not meet MoDOT current policy standards, work that does meet the minimum ADA standards will be accepted as ADA compliant. Where it is technically infeasible to correct deficiencies as part of the current work, those locations will be labeled as non-compliant and marked “NO”. These items will be added to the Transition Plan Inventory for correction at a later date. (Guidance is provided in ADA documents and in the EPG on what may be considered as technically infeasible.)

² A MoDOT requirement.

Unless otherwise noted, all notes on this form are direct ADA requirements as published in either the PROWAG dated November 23, 2005 or ADA/ABA Standards from 2010.

All exceptions and technically infeasible locations should be discussed with the project manager and/or area engineer prior to acceptance of the work. All exceptions and technically infeasible locations will need to be thoroughly documented by the engineer, and that documentation will be attached to this form and retained as part of the final acceptance records.

All slope and grade measurements for ADA compliance will be made using a calibrated 2 foot long digital level.

US Access Board PROWAG

R202.3.1 Prohibited Reduction in Required Access. An alteration shall not decrease or have the effect of decreasing the accessibility of a facility or an accessible connection to an adjacent building or site below the requirements for new construction in effect at the time of the alteration.

Inspector Name: _____ Inspector Signature: _____	Date:
Contractor Representative Name: _____ Contractor Representative Signature: _____	Date:
Resident Engineer or Area Engineer Name: _____ Resident Engineer or Area Engineer Signature:	Date:
Distribution: <input type="checkbox"/> Project Office <input type="checkbox"/> District Permit Office	

SAMPLE

ADA EXCEPTIONS DOCUMENTATION

Job No. _____ Route _____ County _____ Location _____

<u>Item</u>	<u>Location</u>	<u>Standard</u>	<u>As Built</u>	<u>Discussion</u>
Sidewalk Width	Third Street Sta 3+00 to 7+00 RT	5' wide	Exist 3' wide	Required 5' x 5' Passing Space added at 5+00
Curb Ramp Grade	SE Quad of Main & First	8.33%	11.2%	As-built Curb Ramp is 16.0' long
Parallel Ramp Landing running grade (turning space)	Sta 35+20 to 35+25 Rt Rte 14	2.00%	2.6%	Landing running grade matches existing roadway grade
Sidewalk Grade	Sta 23+45 to 23+52	5.0%	8.4%	Match existing floor at two exist doorways, Straight grade between fixed elevations

Inspector Name: _____	
Inspector Signature: _____	Date:
Resident Engineer or Area Engineer Name: _____	
Resident Engineer or Area Engineer Signature: _____	Date:
Distribution: <input type="checkbox"/> Project Office <input type="checkbox"/> District Permit Office	