

IF A SEAL IS PRESENT ON THIS SHEET IT HAS BEEN ELECTRONICALLY SEALED AND DATED.

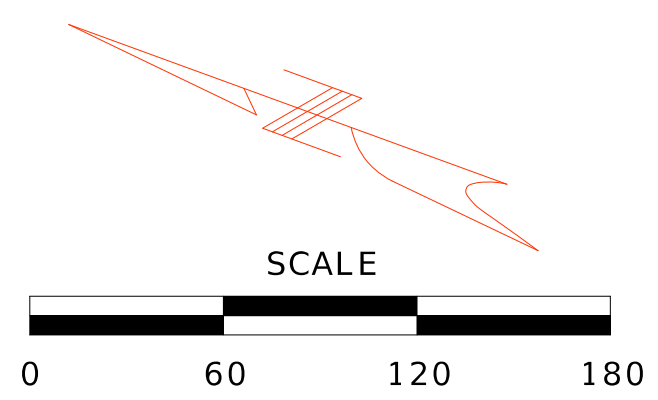
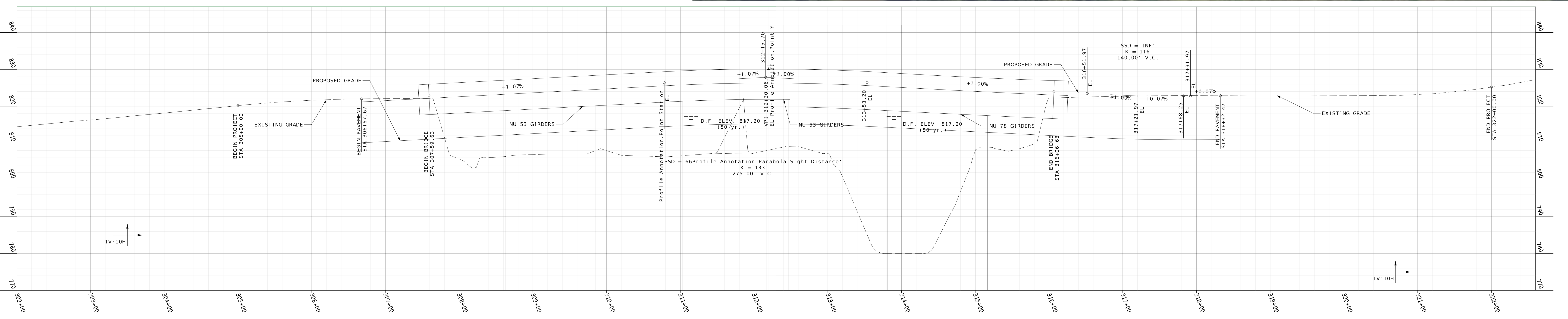
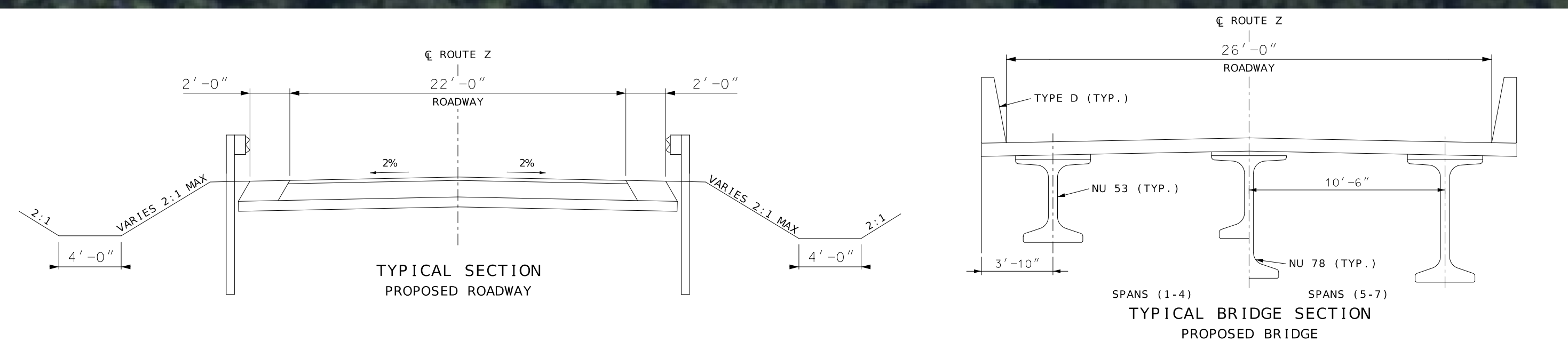

**Bartlett & West**

601 MONROE ST. SUITE 201 - JEFFERSON CITY, MO 65101  
 PHONE 573-634-3181  
 CERTIFICATE OF AUTHORITY NO. 000167 - ENGINEERING  
 WWW.BARTLETTWEST.COM

MISSOURI HIGHWAYS AND TRANSPORTATION COMMISSION

105 WEST CAPITOL  
 JEFFERSON CITY, MO 65102  
 1-888-ASK-MODOT (1-888-275-6636)