

Standard Drawing Guidance (do not show on plans):
 Modify as required.
 Bolted drip angles should only be used when welded drip bars cannot be used.
 ① Drip angles should be located between 5 feet from center of expansion device and 1 foot less from the end of the partial coating limit.

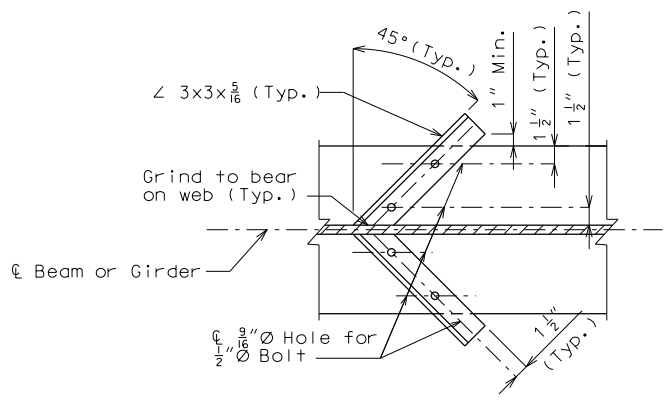

SECTION A-A

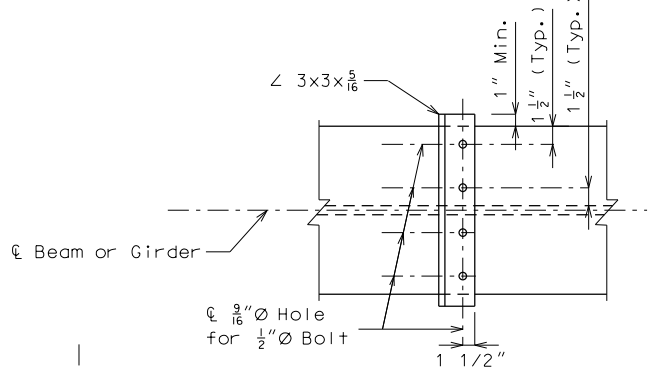

SECTION B-B

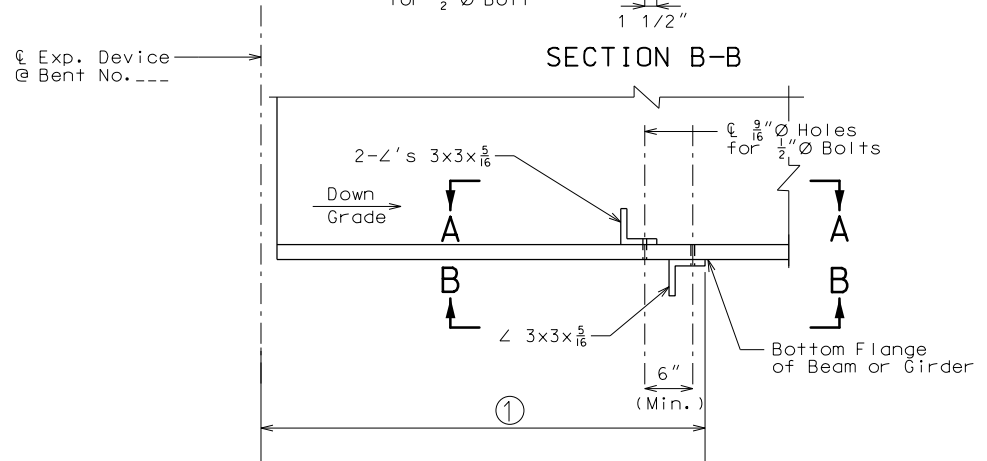

DRIP ANGLES DETAIL

Standard Drawing Guidance (do not show on plans):
 Use this detail near expansion device.
 Use this detail as shown to deflect water from girder.

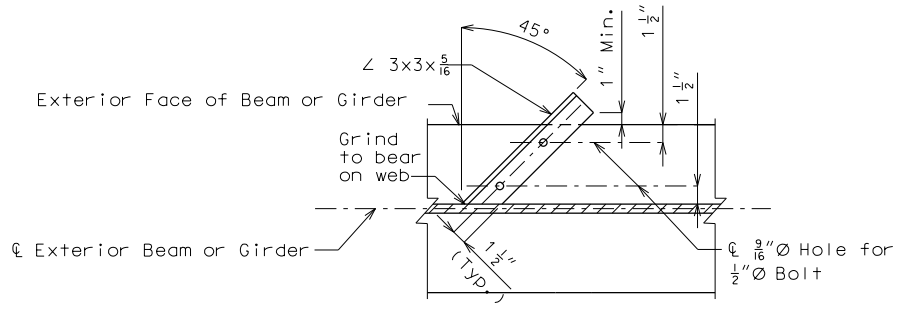

SECTION C-C

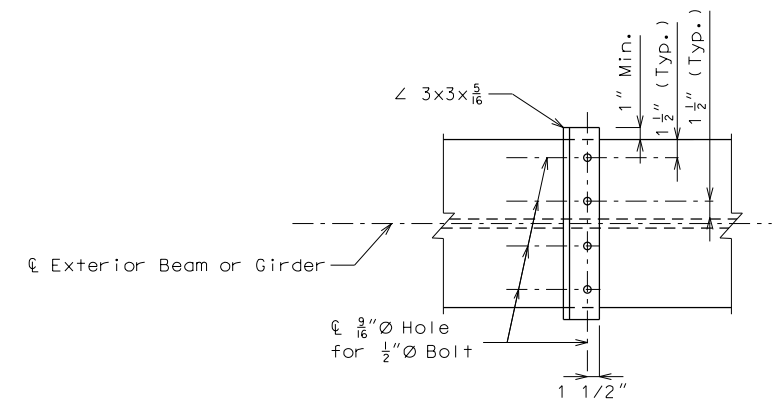

SECTION D-D

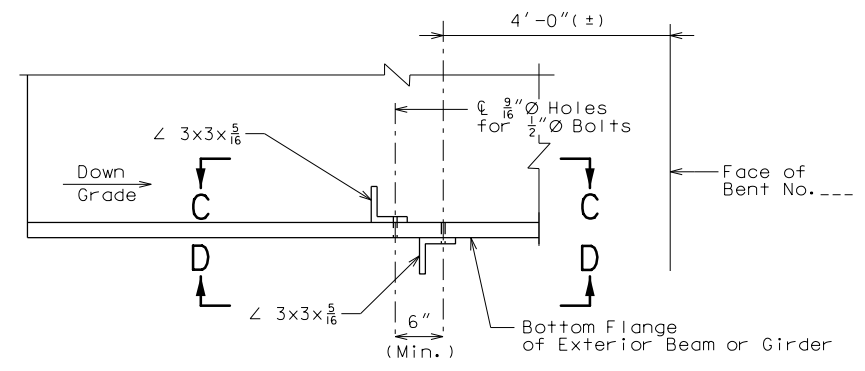

DRIP ANGLES DETAIL

Standard Drawing Guidance (do not show on plans):
 Use this detail near bent.
 Use this detail as shown to deflect water away from bent for exterior girder only.

Note:
 Drip angles shall be caulked with dark brown caulking against flange, web and fillet welds.
 Drip angles shall be same grade as bottom flange.
 Use 1/2"Ø ASTM F3125 Grade A325 Type 3 for bolted connection.

"THIS MEDIA SHOULD NOT BE CONSIDERED A CERTIFIED DOCUMENT."

DATE PREPARED 7/7/2020	
ROUTE *	STATE MO
DISTRICT BR	SHEET NO. *
COUNTY *	
JOB NO. *	
CONTRACT ID. *	
PROJECT NO. *	

BRIDGE NO. DRIP_02	
DESCRIPTION	DATE

MISSOURI HIGHWAYS AND TRANSPORTATION COMMISSION

105 WEST CAPITOL
 JEFFERSON CITY, MO 65102
 1-888-ASK-MODOT (1-888-275-6636)

IF A SEAL IS PRESENT ON THIS SHEET IT HAS BEEN ELECTRONICALLY SEALED AND DATED.