

SECTION A-A

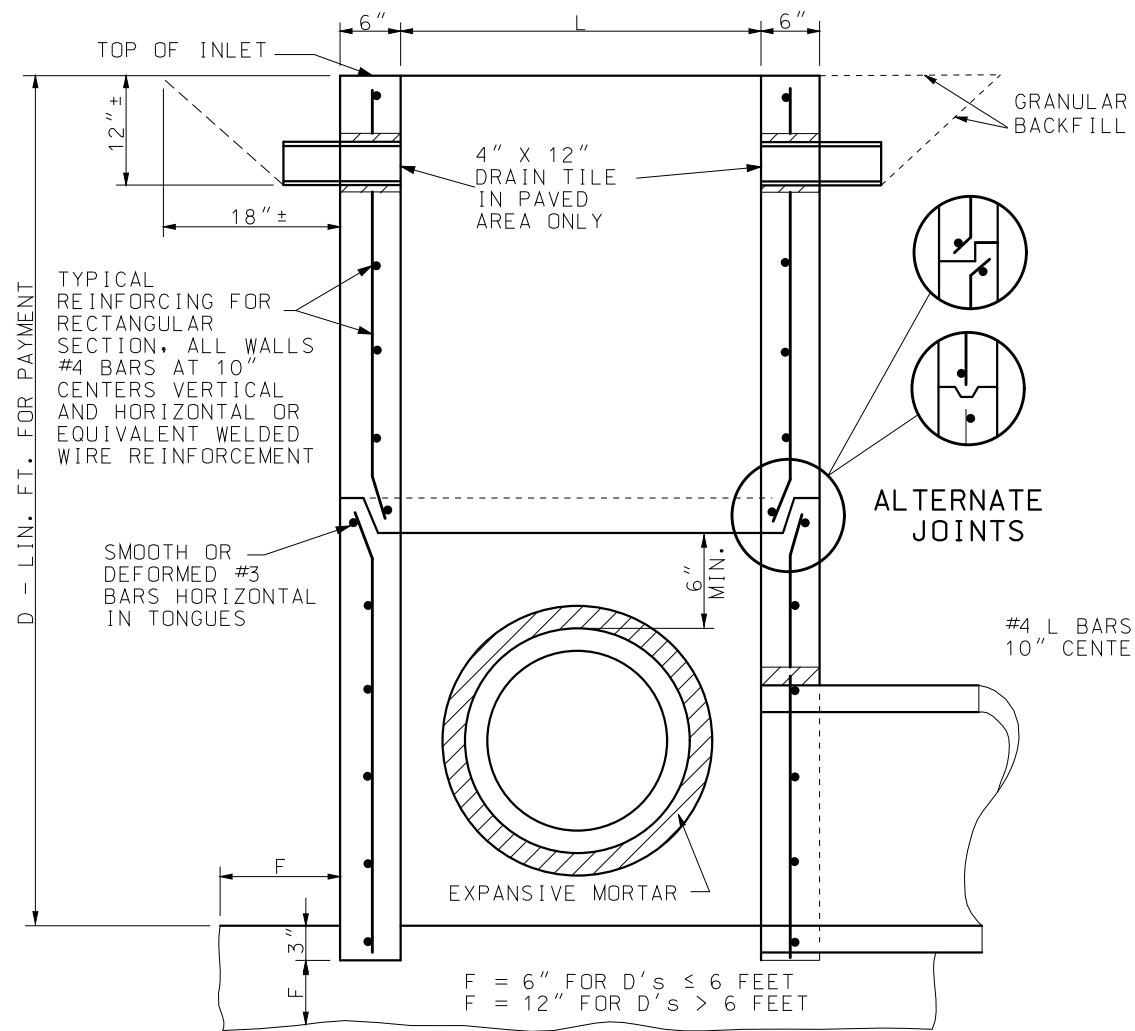

SECTION B-B

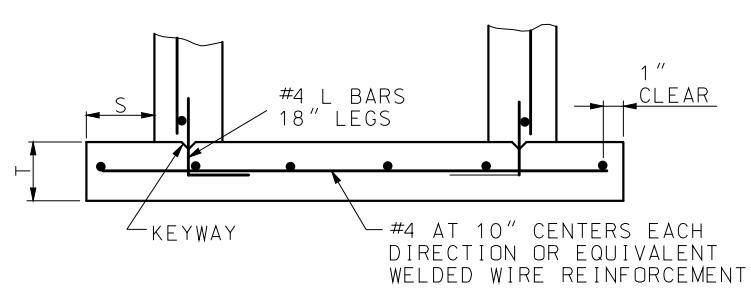

SECTION C-C

S = 0 FOR D ≤ 6 FEET AND 9"  
 FOR D > 6 FEET  
 T = 6" FOR D ≤ 6 FEET AND 9"  
 FOR D > 6 FEET

FOUNDATION SLAB AND BASE SECTION MAY BE POURED MONOLITHIC OR SEPARATELY WITH A KEYWAY.

PRECAST FOUNDATION SLAB

GENERAL NOTES:

STEPS SHALL BE PLACED AT VERTICAL INTERVALS OF 16" MAXIMUM IN ALL INLETS HAVING A DEPTH OF MORE THAN 4 FEET. STEPS SHALL BEGIN AT AN ELEVATION 6" ABOVE THE TOP OF THE OUTLET PIPE.

STEPS SHALL BE SET LEVEL AND IN VERTICAL ALIGNMENT AND NOT NEARER THAT 3" TO A JOINT.

NO DIRECT PAYMENT WILL BE MADE FOR INLET STEPS.

STEPS ARE NOT REQUIRED FOR TYPE D INLETS.

**MoDOT MISSOURI HIGHWAYS AND TRANSPORTATION COMMISSION**  
 105 WEST CAPITOL  
 JEFFERSON CITY, MO 65102  
 1-888-ASK-MODOT (1-888-275-6636)

STATE OF MISSOURI  
 ERIC E. SCHROETER  
 NUMBER PE-28411  
 PROFESSIONAL ENGINEER  
 THIS SHEET HAS BEEN SIGNED, SEALED AND DATED ELECTRONICALLY.

PRECAST DROP INLET

DATE EFFECTIVE: 07/01/2016	731.10S	SHEET NO. 1 OF 8
DATE PREPARED: 5/13/2016		

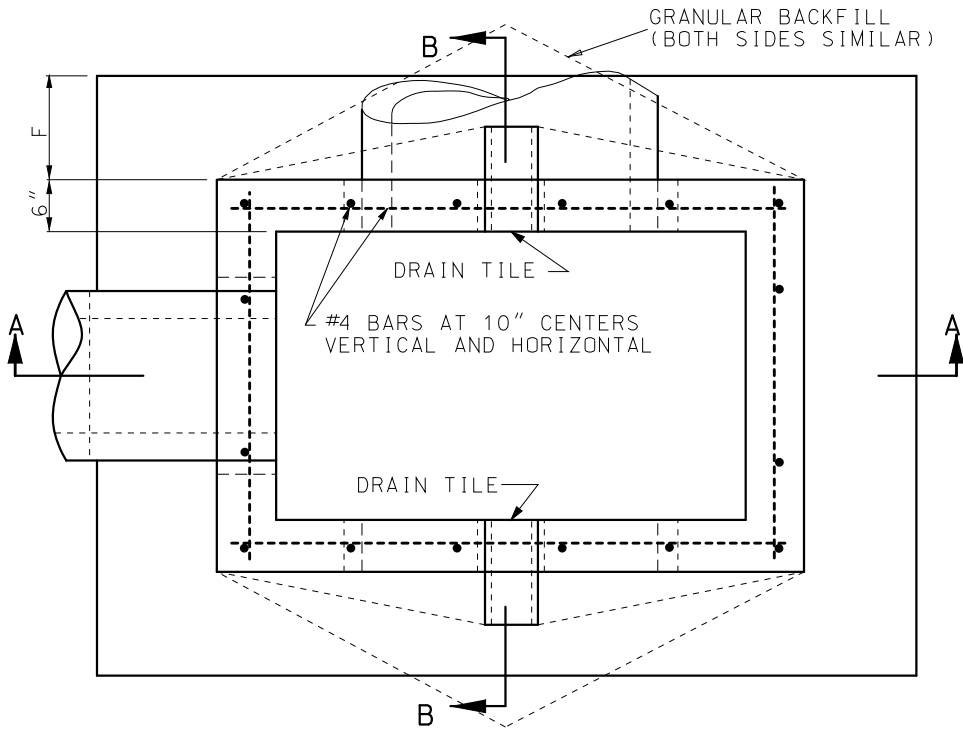

INLET PLAN

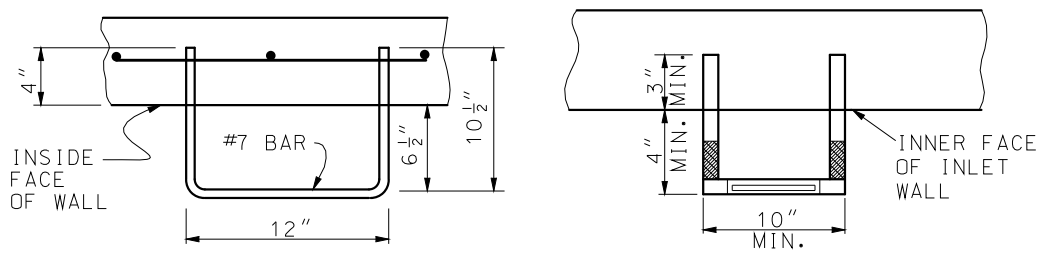

STEPS

STEP INSTALLATION (OTHER THAN STEEL BAR)

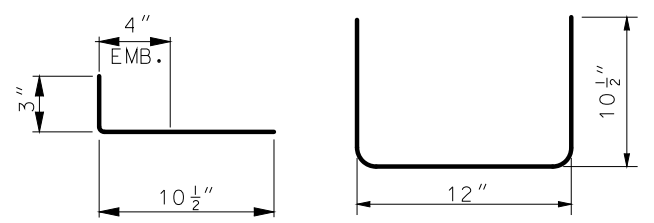

S - BARS

BENDING DIAGRAM STEEL STEP BAR

IF A SEAL IS PRESENT ON THIS SHEET IT HAS BEEN ELECTRONICALLY SEALED AND DATED.

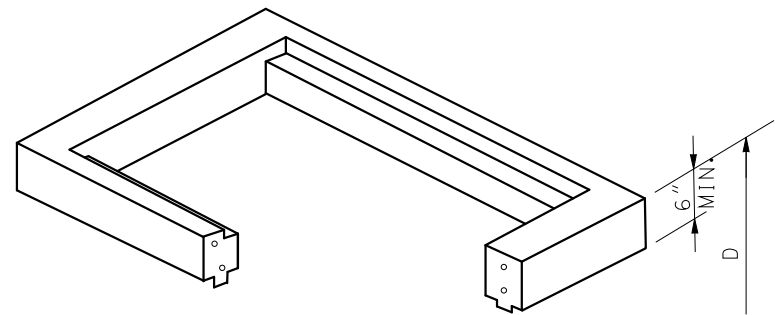

TYPE S-1

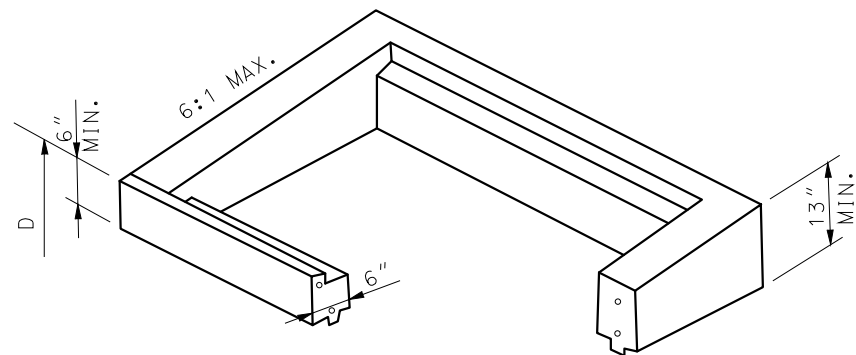

TYPE S-2

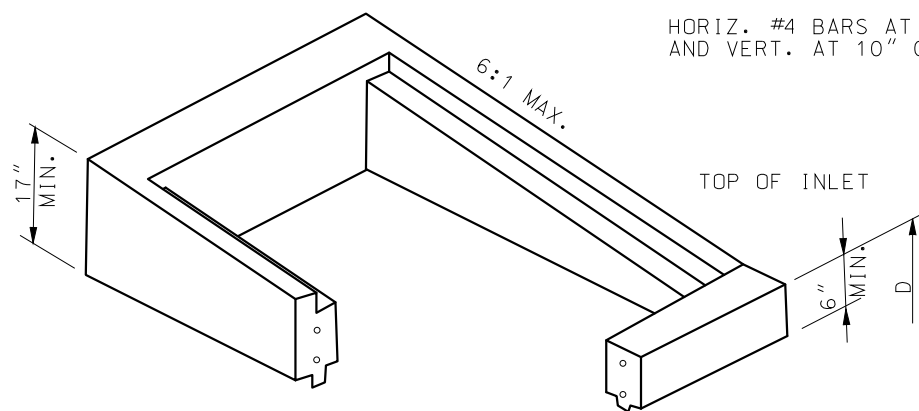

TYPE S-3

HORIZ. #4 BARS AT 6" CTRS.  
AND VERT. AT 10" CTRS.

SEE STANDARD PLAN 614.10 FOR GRATES AND BEARING PLATES. TYPICAL LOCATION DETAILS ARE INDICATED ON SHEETS 7 AND 8 OF 8. TOP SECTIONS MAY BE CAST MONOLITHIC WITH BASE SECTION.

DROP INLET		
WIDTH FT.	LENGTH FT.	TYPE
2	2	A, B, C
4	2	
2	2	D
3	2	E, S-1 S-2, S-3
3	3	
5	2	
5	3	

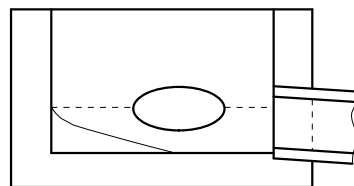
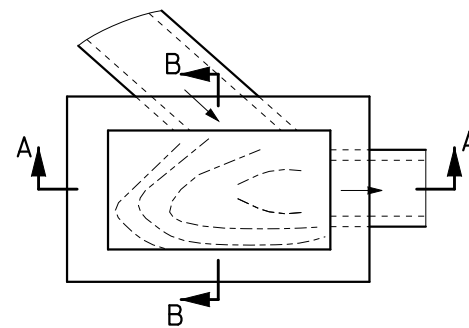

SECTION A-A

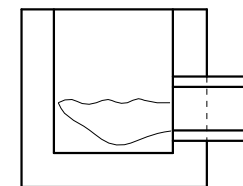

SECTION B-B

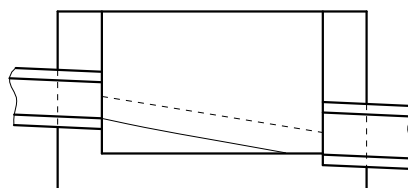
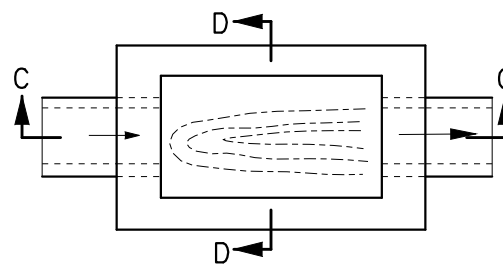

SECTION C-C

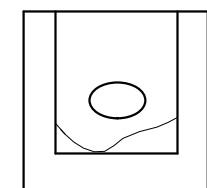

SECTION D-D

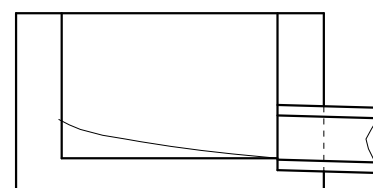
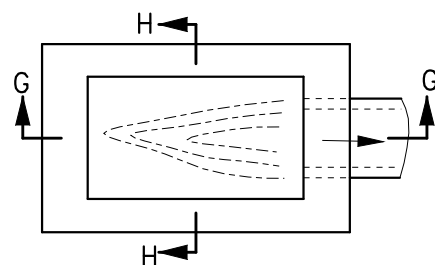

SECTION G-G

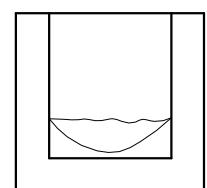

SECTION H-H

TYPICAL INVERTS

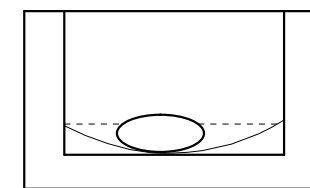
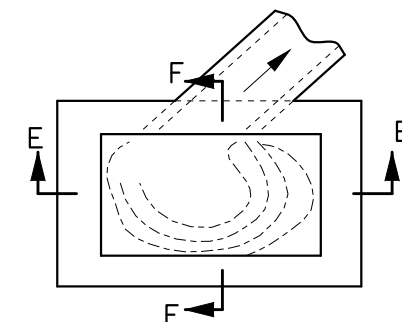

SECTION E-E

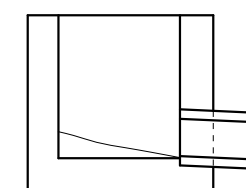

SECTION F-F

GENERAL NOTES:

THE CONCRETE FOR INVERTS SHALL BE PLACED AFTER COMPLETION OF THE DROP INLET BOX. NO DIRECT PAYMENT WILL BE MADE FOR FURNISHING OR PLACING INVERT CONCRETE.

**MoDOT** MISSOURI HIGHWAYS AND TRANSPORTATION COMMISSION  
105 WEST CAPITOL  
JEFFERSON CITY, MO 65102  
1-888-ASK-MODOT (1-888-275-6636)

STATE OF MISSOURI  
ERIC E. SCHROETER  
NUMBER PE-28411  
PROFESSIONAL ENGINEER  
THIS SHEET HAS BEEN SIGNED, SEALED AND DATED ELECTRONICALLY.

PRECAST DROP INLET

DATE EFFECTIVE: 07/01/2016  
DATE PREPARED: 5/13/2016

731.10S

SHEET NO.  
2 OF 8

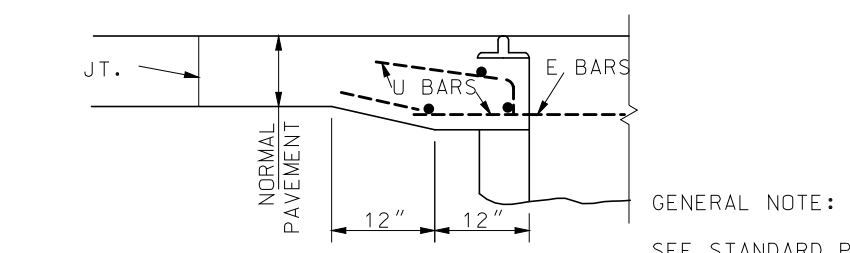
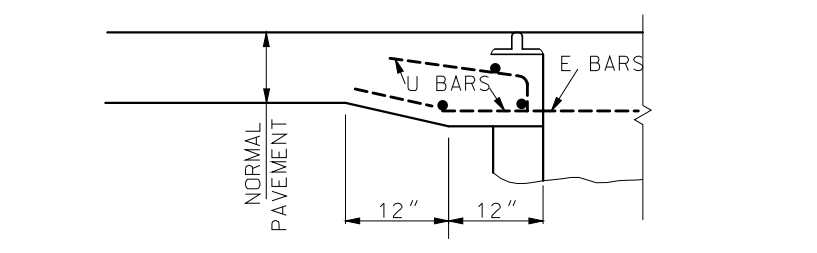
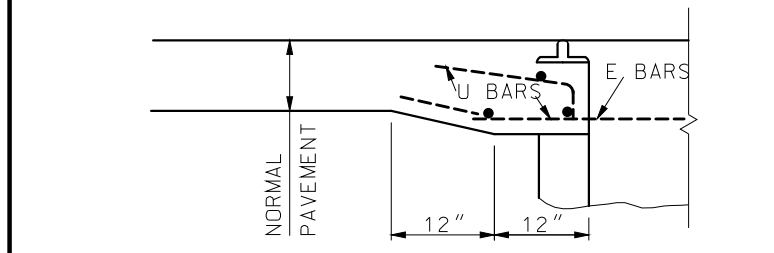
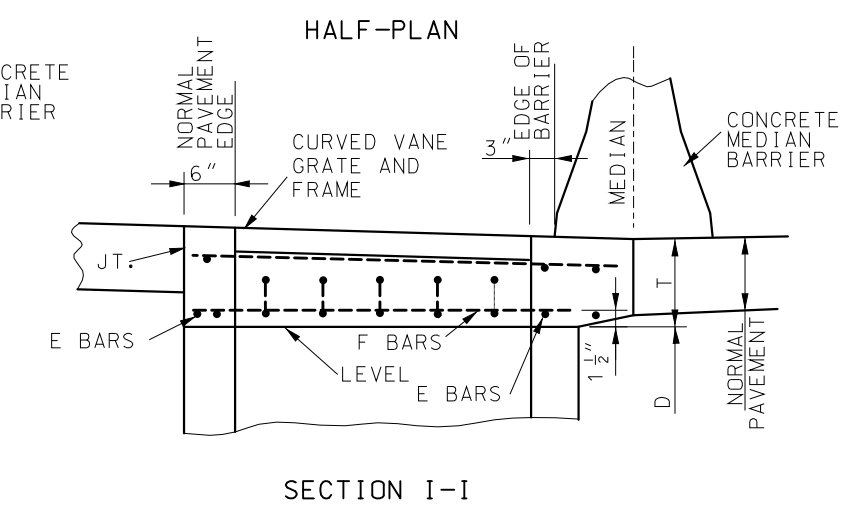
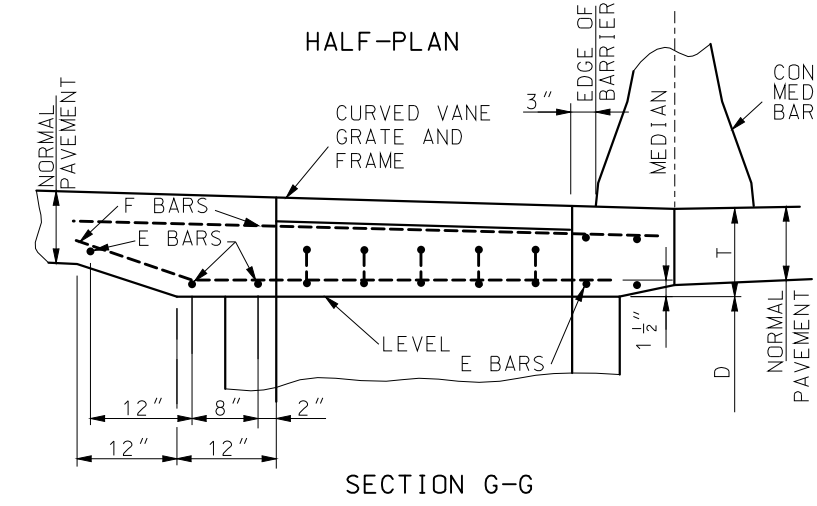
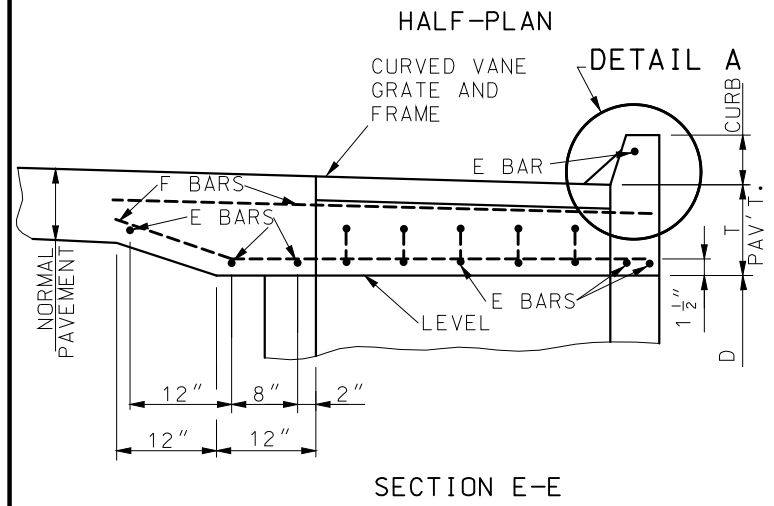
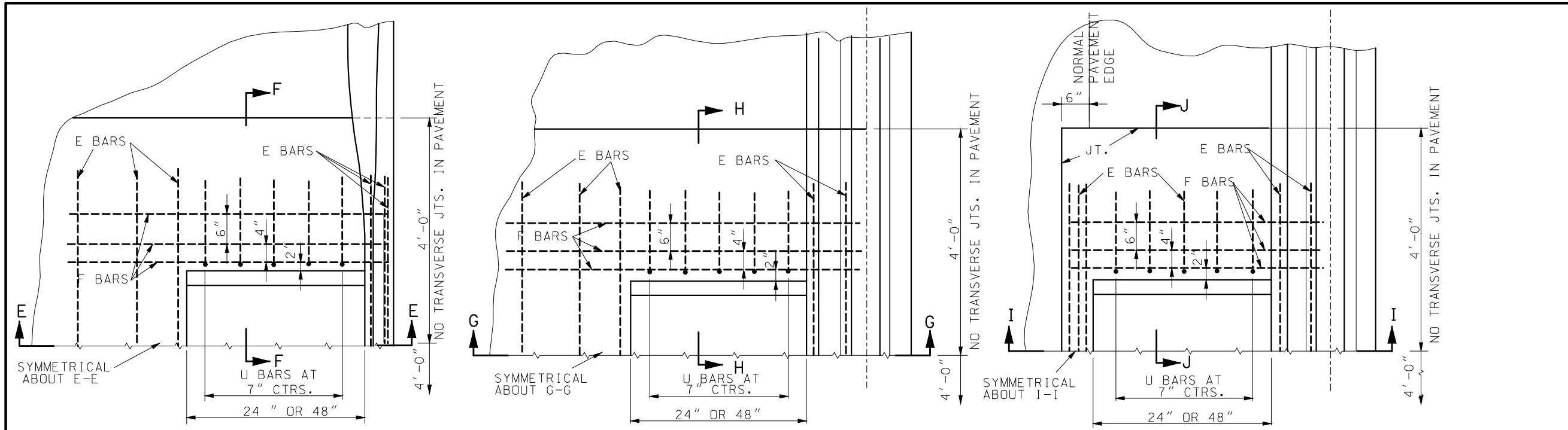

TYPE A  
INLET ADJACENT TO CURB

TYPE B  
DISTANCE BETWEEN BARRIER AND  
PAVEMENT EDGE GREATER THAN INLET WIDTH

TYPE C  
DISTANCE BETWEEN  
BARRIER AND PAVEMENT  
EDGE EQUAL TO INLET WIDTH

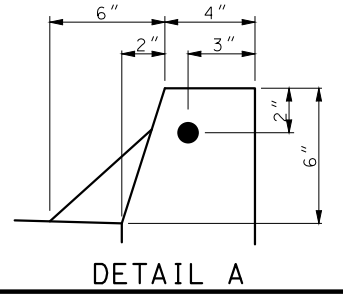

PAVEMENT BAR BILL					
TYPE	WIDTH	LENGTH	MARK	NO.	LENGTH
A	4'	2'	F	6	6'-0"
			F	6	6'-6"
			U	14	2'-9"
	2'	2'	F	6	6'-0"
			F	6	4'-6"
			U	8	2'-9"
B	4'	2'	F	7	6'-0"
			F	6	7'-0"
			U	14	2'-9"
	2'	2'	F	6	5'-0"
			F	6	5'-0"
			U	8	2'-9"
C	4'	2'	F	7	6'-0"
			F	6	5'-3"
			U	14	2'-9"
	2'	2'	F	7	6'-0"
			F	6	3'-3"
			U	8	2'-9"
D	2'	2'	F	6	7'-0"
			F	6	2'-9"
			U	8	2'-9"

BARS E, F, & U.....#4

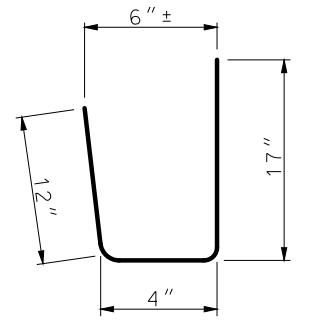

GENERAL NOTE:  
SEE STANDARD PLAN 614.11 FOR CURVED VANE GRATE.

**MoDOT** MISSOURI HIGHWAYS AND TRANSPORTATION COMMISSION  
105 WEST CAPITOL  
JEFFERSON CITY, MO 65102  
1-888-ASK-MODOT (1-888-275-6636)

STATE OF MISSOURI  
ERIC E. SCHROETER  
NUMBER PE-28411  
PROFESSIONAL ENGINEER  
THIS SHEET HAS BEEN SIGNED SEALED AND DATED ELECTRONICALLY.

DATE EFFECTIVE: 07/01/2016	731.10S	SHEET NO. 3 OF 8
DATE PREPARED: 5/13/2016		

IF A SEAL IS PRESENT ON THIS SHEET IT HAS BEEN ELECTRONICALLY SEALED AND DATED.

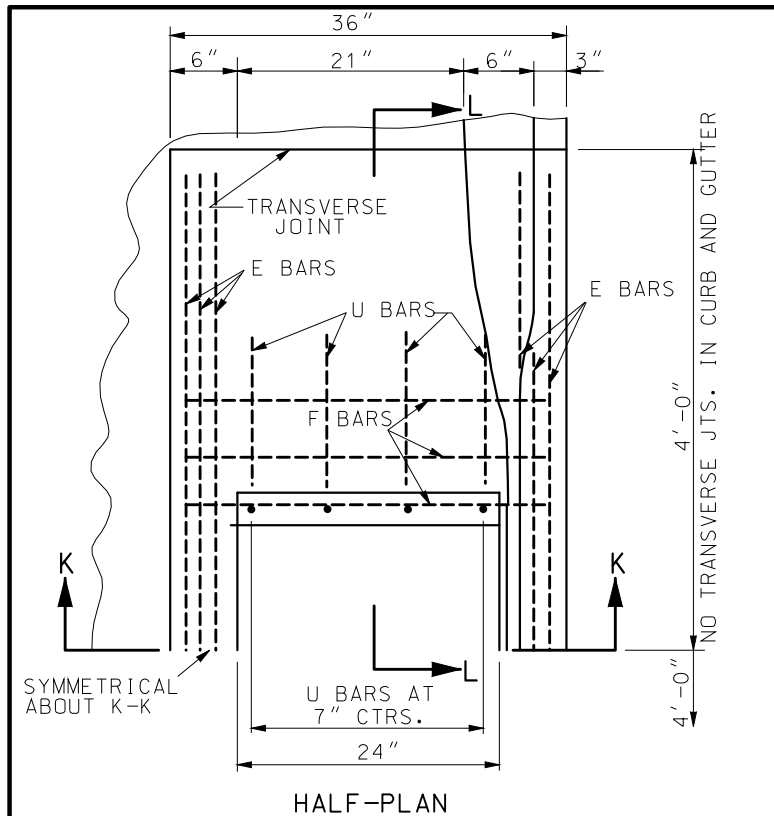

HALF-PLAN

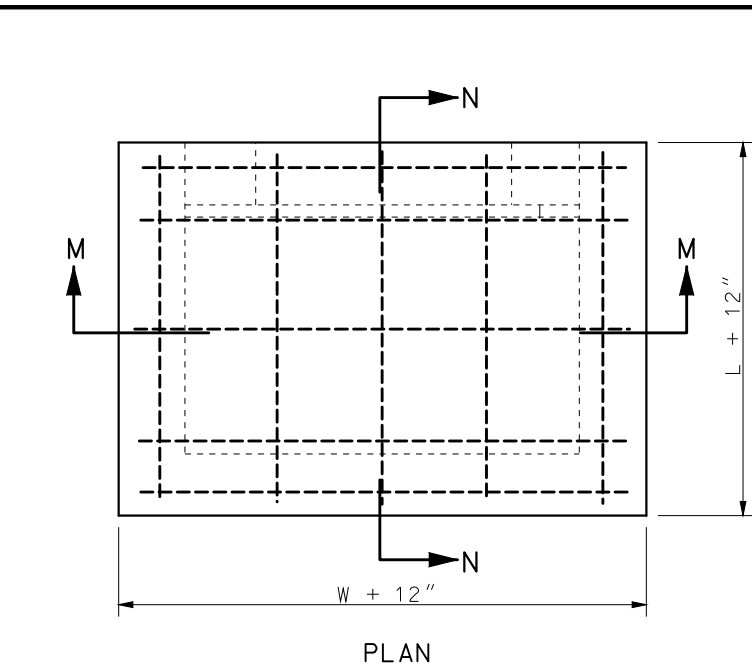

PLAN

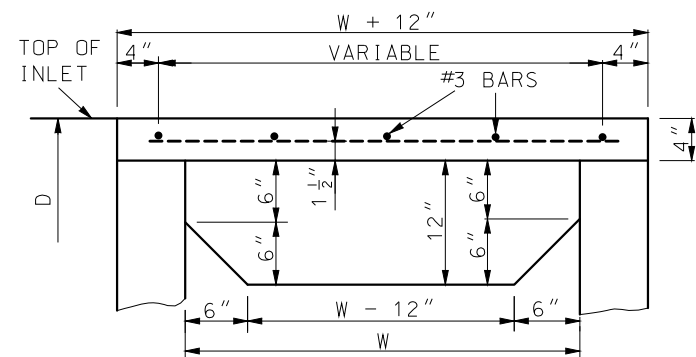

SECTION M-M

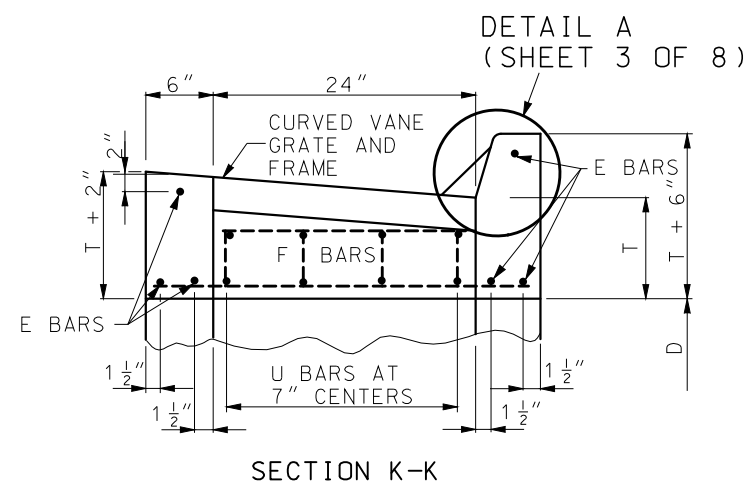

SECTION K-K

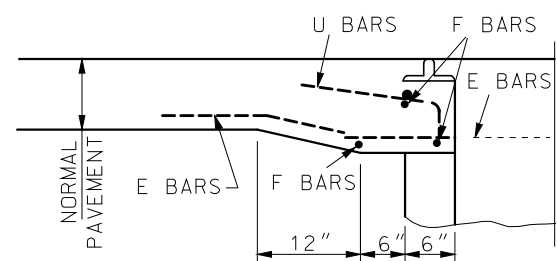

HALF SECTION L-L

TYPE D CURB AND GUTTER

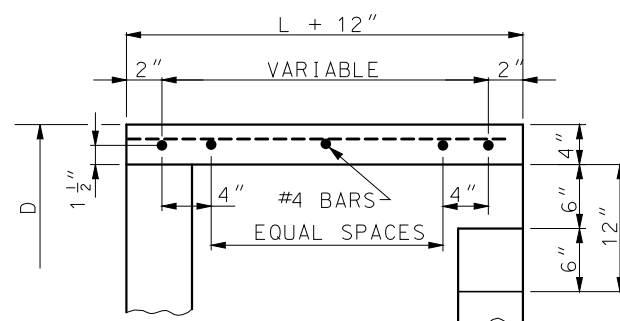

SECTION N-N

TYPE E PRECAST SLAB

PAVEMENT THICKNESS	"T" DIMENSION
LESS THAN OR EQUAL TO 11"	11"
12"	12"
13"	13"
GREATER THAN OR EQUAL TO 14"	14"

TYPE E COVER BAR BILL				
WIDTH	LENGTH	BAR SIZE	NO.	LENGTH
3'	2'	#3	5	2'-9"
		#4	5	3'-9"
3'	3'	#3	5	3'-9"
		#4	5	3'-9"
5'	2'	#3	6	2'-9"
		#4	6	5'-9"
5'	3'	#3	6	3'-9"
		#4	7	5'-9"

GENERAL NOTES:

THE SIZE OF THE DROP INLET AND TYPE OF COVER WILL BE SHOWN ON THE PLANS.

THE CONFIGURATION DETAILS SHOWN ARE DESCRIPTIVE ONLY AND MAY BE VARIED TO CONFORM WITH ESTABLISHED MANUFACTURING PROCEDURES.

TOP OF DROP INLET WALL SHALL BE CONSTRUCTED TO THE ELEVATION OF BOTTOM OF SLAB AT THE EDGE OF PAVEMENT OR BOTTOM OF CURB AND GUTTER AT DROP INLET.

WHERE THE DROP INLET IS LOCATED IN AN UNPAVED AREA, THE TOP OF THE DROP INLET WALLS SHALL BE SET TO THE ELEVATION SHOWN ON THE PLANS.

ALL CONCRETE ABOVE THE TAR PAPER SEPARATION JOINT IS TO BE CONSTRUCTED DURING PAVING OPERATIONS OR CURB AND GUTTER CONSTRUCTION, AND WILL BE PAID FOR AS SQUARE YARDS OF CONCRETE PAVEMENT OR LINEAR FEET OF CURB AND GUTTER.

FORMED OR CUT-OUT OPENINGS SHALL BE PROVIDED WHERE PIPE INLETS AND OUTLETS ARE SHOWN ON THE PLANS.

REINFORCING BARS IN PAVEMENT SHALL BE EPOXY COATED AND SECURELY TIED TOGETHER AND FASTENED TO AVOID ANY POSSIBLE DISPLACEMENT DURING THE PLACING OF CONCRETE. REINFORCEMENT SHOWN IS IN ADDITION TO ANY REINFORCEMENT SHOWN FOR CONCRETE PAVEMENT OR CURB AND GUTTER.

JOINTS SHALL BE SEALED IN ACCORDANCE WITH SECTION 726.3.1 OF THE STANDARD SPECIFICATIONS.

THE CONTRACTOR WILL BE PERMITTED TO CAST IN PLACE THE DROP INLETS CALLED FOR IN THE PLANS, TO THE DIMENSIONS REQUIRED FOR PRECAST DROP INLETS.

WELDED WIRE REINFORCEMENT MAY BE IN LIEU OF REINFORCING BARS, THE REINFORCEMENT SHALL NOT BE LESS THAN .23 SQUARE INCHES PER LINEAR FOOT BOTH HORIZONTALLY AND VERTICALLY.

NO DIRECT PAYMENT WILL BE MADE FOR REINFORCING STEEL.

NO DIRECT PAYMENT WILL BE MADE FOR CUTTING PIPE NOR FOR CUTTING OR BENDING REINFORCING STEEL.

THE TOP OF INLET PIPES SHALL NOT BE SET BELOW THE TOP OF THE OUTLET PIPE.

NO DIRECT PAYMENT WILL BE MADE FOR FORMING FOR CURVED VANE GRATES AND FRAMES.

THE REINFORCEMENT SHOWN IS THE MINIMUM REQUIRED. AT THE CONTRACTOR'S OPTION, ADDITIONAL REINFORCEMENT MAY BE USED.

REINFORCING STEEL EDGE DISTANCE WILL BE 1 1/2" UNLESS OTHERWISE SPECIFIED.

NOT MORE THAN TWO LIFT HOLES OR LIFTING INSERTS MAY BE PROVIDED.

CLASS 3 EXCAVATION WILL BE PAID WITHIN VERTICAL PLANES 18" OUTSIDE OF THE OUTER WALLS OF THE BASE SECTION OF THE DROP INLETS, CLASS 3 EXCAVATION WILL NOT BE PAID FOR OUTSIDE THE FOOTING LIMITS.

**MoDOT** MISSOURI HIGHWAYS AND TRANSPORTATION COMMISSION  
 105 WEST CAPITOL  
 JEFFERSON CITY, MO 65102  
 1-888-ASK-MODOT (1-888-275-6636)

STATE OF MISSOURI  
 ERIC E. SCHROETER  
 NUMBER PE-28411  
 PROFESSIONAL ENGINEER  
 THIS SHEET HAS BEEN SIGNED SEALED AND DATED ELECTRONICALLY.

PRECAST DROP INLET COVERS

DATE EFFECTIVE: 07/01/2016	731.10S	SHEET NO. 4 OF 8
DATE PREPARED: 5/13/2016		

IF A SEAL IS PRESENT ON THIS SHEET IT HAS BEEN ELECTRONICALLY SEALED AND DATED.

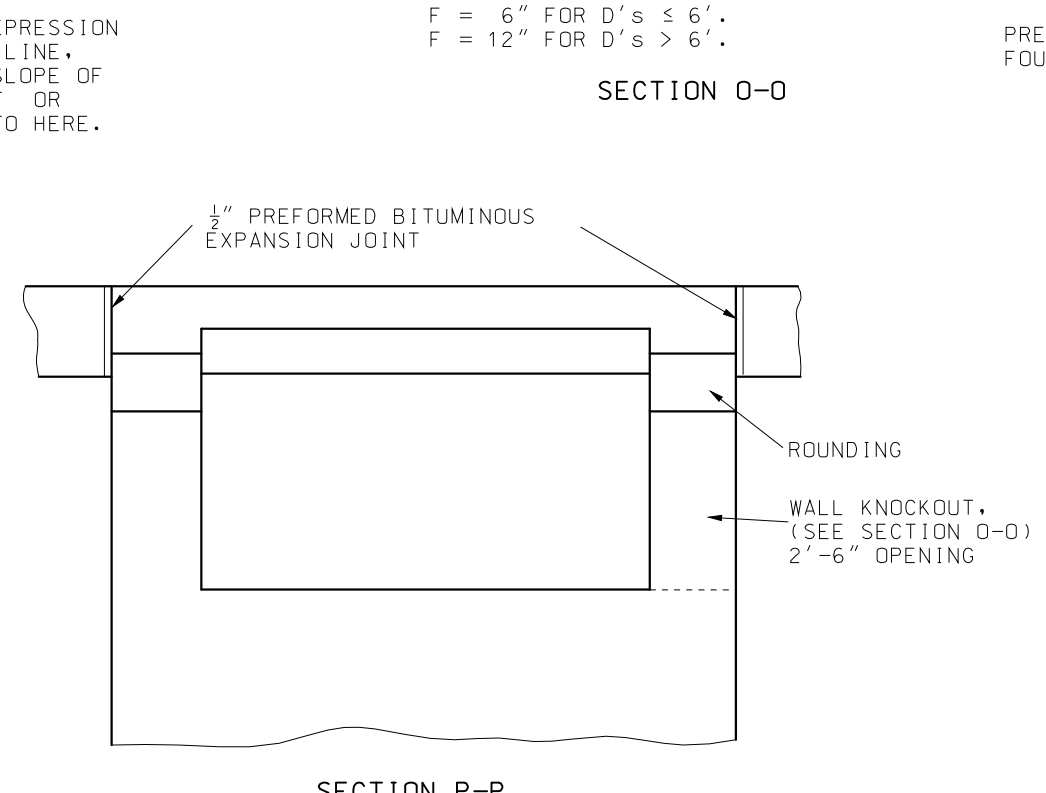
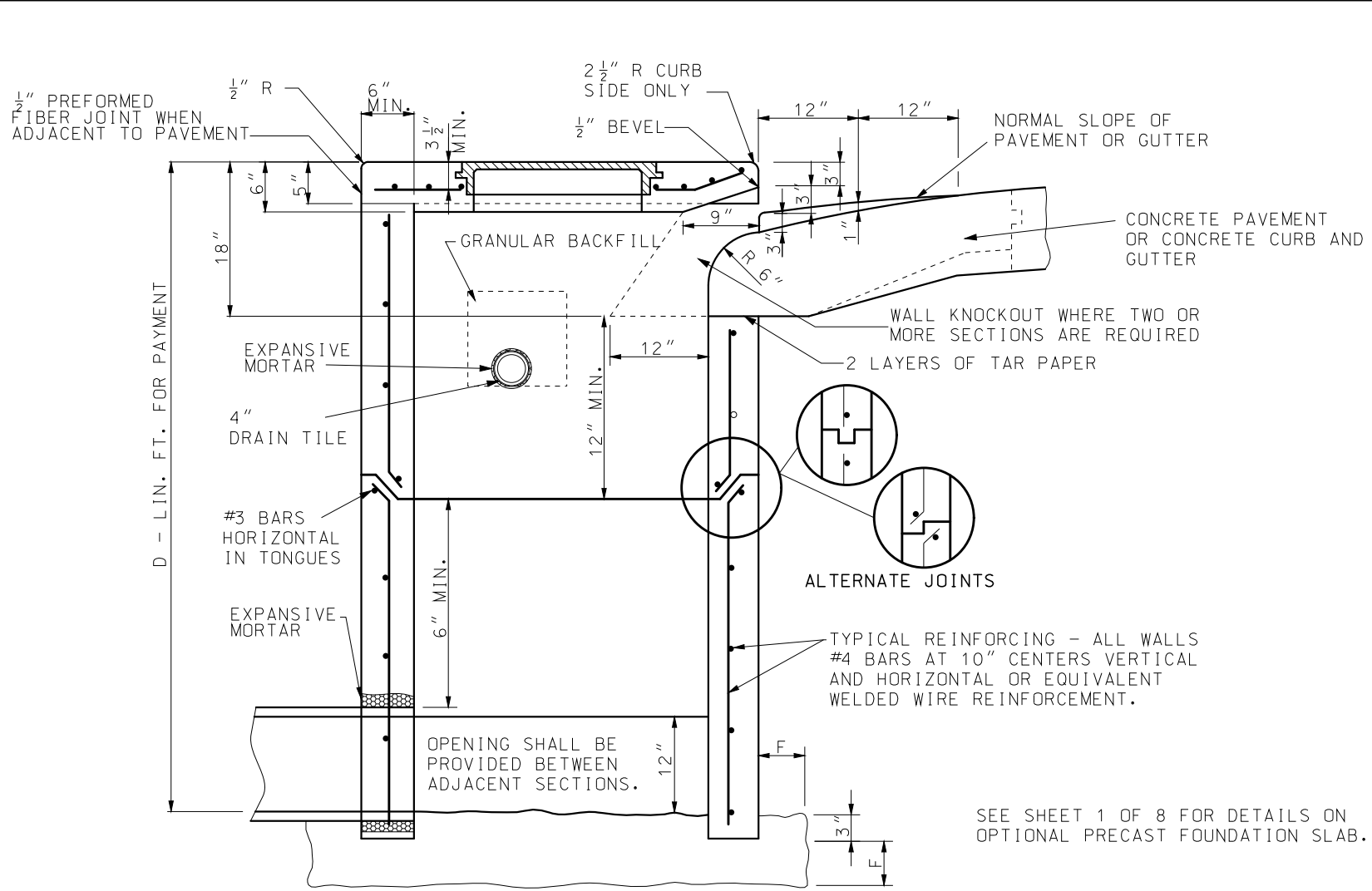
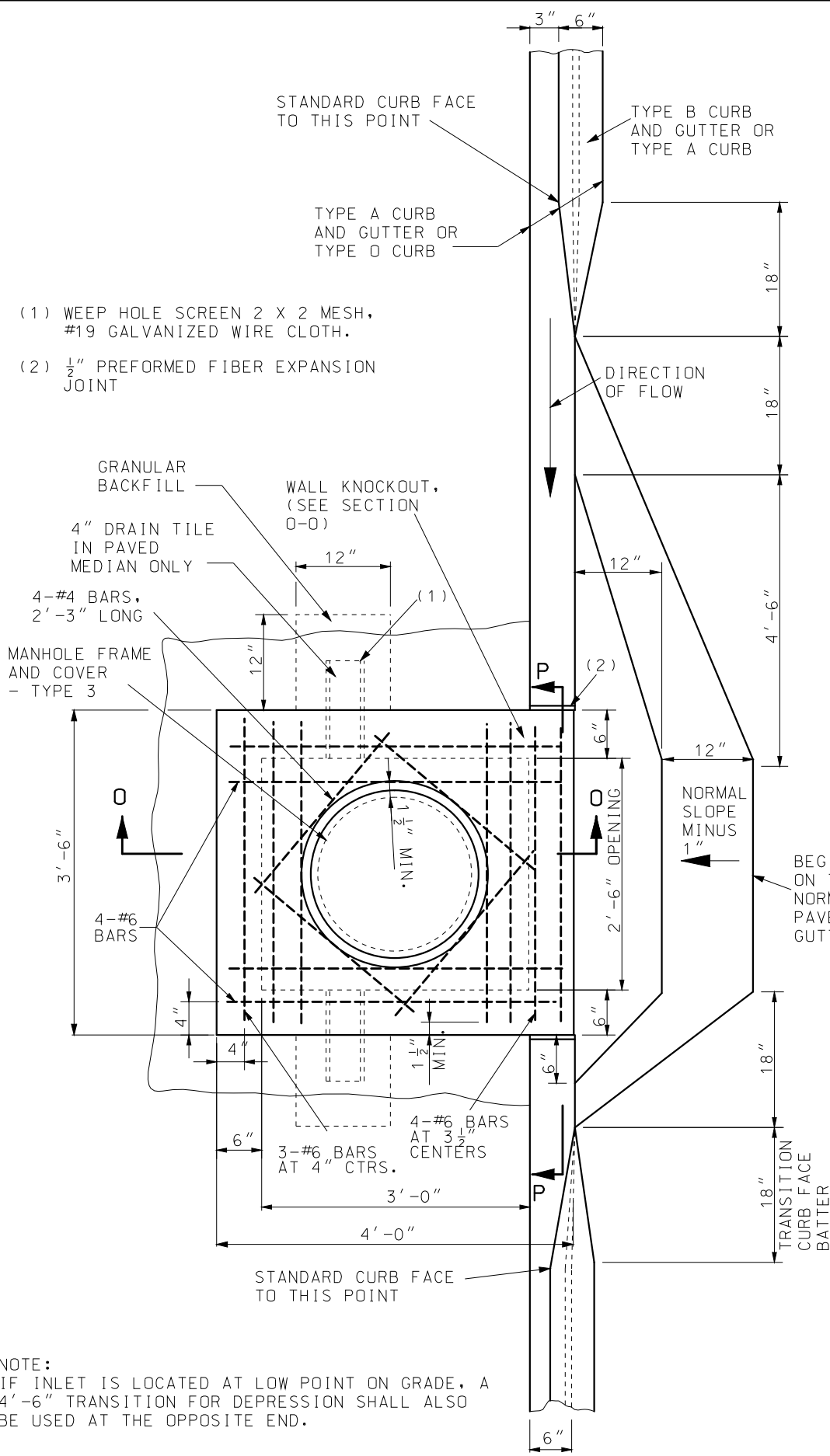

NOTE:  
IF INLET IS LOCATED AT LOW POINT ON GRADE, A 4'-6" TRANSITION FOR DEPRESSION SHALL ALSO BE USED AT THE OPPOSITE END.

**MISSOURI HIGHWAYS AND TRANSPORTATION COMMISSION**

105 WEST CAPITOL  
JEFFERSON CITY, MO 65102  
1-888-ASK-MODOT (1-888-275-6636)

**PRECAST DROP INLET  
CURB INLET - TYPE T**

THIS SHEET HAS BEEN SIGNED, SEALED AND DATED ELECTRONICALLY.

SHEET NO.  
**5 OF 8**

DATE EFFECTIVE:	07/01/2016	731.10S	
DATE PREPARED:	8/11/2016		

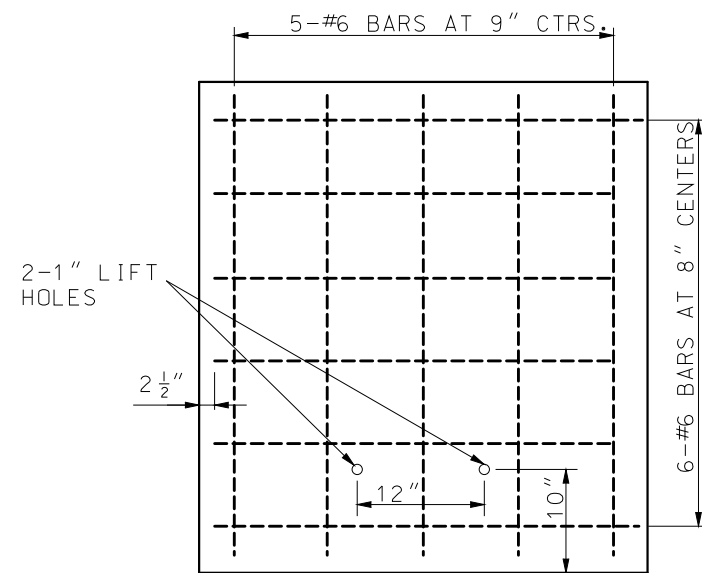

NOTE: REINFORCING FOR LIDS ON UPSTREAM SECTIONS.

LID FOR ADJACENT SECTIONS

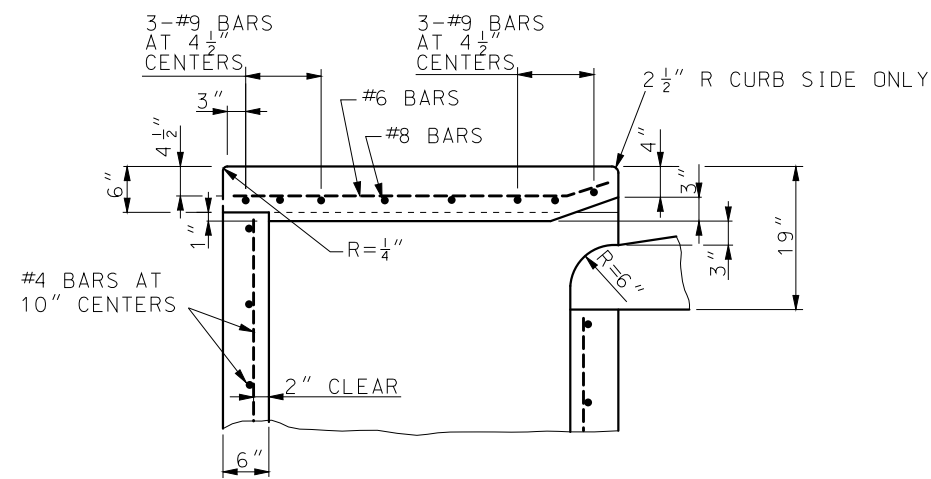
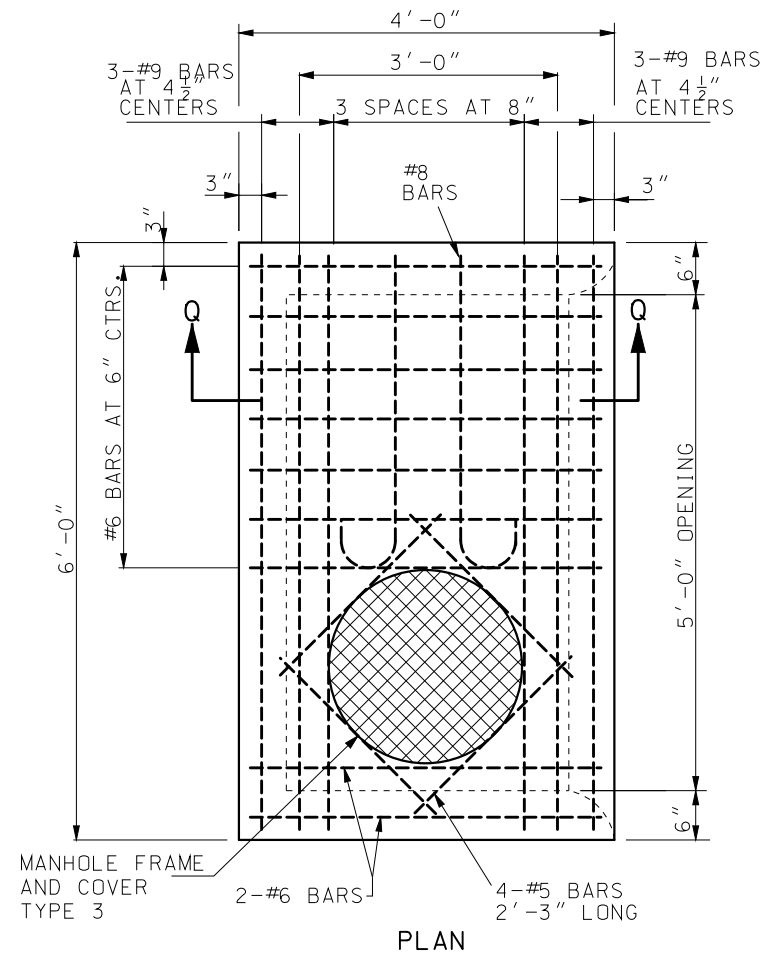

SECTION Q-Q  
 OPTIONAL PRECAST CURB INLET  
 5'-0" OPENING

OTHER DETAILS ARE SAME AS FOR THE 2'-6" OPENING DROP INLET THIS SHEET.

GENERAL NOTES:

NOTES PERTAINING TO TYPE T:

THE LENGTH AND DEPTH OF THE INLET SHALL BE AS SHOWN ON THE PLANS.

WALLS BETWEEN THE ADJACENT SECTIONS SHALL BE SEALED IN ACCORDANCE WITH SECTION 726.3.1 OF THE STANDARD SPECIFICATIONS.

IF DEPTH OF INLET EXCEEDS 6 FEET THE PRECAST UNITS MAY BE FURNISHED IN TWO OR MORE SECTIONS.

IF TWO OR MORE SECTIONS ARE USED, THE TYPE 3 MANHOLE FRAME AND COVER SHALL BE IN THE DOWNSTREAM SECTION ONLY.

IF A 5 FOOT OPENING IS REQUIRED, TWO 2'-6" OPENING SECTIONS OR ONE 5 FOOT OPENING SECTION MAY BE PROVIDED AT THE CONTRACTOR'S OPTION.

SEE SHEET 1 FOR STEP DETAILS AND SHEET 4 FOR GENERAL NOTES.

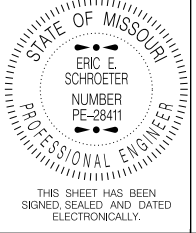
 <b>MISSOURI HIGHWAYS AND TRANSPORTATION COMMISSION</b> 105 WEST CAPITOL JEFFERSON CITY, MO 65102 1-888-ASK-MODOT (1-888-275-6636)	
	<p align="center"><b>PRECAST DROP INLET          CURB INLET - TYPE T</b></p>
DATE EFFECTIVE: 07/01/2016 DATE PREPARED: 5/13/2016	<p align="center"><b>731.10S</b></p>
SHEET NO. <b>6 OF 8</b>	

IF A SEAL IS PRESENT ON THIS SHEET IT HAS BEEN ELECTRONICALLY SEALED AND DATED.

IF A SEAL IS PRESENT ON THIS SHEET IT HAS BEEN ELECTRONICALLY SEALED AND DATED.

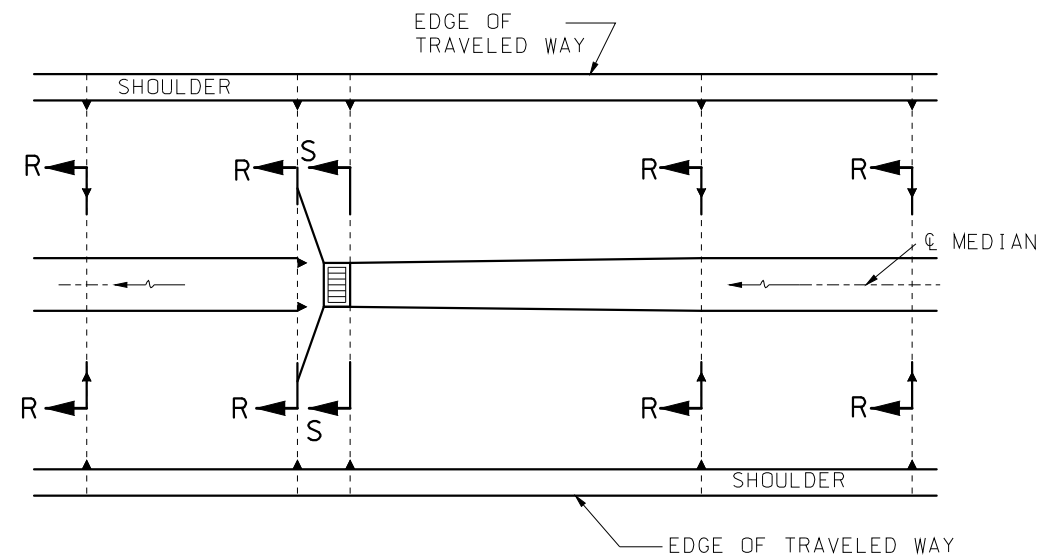

PLAN

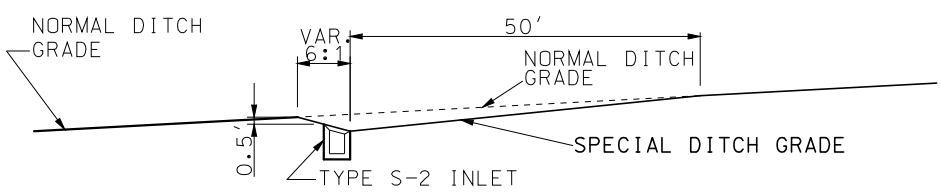

SECTION ALONG CENTERLINE OF MEDIAN RELIEF ON GRADE

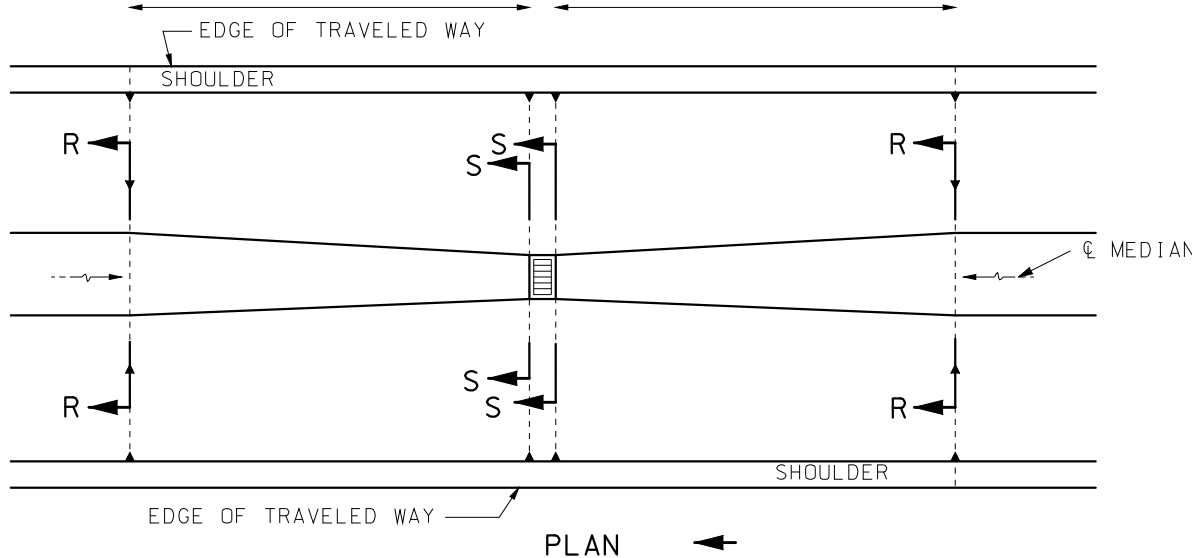

PLAN

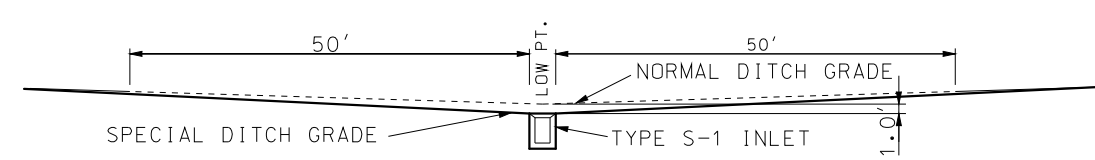

SECTION ALONG CENTERLINE OF MEDIAN RELIEF AT LOW POINT

DETAILS FOR MEDIAN RELIEF-60' MEDIAN

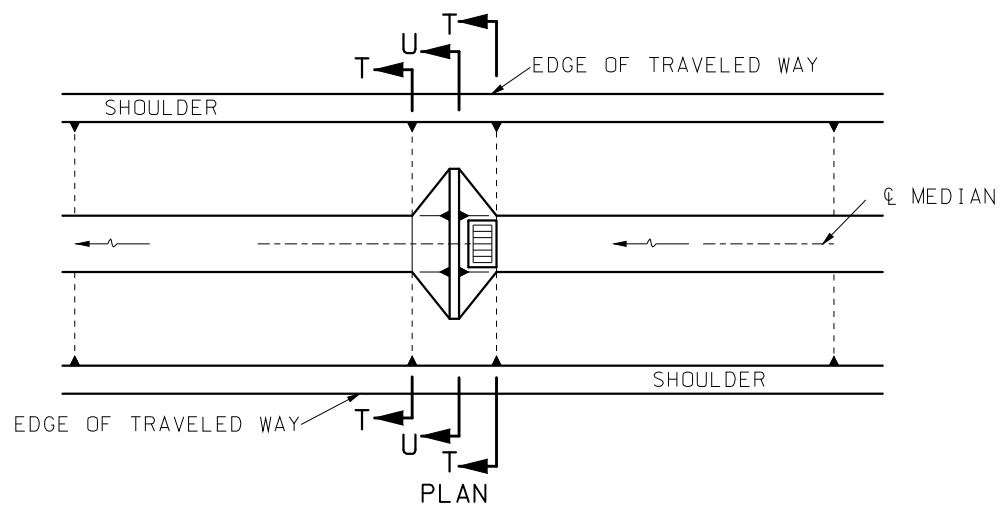

PLAN

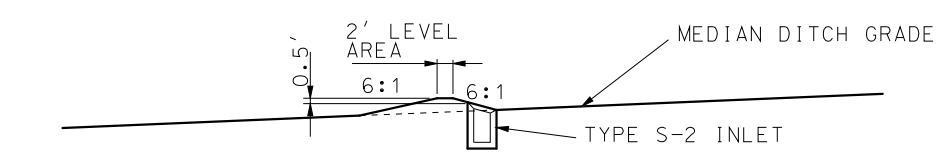

SECTION ALONG CENTERLINE OF MEDIAN RELIEF ON GRADE

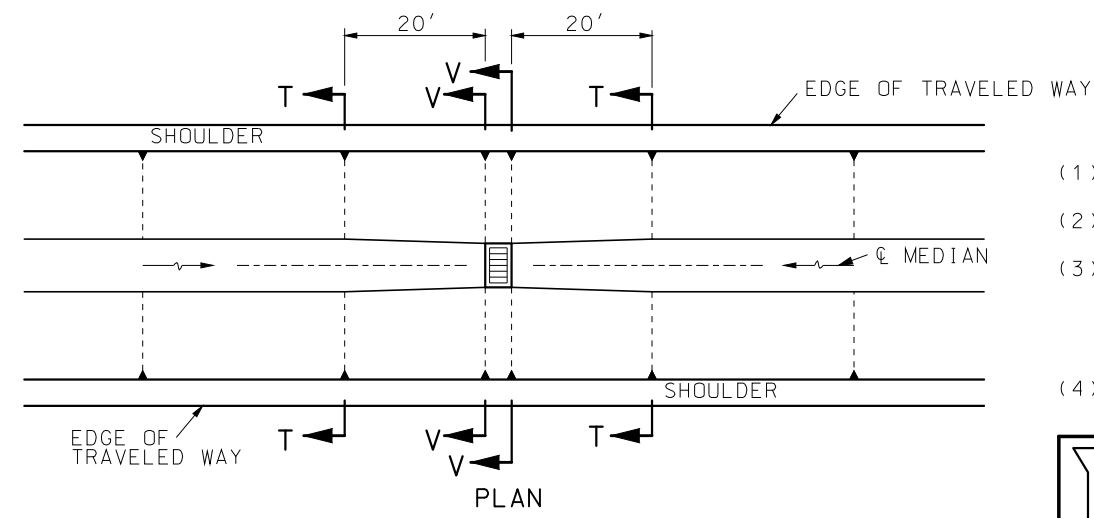

PLAN

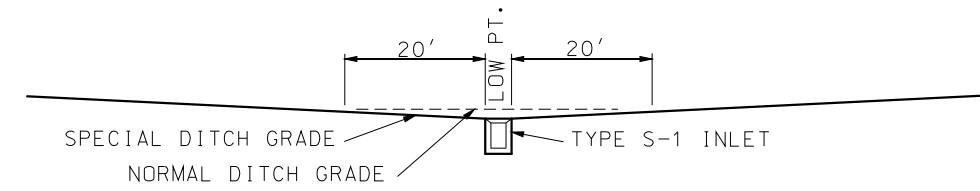

SECTION ALONG CENTERLINE OF MEDIAN RELIEF AT LOW POINT

DETAILS FOR MEDIAN RELIEF-40' MEDIAN

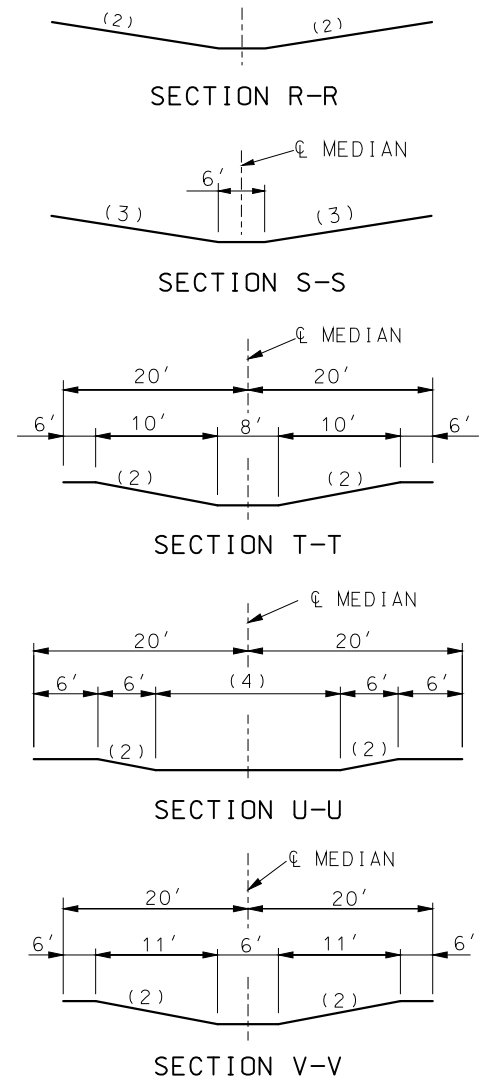

- (1) DITCH WIDTH AS GIVEN ON TYPICAL SECTION.
- (2) DITCH SLOPE AS GIVEN ON TYPICAL SECTION.
- (3) VARY SLOPE TO ACHIEVE MINIMUM 0.5 FT. FREEBOARD ABOVE TOP OF INLET GRATE ON GRADE, OR 1.0 FT. ADDITIONAL DITCH DEPTH BELOW NORMAL DITCH GRADE AT LOW POINT.
- (4) VARY WIDTH TO ACHIEVE MINIMUM .05 FEET FREEBOARD ABOVE TOP OF INLET GRATE.

**MoDOT** MISSOURI HIGHWAYS AND TRANSPORTATION COMMISSION  
 105 WEST CAPITOL JEFFERSON CITY, MO 65102  
 1-888-ASK-MODOT (1-888-275-6636)

STATE OF MISSOURI  
 ERIC E. SCHROETER  
 NUMBER PE-28411  
 PROFESSIONAL ENGINEER  
 THIS SHEET HAS BEEN SIGNED SEALED AND DATED ELECTRONICALLY.

PRECAST DROP INLET  
 TYPICAL LOCATION DETAILS  
 - TYPE S

DATE EFFECTIVE: 07/01/2016	731.10S	SHEET NO. 7 OF 8
DATE PREPARED: 5/13/2016		

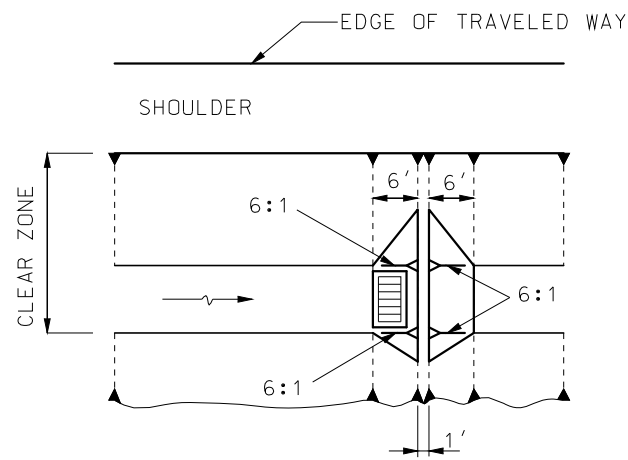

PLAN 1  
TYPE S-2 INLET IN ROADWAY DITCH  
(FLAT DITCH ON GRADE)

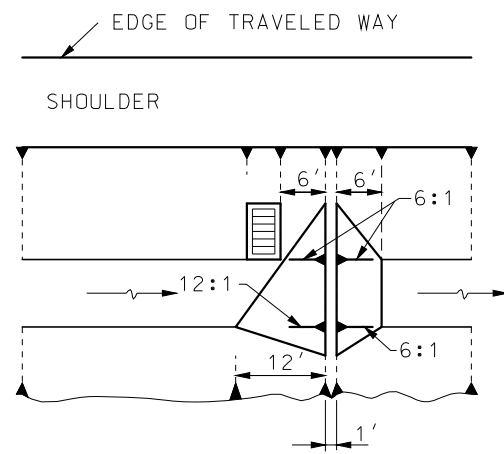

PLAN 2  
TYPE S-3 INLET IN ROADWAY DITCH  
(FLAT DITCH ON GRADE)

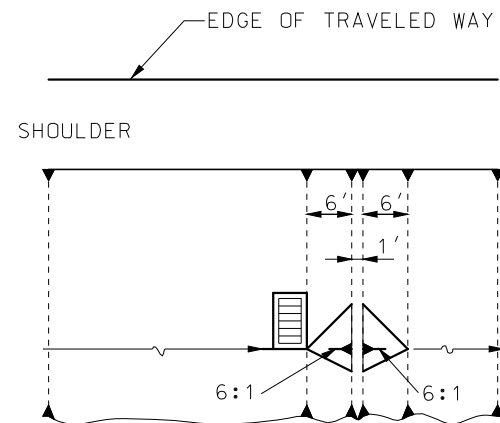

PLAN 3  
TYPE S-3 INLET IN ROADWAY DITCH  
(V DITCH ON GRADE)

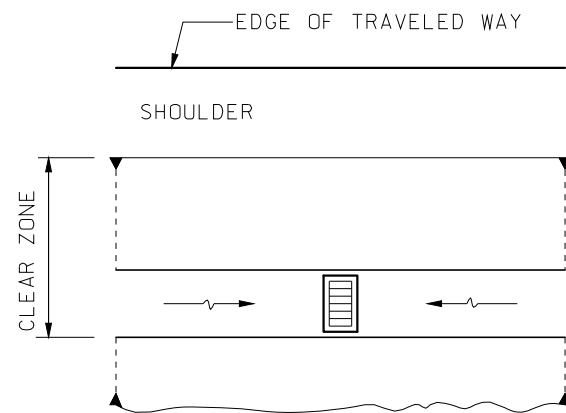

PLAN 4  
TYPE S-1 INLET AT LOW POINT  
(FLAT DITCH)

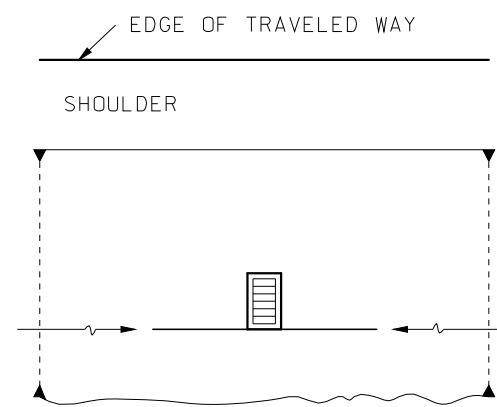

PLAN 5  
TYPE S-3 INLET AT LOW POINT  
(LOW DITCH)

DETAILS FOR ROADWAY DITCH INLETS  
LOCATED WITHIN THE CLEAR ZONE

GENERAL NOTES:

THIS DRAWING IS FOR GENERAL INFORMATION ONLY. ACTUAL CONSTRUCTION DETAILS SHALL CONFORM TO THOSE SHOWN ON THE DETAIL PLANS.

DETAILS ON THIS SHEET ARE ONLY FOR USE WITH STRUCTURES LOCATED IN THE MEDIAN OR WITHIN THE CLEAR ZONE.

**MoDOT** MISSOURI HIGHWAYS AND TRANSPORTATION COMMISSION  
105 WEST CAPITOL  
JEFFERSON CITY, MO 65102  
1-888-ASK-MODOT (1-888-275-6636)

STATE OF MISSOURI  
ERIC E. SCHROETER  
NUMBER PE-28411  
PROFESSIONAL ENGINEER  
THIS SHEET HAS BEEN SIGNED, SEALED AND DATED ELECTRONICALLY.

PRECAST DROP INLET  
TYPICAL LOCATION DETAILS  
- TYPE S

DATE EFFECTIVE: 07/01/2016  
DATE PREPARED: 5/13/2016

731.10S

SHEET NO.  
8 OF 8

IF A SEAL IS PRESENT ON THIS SHEET IT HAS BEEN ELECTRONICALLY SEALED AND DATED.