

EXPRESSWAY DIVIDED

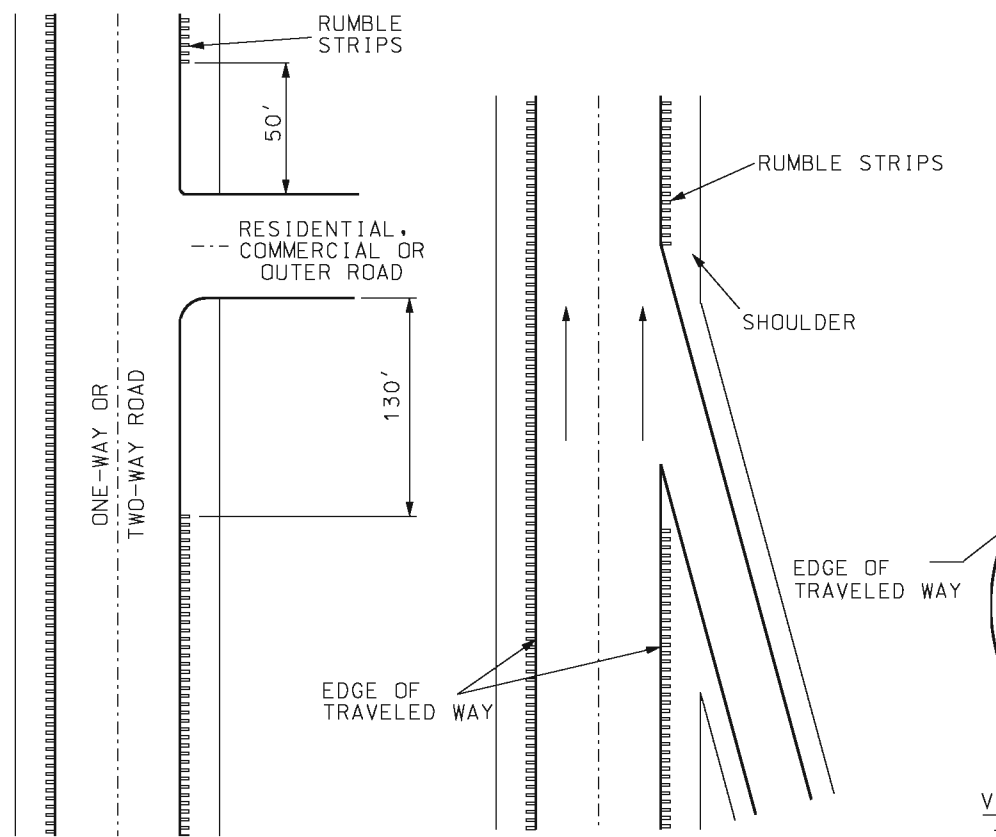

INTERSECTIONS

ACCELERATION OR DECELERATION LANE

RUMBLE STRIP LAYOUTS

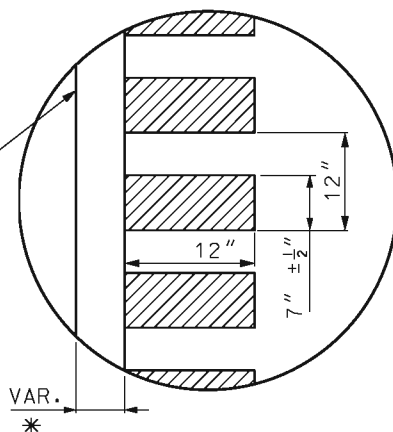

RUMBLE STRIP PLAN VIEW

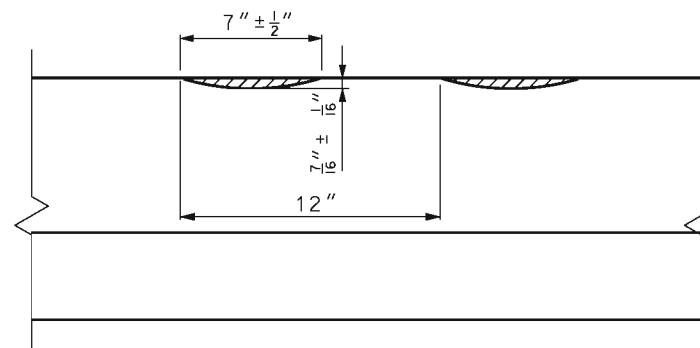

RUMBLE STRIP CROSS SECTION VIEW

14' PAVEMENT STRUCTURES, ALL SHOULDER TYPES	
13' PAVEMENT STRUCTURES, ALL SHOULDER TYPES	
PAVEMENT STRUCTURES ≤ 12' WITH A2 SHOULDER	
PAVEMENT STRUCTURES ≤ 12' WITH A3 SHOULDER	
PAVEMENT STRUCTURES ≤ 12' WITH EARTH OR AGGREGATE SHOULDERS	

* = LATERAL DEVIATION SHALL NOT EXCEED ONE INCH IN 100 FEET.

GENERAL NOTES:

- SEE STANDARD PLAN 620.00 FOR PAVEMENT MARKING.
- RUMBLE STRIPS SHALL BE OMITTED IF SHOULDERS ARE LESS THAN 2' WIDE.
- ALL RUMBLE STRIPS SHALL BE MILLED.
- RUMBLE STRIPS SHALL NOT BE MILLED ONTO TRANSVERSE JOINTS.
- RUMBLE STRIPS SHALL NOT BE PLACED ON BRIDGES.

	<p>MISSOURI HIGHWAYS AND TRANSPORTATION COMMISSION</p>
<p>105 WEST CAPITOL JEFFERSON CITY, MO 65102 1-888-ASK-MODOT (1-888-275-6636)</p>	
	<p>RUMBLE STRIPS SHOULDER</p>
<p>DATE EFFECTIVE: 04/01/2009 DATE PREPARED: 2/20/2009</p>	<p>626.00H SHEET NO. 1 OF 2</p>

IF A SEAL IS PRESENT ON THIS SHEET IT HAS BEEN ELECTRONICALLY SEALED AND DATED.

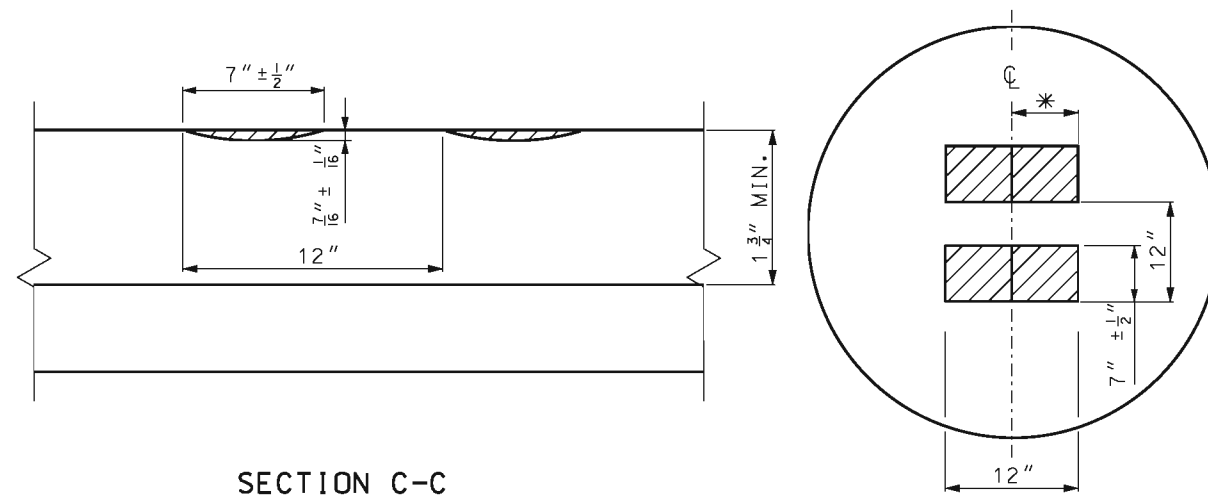

* = LATERAL DEVIATION SHALL NOT EXCEED ONE INCH IN 100 FEET.

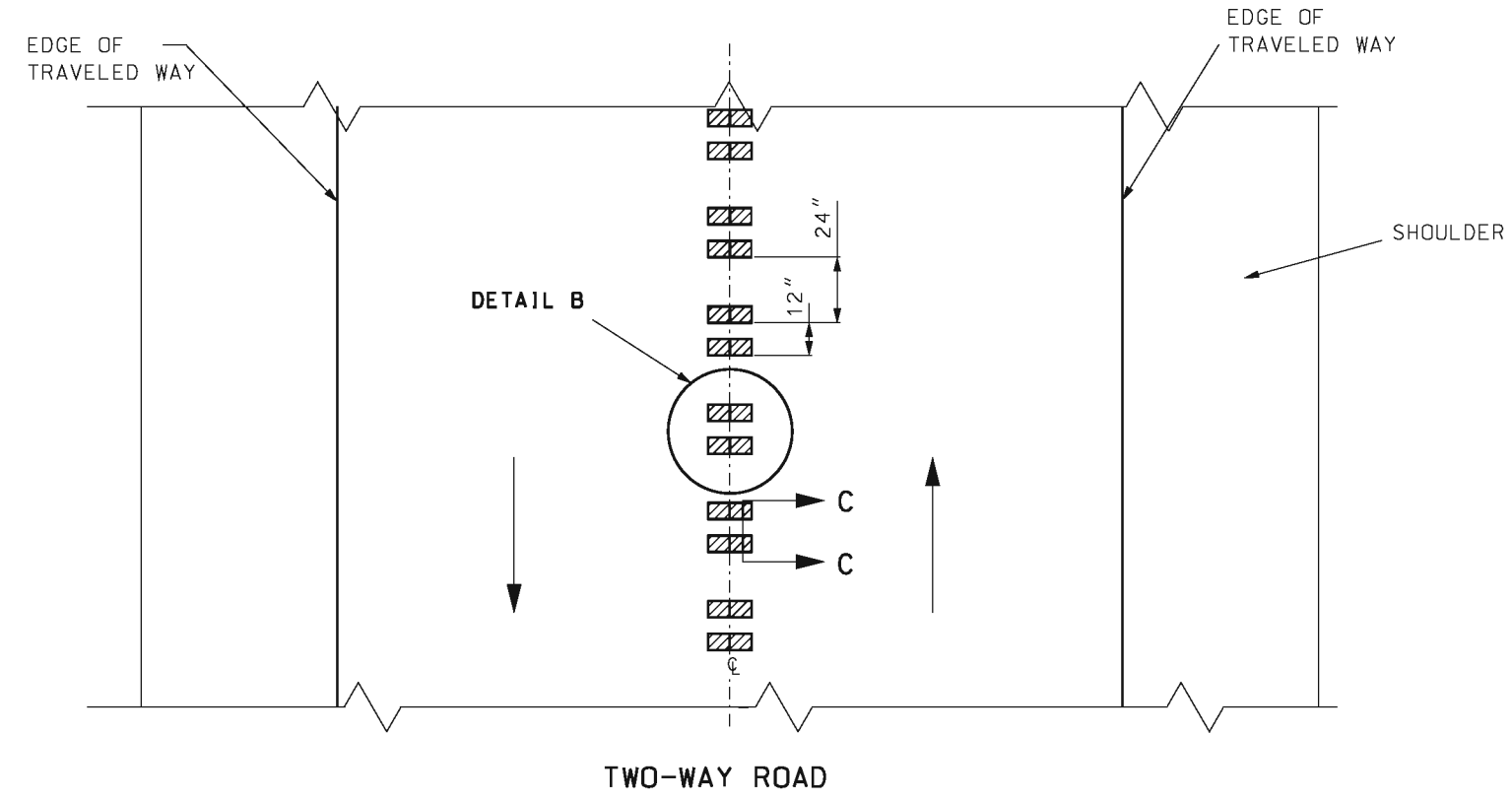

GENERAL NOTES:
 SEE STANDARD PLAN 620.00 FOR PAVEMENT MARKING.
 RUMBLE STRIPS SHALL NOT BE PLACED ON BRIDGES.
 ALL RUMBLE STRIPS SHALL BE MILLED.
 CENTERLINE RUMBLE STRIPS SHALL BE CONTINUOUS THROUGH CONNECTIONS OF SIDEROADS WITH NO LEFT TURN LANES.
 DISCONTINUE CENTERLINE RUMBLE STRIPS THROUGH THE LIMITS OF ALL LEFT TURN LANES, INCLUDING ANY LANE TAPER SECTIONS.

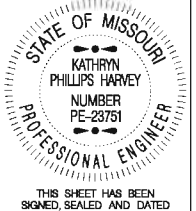
 MISSOURI HIGHWAYS AND TRANSPORTATION COMMISSION 105 WEST CAPITOL JEFFERSON CITY, MO 65102 1-888-ASK-MODOT (1-888-275-6636)	
	RUMBLE STRIPS CENTERLINE
DATE EFFECTIVE: 04/01/2009 DATE PREPARED: 2/20/2009	626.00H
SHEET NO. 2 OF 2	

IF A SEAL IS PRESENT ON THIS SHEET IT HAS BEEN ELECTRONICALLY SEALED AND DATED.