

IF A SEAL IS PRESENT ON THIS SHEET IT HAS BEEN ELECTRONICALLY SEALED AND DATED.

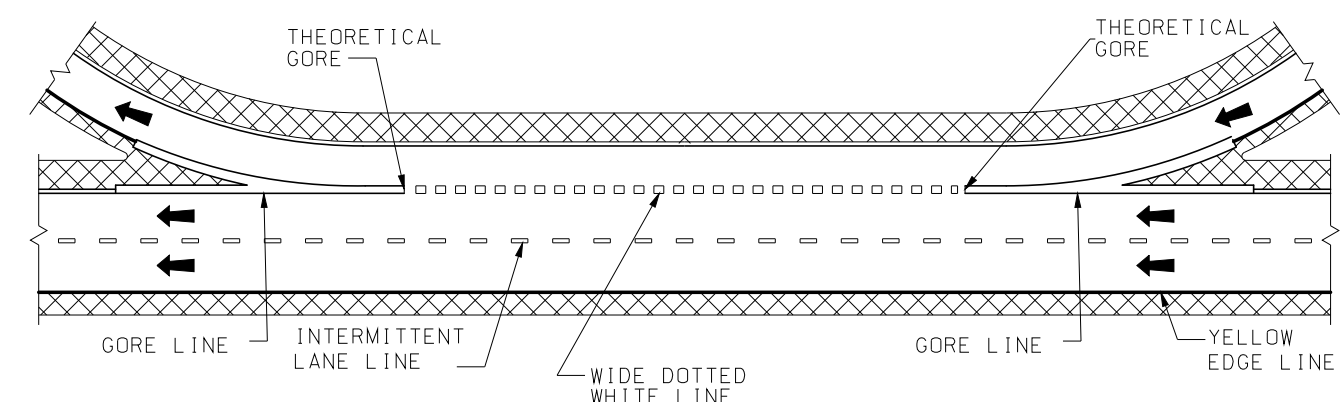

**AUXILIARY LANE MARKING**

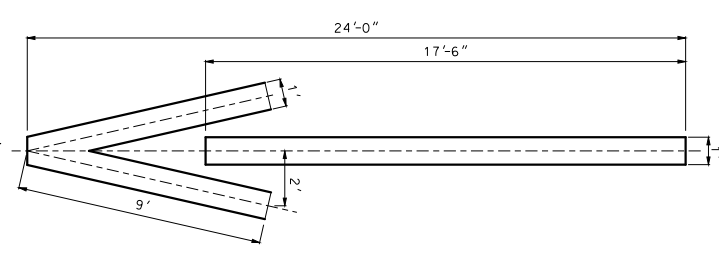
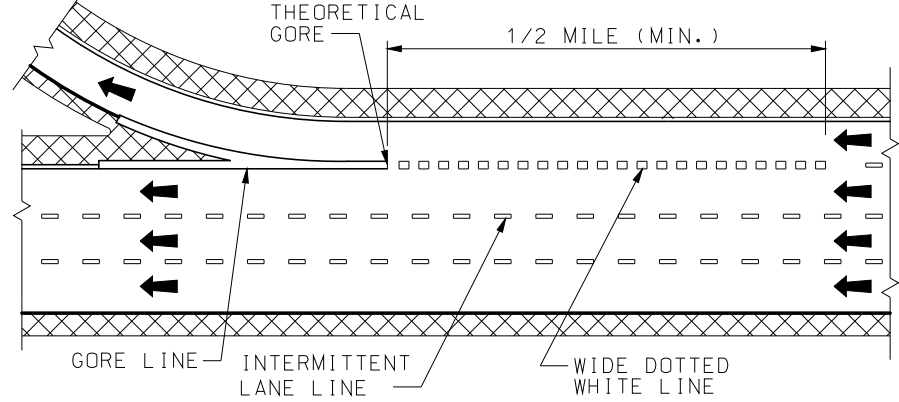

FIRST ARROW 25' FROM CROSSROAD OR STOP LINE.  
 MAXIMUM 3 ARROWS AT 100' INTERVALS.  
 ON MULTI-LANE RAMP USE ARROW IN EACH LANE.  
 WRONG WAY ARROWS ARE NOT USED WHEN RAMP HAS LANE USE CONTROL ARROWS.

**OFF RAMP WRONG WAY ARROW**

**GENERAL NOTES:**

DOTTED LINES SHALL BE 3 FEET IN LENGTH SEPARATED BY 9 FOOT GAPS.  
 REFER TO THE STANDARD PLAN 626.00 WHEN INSTALLING PAVEMENT MARKINGS OVER RUMBLE STRIPS.  
 WIDE LINES ARE TWICE THE WIDTH OF NORMAL LINES.  
 LANE LINES SHALL BE AN INTERMITTENT OR SOLID WHITE.  
 INTERMITTENT LINES SHALL BE 10 FEET IN LENGTH SEPARATED BY 30 FOOT GAPS.

EDGELINES SHALL BE CONTINUOUS SOLID WHITE OR YELLOW LINES. RIGHT SIDE EDGELINES SHALL BE SOLID WHITE. MEDIAN OR LEFT SIDE EDGELINES ON DIVIDED HIGHWAYS AND ON THE LEFT SIDE OF RAMPS SHALL BE SOLID YELLOW. EDGELINES SHALL BE CONTINUOUS ACROSS DRIVEWAYS AND MINOR INTERSECTING ROADS.

"NO PASSING" LINES SHALL BE CONTINUOUS SOLID YELLOW.  
 "NO PASSING" LINES SHALL BE PLACED AS SHOWN IN "LINE DETAIL". "NO PASSING" LINES ON A TWO-LANE, TWO-WAY HIGHWAY WHEN PASSING IS PROHIBITED IN EACH DIRECTION SHALL BE PLACED 4 INCHES APART AND THE INTERMITTENT CENTERLINE SHALL BE OMITTED.

STOP LINES SHALL BE A SOLID WHITE TRANSVERSE LINE 24 INCHES WIDE, LOCATED AT LEAST 4 FEET FROM THE NEAREST EDGE OF THE INTERSECTING ROADWAY.

CROSSWALK LINES SHALL BE SOLID WHITE TRANSVERSE LINES 6 INCHES WIDE AT LEAST 6 FEET APART. CROSSWALK LINES ON THE INTERSECTION SIDE OF THE CROSSWALK SHALL MEET AT THE CURB.

GORE LINES SHALL BE A SOLID WHITE LINE WITH A WIDTH TWICE THAT OF THE EDGELINE.

ARROWS AND WORD SYMBOLS SHALL BE SOLID WHITE.

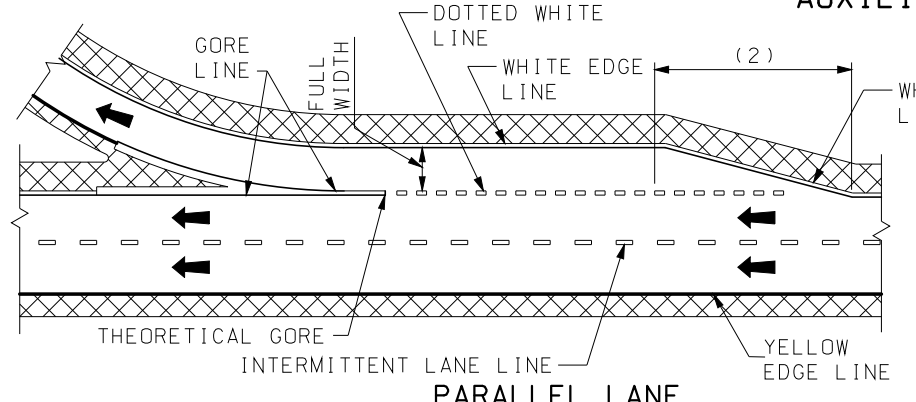

**PARALLEL LANE**

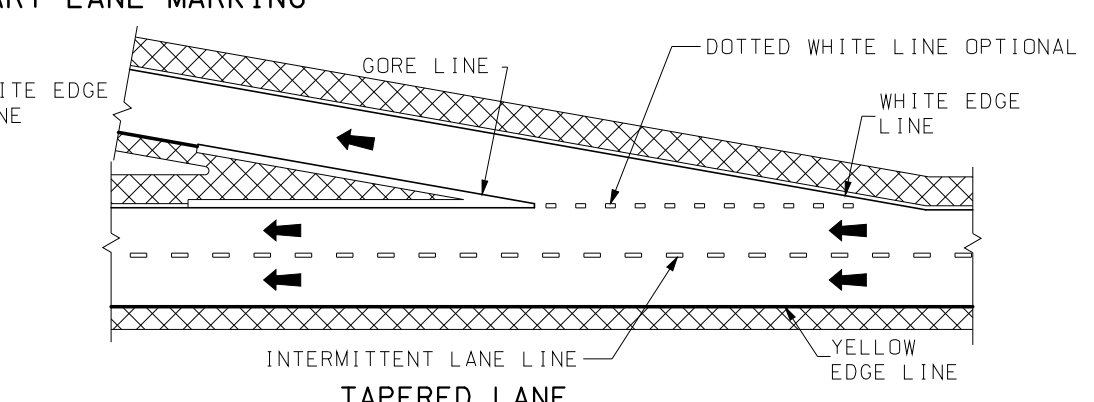

**TAPERED LANE**

**EXIT RAMP MARKING**

A = LENGTH OF ACCELERATION LANE PLUS TAPER.

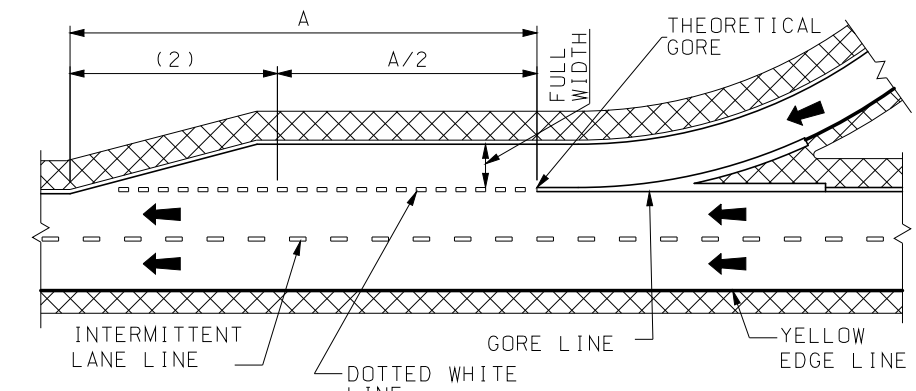

**PARALLEL LANE**

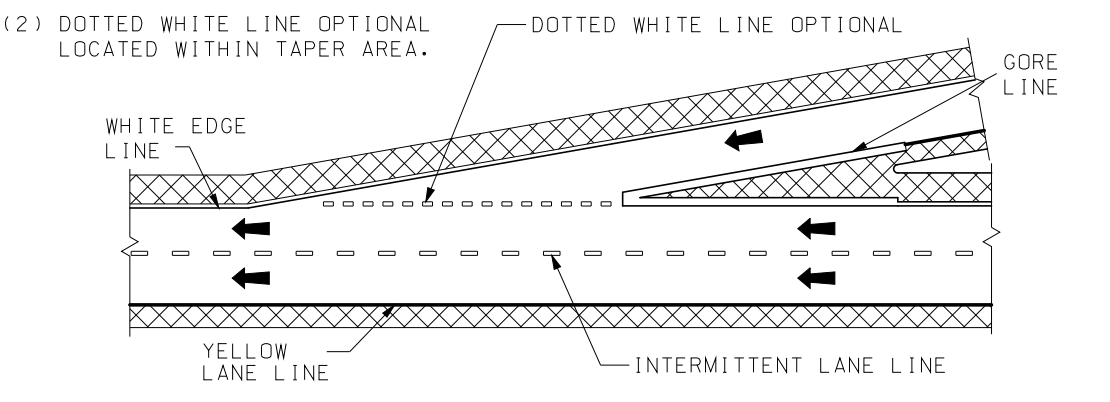

**TAPERED LANE**

**ENTRANCE RAMP MARKING**

(2) DOTTED WHITE LINE OPTIONAL LOCATED WITHIN TAPER AREA.

L = LENGTH OF TAPER IN FEET.

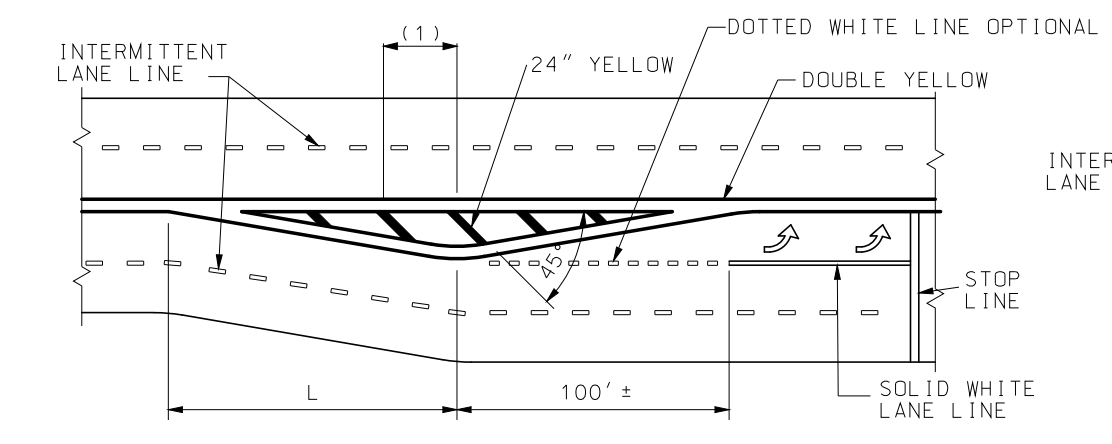

**MEDIAN ISLAND MARKING**

(1) 50' (TYP.) SPACE BETWEEN BARS. A MINIMUM OF 3 BARS ARE REQUIRED. IF NECESSARY, THE DISTANCE BETWEEN THE BARS SHALL BE DECREASED TO INSTALL 3 BARS.

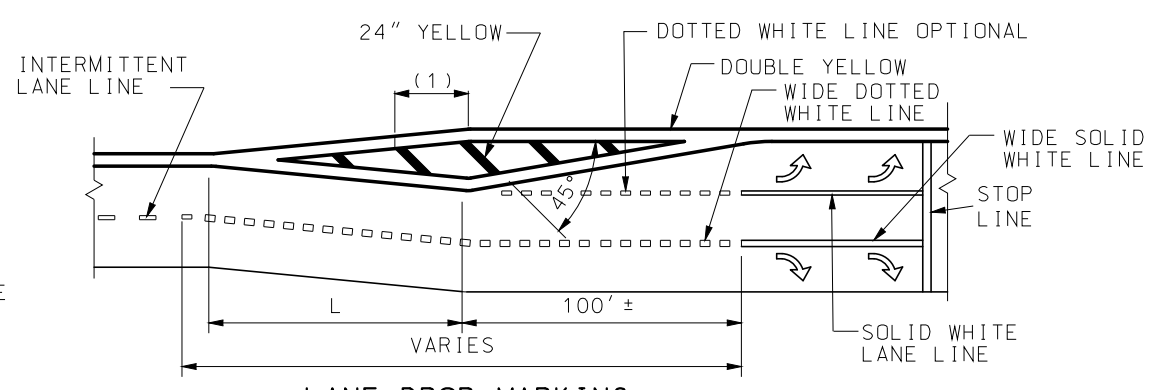

**LANE DROP MARKING**

**MISSOURI HIGHWAYS AND TRANSPORTATION COMMISSION**  
 105 WEST CAPITOL  
 JEFFERSON CITY, MO 65102  
 1-888-ASK-MODOT (1-888-275-6636)

STATE OF MISSOURI  
 ERIC E. SCHROETER  
 NUMBER PE-28411  
 PROFESSIONAL ENGINEER  
 THIS SHEET HAS BEEN SIGNED, SEALED AND DATED ELECTRONICALLY.

DATE EFFECTIVE: 10/01/2016	620.00L	SHEET NO. 1 OF 5
DATE PREPARED: 8/17/2016		

**PAVEMENT MARKING**

IF A SEAL IS PRESENT ON THIS SHEET IT HAS BEEN ELECTRONICALLY SEALED AND DATED.

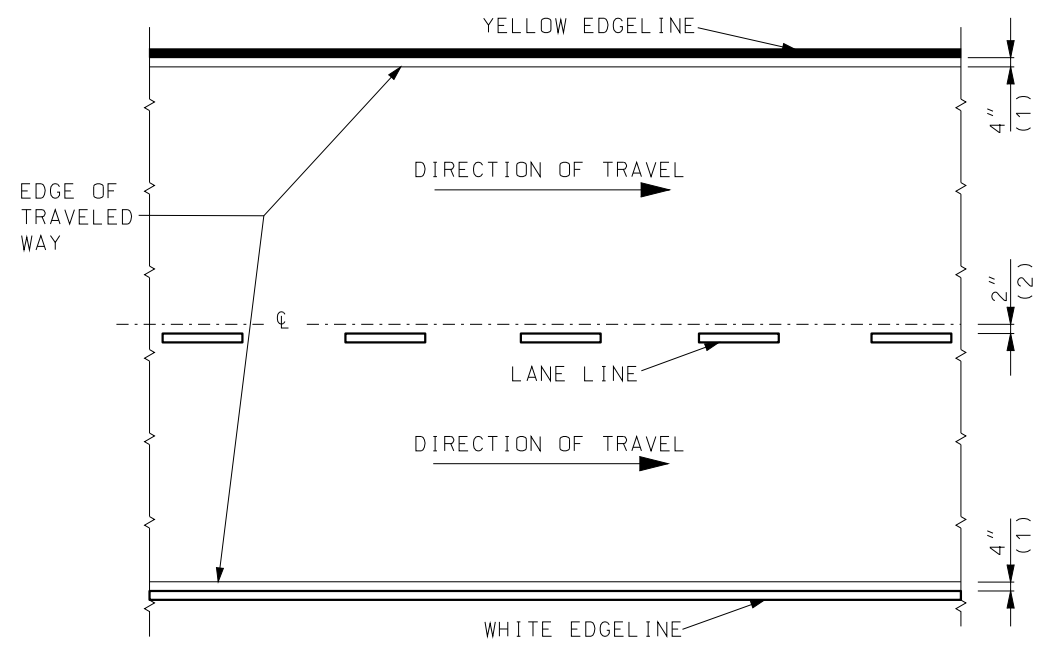

DIVIDED PAVEMENT

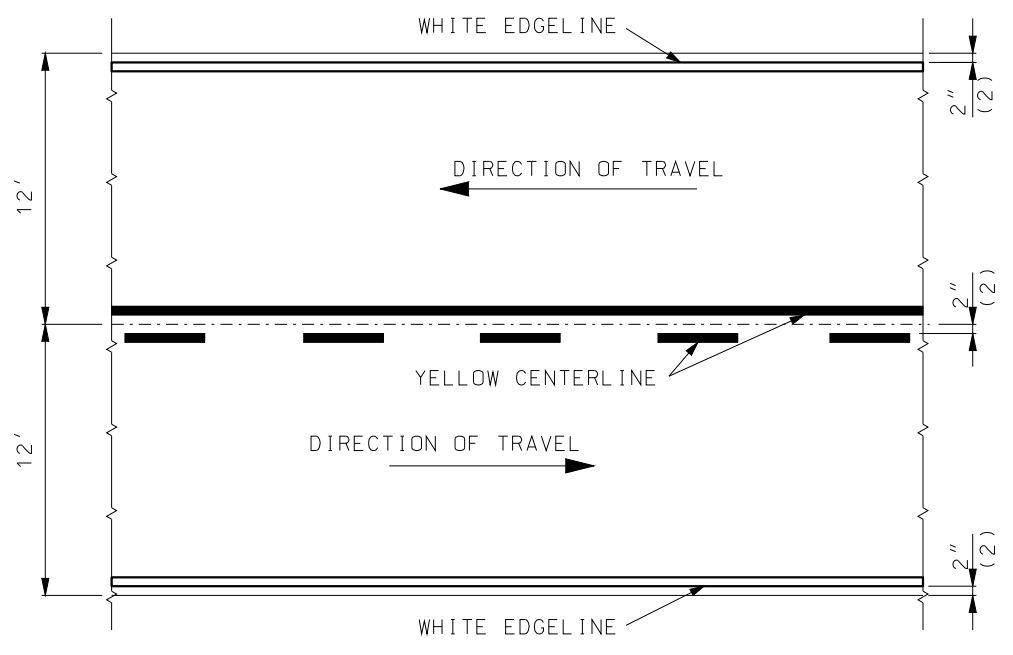

TWO-LANE TWO-WAY  
TYPICAL STRIPING OFFSETS  
WITHOUT RUMBLE STRIPES

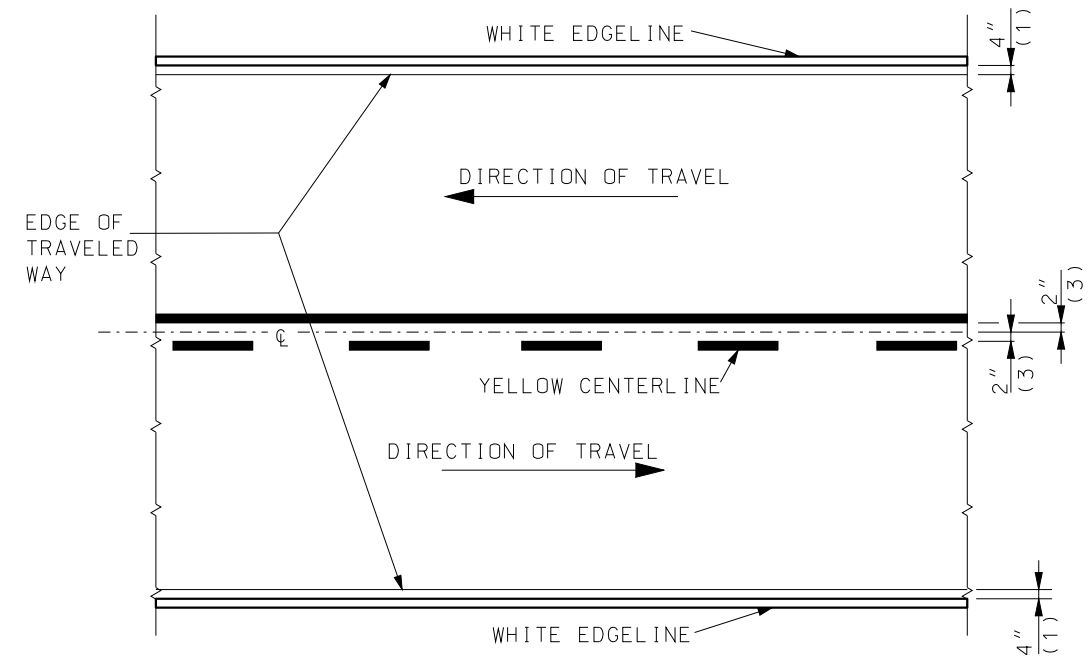

TWO-LANE TWO-WAY  
TYPICAL STRIPING OFFSETS  
FOR RUMBLE STRIPES

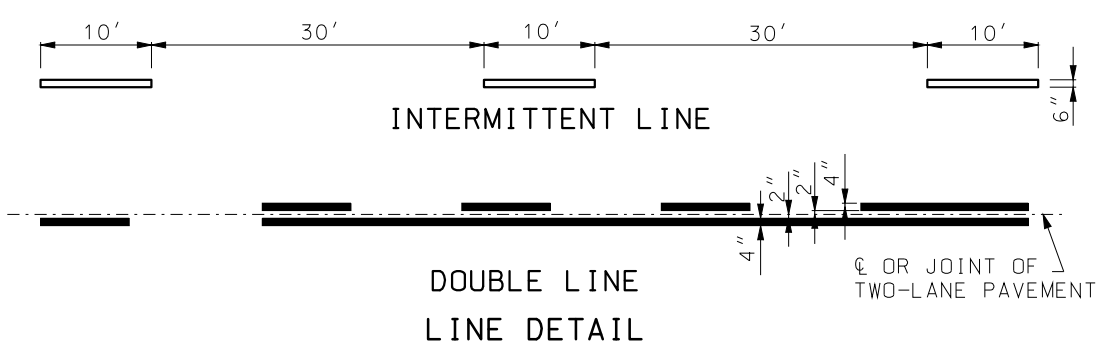

LEGEND  
 WHITE LINE  
 YELLOW LINE

- (1) OFFSET FROM EDGE OF TRAVELED WAY (TYP.)
- (2) OFFSET FROM JOINT (TYP.)
- (3) OFFSET FROM CENTERLINE (TYP.)

**MoDOT** MISSOURI HIGHWAYS AND TRANSPORTATION COMMISSION  
 105 WEST CAPITOL  
 JEFFERSON CITY, MO 65102  
 1-888-ASK-MODOT (1-888-275-6636)

STATE OF MISSOURI  
 ERIC E. SCHROETER  
 NUMBER PE-28411  
 PROFESSIONAL ENGINEER  
 THIS SHEET HAS BEEN SIGNED, SEALED AND DATED ELECTRONICALLY.

PAVEMENT MARKING

DATE EFFECTIVE: 10/01/2016	620.00L	SHEET NO. 2 OF 5
DATE PREPARED: 8/17/2016		

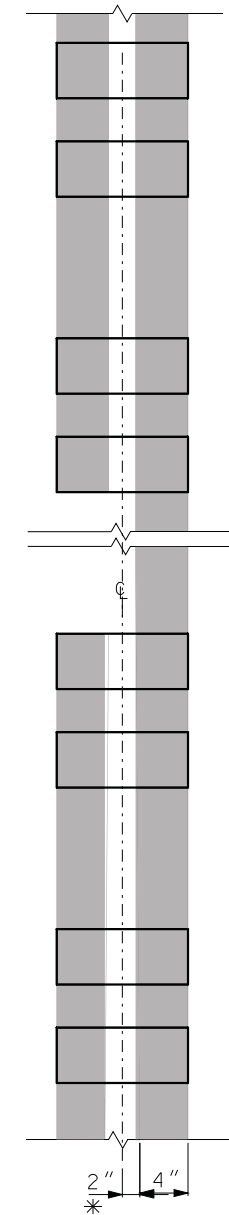
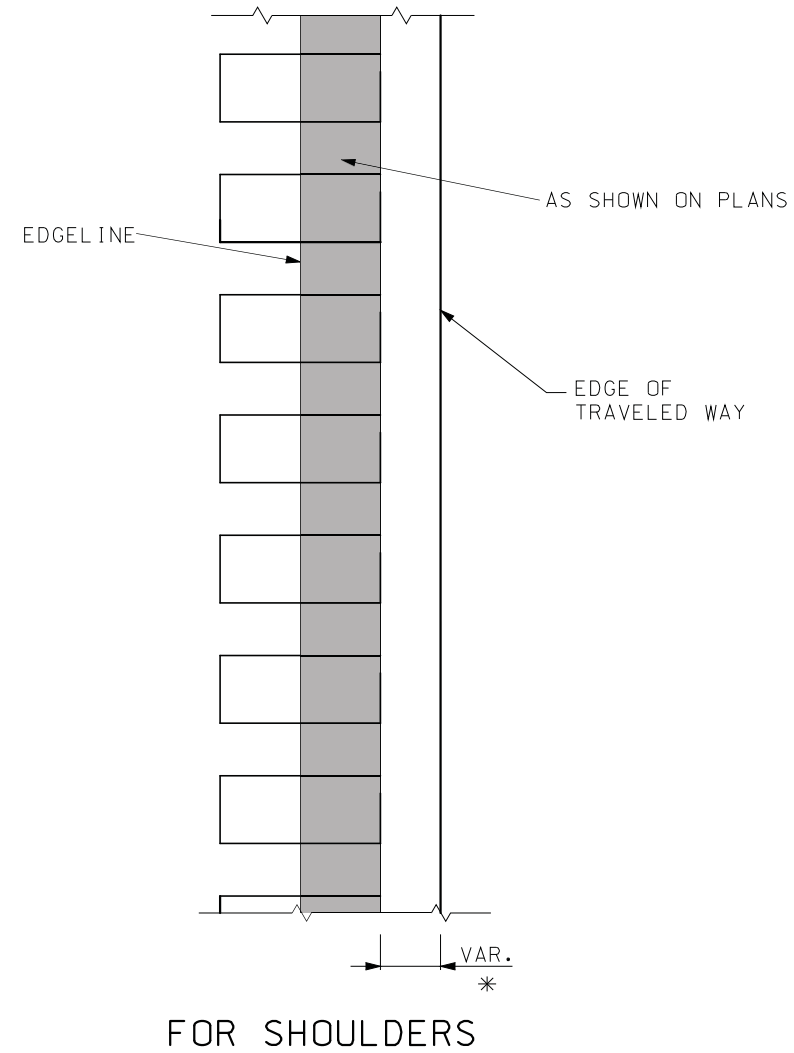

2 WAY 2 LANE  
(SEE TYPICAL STRIPING  
FOR RUMBLESTRIPS)

\* = LATERAL DEVIATION SHALL NOT EXCEED ONE INCH IN 100 FEET.

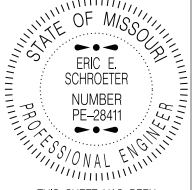
 <b>MISSOURI HIGHWAYS AND TRANSPORTATION COMMISSION</b> 105 WEST CAPITOL JEFFERSON CITY, MO 65102 1-888-ASK-MODOT (1-888-275-6636)	
 <p>STATE OF MISSOURI ERIC E. SCHROETER NUMBER PE-28411 PROFESSIONAL ENGINEER</p> <p>THIS SHEET HAS BEEN SIGNED, SEALED AND DATED ELECTRONICALLY.</p>	<p>PAVEMENT MARKING STRIPING THROUGH RUMBLE STRIPS</p>
DATE EFFECTIVE: 10/01/2016 DATE PREPARED: 8/17/2016	620.00L
SHEET NO. 3 OF 5	

IF A SEAL IS PRESENT ON THIS SHEET IT HAS BEEN ELECTRONICALLY SEALED AND DATED.

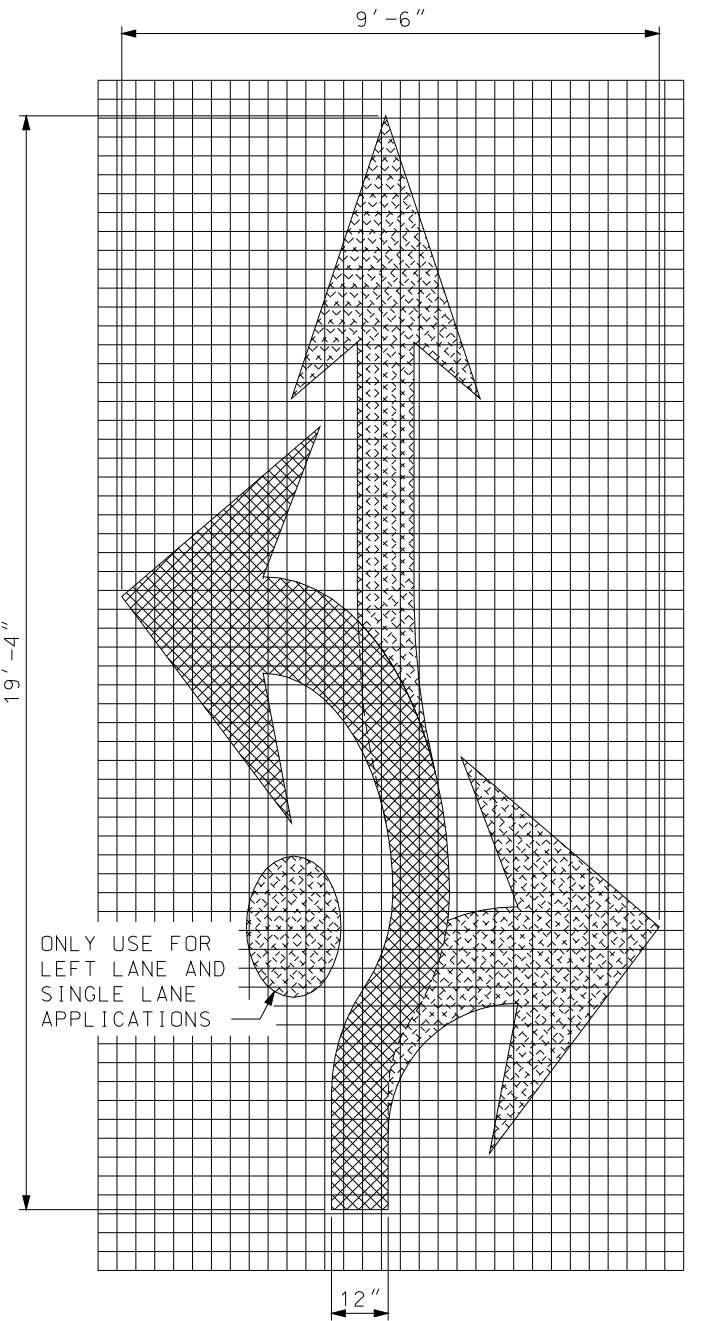
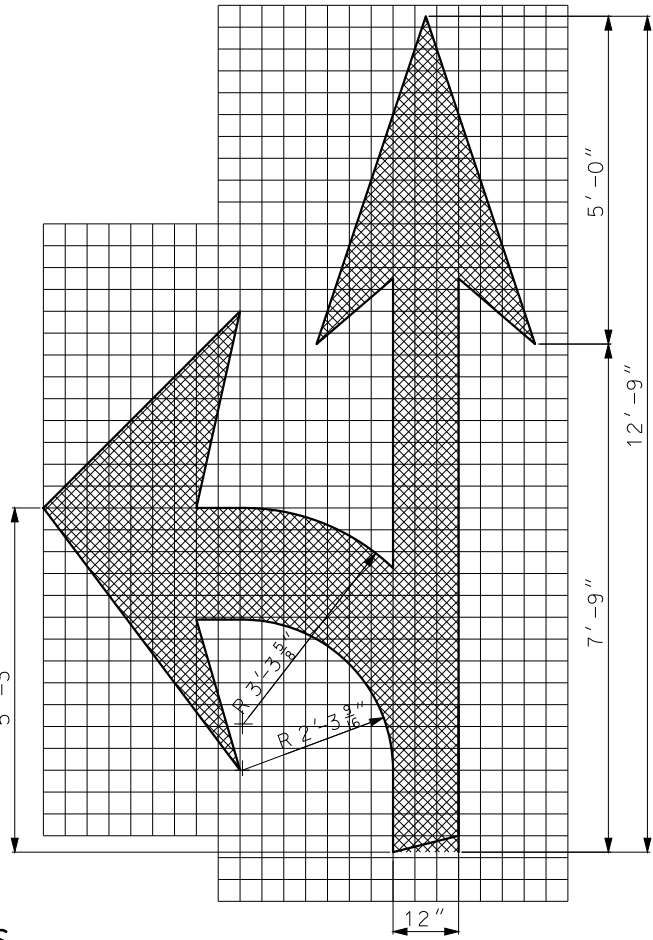
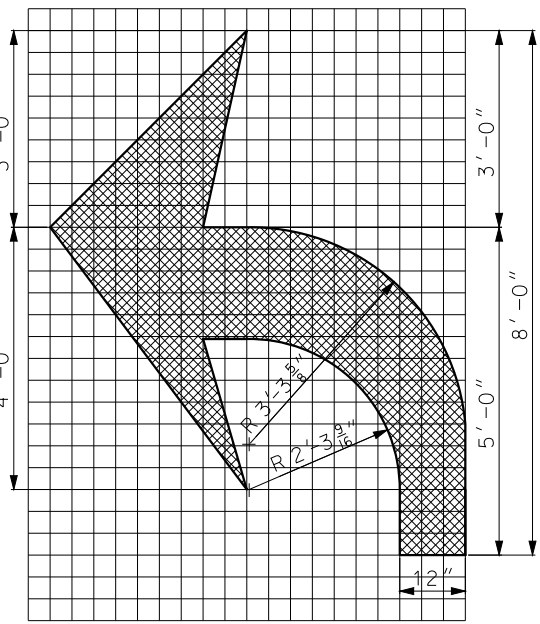
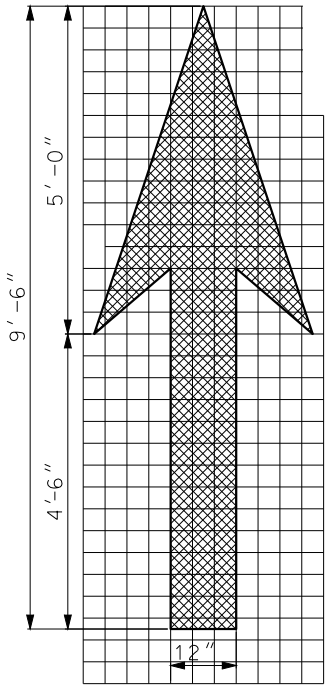
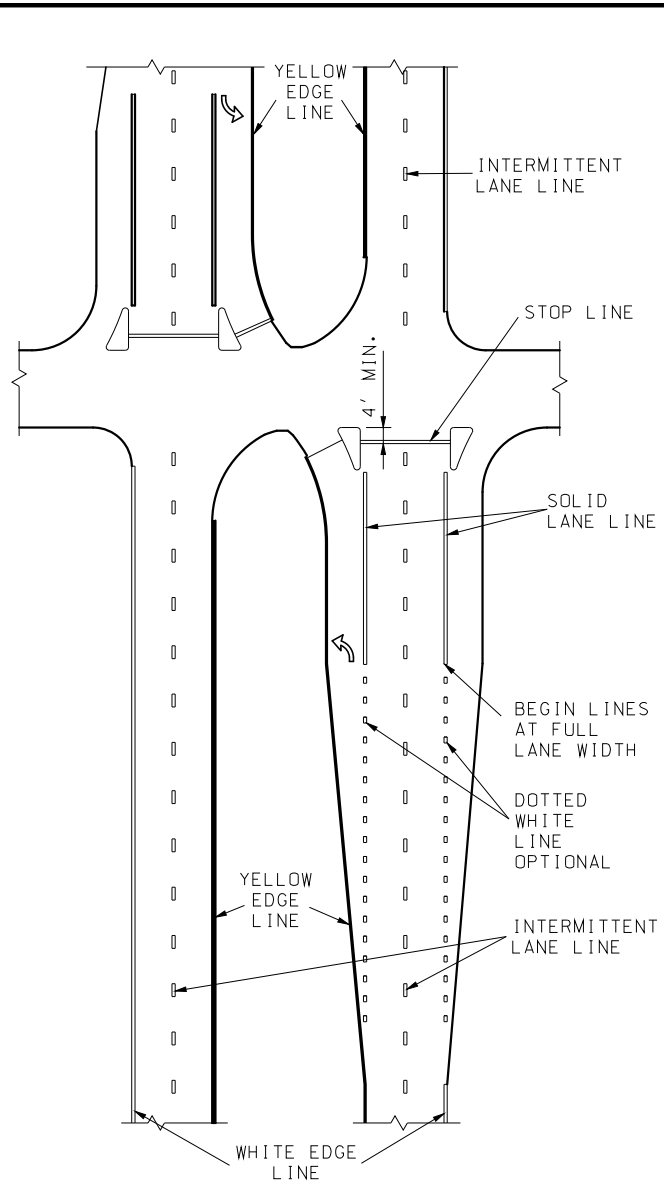

**ARROW MARKINGS**

TWO LANE USE CONTROL ARROWS FOR FIRST 200 FEET WITH ONE ADDITIONAL ARROW EVERY 400 FEET OF MANDATORY MOVEMENT LANE. FIRST ARROW 75 FEET FROM STOP LINE.

**SIGNALIZED GRADE INTERSECTION MARKING**

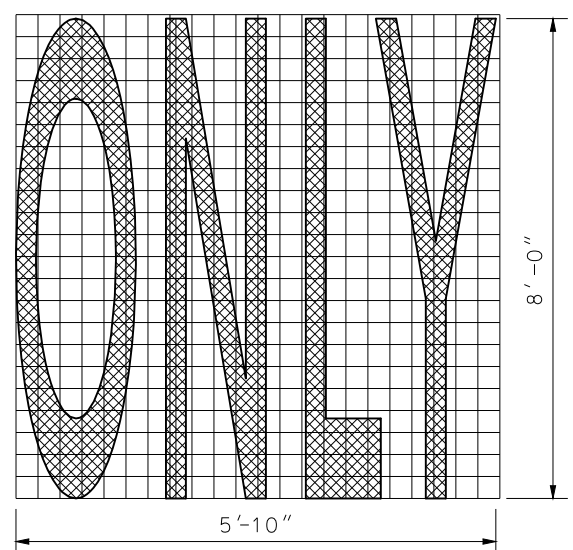

**WORD MARKING  
ELONGATED WORD & SYMBOL**

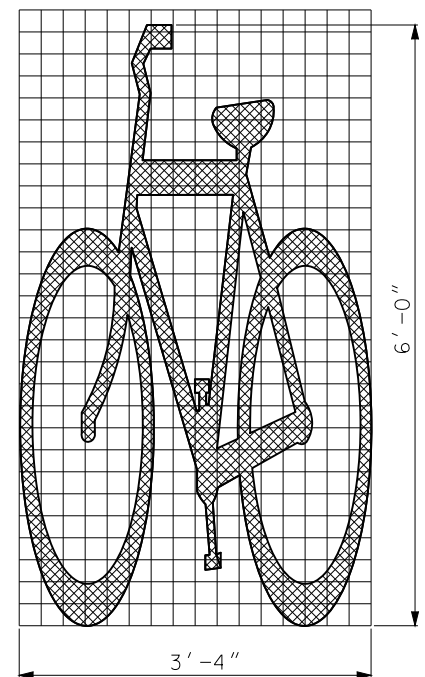

**BICYCLE SYMBOL**

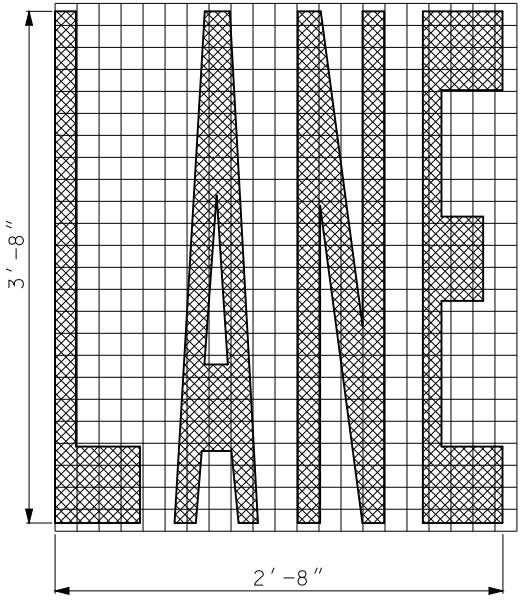

**WORD MARKING  
ELONGATED WORD & SYMBOL**

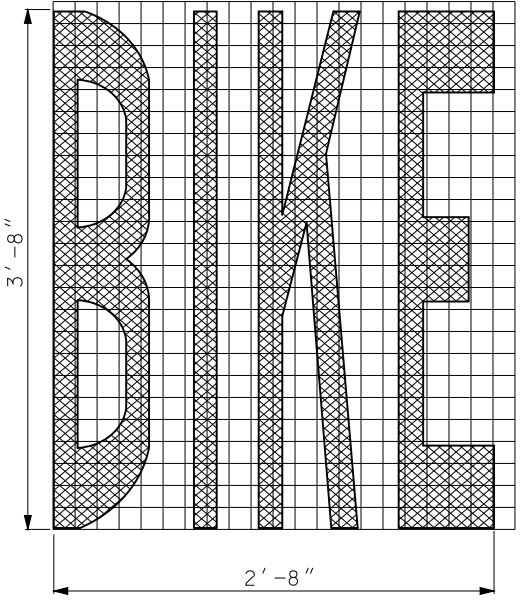

**FISH-HOOK ARROW  
ROUNDBOUT APPROACH  
MARKINGS**

**MoDOT** MISSOURI HIGHWAYS AND TRANSPORTATION COMMISSION  
 105 WEST CAPITOL  
 JEFFERSON CITY, MO 65102  
 1-888-ASK-MODOT (1-888-275-6636)

STATE OF MISSOURI  
 ERIC E. SCHROETER  
 NUMBER PE-28411  
 PROFESSIONAL ENGINEER  
 THIS SHEET HAS BEEN SIGNED, SEALED AND DATED ELECTRONICALLY.

**PAVEMENT MARKING**

DATE EFFECTIVE: 10/01/2016	620.00L	SHEET NO. 4 OF 5
DATE PREPARED: 8/17/2016		

IF A SEAL IS PRESENT ON THIS SHEET IT HAS BEEN ELECTRONICALLY SEALED AND DATED.

1. STOP LINES SHALL BE PLACED 90° TO THE ROADWAY.
2. IF RAILROAD GATE IS PRESENT THE STOP LINE SHALL BE 8' FROM GATE.

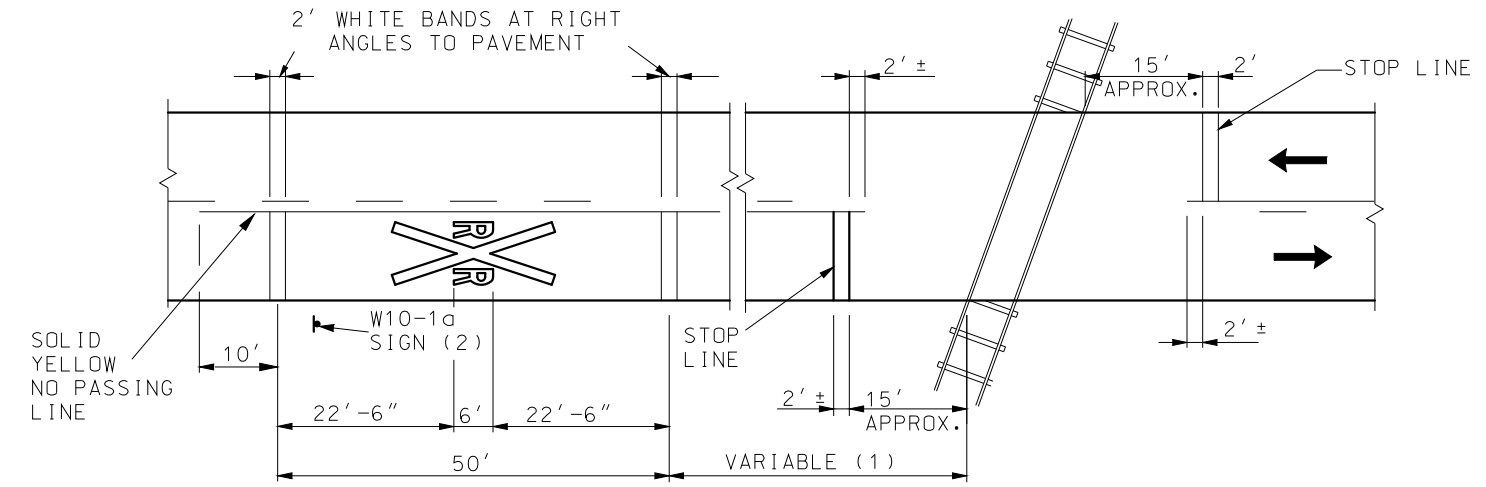

PAVEMENT DETAIL

- (1) THE DISTANCE FROM THE RAILROAD CROSSING MARKING TO THE NEAREST TRACK WILL VARY ACCORDING TO THE APPROACH SPEED AND THE SIGHT DISTANCE OF THE VEHICULAR TRAFFIC APPROACHING, BUT SHALL BE NO LESS THAN 50 FEET. A THREE-LANE ROADWAY SHALL BE MARKED WITH A CENTERLINE FOR TWO-LANE APPROACH OPERATION ON THE APPROACH TO A CROSSING. ON MULTI-LANE ROADWAYS THE TRANSVERSE BANDS SHALL EXTEND ACROSS ALL APPROACH LANES, AND INDIVIDUAL "R X R" SYMBOLS SHALL BE USED IN EACH APPROACH LANE.
- (2) PLACEMENT OF W10-1a SIGN BY OTHERS.

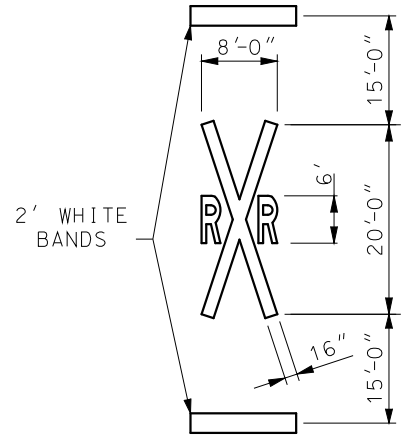

SYMBOL DETAIL

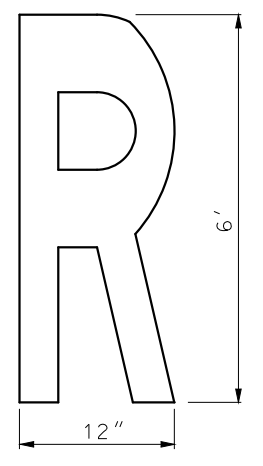

LETTER DETAIL

RAILROAD GRADE CROSSING

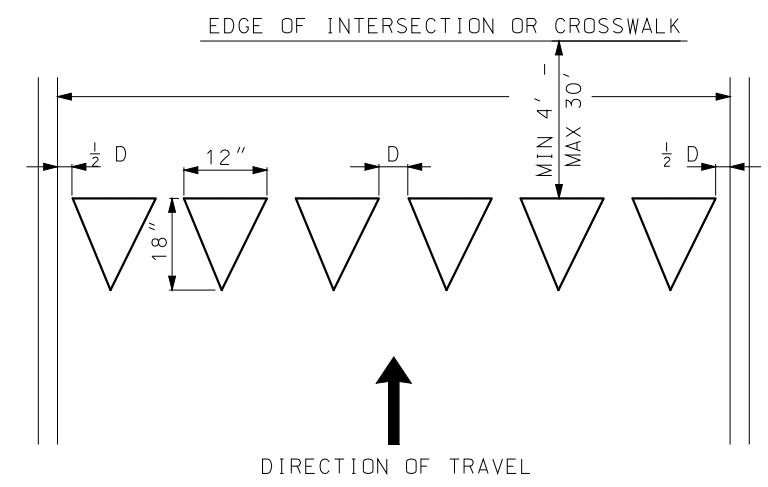

WHITE YIELD LINE TRIANGLES

$D = 3''$  TO  $12''$

TRIANGLES SHALL BE UNIFORMLY SPACED AND COVER THE COMPLETE WIDTH OF THE TRAVEL LANE. SPACING SHALL BE ADJUSTED SO THERE ARE NO PARTIAL TRIANGLES WITHIN THE YIELD MARKING.

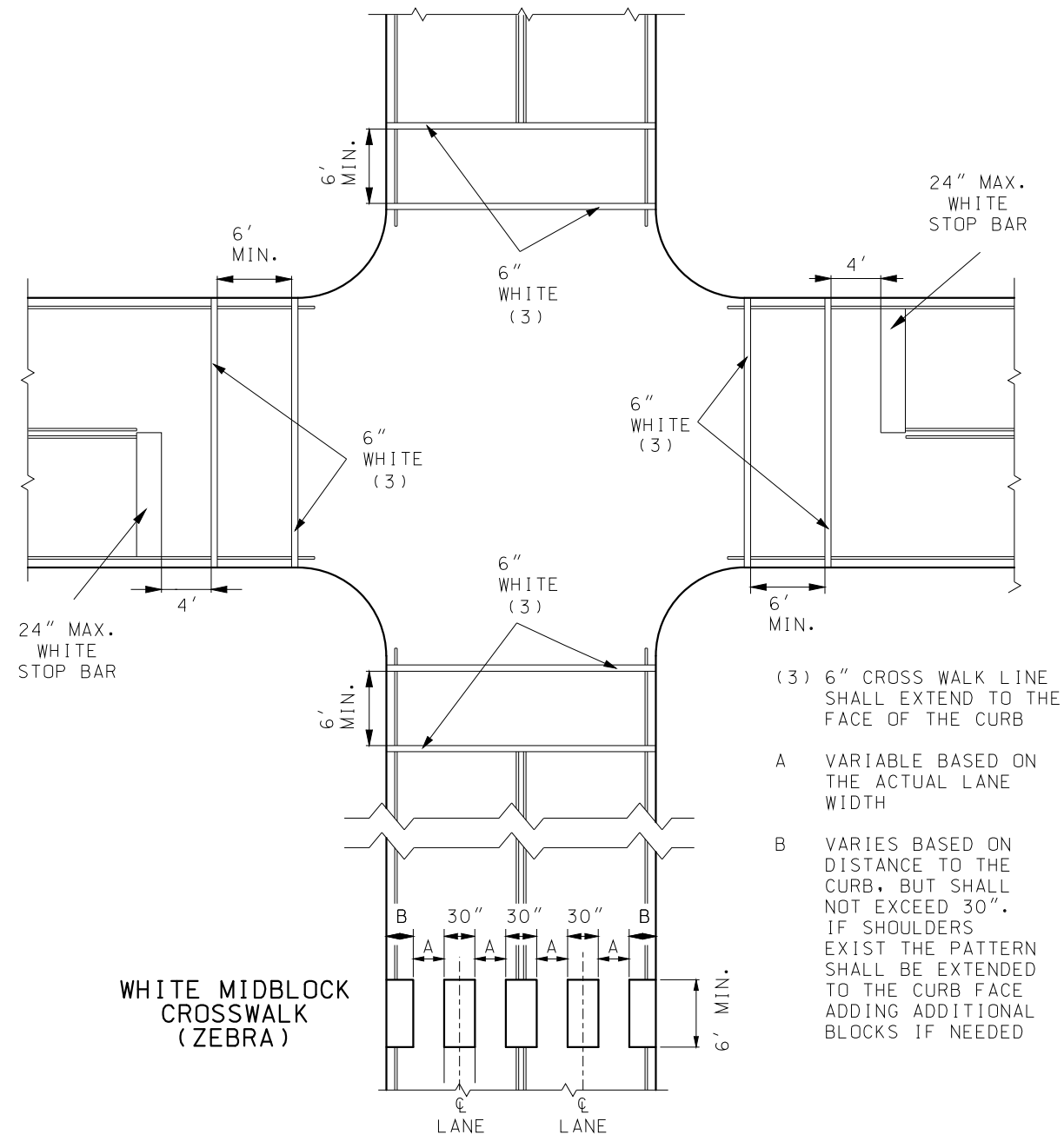

PEDESTRIAN CROSSWALKS

**MoDOT MISSOURI HIGHWAYS AND TRANSPORTATION COMMISSION**  
 105 WEST CAPITOL JEFFERSON CITY, MO 65102  
 1-888-ASK-MODOT (1-888-275-6636)

STATE OF MISSOURI  
 ERIC E. SCHROETER  
 NUMBER PE-28411  
 PROFESSIONAL ENGINEER

PAVEMENT MARKING

DATE EFFECTIVE: 10/01/2016	620.00L	SHEET NO. 5 OF 5
DATE PREPARED: 8/17/2016		

IF A SEAL IS PRESENT ON THIS SHEET IT HAS BEEN ELECTRONICALLY SEALED AND DATED.