

IF A SEAL IS PRESENT ON THIS SHEET IT HAS BEEN ELECTRONICALLY SEALED AND DATED.

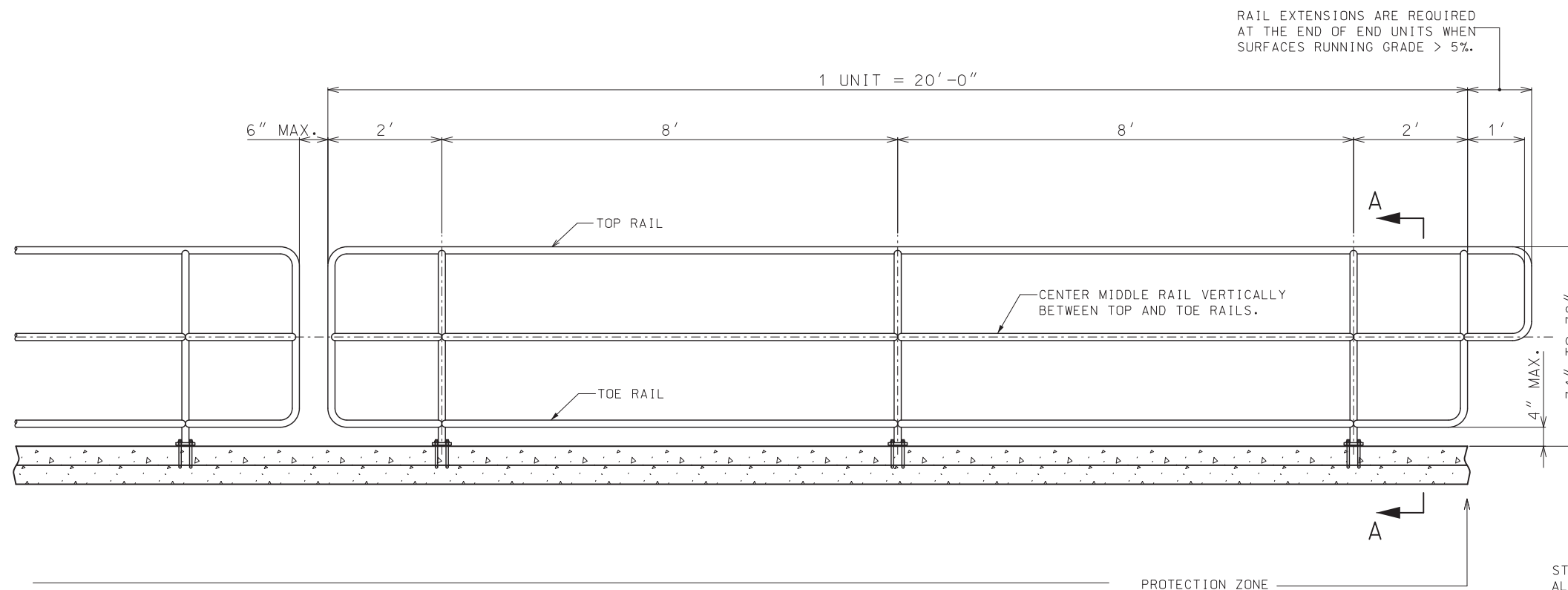

### SIDEWALK HANDRAILING WITHOUT BALUSTERS

\* CROSS SLOPE: 1.0 % MIN. - 2.0 % MAX.

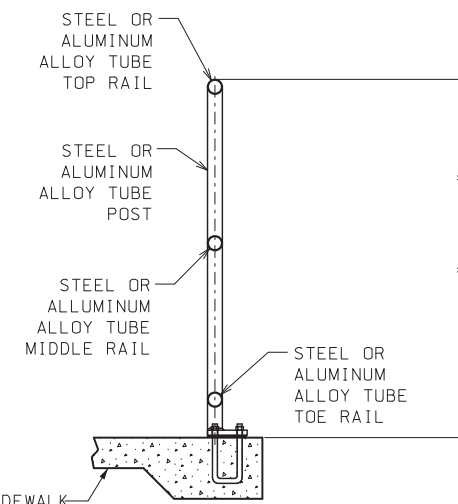

HANDRAILING

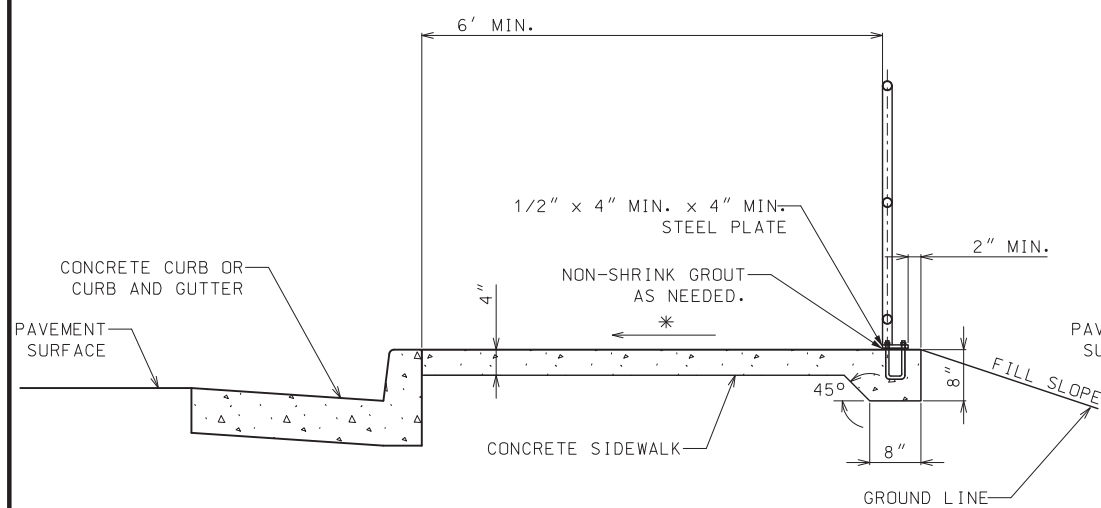

SIDEWALK WITHOUT BUFFER STRIP (SECTION A-A)

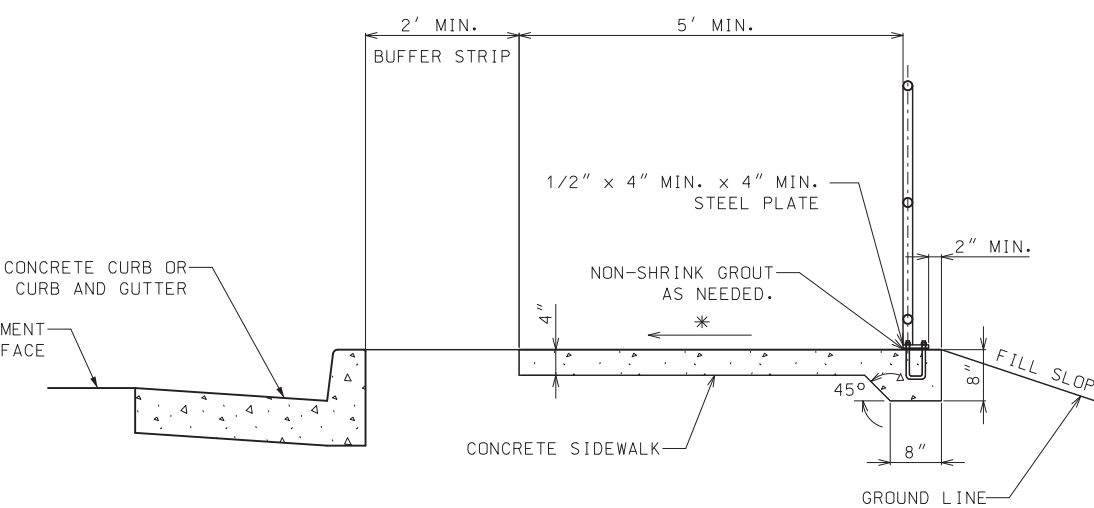

SIDEWALK WITH BUFFER STRIP (SECTION A-A)

FOR GENERAL NOTES AND HANDRAILING REQUIREMENTS ON FILL SLOPES SEE SHEET 3 OF 4

<p><b>MISSOURI HIGHWAYS AND TRANSPORTATION COMMISSION</b></p> <p>105 WEST CAPITOL JEFFERSON CITY, MO 65102 1-888-ASK-MODOT (1-888-275-6636)</p>	
	<p><b>HANDRAILING</b></p>
<p>DATE EFFECTIVE: 07/01/2018</p> <p>DATE PREPARED: 5/3/2018</p>	<p>608.40</p>
<p>SHEET NO. 1 OF 4</p>	

IF A SEAL IS PRESENT ON THIS SHEET IT HAS BEEN ELECTRONICALLY SEALED AND DATED.

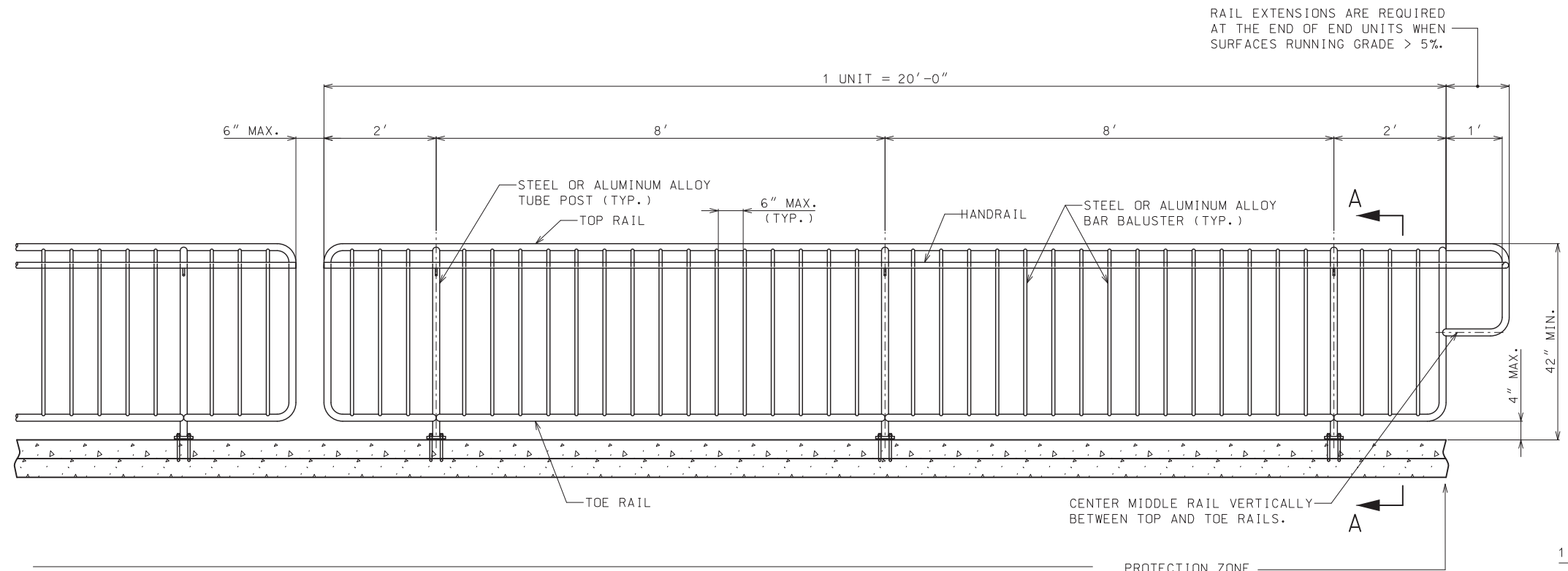

RAIL EXTENSIONS ARE REQUIRED AT THE END OF END UNITS WHEN SURFACES RUNNING GRADE > 5%.

1 UNIT = 20'-0"

**SIDEWALK SAFETY RAIL WITH BALUSTERS AND HANDRAIL**

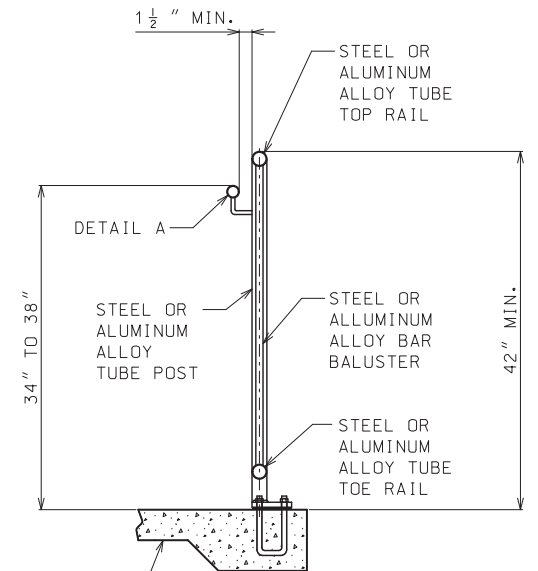

**SAFETY RAIL WITH HANDRAIL**

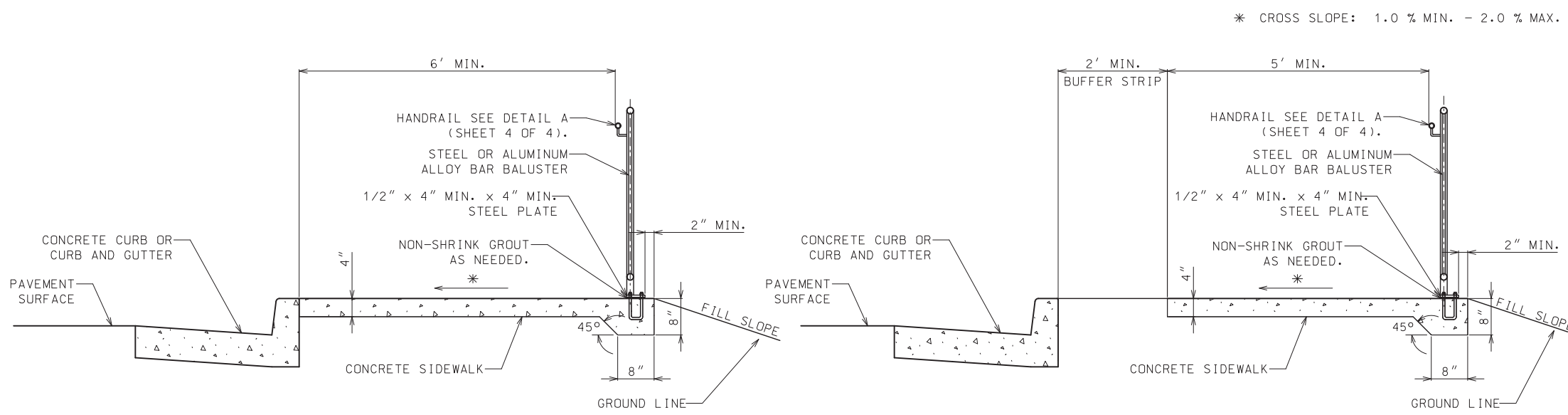

**SIDEWALK WITHOUT BUFFER STRIP (SECTION A-A)**

**SIDEWALK WITH BUFFER STRIP (SECTION A-A)**

FOR GENERAL NOTES AND HANDRAIL REQUIREMENTS ON FILL SLOPES SEE SHEET 3 OF 4.

<p><b>MISSOURI HIGHWAYS AND TRANSPORTATION COMMISSION</b></p> <p>105 WEST CAPITOL JEFFERSON CITY, MO 65102 1-888-ASK-MODOT (1-888-275-6636)</p>	
	<p><b>HANDRAILING</b></p>
<p>DATE EFFECTIVE: 07/01/2018 DATE PREPARED: 5/3/2018</p>	<p><b>608.40</b></p> <p>SHEET NO. 2 OF 4</p>

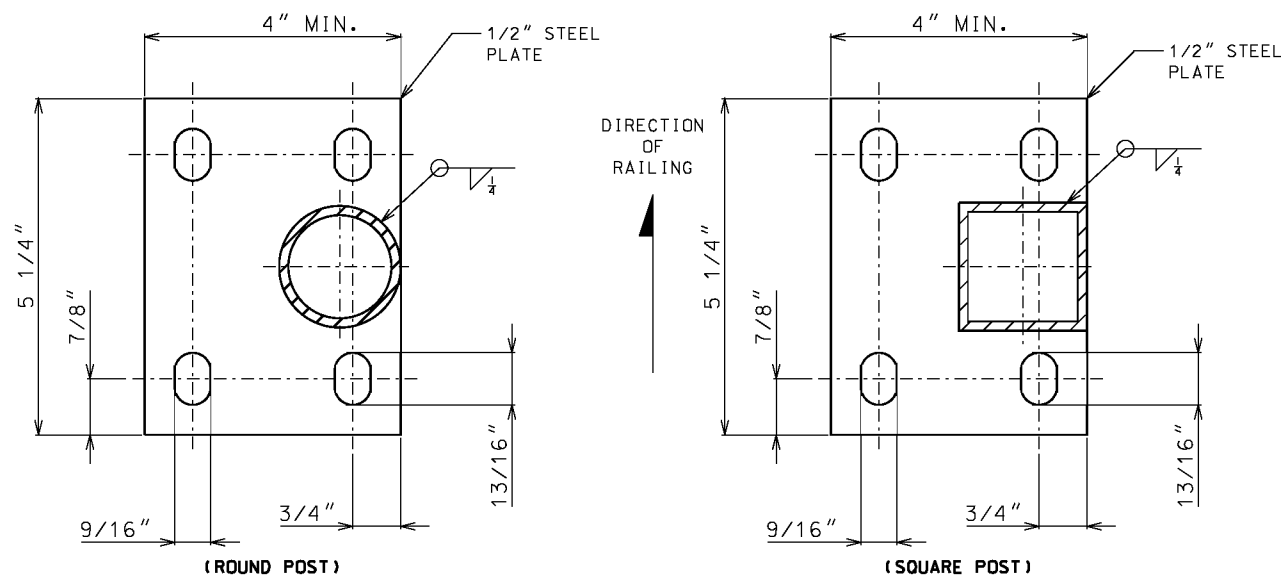

**MOUNTING PLATE DETAIL  
(PLAN VIEW)**

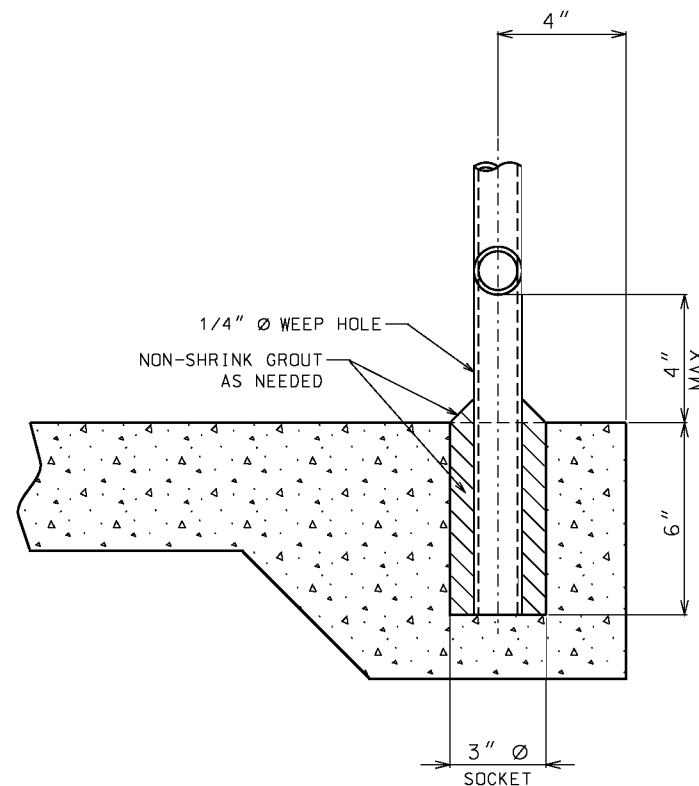

**SOCKET MOUNTING DETAIL**

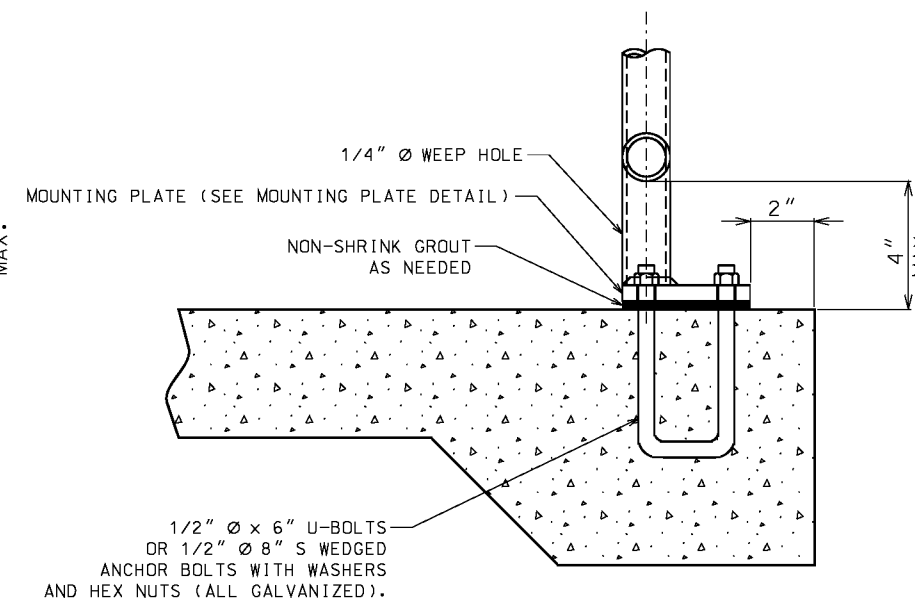

**PLATE MOUNTING DETAIL**

**GENERAL NOTES:**

RAILINGS AND POSTS MAY BE EITHER ROUND OR SQUARE STEEL OF GOOD COMMERCIAL WELDABLE QUALITY OR ALUMINUM ALLOY 6061-T6 OR 6063-T6.

STEEL RAILINGS AND POSTS SHALL BE GALVANIZED AFTER FABRICATION IN ACCORDANCE WITH AASHTO M111.

ALL JOINTS SHALL BE CONTINUOUS WELDED AND GROUND SMOOTH.

METAL SAFETY RAIL MUST BE COMPLIANT WITH THE "AMERICAN'S WITH DISABILITIES ACT ACCESSIBILITY GUIDELINES (ADAAG)". EXCEPTIONS MUST BE APPROVED BY THE ENGINEER. ALL OTHER AREAS OF NON-COMPLIANCE SHALL BE REMOVED AND CORRECTED AT THE CONTRACTOR'S EXPENSE.

ALL POSTS SHALL HAVE A 1/4" WEEP HOLE IMMEDIATELY ABOVE THE MOUNTING PLATE.

WHEN INSTALLED THE POSTS SHALL BE PLUMB AND RAILINGS SHALL MATCH THE SLOPE OF THE SIDEWALK.

HANDRAIL REQUIREMENTS		
FILL SLOPE	FILL HEIGHT	HANDRAIL
(1V:3H) OR FLATTER	—	NOT REQUIRED
(1V:3H) OR STEEPER	≥ 6 FT.	REQUIRED
(1V:2H) OR STEEPER	≥ 4 FT.	REQUIRED
(1V:1H) OR STEEPER	≥ 1 FT.	REQUIRED

RAILING AND POST SPECIFICATION				
DESCRIPTION	TYPE	SIZE ( DIA. )	WEIGHT (LBS. / FT.)	
			ALUM.	STEEL
RAILING & POST	ROUND	1 1/2"	0.940	2.720
	SQUARE	2" X 2"	1.3094	4.310
BALUSTER	ROUND	1/2"	0.2312	0.668
	RECT.	3/8" X 1/2" STL.	—	0.6375
	SQUARE	1/2" X 1/2" ALUM.	0.2944	—

**MISSOURI HIGHWAYS AND TRANSPORTATION COMMISSION**

105 WEST CAPITOL  
JEFFERSON CITY, MO 65102  
1-888-ASK-MODOT (1-888-275-6636)

**HANDRAILING**

THIS SHEET HAS BEEN SIGNED, SEALED AND DATED ELECTRONICALLY.

DATE EFFECTIVE: 04/01/2015

DATE PREPARED: 2/20/2015

**608.40**

SHEET NO.  
**3 OF 4**

IF A SEAL IS PRESENT ON THIS SHEET IT HAS BEEN ELECTRONICALLY SEALED AND DATED.

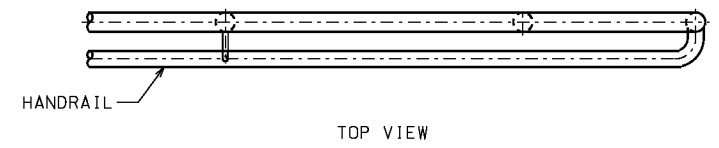

TOP VIEW

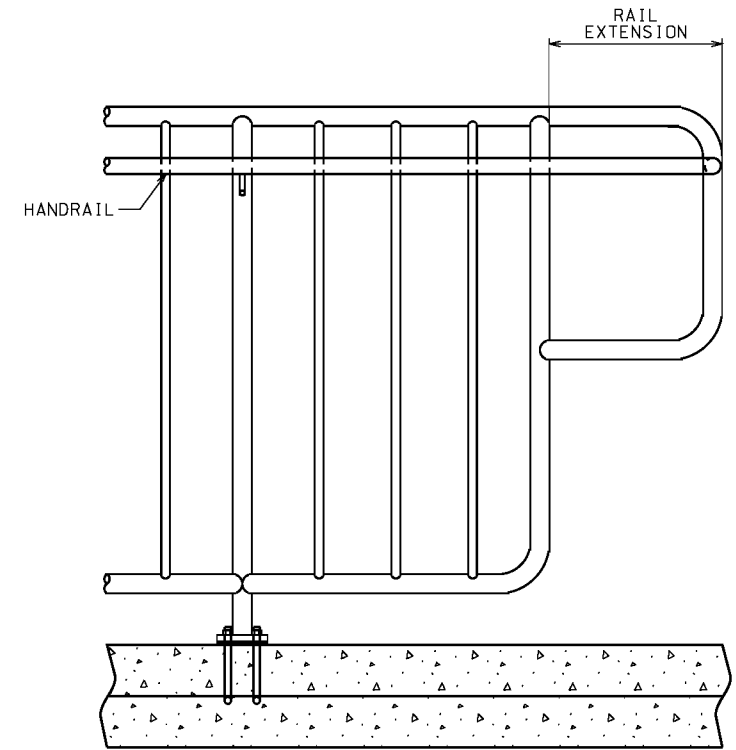

FRONT VIEW

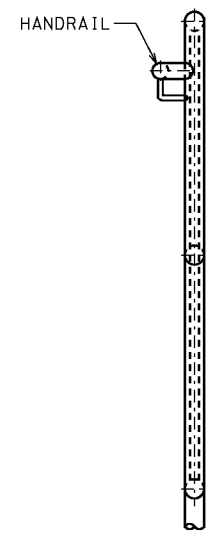

END VIEW

HANDRAIL AND EXTENSION CONNECTION

**DETAIL A - HANDRAIL**

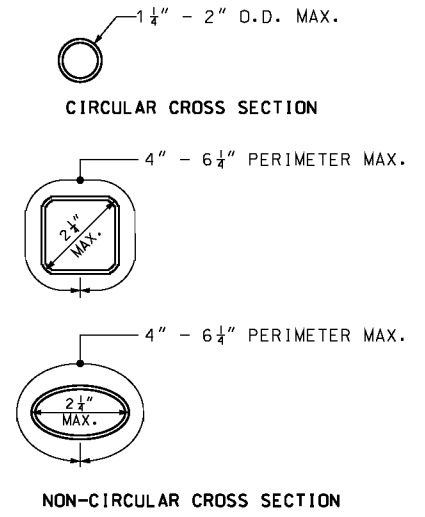

HANDRAIL GRIPPING SURFACES

**HANDRAIL NOTES:**

HANDRAILS SHALL BE STEEL OF GOOD COMMERCIAL WELDABLE QUALITY OR ALUMINUM ALLOY 6061-T6 OR 6063-T6.

HANDRAILS SHALL BE GALVANIZED AFTER FABRICATION IN ACCORDANCE WITH AASHTO M111.

HANDRAILS SHALL BE AT A CONSISTENT HEIGHT ABOVE WALKING SURFACES.

HANDRAIL GRIPPING SURFACES SHALL BE CONTINUOUS ALONG THEIR LENGTH AND SHALL NOT BE OBSTRUCTED ALONG THEIR TOPS OR SIDES.

THE BOTTOMS OF HANDRAIL GRIPPING SURFACES SHALL NOT BE OBSTRUCTED FOR MORE THAN 20 PERCENT OF THEIR LENGTH.

WHERE HANDRAILS ARE PROVIDED ALONG WALKING SURFACES WITH SLOPES NOT STEEPER THAN 1:20, THE BOTTOMS OF HANDRAIL GRIPPING SURFACES SHALL BE PERMITTED TO BE OBSTRUCTED ALONG THEIR ENTIRE LENGTH WHERE THEY ARE INTEGRAL TO CRASH RAILS OR BUMPER GUARDS.

THE DISTANCE BETWEEN HORIZONTAL PROJECTIONS AND THE BOTTOM OF THE GRIPPING SURFACE SHALL BE PERMITTED TO BE REDUCED BY  $\frac{1}{8}$ " FOR EACH  $\frac{1}{2}$ " OF ADDITIONAL HANDRAIL PERIMETER DIMENSION THAT EXCEEDS 4".

HANDRAIL SURFACES AND ANY SURFACES ADJACENT TO THEM SHALL BE FREE OF SHARP OR ABRASIVE ELEMENTS AND SHALL HAVE ROUNDED EDGES.

HANDRAILS SHALL NOT ROTATE WITHIN THEIR FITTINGS.

	<b>MISSOURI HIGHWAYS AND TRANSPORTATION COMMISSION</b> 105 WEST CAPITOL JEFFERSON CITY, MO 65102 1-888-ASK-MODOT (1-888-275-6636)	
		<p align="center"><b>HANDRAILING</b></p>
DATE EFFECTIVE: 04/01/2015 DATE PREPARED: 2/20/2015	<p align="center"><b>608.40</b></p>	SHEET NO. 4 OF 4

IF A SEAL IS PRESENT ON THIS SHEET IT HAS BEEN ELECTRONICALLY SEALED AND DATED.