



---

# Engineering Policy Ballot

Effective: October 1, 2026

## Level 2

Level two revisions require the approval of the **Assistant Chief Engineer** and the **Federal Highway Administration** only. The Senior Management Team is encouraged to review the content and provide comment to the appropriate director. For all other parties, these revisions are posted for information only.

---

# ENGINEERING POLICY BALLOT

**Effective:** October 1, 2026

## **Issue 1: Incorporating Balanced Mix Design (BMD) Into Sec 403**

**Approval:** Level 2 – Assistant Chief Engineer

**Sponsor:** Jason Blomberg – CM

**Summary:** Combines Sec 403 specification and JSP2401 - Balanced Mix Design Requirements into one specification in the Standard Specifications. In addition, Sec 406 is created for Paver Mounted Thermal Profile and a new MoDOT-TM100 test method to be incorporated.

**Publication:** Missouri Standard Specifications: 403, 406  
Engineering Policy Guide: 106.3.2-Test Method 100 (new)

## **Issue 2: Clarification On Curing In Section 501.4**

**Approval:** Level 2 – Assistant Chief Engineer

**Sponsor:** Brett Trautman – CM

**Summary:** Provides additional details regarding standard curing for mix design and approvals and field curing for assessing construction activities.

**Publication:** Missouri Standard Specifications: 501.4

## **Issue 3: Marred Surface Deductions**

**Approval:** Level 2 – Assistant Chief Engineer

**Sponsor:** Colten Johnson – CM

**Summary:** Clarifying intent for deduct to apply to surface and sub-courses for asphalt pavements.

**Publication:** Missouri Standard Specifications: 610.5.3

## **Issue 4: Polyphosphoric Acid (PPA) Limit For Asphalt Binder In Sec 1015**

**Approval:** Level 2 – Assistant Chief Engineer

**Sponsor:** Jason Blomberg – CM

**Summary:** The proposed change limits the amount of PPA in asphalt binders for Sec 401,402, and 403 asphalt mixtures.

**Publication:** Missouri Standard Specifications: 1015

## **Issue 5: Precast Concrete Box Culvert Split-box Design (Longitudinal Joint)**

**Approval:** Level 2 – Assistant Chief Engineer

**Sponsor:** Darren Kemna – BR

**Summary:** Clarifying special design requirements for precast box culverts. Precast split-box designs in accordance with ASTM C1786 with or without modification are not an acceptable precast alternative for special designs.

**Publication:** Missouri Standard Specifications: 1049  
Engineering Policy Guide: 751.8.1.5, 1049.2

## **Issue 6: Driveway Type I Requirement Modifications**

**Approval:** Level 2 – Assistant Chief Engineer

**Sponsor:** Kataryna Garlock – TR

**Summary:** Adding Agricultural Driveway Category and right-turn radii details.

**Publication:** Missouri Standard Plans: 203.61  
Engineering Policy Guide: 940.16

## **Issue 7: Concrete Roundabout Joint Layout**

**Approval:** Level 2 – Assistant Chief Engineer

**Sponsor:** Jason Blomberg – CM

**Summary:** New standard plan for concrete roundabouts to serve as starting point of joint layout.

**Publication:** Missouri Standard Plans: 502.06

## **Issue 8: Updating TM-93 To Reflect Current Process For Approval Of Concrete Aggregate.**

**Approval:** Level 2 – Assistant Chief Engineer

**Sponsor:** Lori Greer – CM

**Summary:** Updated EPG charts to show current process of approving concrete aggregate. The change allows for provisional approval based on physical test results until the 12 month C1105 is complete and removes the 6 and 9 month limits for C1105 in accordance with the revised ASTM C1105 specification.

**Publication:** Engineering Policy Guide: 106.3.2.93

## **Issue 9: Design Exception Process Update**

**Approval:** Level 2 – Assistant Chief Engineer

**Sponsor:** Jennifer Becker – DE

**Summary:** Revisions to language for clarity and to reflect current practices in response to 2021 Audits and Investigation internal audit.

**Publication:** Engineering Policy Guide: 109, 131

**Issue 10: Utility Accommodation Policy**

**Approval: Level 2 – Assistant Chief Engineer**

Sponsor: Jennifer Becker – DE

Summary: In 2020, FHWA conducted an audit of MoDOT's utility practices. A full rewrite of the EPG language was determined necessary to adequately address all FHWA comments on 2023 draft and existing language.

Publication: Engineering Policy Guide: 236.5.12, 643

**Issue 11: License Plate Reader (LPR) Installation**

**Approval: Level 2 – Assistant Chief Engineer**

Sponsor: Raymond Shank – TS

Summary: Updating License Plate Reader installation details to incorporate MASH compliant breakaway assemblies and clarifying language for third party responsibilities and district involvement.

Publication: Engineering Policy Guide: 236.5.29, 941.10.2



## SECTION 403

### ASPHALTIC CONCRETE PAVEMENT

**403.1 Description.** This work shall consist of providing a bituminous mixture to be placed in one or more courses on a prepared base or underlying course as shown on the plans or as directed by the engineer. The contractor shall be responsible for QC of the bituminous mixture, including the design, and control of the quality of the material incorporated into the project. The engineer will be responsible for QA, including testing, to assure the quality of the material incorporated into the project.

**403.1.1 Naming Convention.** The nomenclature of Superpave bituminous mixture names, such as SP125CLP, will be as follows. When only the aggregate size is shown, such as SP125, the specifications shall apply to all variations of that size, such as SP125B, SP125C, SP125CLP, etc. When "x" is indicated, such as SP125xLP, specifications shall apply to all variations of mixture designs. Stone Matrix Asphalt will be generally referred to as SMA and designated by SM or SMR. Balanced Mix Design (BMD) is required on all dense graded SP095 and SP125 surface and base course mixtures as specified herein. All other mixtures, SP048, SP190, SP250, and SM/SMR mixtures shall be considered non-BMD mixtures.

Superpave Nomenclature	
SP	Superpave
048	4.75mm (No. 4) nominal aggregate size
095	9.5 mm (3/8 inch) nominal aggregate size
125	12.5 mm (1/2 inch) nominal aggregate size
190	19.0 mm (3/4 inch) nominal aggregate size
250	25.0 mm (1 inch) nominal aggregate size
x	Mixture design: B, C, E or F (as described below)
LP	Limestone porphyry (when designated)
SM	Stone Matrix Asphalt (when designated)
SMR	Stone Matrix Asphalt limestone/non-carbonate (when designated)

**403.1.2 Design Levels.** The following cumulative equivalent single axle loads (ESALs) shall be used for the specified mix design. The same size aggregate mix design at a higher design traffic may be substituted at the contractor's expense for the contract specified mixture design with the approval from the engineer. Substitutions shall be done uniformly and project mixing of various designs for the same work will not be permitted. For example, an SP125B mixture may be substituted for an SP125C mixture, or SP190C for SP190E, etc. Mixture design substitution will be limited to one design level higher than that specified in the contract.

Design Traffic (ESALs)	Design
< 300,000	F
300,000 to < 3,000,000	E
3,000,000 to < 30,000,000	C
≥ 30,000,000	B

**403.2 Material.** All material shall be in accordance with Division 1000, Material Details, and specifically as follow:

Item	Section
Aggregate	1002
Asphalt Binder, Performance Graded (PG) <sup>a</sup>	1015
Fiber Additive	1071
Anti-Strip Additive	1071

<sup>a</sup>The grade of asphalt binder will be specified in the contract.

**403.2.1 Fine Aggregate Angularity.** Fine aggregate angularity (FAA) shall be measured on the fine portion of the blended aggregate. When tested in accordance with AASHTO T 304 Method A, aggregate particles passing the No. 8 sieve shall meet the following criteria for the minimum percent air voids in loosely compacted fine aggregate:

Design <sup>b</sup>	FAA
F	-- <sup>a</sup>
E	40
C	45
B	45

<sup>a</sup> For SP048 Mixtures the FAA shall be a minimum of 40

<sup>b</sup> [FAA requirements will be waived for BMD SP095 and SP125 Mixtures](#)

**403.2.2 Coarse Aggregate Angularity.** Coarse aggregate angularity (CAA) shall be measured on the coarse portion of the blended aggregate. When tested in accordance with ASTM D 5821, the coarse aggregate shall meet the following criteria. Crushed limestone, dolomite, steel slag and porphyry will be considered as having 100 percent two fractured faces unless visual observations indicate an undesirable particle shape is being produced.

Design	CAA <sup>a,b</sup>
F	55/None
E	75/None
C	95/90
B	100/100

<sup>a</sup>The criteria denotes the minimum allowable percentage of the coarse aggregate with "one/two" fractured faces, such as a "95/90" requirement, means that the coarse aggregate shall have a minimum of 95 percent particles by weight with one fractured face and a minimum of 90 percent particles by weight with two fractured faces.

<sup>b</sup> [CAA requirements will be waived for BMD SP095 and SP125 mixtures.](#)

**403.2.3 Clay Content.** When tested in accordance with AASHTO T 176, blended aggregate particles passing the No. 4 sieve shall meet the following minimum sand equivalent criteria:

Design	Sand Equivalent <sup>a</sup>
F	40
E	40
C	45
B	50

<sup>a</sup> Clay content requirements will be waived for BMD SP095 and SP125 mixtures.

**403.2.4 Thin, Elongated Particles.** For all non-BMD mixtures except SMA, the blended aggregate particles retained on the No. 4 sieve shall not exceed 10 percent, based on a ratio of 5:1 when tested for flat and elongated particles in accordance with ASTM D 4791. Thin and elongated particle testing will be waived on BMD SP095 and SP125 mixtures.

**403.2.5 Stone Matrix Asphalt.** In addition to other requirements, material for SMA mixtures shall meet the following. Coarse aggregate shall consist of crushed limestone and either porphyry, ~~or~~ steel slag, or other approved hard durable aggregates in accordance with the quality requirements of [Sec 1002](#), except as follows. The Los Angeles (LA) abrasion, when tested in accordance with AASHTO T 96, shall not exceed 40 percent based on initial ledge approval and source approval. The percent absorption, when tested in accordance with AASHTO T 85, shall not exceed 3.5 percent based on the individual fractions. The amount of flat and elongated particles, measured on material retained on a No. 4 sieve, of the blended aggregate shall not exceed 20 percent based on a 3:1 ratio or 5 percent based on a 5:1 ratio.

**403.2.5.1 Filler Restriction.** Rigid void content determined in accordance with MoDOT Test Method TM-73 shall be no greater than 50 percent.

**403.2.5.2 Fibers.** A fiber additive shall be used as a stabilizer in SMA Mixtures. Fibers shall be uniformly distributed by the end of the plant mixing process. The dosage rate for fibers shall be no less than 0.3 percent by weight of the total mixture for cellulose and no less than 0.4 percent by weight for mineral fibers.

**403.2.6 Reclaimed Asphalt.** A maximum of 30 percent virgin effective binder replacement may be used in mixtures without changing the grade of binder. The asphalt binder content of recycled asphalt materials shall be determined in accordance with AASHTO T 164, ASTM D 2172 or other approved method of solvent extraction. A correction factor for use during production may be determined for binder ignition by burning a sample in accordance with AASHTO T 308 and subtracting from the binder content determined by extraction. The aggregate specific gravity shall be determined by performing AASHTO T 209 in accordance with [Sec 403.19.3.1.2](#) and calculating the  $G_{se}$  to which a 0.98 correction factor will be applied to obtain the  $G_{sb}$  as follows:

$$G_{se} = \frac{100 - P_b}{\frac{G_{mm}}{G_b} - P_b} \quad \text{RAP } G_{sb} = \text{RAP } G_{se} \times 0.98$$

**403.2.6.1 Reclaimed Asphalt Pavement.** Reclaimed Asphalt Pavement (RAP) may be used in any mixture, except SMA mixtures. Mixtures may be used with more than 30 percent virgin effective binder replacement provided testing according to AASHTO M 323 is included with the job mix formula that ensures the combined binder meets the grade specified in the contract. All RAP material, except as noted below, shall be tested in accordance with AASHTO T 327, *Method of Resistance of Coarse Aggregate Degradation by Abrasion in the Micro-Deval Apparatus*. Aggregate shall have the asphalt coating removed either by extraction or binder ignition during production. The material shall be tested in the Micro-Deval apparatus at a frequency of once per 1500 tons. The percent loss shall not exceed the Micro-Deval loss of the combined virgin material by more than five percent. Micro-Deval testing will be waived for RAP material obtained from MoDOT roadways. All RAP material shall be in accordance with [Sec 1002](#) for deleterious and other foreign material.

**403.2.6.2 Reclaimed Asphalt Shingles.** Reclaimed Asphalt Shingles (RAS) may be used in any mixture specified to use PG 64-22 in accordance with AASHTO PP 53 except as follows: When the ratio of virgin effective binder to total binder in the mixture is between 60 and 70 percent, the grade of the virgin binder shall be PG 52-28 or PG 58-28. Shingles shall be ground to 3/8-inch minus. Waste, manufacturer or new, shingles shall be essential free of deleterious materials. Post-consumer RAS shall not contain more than 1.5 percent wood by weight or more than 3.0 percent total deleterious by weight. Post-consumer RAS shall be certified to contain less than the maximum allowable amount of asbestos as defined by national or local standards. The gradation of the aggregate may be determined by solvent extraction of the binder or using the following as a standard gradation:

Shingle Aggregate Gradation	
Sieve Size	Percent Passing by Weight
3/8 in.	100
No. 4	95
No. 8	85
No. 16	70
No. 30	50
No. 50	45
No. 100	35
No. 200	25

### 403.3 Composition of Mixtures.

**403.3.1 Gradation.** Prior to mixing with asphalt binder, the combined aggregate gradation, including filler if needed, shall meet the following gradation for the type of mixture specified in the contract. A job mix formula may be approved which permits the combined aggregate gradation during mixture production to be outside the limits of the master range when the full tolerances specified in [Sec 403.5](#) are applied.

Sieve Size	Percent Passing by Weight						
	SP250	SP190	BMD SP125	BMD SP095	SP048	SP125xSM(R)	SP095xSM(R)
1 1/2 in.	100	---	---	---	---	---	---
1 in.	90 - 100	100	---	---	---	---	---
3/4 in.	90 max.	90 - 100	100	---	---	100	---
1/2 in.	---	90 max.	90 - 100	100	---	90-100	100
3/8 in.	---	---	90 max.	90-100	100	50-80	70-95
No. 4	---	---	---	90 max.	90-100	20 - 35	30-50
No. 8	19 - 45	23 - 49	28 - 58	32-67	---	16 - 24	20-30
No. 16	---	---	---	---	30-60	---	21 max.
No. 30	---	---	---	---	---	---	18 max.
No. 50	---	---	---	---	---	---	15 max.
No. 100	---	---	---	---	---	---	---
No. 200	1 - 7	2 - 8	2 - 10	2-10	7-12	8.0-11.0	8.0-12.0

**403.3.2 Anti-Strip Agent.** An anti-strip will be allowed by the engineer to improve resistance to stripping. Anti-strip agents and application rates shall be from a list approved in accordance with [Sec 1071](#). [Anti-strip agents shall be required in all mixtures containing flint chat, gravels, individual aggregate fractions containing greater than 5 % by weight of chert, and asphalt](#)

mixtures that have shown poor field performance due to stripping. The liquid anti-strip dosage shall be in the range recommended by the manufacturer and provided in the JMF.

**403.3.3 Porphyry Mixtures.** For LP and SMA mixtures, at least 50 percent by volume of the aggregate shall be crushed porphyry retained on the following sieves: No. 30 for SP048, No. 16 for SP095 and No. 8 for SP125. Depending on the actual gradation of porphyry aggregate furnished, the amount of crushed porphyry required may vary, however at least 40 percent by weight of crushed porphyry will be required. Steel slag may be substituted for porphyry in LP and SM mixtures, except at least 45 percent by weight of crushed porphyry and/or slag will be required. ~~The engineer may approve the use of other~~ Other hard, durable, non-carbonate aggregate such as hard chert, crushed gravel, or flint chat may be used in lieu of ~~addition to~~ porphyry and steel slag provided that an approved anti-strip additive is incorporated into the mix and the mixture passes the Hamburg Wheel Track (HWT) test for the total average rut depth and moisture susceptibility in accordance with Sec 403.4.11.3 and Sec 403.4.11.4, respectively. When an SMR mixture is designated, the mixture shall contain aggregate blends with at least 30 percent non-carbonate material in accordance with [Sec 403.3.5](#).

**403.3.4 Minimum Stone Matrix Asphalt Binder.** The percent asphalt binder for SMA mixtures shall not be less than 6.0 percent unless otherwise allowed and approved by the engineer.

**403.3.5 Surface Mixtures.** Design level B surface mixtures and SP048NC, except as described in [Sec 403.15.3](#), containing limestone coarse aggregate shall contain a minimum amount of non-carbonate aggregate. The LA abrasion values, AASHTO T 96, of the limestone will determine the type and amount of non-carbonate aggregate required as shown in the table below. The LA abrasion value will be determined from the most recent source approval sample. In lieu of the above requirements, the aggregate blend shall have an acid insoluble residue (AIR), MoDOT Test Method TM 76, meeting the plus No. 4 criteria of crushed non-carbonate material. Non-carbonate aggregate shall have an AIR of at least 85 percent insoluble residue.

Coarse Aggregate (+ No. 4)	Minimum Non-Carbonate by Volume
Limestone, LA ≤ 30	30% Plus No. 4
Limestone, LA > 30	20% Minus No. 4 <sup>a</sup>
Dolomite	No Requirement

<sup>a</sup> Use for all SP095 and SP048NC containing limestone.

**403.4 Job Mix Formula.** At least 30 days prior to placing any mixture on the project, the contractor shall submit a mix design for approval to Construction and Materials. The mixture shall be designed in accordance with AASHTO R 35 or R 46 and shall be tested in accordance with AASHTO T 312 except as noted herein. A detailed description of the mix design process shall be included with the job mix formula (JMF). Representative samples of each ingredient for the mixture shall be submitted with the mix design. Aggregate fractions shall be provided in the same proportions as the proposed job mix formula. A minimum of 150 pounds will be required for any individual fraction. The amount of each ingredient submitted shall be as follows for each mix design to be verified:

Ingredient	Minimum Amount
Aggregate	750 Pounds
Hydrated Lime, Mineral Filler and/or Baghouse Fines	20 Pounds)
Asphalt Binder	10 Gallons

**403.4.1 Proficiency Sample Program.** Laboratories that participate in and achieve a score of three or greater in the AASHTO proficiency sample program for T 11, T 27, T 84, T 85, T 166, T 176, T 209, T 304 (ASTM C 1252), T 308 and T 312 will have the mixture verification process

waived. The mix design shall be submitted to Construction and Materials for approval at least seven days prior to mixture production.

**403.4.2 Required Information.** The mix design shall include raw data from the design process and contain the following information:

- (a) All possible sources intended for use, and grade and specific gravity of asphalt binder.
- (b) Source, type (formation, etc.), ledge number if applicable, gradation, and deleterious content of each aggregate fraction.
- (c) Bulk and apparent specific gravities and absorption of each aggregate fraction in accordance with AASHTO T 85 for coarse aggregate and AASHTO T 84 for fine aggregate including all raw data.
- (d) Specific gravity of hydrated lime, mineral filler or baghouse fines, if used, in accordance with AASHTO T 100.
- (e) Percentage of each aggregate component.
- (f) Combined gradation of the job mix.
- (g) Percent asphalt binder, by weight, based on the total mixture and percent asphalt binder contributed by reclaimed asphalt materials.
- (h) Bulk specific gravity ( $G_{mb}$ ) by AASHTO T 166 Method A of a laboratory compacted mixture compacted at  $N_{design}$  gyrations.
- (i) Percent air voids ( $V_a$ ) of the laboratory compacted specimen compacted to  $N_{design}$  gyrations.
- (j) Voids in the mineral aggregate (VMA) and voids in the mineral aggregate filled with asphalt binder (VFA) at  $N_{design}$  gyrations.
- (k) Theoretical maximum specific gravity ( $G_{mm}$ ) as determined by AASHTO T 209, in accordance with [Sec 403.19.3](#), after the sample has been short term aged in accordance with AASHTO R 30.
- (l) The tensile strength ratio as determined by AASHTO T 283 including all raw data.
- (m) The gyratory sample weight to produce a 115 mm minimum height specimen.
- (n) Mixing temperature and gyratory molding temperature.
- (o) Number of gyrations at  ~~$N_{initial}$ ,  $N_{design}$ , and  $N_{maximum}$~~ .
- (p) Dust proportion ratio ( $-200/P_{be}$ ).
- (q) Bulk specific gravity ( $G_{sb}$ ) of the combined aggregate.
- (r) Percent chert contained in each aggregate fraction.
- (s) ~~Percent of  $G_{mm}$  at  $N_{initial}$  and  $N_{maximum}$~~ .

- (~~ts~~) Blended aggregate properties for clay content, angularity, and thin and elongated particles.
- (~~tt~~) Voids in coarse aggregate (VCA) for both the mixture and dry-rodded condition for SMA mixtures.
- (~~tu~~) Draindown for SMA mixtures.
- (~~tv~~) Baghouse fines added for design.

(i) Batch and continuous mix plants – Indicate which aggregate fraction to add baghouse percentage during production.

(ii) Drum mix plants – Provide cold feed settings with and without baghouse percentage.

(w) For BMD SP095 and SP125 mixtures all test results shall be submitted along with the raw data. BMD testing shall include Cracking Tolerance Index (CT<sub>Index</sub>), Long-Term aged Cracking Tolerance Index (CT<sub>Index, Long-Term Aged</sub>), Hamburg Wheel Tracking (HWT) Testing, Rutting Tolerance Index (RTI<sub>Index</sub>), and Moisture Susceptibility results from the HWT test or Tensile Strength Ratio (TSR).

**403.4.3 Approval.** No mixture will be accepted for use until the JMF for the project is approved by Construction and Materials.

**403.4.4 Job Mix Formula Modification.** The JMF approved for each mixture shall be in effect until modified in writing by the engineer. When unsatisfactory results occur or should a source of material be changed, a new JMF may be required.

**403.4.5 Design Gyration.** The number (N) of gyrations required for gyratory compaction shall be as follows:

Design	<del><sup>b</sup>N<sub>initial</sub></del>	<del><sup>#</sup>N<sub>design</sub></del>	<del><sup>a,b</sup>N<sub>maximum</sub></del>
F	<del>—</del>	50	<del>—</del>
E	<del>7</del>	75	<del>115</del>
C	<del>8</del>	80 or 100	<del>160</del>
<u>BSM/BSMR<del>B</del></u>	<del>9</del>	<u>100</u> <del>125</del>	<del>205</del>
<u>BMD SP095B/C and SP125B/C</u>		<u>60 Min<sup>a</sup></u>	

~~<sup>a</sup>SMA mixtures shall have N<sub>design</sub> equal to 100 and no N<sub>maximum</sub> requirement.~~

~~<sup>b</sup>Design Level C mixtures designed at 80 gyrations shall have no N<sub>initial</sub> or N<sub>maximum</sub> requirements.~~

<sup>a</sup> N<sub>Design</sub> for BMD SP095 and SP125 may exceed 60 gyrations.

~~In addition, the compaction level, as a percent of theoretical maximum specific gravity, shall be less than or equal to 91.5 percent for Design F, 90.5 percent for Design E and 89.0 percent for Designs C and B at N<sub>initial</sub>, equal to 96.0 percent at N<sub>design</sub> and less than or equal to 98.0 percent at N<sub>maximum</sub>.~~

**403.4.6 Mixture Characteristics.** When compacted in accordance with AASHTO T 312, the mixture shall meet the following criteria.

**403.4.6.1 Air Voids ( $V_a$ ).** ~~Design air voids for all mixtures at all traffic levels shall be 4.0.~~ Design air voids for BMD SP095 and SP125 mixtures shall be between 3.0 and 5.0 percent. For SM/SMR and SP048 mixtures, the design air voids shall be 4.0 percent. Design air voids for SP190 and SP250 mixtures shall be 3.0 percent.

**403.4.6.2 Voids in the Mineral Aggregate (VMA).** BMD SP095 mixtures shall have minimum volume of effective asphalt of 12.0 percent and BMD SP125 mixtures shall have a minimum volume of effective asphalt of 11.0 percent. The minimum VMA for BMD SP095 and SP125 mixtures shall be equal to the minimum volume of effective binder ( $V_{be}$ ) plus the design air voids.

Mixture	VMA Minimum (percent)
SP250	12.0
SP190	13.0
<del>BMD SP125</del> (except for SMA)	<del>14.0</del> $V_{be} \text{ Minimum} + V_{a\text{Design}}$
<del>BMD SP095</del> (except for SMA)	<del>15.0</del> $V_{be} \text{ Minimum} + V_{a\text{Design}}$
SP048	16.0
SMA	17.0

**403.4.6.3 Voids Filled With Asphalt (VFA).** The minimum VFA for BMD SP095 and SP125, SP190, and SP250 mixtures shall be 72 percent. SMA and SP048 mixtures shall have a minimum VFA of 75 percent.

Design	VFA (percent) <sup>a</sup>
<del>F</del>	<del>70—80</del>
<del>E</del>	<del>65—78</del>
<del>C</del>	<del>65—75<sup>b</sup></del>
<del>B</del>	<del>65—75<sup>b</sup></del>

<sup>a</sup>~~SMA and SP048 mixtures shall have a minimum VFA of 75 percent.~~

<sup>b</sup>~~Maximum 76 percent for SP095 and 78 percent for SP048.~~

**403.4.7 Dust to Binder Ratio.** For all mixtures except SMA and SP048, the ratio of minus No. 200 material to effective asphalt binder ( $P_{be}$ ) shall be between 0.8 and 1.6. For SP048, the ratio of minus No. 200 material to effective asphalt binder ( $P_{be}$ ) shall be between 0.9 and 2.0.

**403.4.8 Moisture Susceptibility.** ~~For all mixtures except SMA, the mixture shall have a tensile strength ratio (TSR) greater than 80 percent when compacted to 3.7 inches with  $7 \pm 0.5$  percent air voids and tested in accordance with AASHTO T 283. SMA mixtures shall have a TSR greater than 80 percent when compacted to 3.7 inches with  $6 \pm 0.5$  percent air voids and tested in accordance with AASHTO T 283.~~

For all asphalt mixtures, the mix design shall demonstrate a tensile strength ratio (TSR) greater than 85 percent, or greater than 80 percent when an approved anti-strip agent is used, when the mixture is compacted to 3.7 inches with  $7.0 \pm 0.5$  percent air voids for non-SMA mixtures and  $6.0 \pm 0.5$  percent air voids for SMA mixtures, and tested in accordance with AASHTO T 283.

For BMD SP095 and SP125 mixtures, the HWT moisture susceptibility tests may be used in lieu of TSR and tested in accordance with MoDOT TM-100. The HWT moisture susceptibility criteria shall be in accordance with Sec 403.4.11.4.

**403.4.9 Draindown.** AASHTO T 305, Draindown Test, shall be performed on all SMA mixtures prior to job mix approval. The mixture shall be stabilized in such a way that the draindown of the asphalt binder shall not exceed 0.3 percent by weight of mixture.

**403.4.10 Voids in Coarse Aggregate.** The percent  $VCA_{MIX}$  of SMA mixtures shall be less than or equal to the  $VCA_{DRC}$  as determined using AASHTO T 19. This may be calculated using the following equations:

$$VCA_{DRC} = 100 \times (G_{CA}\gamma_w - \gamma_s) / G_{CA}\gamma_w$$

$$VCA_{MIX} = 100 - (P_{bp} \times G_{mb} / G_{CA})$$

$$P_{bp} = P_s \times PA_{bp}$$

Where:

$G_{CA}$	=	bulk specific gravity of the combined coarse aggregate (AASHTO T 85),
$\gamma_s$	=	unit weight of coarse aggregate in the dry-rodded condition (DRC) (lb/ft <sup>3</sup> ) (AASHTO T 19),
$\gamma_w$	=	unit weight of water (62.34 lb/ft <sup>3</sup> ),
$P_{bp}$	=	percent aggregate by total mixture weight retained on No. 4 sieve and
$PA_{bp}$	=	percent aggregate by total aggregate weight retained on No. 4 sieve*.

\*Use No. 8 sieve for SP095xSM

**403.4.11 Performance Testing Requirements for BMD SP095 and SP125 Mixtures.** Acceptable test results meeting the criteria of the following performance tests shall be submitted with the mix design for approval. Test specimens shall be compacted to an air void content of  $7.0 \pm 0.5$  percent.

**403.4.11.1 Cracking Tolerance Index ( $CT_{Index}$ ) Testing.** The  $CT_{Index}$  testing shall be completed in accordance with ASTM D8225 and at a test temperature of  $25 \pm 0.5$  C. BMD SP095 and SP125 mixtures shall meet the following criteria.

<u>Mix Type</u>	<u>Minimum <math>CT_{Index}</math></u>	<u>Minimum <math>CT_{Index, (Long-Term Aged)}^a</math></u>
<u>BMD SP095 and SP125 Mixtures</u>	<u>50</u>	<u>15</u>

<sup>a</sup> Long-Term Aged defined as loose mix aging for 20 hours at 115 C.

**403.4.11.2 Rutting Tolerance Index ( $RT_{Index}$ ) Testing.** The  $RT_{Index}$  testing shall be completed in accordance with ASTM D8360 and at a test temperature of  $50 \pm 1$  C and should meet the following criteria for the contract binder grade of the mixture.

<u>Binder Contract Grade<sup>(a)</sup></u>	<u>Minimum RT<sub>Index</sub><sup>(b)</sup></u>
<u>58-28H / 64-22</u>	<u>50</u>
<u>64-22H / 70-22</u>	<u>65</u>
<u>64-22V / 76-22</u>	<u>80</u>

<sup>(a)</sup> Determined by the binder grade specified in the contract.

<sup>(b)</sup> The RT<sub>Index</sub> test value shall be reported, but the Hamburg wheel track test (HWT) rutting requirement shall govern mixture acceptance.

**403.4.11.3 Hamburg Wheel Track (HWT).** HWT testing will be completed in accordance with AASHTO T 324 at test temperature of  $50 \pm 1$  C and 2.44 inch specimen height. All HWT testing shall be conducted with 20,000 passes along with the raw data.

<u>Binder Contract Grade<sup>(a)</sup></u>	<u>Minimum Wheel Passes</u>	<u>Maximum Rut Depth (mm)</u>
<u>58-28H / 64-22</u>	<u>7,500</u>	<u>10</u>
<u>64-22H / 70-22</u>	<u>15,000</u>	<u>10</u>
<u>64-22V / 76-22</u>	<u>20,000</u>	<u>10</u>

<sup>(a)</sup> Determined by the binder grade specified in the contract.

**403.4.11.4 Hamburg Wheel Track (HWT) Moisture Susceptibility Requirements.** If elected by the contractor for BMD SP095 and SP125 mixtures or when required by the mix design, one of the following moisture susceptibility criteria may be used in lieu of TSR using total rut depth, slope ratio (SR), and stripping inflection point (SIP) to determine passing moisture resistance using the HWT. The HWT test shall be completed to 20,000 passes regardless of the contract grade for calculating the SR and the SIP in accordance with MoDOT TM-100.

<u>Parameter</u>	<u>Stripping Criteria</u>	<u>Outcome</u>
<u>Total Rut Depth</u>	<u>Less Than or Equal to 4 mm</u>	<u>Passes Stripping Test</u>
<u>Slope Ratio (SR)</u>	<u>Less Than 2.0</u>	<u>Passes Stripping Test</u>
<u>Stripping Inflection Point (SIP)</u>	<u>Greater Than 15,000 passes</u>	<u>Passes Stripping Test</u>

#### 403.5 Mixture Production Specification Limits.

**403.5.1 Gradation and Deleterious Content Control.** The gradation of the aggregate shall be determined from samples taken from the hot bins on batch-type or continuous mixing plants or from the composite cold feed belt on drum mix plants. The gradation may also be obtained by sampling the mixture and testing the residual aggregate. The deleterious content of the aggregate shall be determined from samples taken from the composite cold feed belt. Aggregate samples shall be taken in accordance with AASHTO R 90. The RAP shall be sampled from the RAP feeding system on the asphalt plant. The contractor shall determine ~~on a daily basis at minimum,~~ the gradation on the aggregate reclaimed from the RAP by either extraction or binder ignition. The results shall be used to determine ~~the daily~~ specification compliance for the combined gradation.

**403.5.1.1 Stone Matrix Asphalt Tolerances.** In producing mixtures for the project, the plant shall be operated such that no intentional deviations from the job mix formula are made. The maximum deviation from the approved job mix formula shall be as follows for SMA mixtures:

<u>Sieve</u>	<u>Max. Tolerance</u>	
	<u>SP095</u>	<u>SP125</u>
<u>3/4 in.</u>	<u>---</u>	<u>---</u>

1/2 in.	---	±4
3/8 in.	±4	±4
No. 4	±3	±3
No. 8	±3	±3
No. 200	±2	±2

**403.5.1.2 Mixture Tolerance.** For all other SP mixtures, the percent passing the first sieve size smaller than the nominal maximum size shall not exceed 92.0 percent, a tolerance not to exceed 2.0 percent on the No. 8 sieve from the table in [Sec 403.3.1](#), and within the range listed in [Sec 403.3.1](#) for the No. 200 sieve. The deleterious content of the material retained on the No. 4 sieve shall not exceed the limits specified in [Sec 1002.2](#).

**403.5.2 Density.** The final, in-place density of the mixture shall be ~~94.5 ± 2.5~~ 92.5 to 98.5 percent of the theoretical maximum specific gravity for all mixtures except SMA. SMA mixtures shall have a minimum density of 94.0 percent of the theoretical maximum specific gravity. The theoretical maximum specific gravity shall be determined from a sample representing the material being tested. Tests shall be taken not later than the day following placement of the mixture. The engineer will randomly determine test locations.

**403.5.2.1 Non-Integral Shoulder Density.** ~~Density on non-integral shoulders shall be in accordance with Sec 403.15.3. Non-integral shoulders with subgrade or base density controls per Sec 209 shall meet the specified density requirements for the mixture. For non-integral shoulders constructed on an existing older paved shoulder, or on a subgrade or base that does not require Sec 209 subgrade preparation, density requirements shall be in accordance with Sec 401.7.8. All compaction shall be completed within the compaction temperature range of the asphalt mixture in accordance with Sec 403.15.~~

**403.5.2.2 Integral Shoulder Density.** ~~When shoulders are placed integrally with the traveled way, density tests shall be taken on the traveled way for density pay factors. The rolling pattern for an integral shoulder shall be the same as that used for the mainline traveled way unless compaction causes pavement distress. If distress occurs, the contractor shall immediately notify the engineer and develop a rolling pattern that provides optimum density and performance. After a rolling pattern has been shown to achieve optimum density, it shall be used in place of density testing unless material, location, subgrade condition, or temperature changes. The engineer may require additional density tests to confirm that optimum density is obtained. All compaction shall be completed within the compaction temperature range of the asphalt mixture in accordance with Sec 403.15.~~ ~~When shoulders are placed integrally with the traveled way, tests shall be taken on the traveled way.~~

**403.5.2.3 Unconfined Longitudinal Joint Density.** Density along unconfined longitudinal joints shall be in accordance with [Sec 403.16.1](#) and [Sec 403.23.6](#).

**403.5.3 Asphalt Content.** The asphalt content (AC) shall be within ± 0.3 percent of the approved mix design.

**403.5.4 Voids in the Mineral Aggregate.** The VMA shall be within – 0.5 and + 2.0 percent of the minimum required for each type of mixture at  $N_{des}$  gyrations.

**403.5.5 Air Voids.** Air voids shall be within ± 1.0 percent of the approved mix design at  $N_{des}$  gyrations.

**403.5.6 Tensile Strength Ratio.** The TSR shall be greater than or equal to ~~80~~<sup>75</sup> percent as determined from loose mixture taken from the asphalt plant roadway and tested in accordance with AASHTO T 283.

**403.5.7 Aggregate Properties.** Aggregate properties from Sec 403.2 on the combined aggregate during production shall be no less than 2 percent below the minimum for FAA, no less than 5 percent below the minimum for CAA, no less than 5 percent below the minimum for clay content and no more than 2 percent above the maximum for thin, elongated particles. Samples are to be taken from the combined cold feed whether from a drum-mix plant or a batch plant. Samples are to be taken in accordance with AASHTO R 90. Testing of aggregate consensus properties for BMD SP095 and SP125 mixtures are waived.

**403.5.8 Fibers.** The fiber proportioning and delivery system for SMA mixtures shall have an accuracy of 10 percent by weight of the material actually being measured in any given period of time.

**403.5.9 Moisture Content.** The asphaltic concrete mixture, when sampled and tested in accordance with AASHTO T 329, shall not contain more than 0.5 percent moisture by weight of the mixture.

**403.5.10 Contamination.** The asphaltic concrete mixture shall not be contaminated with deleterious agents such as unburned fuel, objectionable fuel residue or any other material not inherent to the job mix formula.

403.5.11 BMD SP095 and SP125 Mixture Testing. BMD SP095 and SP125 mixtures performance testing shall have favorable QC/QA comparisons and meet the minimum criteria described herein.

403.5.11.1 Cracking Tolerance Index (CT<sub>Index</sub>). Minimum CT<sub>Index</sub> shall be 50 for BMD SP095 and SP125 mixtures.

403.5.11.2 Mixture Stability. Minimum Rutting Tolerance Index (RT<sub>Index</sub>) or maximum rutting measured by the Hamburg Wheel Track (HWT) test shall be in accordance with the following:

<u>Contract Binder Grade<sup>(a)</sup></u>	<u>Minimum RT<sub>Index</sub><sup>(b)</sup></u>	<u>Maximum Average Rut Depth by HWT (mm)<sup>(c)</sup></u>
<u>58-28H / 64-22</u>	<u>50</u>	<u>12.5 mm @ 7,500 Passes</u>
<u>64-22H / 70-22</u>	<u>65</u>	<u>12.5 mm @ 15,000 Passes</u>
<u>64-22V / 76-22</u>	<u>80</u>	<u>12.5 mm @ 20,000 Passes</u>

<sup>(a)</sup> Determined by the contract binder grade specified in the contract.

<sup>(b)</sup> HWT testing may replace RT<sub>Index</sub> testing for contract compliance. A minimum RT<sub>Index</sub> may be established during production for correlation with HWT results; however, this is permitted only when the measured HWT rut depth during production is 10 mm or less. If the HWT rut depth is 10 mm or less, the lower RT<sub>Index</sub> value shall govern. Mixtures failing to meet the minimum RT<sub>Index</sub> or the correlated minimum RT<sub>Index</sub> shall be tested using the HWT.

<sup>(c)</sup> Raw data for the HWT shall be provided for 20,000 passes for all mixtures regardless of binder contract grade. Maximum HWT rut depth of 12.5 mm of rutting shall be determined at the required number of passes for the contract asphalt binder grade.

403.5.11.3 Moisture Susceptibility of BMD SP095 and SP125 Mixtures. Moisture susceptibility shall be measured by TSR or by HWT tests. The TSR shall be greater than or

equal to 80 percent as determined from loose mixture taken from the plant and tested in accordance with AASHTO T 283. Alternatively, the moisture susceptibility shall pass one of the following criteria in the following table from the HWT test for maximum average rutting, slope ratio (SR), or stripping inflection point (SIP) in accordance with MoDOT TM-100.

<b>Hamburg Wheel Track (HWT) Moisture Susceptibility (Stripping) Criteria</b>		
<b>Parameter</b>	<b>Stripping Criteria</b>	<b>Outcome</b>
Total Rut Depth	Less Than or Equal to 4 mm	Passes Stripping Test
Slope Ratio (SR)	Less Than 2.0	Passes Stripping Test
Stripping Inflection Point (SIP)	Greater Than 15,000 passes	Passes Stripping Test

**403.5.11.3.1 Moisture Susceptibility for the Acceptance of other Hard Durable Aggregates in Porphyry Mixtures.** HWT shall be used during production to evaluate moisture susceptibility for acceptance when other hard durable aggregates are used in lieu of either crushed porphyry or steel slag.

**403.6 Field Laboratory.** The contractor shall provide a Type 3 field laboratory in accordance with Sec 601. The contractor shall furnish the bituminous mixture equipment to perform all required test methods for QC and QA work. The gyratory compactor shall be evaluated in accordance with AASHTO PP 35. An approved list will be maintained by Construction and Materials. All other equipment shall be capable of performing tests in accordance with the approved test methods.

**403.7 Bituminous Mixing Plants.** Bituminous mixing plants and preparation of material and mixtures shall be in accordance with Sec 404.

**403.8 Hauling Equipment.** Trucks used for hauling bituminous mixtures shall be in accordance with Sec 404.

**403.9 Pavers.** Bituminous pavers shall be self-contained units, provided with an activated screed or strike-off assembly, heated if necessary, and capable of spreading and finishing asphaltic concrete in lane widths applicable to the specified typical sections and thicknesses shown on the plans.

**403.10 Construction Requirements.**

**403.10.1 Weather Limitations.** No mixture shall be placed on any wet or frozen surface. No mixture shall be placed when either the air temperature or the temperature of the surface on which the mixture is to be placed is below 40 F. Temperatures shall be obtained in accordance with MoDOT Test Method TM 20.

**403.10.2 Substitutions.** With approval from the engineer, the contractor may substitute a smaller nominal maximum size mixture for a larger sized mixture. Specifications governing the substitute mixture shall apply. Except for a single surface layer, the total pavement thickness shall be maintained when the substitute mixture layer is reduced as allowed in Sec 403.13 by increasing the thickness of other layers or courses. The contract unit price for the original mixture shall be used.

**403.11 Field Adjustments of Job Mix Formulas.** When test results indicate the mixture produced does not meet the specification requirements, the contractor may field adjust the job mix formula as noted herein. Field adjustments may consist of changing the percent binder as listed on the original approved job mix by no more than 0.3 percent. Additional fractions of material or new material will not be permitted as field adjustments. The engineer shall be

notified immediately when any change is made in the cold feed settings, the hot bin settings or the binder content. A new  $G_{sb}$  shall be calculated using the new aggregate percentages. The gradation of the adjusted mixture shall meet the requirements of the mixture type specified in the contract. When the binder content is adjusted more than 0.3 percent, the mixture will be considered out of specification, and a new mix design shall be established.

**403.11.1 Field Mix Redesign.** When a new mix design will be required, the contractor will be permitted to establish the new mix design in the field. The mixture shall be designed in accordance with AASHTO R 35 or AASHTO R 46 and shall meet the mix design requirements, [balanced mix design requirements \(if required\)](#), including [TSR or HWT moisture susceptibility requirements](#). A representative sample of the mixture shall be submitted with the new mix design to the Central Laboratory for mixture verification. The amount of mixture submitted for verification shall weigh at least 50 pounds.

**403.11.1.1 Approval.** New mix designs established in the field shall be submitted for approval to Construction and Materials. Upon approval, Construction and Materials will assign a new mix number to the mixture.

**403.11.1.2 Resume Production.** No mixture shall be placed on the project until the new field mix design is approved.

**403.12 Application of Prime or Tack.** The prime coat, if specified, shall be applied in accordance with [Sec 408](#). A tack coat is required on all existing pavement and shoulder surfaces that will be overlaid with a bituminous mixture. A tack coat is also required between all lifts of bituminous pavements placed within the driving and turn lanes, unless otherwise specified in the contract. All construction requirements of a tacked surface shall be in accordance with [Sec 407](#), and specified herein. The tack coat shall be applied uniformly and shall completely cover the surface upon which the bituminous mixture is to be placed. Placement of a bituminous mixture shall not be placed upon a tacked surface that is not uniformly covered or surfaces that have experienced excessive loss of tack due to tracking. Re-application of tack due to excess tracking or non-uniform coverage shall be at the contractor's expense.

**403.13 Spreading and Finishing.** The base course, primed or tacked surface, or preceding course or layer shall be cleaned of all dirt, packed soil or any other foreign material prior to spreading the asphaltic mixture. If lumps are present or a crust of mixture has formed, the entire load will be rejected. The thickness and width of each course shall conform to the typical section in the contract. The contractor may elect to construct each course in multiple layers. The minimum compacted thickness [as a wearing surface](#) shall be [0.751 inches](#) for SP048, [1.251.5 inches](#) for SP095, [1.752](#) inches for SP125, [23](#) inches for SP190, and [34](#) inches for SP250. [For leveling courses, the minimum compacted thickness can be reduced by 0.25-inches.](#)

**403.13.1 Uneven Lanes.** For roadways constructed under traffic, uneven pavement lanes shall not be left in place for more than seven days, unless approved by the engineer.

**403.13.2 Segregation.** No segregation will be permitted in handling the mixture at the plant, from the truck or during spreading operations on the roadbed. All layers shall be feathered out, by hand raking if necessary, in transitioning the depth of the surface to meet present grades at bridges or ends of projects, to provide a uniform, smooth riding surface free of irregularities. Where only the top layer of the surfacing continues across a bridge, the bottom layers shall be feathered out. In situations where there is a dispute in the existence of segregation, the area in question will be tested in accordance with MoDOT Test Method TM 75. Mixture production shall immediately cease if either criteria of MoDOT Test Method TM 75 fail. Segregated mixture shall be removed and replaced to the limits determined by the engineer.

**403.13.2.1 Paver Mounted Thermal Profiling (PMTTP).** PMTTP data shall be required behind the asphalt paver on the roadway for BMD SP095 and SP125 mixtures. For all other asphalt mixtures, a material transfer vehicle (MTV) shall be required.

**403.13.3 Release to Traffic.** If the asphaltic concrete construction consists of more than a single layer, each layer shall be compacted as specified and allowed to cool to the ambient temperature before the next layer is placed. The contractor shall keep traffic off the asphaltic concrete until the surface of the asphaltic concrete is 140 F or below and the asphaltic concrete has cooled sufficiently to prevent flushing of the asphalt binder to the surface, marking or distorting the surface or breaking down the edges.

**403.13.4 Draindown.** Evidence of asphalt binder separation or draindown at delivery will be cause for rejection.

**403.13.5 Shoulder Substitution.** When a [Sec 403](#) mixture is specified for traffic lanes, the same mixture may be used for the adjacent shoulder, subject to the density requirements in [Sec 403.5.2](#).

**403.14 Spot Wedging and Leveling Course.** The engineer will specify the locations and thickness of spot wedging and the thickness of leveling course to obtain the smoothest possible riding surface. This procedure may result in spot wedging operations over small areas with feather-edging at high points and ends of wedge areas. Rigid control of the placement thickness of the leveling course shall be required. Leveling course, consisting of a layer of asphaltic concrete of variable thickness used to superelevate curves and eliminate irregularities in the existing base, shall be spread uniformly to the specified profile grade and cross section. The mixture shall be uniformly spread and compacted, with only minor segregation as accepted by the engineer. Type SP125 or finer mixtures, as applicable, shall be used for the spot wedging and for the leveling course.

**403.15 Compaction.** After the asphaltic mixture has been spread, struck off and surface irregularities adjusted, the asphaltic mixture shall be compacted thoroughly and uniformly by rolling to obtain the required compaction while the mixture is in a workable condition. Excessive rolling, to the extent of aggregate degradation, will not be permitted. Rollers shall not be used in the vibratory mode when the mixture temperature is below 225 F. When warm mix technology is used, as approved by the engineer, rollers shall not be used in the vibratory mode when the mixture temperature is below 200 F.

**403.15.1 Rolling.** Any displacement occurring as a result of starting, stopping or changing direction of a roller, or from other causes, shall be avoided. Excess liquid, to prevent adhesion of the mixture to the rollers, will not be permitted. Diesel fuel, fuel oil or other detrimental products shall not be used as wetting agents. Along forms, curbs, headers, walls and other places not accessible to the roller, the mixture shall be thoroughly compacted with hot hand tampers, smoothing irons or with mechanical tampers.

**403.15.2 Defective Mixture.** Any mixture that becomes loose and broken, mixed with dirt or is in any way defective shall be removed and replaced with fresh, hot mixture, which shall be compacted to conform with the surrounding area. Any area showing an excess or deficiency of asphalt binder shall be removed and replaced.

**403.15.3 [Other Non-Traffic Areas.](#)** ~~See 403 mixtures used for surfacing medians and similar areas, shoulders adjacent to rigid or flexible pavement and shoulders adjacent to resurfaced pavement shall be compacted to the specified densities for the mixture. Once an established rolling pattern has been demonstrated to provide the required density for shoulders, at the~~

~~engineer's discretion, the pattern may be used in lieu of density tests provided no changes in the material, typical location or temperatures are made. Regardless of the method, density will still be required and subject to testing as deemed necessary by the engineer. In lieu of roller and density requirements, temporary bypasses to be maintained at the expense of the contractor shall be thoroughly compacted. The rolling shall be performed at proper time intervals and shall be continued until there is no visible evidence of further consolidation. All mixtures used for other non-traffic areas such as surfacing medians and similar areas with subgrade or base density controls per Sec 209 shall meet the specified density requirements for the mixture. For non-traffic areas constructed on an older existing pavement or on a subgrade or base that does not require Sec 209 subgrade preparation, density requirements shall be in accordance with Sec 401.7.8. Temporary bypasses to be maintained at the expense of the contractor shall be thoroughly compacted in accordance with Sec 401.7.8. All compaction shall be completed within the compaction temperature range of the asphalt mixture in accordance with Sec 403.15.~~

**403.15.4 Density Measurement.** Measurements for determining the in-place density of the mixture shall be taken no later than the day following placement. Measurements not obtained within the prescribed time limits shall be subject to the requirements of [Sec 403.22](#). If a core is taken, material from underlying layers that remain adhered to the core shall be removed in a manner that does not harm the integrity of the specimen. If the contractor elects to place a lift of mixture greater than six times the nominal maximum aggregate size, cores shall be cut in half and the density of each half determined separately.

**403.16 Joints.** Transverse joints shall be formed by any method that will produce a dense, vertical section for use when laying is resumed. When a transverse vertical edge is to be left and opened to traffic, a temporary depth transition shall be built as approved by the engineer. The joint formed when the fresh mixture is placed shall be dense, well sealed, and the grade, line and surface texture of the succeeding surface shall conform to that of the joined surface. If directed by the engineer, the transverse joint shall be painted with a light coating of liquid asphalt. Hand manipulation of the mixture shall be minimized to avoid unsightly surface texture.

**403.16.1 Joint Composition.** Longitudinal joints shall be formed by the use of an edging plate fixed on both sides of the finishing machine. Care shall be taken to obtain a well bonded and sealed longitudinal joint by placing the hot mixture in a manner ensuring maximum compaction at this point. If directed by the engineer for properly sealing the longitudinal joint, a light coating of bituminous material shall be applied to the exposed edge before the joint is made. The minimum density of all traveled way pavement within 6 inches of a longitudinal joint, including the pavement on the traveled way side of the shoulder joint, shall not be less than 2.0 percent below the specified [mat](#) density when unconfined. The density of the longitudinal joint when confined will be included in the evaluation of the remainder of the mat. Each side of the joint shall be flush and along true lines.

**403.16.2 Joint Offset.** The longitudinal joint in any layer shall offset that in the layer immediately below by a minimum of 6 inches; except, the joints in the completed surfacing shall be at the lane lines of the traveled way or other required placement width outside the travel lane. The placement width shall be adjusted such that pavement marking shall not fall on a longitudinal joint.

#### **403.17 Quality Control.**

**403.17.1 Quality Control Operations.** The contractor shall maintain equipment and qualified personnel to perform all QC field inspection, sampling and testing as required by this specification. All contractor personnel included in the QC operation shall be qualified by the MoDOT Technician Certification Program. Under no circumstances will unqualified personnel

be allowed to perform QC sampling or testing. Personnel will be disqualified if acceptable methods and procedures are not followed.

**403.17.1.1 Asphalt Test Results.** The contractor shall record all test results and furnish a copy, including all raw data, to the engineer no later than the beginning of the day following the test. The contractor shall maintain all test results in an organized format and shall be available to the QA inspector at all times. Scale readings and other measurements not directly recorded by electronic media shall be recorded in an organized format. Printouts from gyratory compactors and asphalt content devices shall be retained as part of the testing records.

**403.17.2 Bituminous Quality Control Plan.** Prior to approval of the trial mix design by the engineer, the contractor shall submit a QC Plan to Construction and Materials for approval. The QC Plan shall include:

(a) The contractor representative in charge of QC and the project level representative if different from the contractor representative. Contact information should be recorded for these individuals.

(b) Lot and subplot sizes and how they will be designated.

(c) [Where samples will be taken - Plant or roadway sampling.](#)

(d) The test method for determining asphalt content, [BMD tests \(if applicable\)](#), and number of cores to be cut for density determination.

(e) [Paver Mounted Thermal Profiler base station or cellular reception plan with Global Navigation Satellite System \(GNSS\) accuracy and the QC contact person for data collection and processing.](#)

(f) A proposed independent third party name, contact, address, and phone number for dispute resolution.

**403.17.2.1 Third Party.** The third party shall be independent of the contractor, MoDOT consultants and all project subcontractors or suppliers on each specific project. All testing of material for dispute resolution shall be performed by an approved laboratory. Approved laboratories shall be AASHTO Accreditation Program certified in the areas of the material being tested.

**403.17.2.2 Plant Calibration.** Plant calibration shall be performed by the contractor in accordance with [Sec 404](#), and records shall be made available to the engineer.

**403.17.2.3 Retained Samples.** All samples taken by the contractor, including but not limited to tested aggregate, volumetric, [BMD loose mix](#) and density samples, shall be retained for the engineer for a minimum of seven days after the contractor's tests are complete and accepted unless otherwise instructed. These samples shall be maintained in clean covered containers, without contamination, readily accessible to the engineer. The retained sample's identification shall consist of, but is not limited to:

(a) Time and date sampled.

(b) Product specification number.

(c) Type of sample, i.e. belt, bin, stockpile.

(d) Lot and subplot designation.

(e) Sampler/Tester.

(f) Project Job Number.

**403.17.2.3.1 Gradation and Deleterious Content Samples.** For each gradation and deleterious sample taken, the contractor shall retain for the engineer, the portion of the sample not tested after reducing the original sample to testing size.

**403.17.2.3.2 Loose Mix Sample.** All loose mix samples for determination of volumetrics, asphalt binder content and TSR shall be taken either from the roadway or at the asphalt plant. Samples for BMD testing shall be taken from the asphalt plant. Sampling will be performed randomly at random locations as designated by the engineer. A companion loose mix sample shall be taken, identified and retained for the engineer.

**403.17.3 Quality Control Laboratory.** All QC mixture testing shall be performed in an approved laboratory.

**403.17.3.1 Calibration Schedule.** The contractor shall calibrate or verify all significant test equipment associated with tests covered in this specification. Intervals as set by the contractor shall not exceed the following limits:

Equipment - Test Method (AASHTO)	Requirement	Interval (Month)
Gyratory Compactor - T 312	Calibrate – 1.16 ± .02° internal angle	12 <sup>a</sup>
Gyratory Compactor - T 312	Verify	1 <sup>c</sup>
Gyratory Molds - T 312	Check Critical Dimensions	12
Thermometers - T 209, T 166, T 312	Calibrate	12
<a href="#">Hamburg Wheel Track – R 18</a>	<a href="#">Calibrate</a>	<a href="#">12</a>
<a href="#">Performance Testing Load Frames-R18</a>	<a href="#">Calibrate</a>	<a href="#">12</a>
<a href="#">Water Baths</a>	<a href="#">Verify Temperature</a>	<a href="#">12</a>
Vacuum System - T 209	Check Pressure	12
Pycnometer (Flask) - T 209	Calibrate	Daily
Binder Ignition Oven - T 308	Verify	12 <sup>b</sup>
Nuclear Content Gauge – T 287 or MoDOT TM 54	Drift & Stability – Manuf. Recommendation	1
Mechanical Shakers - T 27	Check Sieving Thoroughness	12
Sieves	Check Physical Condition	6
Weighted Foot Assembly - T 176	Check Weight	12
Mechanical Shaker - T 176	Check Rate & Length of Throw	12
Liquid Limit Device - T 89	Check Wear & Critical Dimensions	12
Grooving Tool - T 89	Check Critical Dimensions	12
Ovens	Verify Temp. Settings	12
Balances	Verify	12 <sup>b</sup>
Timers	Check Accuracy	12

<sup>a</sup>Calibrate and/or verify after each move.

<sup>b</sup>Verify after each move.

<sup>c</sup>Includes ram pressure, LVDT, frequency of gyration, and external angle.

**403.17.3.1.1 Inventory.** An inventory of all major sampling, testing, calibration and verification equipment, including the serial number or other identifying number shall be maintained.

**403.17.3.1.2 Calibration Records.** Calibration and verification records shall include but are not limited to:

- (a) Detailed results of the work performed (dimensions, mass, force, temperature, etc.)
- (b) Description of the equipment calibrated including identifying number.
- (c) Date the work was performed.
- (d) Identification of the individual performing the work.
- (e) Identification of the calibration or verification procedure used.
- (f) The previous calibration or verification date and next due date.
- (g) Identification of any in-house calibration or verification device used (including identification to establish traceability of items such as standard masses, proving rings, standard thermometers, balances, etc.).

**403.17.3.2 Record Retention.** Test records shall be maintained to permit verification of any test report. Records pertaining to testing, equipment calibration and verification, test reports, internal quality systems review, proficiency sample testing, test technician training and evaluation and personnel shall be retained in a secure location for a minimum of three years.

**403.17.3.3 Test Method Availability.** A current copy of all test methods and procedures shall be maintained in the QC laboratory at all times for reference by the technicians. Examples of report formats and procedures may be found in AASHTO R 18.

**403.18 Quality Assurance.** All QA field inspection, sampling and testing will be performed by a qualified MoDOT technician. The QA inspector shall have free access to any and all testing equipment used by the mixture producer and any workbooks, records or control charts maintained by the mixture producer for the QC process. The QA inspector shall also have sufficient access to the plant grounds to assure compliance with the approved QC Plan.

**403.18.1 Assurance Testing.** The engineer will independently sample and test the mixture from [the location designated by the QC plan \(asphalt plant or from the roadway\)](#) at the frequency listed in [Sec 403.19.3](#). The independent sample will be of sufficient size to retain half for possible disputes. Further testing of this sample will be under the direction of the engineer. The retained portion of the QC samples for mixture properties, gradation, and deleterious content will be tested at a frequency no less than once per week. The engineer's test results, including all raw data, will be made available to the contractor when completed and no later than the next working day. [For BMD SP095 and SP125 mixtures sampled at the plant, the contractor shall assist the engineer in sampling and fabricating BMD test specimens at the frequency listed in the applicable portions of Sec 403.19.3. QA shall conduct independent BMD testing at the provided random tonnage.](#)

**403.18.2 Core Chain of Custody.** QA density cores shall be sealed in approved tamper-evident containers immediately after extraction in the presence of the engineer.

**403.18.3 Aggregate Comparison.** Comparison for aggregate will be considered favorable when the contractor's QC results and the engineer's QA test results of a retained sample compare within the following limits. [For BMD SP095 and SP125 mixtures, field testing requirements of aggregate consensus properties will be waived and conducted only as necessary to determine mix issues.](#)

**403.18.3.1 Gradation.** [Gradations shall apply to all asphalt mixtures.](#)

Sieve Size	Percentage Points
3/4 inch and larger	5.0
1/2 inch	5.0
3/8 inch	4.0
No. 4	4.0
No. 8	3.0
No. 10	3.0
No. 16	3.0
No. 20	3.0
No. 30	3.0
No. 40	2.0
No. 50	2.0
No. 100	2.0
No. 200	1.0

**403.18.3.2 Coarse Aggregate Angularity.** Angular particles shall be within 5 percentage points.

**403.18.3.3 Fine Aggregate Angularity.** Void content shall be within 2 percentage points.

**403.18.3.4 Sand Equivalent.** Sand equivalency shall be within 8 percentage points.

**403.18.3.5 Thin, Elongated Particles.** Flat, elongated particle content shall be within one percentage point.

**403.18.3.6 Deleterious.** The total and individual deleterious content shall not exceed the specification limits.

**403.18.4 Federal Highway Administration Requirements.** Performance and acceptance of QC/QA testing under these specifications shall not eliminate any FHWA requirements for acceptance of the material.

**403.19 Acceptance of Material.** Acceptance of bituminous mixture will be based on lots. Material will be sampled from [either the asphalt plant or the](#) roadway behind the paver in lots or sublots on a random basis through the use of a random number system and evaluated using a Quality Level Analysis (QLA). A QLA will determine payment based on a combination of the total PWL (PWL<sub>t</sub>) determined for each pay factor item for each lot of material produced.

**403.19.1 Random Numbers.** The engineer will generate random numbers.

**403.19.2 Lots.** [A lot shall consist of no more than 6,000 tons. The maximum subplot size shall be 1,000 tons and each lot shall contain no less than four \(4\) sublots. Sublots from incomplete lots shall be combined with the previous complete lot for determination of pay factors. When no previous lot exists, the mixture shall be treated in accordance with Sec 403.23.9.4.1. A new lot shall begin when the asphalt content of a mixture is adjusted in accordance with Sec 403.11, if there is an asphalt binder grade change, or an additive source change. The lot size shall be designated in the contractor's QC Plan. Each lot shall contain no less than four sublots and the maximum subplot size shall be 1,000 tons. The maximum lot size shall be 4,000 tons for determination of pay factors. Sublots from incomplete lots shall be combined with the previous complete lot for determination of pay factors. When no previous lot exists, the mixture shall be](#)

~~treated in accordance with Sec 403.23.7.4.1. A new lot shall begin when the asphalt content of a mixture is adjusted in accordance with Sec 403.11.~~

**403.19.3 Test and Pay Factor Items.** As a minimum, the contractor and engineer shall test in accordance with the following tables. Table 1 testing requirements shall apply to BMD SP095 and SP125 mixtures. Table 2 testing requirements shall apply to all non-BMD asphalt mixtures. The number of random tests per subplot may be increased per the contractor's QC plan. The QC plan shall state the test and testing frequency. All random tests shall be used in the pay factor determination. Where multiple test methods are allowed, the contractor shall designate the test method to be used in the QC Plan. Final payment will be based on the indicated pay factor items.

<u>Table 1 - Balance Mix Design for SP095 and SP125 Mixtures</u>				
<u>Tested Property</u>	<u>PWL Pay Factors</u>	<u>Test Method</u>	<u>Contractor Frequency</u>	<u>Engineer Frequency</u>
<u>Mat Density (% of theoretical maximum density)<sup>(a)</sup></u>	<u>Yes</u>	<u>MoDOT TM 41 or AASHTO T 166<sup>(d)</sup></u>	<u>1 Sample / Sublot; as needed for joints and shoulders</u>	<u>1 Sample / Lot</u>
<u>Asphalt content</u>	<u>Yes</u>	<u>AASHTO T 164, or MoDOT Test Method TM-54, or AASHTO T 287, or AASHTO T 308</u>	<u>1 / Sublot</u>	<u>1 / Lot</u>
<u>V<sub>a</sub>, N<sub>des</sub><sup>(b)</sup></u>	<u>Yes</u>	<u>AASHTO T 312 and R 35</u>	<u>1 / Sublot</u>	<u>1 / Lot</u>
<u>VMA, N<sub>des</sub><sup>(b)</sup></u>	<u>No</u>	<u>AASHTO T 312 and R 35</u>	<u>1 / Sublot</u>	<u>1 / Lot</u>
<u>CT<sub>index</sub><sup>(c)</sup></u>	<u>No</u>	<u>ASTM D 8225 @ 25 ± 0.5 °C</u>	<u>1 / 6,000 tons</u>	<u>1 / 12,000 tons</u>
<u>Unconfined Longitudinal Joint Density<sup>(a)</sup></u>	<u>No</u>	<u>MoDOT TM 41 or AASHTO T 166<sup>(d)</sup></u>	<u>1 Sample / Sublot</u>	<u>1 Sample / Lot</u>
<u>RT<sub>index</sub> or HWT</u>	<u>No</u>	<u>ASTM D 8360 / AASHTO T 324; @ 50 ± 1 °C</u>	<u>1 / 6,000 tons</u>	<u>1 / 12,000 tons</u>
<u>Moisture Susceptibility: TSR or HWT<sup>(c)</sup></u>	<u>No</u>	<u>AASHTO T 283 / MoDOT TM-100</u>	<u>1 / 12,000 tons</u>	<u>1 / 48,000 tons</u>
<u>Cold feed or hot bin gradation</u>	<u>No</u>	<u>AASHTO T 27</u>	<u>1 / 2 Sublots</u>	<u>1 / Lot</u>
<u>Mixture temperature</u>	<u>No</u>	<u>---</u>	<u>1 / Sublot</u>	<u>1 / Day</u>
<u>Temperature of Base and Air</u>	<u>No</u>	<u>---</u>	<u>As Needed</u>	<u>As Needed</u>

<sup>a</sup> Core samples shall consist of one core. Up to two additional cores may be obtained at the same offset within six feet of the randomly selected location. If more than one core is obtained, all cores shall be used and combined into one sample.

<sup>b</sup> Based on the average of a minimum of two compacted specimens.

<sup>c</sup> Payment will be based upon the table in Sec 403.23.7.

<sup>d</sup> AASTHO T 331 shall be required when absorptions of the specimens are greater than 2.0 percent and may be substituted for AASHTO T 166.

<sup>e</sup> HWT shall be used to evaluate moisture susceptibility for acceptance when other hard durable aggregates are used in lieu of either crushed porphyry or steel slag.

**Table 2 – Non-BMD Asphalt Mixtures**

Tested Property	Pay Factor	Test Method	Contractor Frequency	Engineer Frequency
Mixture temperature	No	----	1/Sublot	1/day
Temperature of base and air	No	----	As needed	As needed
Mat Density (% of theoretical maximum density) by contractor	Yes	MoDOT Test Method TM-41 or AASHTO T 166 <sup>e</sup>	1 Sample <sup>b</sup> /Sublot As needed for joints & shoulders.	1 Sample/ <del>Lot</del> 4 Sublots
Unconfined Joint Density	No	MoDOT Test Method TM-41 or AASHTO T 166 <sup>e</sup>	1 Sample <sup>b</sup> /Sublot	1 Sample/ <del>Lot</del> 4 Sublots
Cold feed or hot bin gradation and deleterious content	No	AASHTO T 27 and AASHTO T 11	1/2 Sublots	1/ <del>Lot</del> 4 Sublots
Ground shingles	No	AASHTO T 27	1/ <del>10,000</del> 12,000 tons with a minimum of 1/project	1/project
FAA, CAA, Clay Content and Thin, Elongated Particles from material sampled from the cold feed or hot bin	No	AASHTO T 304, ASTM D 5821, AASHTO T 176 and ASTM D 4791	1/ <del>10,000</del> 12,000 tons with a minimum of 1/project/mix type	1/project
Asphalt content	Yes	AASHTO T 164, or MoDOT Test Method TM-54, or AASHTO T 287, or AASHTO T 308	1/Sublot	1/ <del>Lot</del> 4 Sublots
Asphalt content of RAP	No	AASHTO T 164 <sup>d</sup>	1/4 Sublots	1/project
VMA @ N <sub>des</sub> gyrations	Yes <sup>a</sup>	AASHTO T 312 and R 35 <sup>e</sup>	1/Sublot	1/ <del>Lot</del> 4 Sublots
V <sub>a</sub> @ N <sub>des</sub> gyrations	Yes <sup>a</sup>	AASHTO T 312 and R 35 <sup>e</sup>	1/Sublot	1/ <del>Lot</del> 4 Sublots
VFA @ N <sub>des</sub> gyrations	No <sup>a</sup>	AASHTO T 312 and R 35 <sup>e</sup>	1/Sublot	1/ <del>Lot</del> 4 Sublots
Theo. max SG of the mixture	No	AASHTO T 209	1/Sublot	1/ <del>Lot</del> 4 Sublots
TSR of the in place mixture <sup>f</sup>	No <sup>c</sup>	AASHTO T 283	1/ <del>10,000</del> 12,000 Tons or fraction thereof	1/ <del>50,000</del> 48,000 Tons or 1/project combination

<sup>a</sup>Based on the average of a minimum of two compacted specimens.

<sup>b</sup> Core samples shall consist of one core. Up to two additional cores, ~~as stated in the QC Plan,~~ may be obtained at the same offset within ~~six feet~~<sup>one foot</sup> of the randomly selected location. If more than one core is obtained, all cores shall be combined into one sample.

<sup>c</sup> Payment will be based on the table in [Sec 403.23.5](#).

<sup>d</sup> Other methods may be approved by establishing correction factors for RAP from the same source.

<sup>e</sup> ~~AASHTO T 331 may be substituted for AASHTO T 166.~~ [AASHTO T 331 shall be required when absorption of the specimens are greater than 2.0 percent and may be substituted for AASHTO T 166.](#)

<sup>f</sup> [In addition to TSR testing, HWT shall be used to evaluate moisture susceptibility for acceptance when other hard durable aggregates are used in lieu of either crushed porphyry or steel slag.](#)

#### 403.19.3.1 Test Method Modification.

**403.19.3.1.1 Binder Ignition Modification.** Asphalt content determination in accordance with AASHTO T 308, Section 6.9.1 shall be modified by adding the following: If the calibration factor exceeds 1.0 percent, lower the test temperature to  $800 \pm 8$  F and repeat test. Use the calibration factor obtained at 800 F even if it exceeds 1.0 percent. If RAP is used, the binder ignition oven shall be calibrated in accordance with MoDOT Test Method TM 77. At the engineer's discretion, testing may be waived when production does not exceed 200 tons per day. The contractor shall certify the proper proportions of a previously proven mixture were used.

**403.19.3.1.2 Rice Test.** When the water absorption of any aggregate fraction is greater than 2.0 percent, the test method for determining theoretical maximum specific gravity, AASHTO T 209, shall be modified as follows: After completing the procedure in accordance with Section 9.5.1 or 9.5.2, drain water from the sample. To prevent loss of fine particles, decant the water through a paper towel held over the top of the container. Spread the sample before an electric fan to remove surface moisture. Weigh at 15-minute intervals, and when the loss in mass is less than 0.05 percent for this interval, the sample may be considered to be surface dry. This procedure requires about 2 hours and shall be accompanied by intermittent stirring of the sample. Break conglomerations of mixture by hand. Take care to prevent loss of particles of mixture. Calculate the specific gravity of the sample by substituting the final surface-dry mass for A in denominator of Equations 2 or 3.

**403.19.3.1.3 Mixture Bulk Specific Gravity.** Determining bulk specific gravity using paraffin-coated specimens, AASHTO T 275, shall not be used when required by AASHTO T 166. Alternate methods are AASHTO T 331 and ASTM D1188. The surface of specimens prepared for testing by these methods may have the surface texture removed by sawing a minimal amount. Specimens shall be securely held in a jig or other clamping device to eliminate distortion and retain a face parallel to the original surface. Measurements for lift thickness shall be made prior to sawing.

**403.19.3.1.4 BMD SP095 and SP125 Mix Sampling and Specimen Fabrication.** [BMD loose mix shall be sampled at the plant by the contractor during production in accordance with AASHTO R 97 and split to the appropriate size in accordance with AASHTO R 47. After QC has been notified of the random sample, the first truck shall be sampled as directed by the engineer. If the random number for multiple tests overlap, the contractor shall complete the first testing requirements and then immediately proceed with the second testing requirements.](#)

[The contractor shall wait 30 minutes after sampling loose mix before fabricating specimens for  \$CT\_{Index}\$ ,  \$RT\_{Index}\$ , and HWT \(including HWT moisture susceptibility\) testing. Loose mix temperatures shall not drop below the molding temperature. The 30 minutes shall start when all the material for the loose mix sample has been obtained and the time this occurs shall be](#)

recorded. All specimens shall be fabricated as soon as possible after the 30-minute delay. QC and QA samples shall be sampled and fabricated at separate random times.

The following table details the minimum number of specimens required for QC or QA testing:

<u>Test Method</u>	<u>Minimum Number of Specimens<sup>(c)</sup></u>
<u>Cracking Tolerance Index (CT<sub>Index</sub>);</u>	<u>5 Compacted Specimens</u>
<u>Rutting Tolerance Index (RT<sub>Index</sub>);<sup>(a,b)</sup></u>	<u>3 Compacted Specimens</u>
<u>Retained Loose Mix<sup>(c)</sup></u>	<u>125 lbs</u>
<u>% Asphalt Content</u>	<u>1 Sample</u>
<u>Theo. Max SG of mixture, Gmm</u>	<u>1 Sample</u>
<u>% Air Voids</u>	<u>2 Compacted Specimens</u>
<u>Retained Loose Mix<sup>(c)</sup></u>	<u>30 lbs</u>
<u>Tensile Strength Ratio (TSR)<sup>(d)</sup></u>	<u>250 lbs</u>

<sup>a</sup> Retained loose mix for Hamburg verification of mixture not meeting minimum RT<sub>Index</sub> thresholds.

<sup>b</sup> HWT may be used in lieu of the RT<sub>Index</sub> tests or a RT<sub>Index</sub> correlation. Four (4) compacted 62 ± 1 mm specimens shall be fabricated.

<sup>c</sup> Retain loose mix material for dispute resolution. The loose mix shall be stored in a climate-controlled environment.

<sup>d</sup> HWT may be used in lieu of TSR tests in accordance with MoDOT TM-100.

<sup>e</sup> Compacted test specimens shall be allowed to cool to 77 ± 5 F prior to determining the air void content. After sample fabrication, the samples shall be stored in a climate-controlled environment and tested within 7 days.

**403.19.3.1.5 Performance Test Reporting.** CT<sub>Index</sub> testing shall be performed on five compacted specimens. All five results shall be reported. The average CT<sub>Index</sub> shall be calculated after discarding the highest and lowest CT<sub>Index</sub> values. The average CT<sub>Index</sub> shall be used to determine acceptance. RT<sub>Index</sub> testing shall be performed on three compacted specimens and the average result used to determine acceptance. HWT testing shall be performed on four compacted specimens and the average result used to determine acceptance.

Compacted specimens for CT<sub>Index</sub>, RT<sub>Index</sub>, and HWT testing shall be selected at random.

After sample fabrication, the samples shall be stored in a climate-controlled environment and tested within 7 days from when the specimens were compacted.

Compaction temperature, times in and out of the oven, gyratory specimen weights and times, and sample identification shall be recorded.

#### **403.19.3.2 Miscellaneous Applications.**

**403.19.3.2.1 Small Quantities.** Small quantities are less than ~~4000-6000~~ tons for each separate mixture. This applies to individual projects, individual projects in combination contracts or projects with short discontinuous sections. The contractor has the option to use all testing frequencies in accordance with [Sec 403.19.3](#) or the following shall apply:

(a) A field laboratory will not be required for monitoring mixtures. All required QC and QA testing shall be performed in an approved laboratory.

(b) Performance Tests (CT<sub>Index</sub>, RT<sub>Index</sub>, HWT, and TSR) are not required for BMD SP095 and SP125 mixtures

~~(b)~~ (c) QC tests required in [Sec 403.19.3](#) shall be performed at a frequency of no less than one per day if production does not exceed ~~750-1000~~ tons and at a frequency of no less than two per day if production exceeds ~~750-1000~~ tons. Independent or retained sample QA tests shall be performed at least once per ~~project~~~~1500 tons~~, as indicated.

**403.19.3.2.2 Base Widening and Entrances.** For base widening mixture and entrance work, the following will apply:

(a) All base widening shall be constructed in accordance with [Sec 401.7](#) and subsections.

(b) The minimum density of these mixtures shall be attained as specified herein, except, compaction may be performed in accordance with [Sec 403.15.3](#).

**403.19.4 Dispute Resolution.** When there are significant discrepancies between the engineer's and the contractor's test results, dispute resolution procedures will be used.

**403.19.4.1 Cease Work.** The contractor's operations may be required to cease until the dispute is resolved if the test results indicate the mixture is subject to failure.

**403.19.4.2 Third Party Resolution.** The first step in dispute resolution will be to identify differences in procedures and correcting inappropriate procedures before moving to third party resolution. If that does not resolve the dispute, either the contractor or the engineer may request the approved QC Plan third party involvement. The recommendations of the approved third party shall be binding on both the engineer and contractor.

403.19.4.2.1 Dispute Resolution for BMD SP095 and SP125 Test Results. If QA and QC results for CT<sub>Index</sub> or RT<sub>Index</sub> do not compare favorably according to 403.23.9.1.2, the first step will be to identify differences in procedures, including specimen aging. If that does not resolve the dispute, the QA CT<sub>Index</sub> result shall be averaged with the QC CT<sub>Index</sub> result to determine pay. If RT<sub>Index</sub> results are in dispute, QC shall fabricate specimens for Hamburg testing in the presence of the Engineer using the retained loose mix material. Compacted specimens shall be submitted to a third-party laboratory for HWT testing. Third-party HWT results shall be used to determine acceptance.

**403.19.4.3 Third Party Payment.** The contractor shall be responsible for the cost associated with the third party testing and resolution if the final result indicates the engineer's test results were correct. Likewise the Commission will be responsible for the cost associated with the third party testing and resolution when the final result indicates the contractor's results were correct.

**403.19.4.4 Other Adjustments.** The contractor shall not be entitled to any additional payment for costs incurred due to use of the dispute resolution procedures such as, but not limited to,

those for delay, cessation of operations, costs to subcontractors, etc. The engineer may give consideration to adjustment of working days if warranted.

**403.20 Surface Smoothness.** The finish of the pavement surface shall be substantially free from waves or irregularities and shall be true to the established crown and grade. The pavement surface shall be thoroughly tested for smoothness by profiling or ~~straighedging~~ [straightedging](#) in accordance with [Sec 610](#).

#### **403.21 General Requirements.**

**403.21.1 Sequence of Operations.** To reduce inconvenience to the traveling public during widening or surfacing, the contractor will not be permitted to place any final surface course until the base widening, the leveling course and the binder course have been completed throughout the entire combination of sections, unless otherwise authorized by the engineer. The proper condition of the base widening, the leveling course and the binder course, at the time of placing the surface course, shall be the contractor's responsibility.

**403.21.2 Pavement Marking.** If the contractor's work has obliterated the existing pavement marking on resurfacing projects open to through traffic, the pavement marking shall be replaced in accordance with [Sec 620](#).

**403.21.3 Surfaced Approaches.** At locations designated in the contract or as specified by the engineer, approaches shall be primed in accordance with [Sec 408](#) and surfaced with Type SP125 asphaltic concrete. The asphaltic concrete surface shall be placed in accordance with the details shown on the plans or as specified by the engineer. Approaches shall not be surfaced until after the surface course adjacent to the entrance is completed. Any work required to condition and prepare the subgrade on the approaches will be at the contractor's expense.

**403.21.4 Filling Drain Basins.** If shown on the plans, existing drain basins shall be filled to the top of the lip with plant mix bituminous base course or asphaltic concrete from the pavement edge to the edge of the shoulder. Any difficulty or delay created by this requirement will be at the contractor's expense.

**403.21.5 Pavement Repairs (Blow-Ups).** A blow-up will be considered that area where excessive expansion has resulted in distress to the existing pavement. Blow-ups occurring prior to the application of the tack coat on the existing surface will normally be repaired by the Commission. Blow-ups occurring after the application of the tack coat shall be repaired by the contractor by removing the distressed concrete and replacing the pavement in accordance with [Sec 613](#).

#### **403.22 Method of Measurement.**

**403.22.1 Weight Determination.** The weight of the mixture will be determined from the batch weights if a batch-type plant is used, and will be determined by weighing each truck load on scales in accordance with [Sec 310](#) if other types of plants are used. Measurement will be made to the nearest 0.1 ton for the total tonnage of material accepted.

#### **403.22.2 Full Depth.**

**403.22.2.1** The final driving surface area, for the full depth of the pavement, will be used as the area for all underlying bituminous lifts and will not include the additional quantity needed to construct the 1:1 slope.

**403.22.2.2** Final measurement of the completed pavement will not be made except for authorized changes during construction, or where appreciable errors are found in the contract quantity. Where required, measurement of the pavement complete in place will be made to the nearest 0.1 square yard. The revision or correction will be computed and added to or deducted from the contract quantity.

#### **403.22.3 Alternate Overlay.**

**403.22.3.1 Field Established Quantity.** When bid as an alternate to a Portland cement concrete overlay, the contractor shall establish the existing roadway profile and set the final overlay profile. The engineer may adjust the final profile as needed. The tons of hot mix asphalt required will be determined by the engineer from the set or adjusted profile. This quantity will be the field established plan quantity.

**403.22.3.2 Overlay Measurement.** Final measurement of the completed pavement will be based on the field established plan quantity except for authorized changes during construction. The revision or correction will be computed and added to or deducted from the contract quantity. Measurement of the pavement complete in place will be made to the nearest 0.1 ton.

**403.22.4 Pavement Testing.** The finished courses shall have the nominal thickness shown on the plans. Tests will be conducted to ensure that each course is being constructed to proper thickness, composition and density. The contractor shall cut samples from any layer of the compacted mixture at locations designated by the engineer. QA samples shall be cut and delivered to the engineer no later than the end of the next day following the laydown operation. If the samples are not cut and delivered as stated, the asphaltic laydown operation may be suspended and a deduction of 5 percent per day of the contract unit price of the representative material may be applied, until samples are cut and delivered to the engineer. Samples may be obtained by either sawing or drilling 4-inch minimum diameter cores. Each sawed sample shall consist of a single piece of the pavement of the size designated by the engineer, but no larger than 12 inches square.

**403.22.4.1 Pavement Thickness.** Lift thickness may be determined by the average thickness of cores taken for density measurements for each lot. Total thickness samples for new full depth asphalt pavements shall be obtained after all bituminous construction is completed on the project and shall be taken at locations specified by the engineer. For the purpose of determining the constructed thickness of full depth pavement, cores shall be taken at random intervals in each traffic lane at the rate of one core per 1000 feet or increment thereof, or at any other locations as may be determined by the engineer and measured in accordance with AASHTO T 148. Sections of any asphaltic concrete determined to be 0.5 inches or more, less than the thickness shown on the plans, shall be corrected by the contractor. No payment will be made for any costs incurred by the contractor in correcting pavement deficient in thickness. Each core is representative of the pavement thickness for a distance extending one-half the distance to the next core, measured along centerline, or in the case of a beginning or ending core, the distance will extend to the end of the pavement.

**403.22.4.2 Surface Restoration.** The surface from which samples have been taken, including those for density measurements, shall be restored by the contractor with the mixture then being produced no later than the next day of plant operation, if construction is still active. If bituminous construction has been completed, the surface from which samples have been taken shall be restored within 48 hours with an approved commercial mixture or with cold patch mixtures acceptable to the engineer.

#### **403.23 Basis of Payment.**

**403.23.1 Aggregate Variation.** Due to possible variations in the specific gravity of the aggregates, the tonnage of mixture used may vary from the proposal quantities. No adjustment in contract unit price will be made because of such variation.

**403.23.2 Compacted Samples.** Payment for obtaining and delivering samples of compacted mixture from the pavement and replacing the surface [for QA testing, or any additional tests as directed by the engineer](#), will be made per sample at the fixed price specified in [Sec 109](#). No direct payment will be made for samples taken for QC testing.

**403.23.3 Payment for Pavement Repairs (Blow-ups).** Payment for repairing blow-ups will be made in accordance with [Sec 104](#).

**403.23.4 Smoothness Adjustment.** The contract unit price for all mixes, except wedge or level course, will be adjusted in accordance with [Sec 610.5](#). The contract unit prices for asphaltic concrete pavement will be considered full compensation for all materials entering into the construction of the pavement and for the cost of the smoothness testing and correction.

**403.23.5 Tensile Strength Retained Adjustment [for non-BMD Mixtures](#).** The contract unit price of each ~~40,000~~ [12,000](#) tons or fraction thereof for all mixtures, [except BMD SP095 and SP125 mixtures](#), shall be adjusted based on TSR according to the following:

TSR	Percent of Contract Price
<del>Greater than 85% and above</del> <a href="#">Greater than 90% and above</a>	103
<del>80-85%</del> <a href="#">75-89%</a>	100
<del>70-74%</del>	98
<del>70-79%</del> <a href="#">65-69%</a>	97
<del>&lt;70%</del> <a href="#">65%</a>	Remove

**403.23.5.1 Moisture Susceptibility Requirements for BMD SP095 and SP125 Mixtures.** [No TSR price adjustment shall be provided for BMD SP095 and SP125 mixtures.](#)

**403.23.6 Unconfined Longitudinal Joint Density Adjustment.** [The minimum density of all traveled way pavement within 6 inches of a longitudinal joint, including the pavement on the traveled way side of the shoulder joint, shall not be less than 90.5 percent of the theoretical maximum specific gravity for all dense graded SuperPave mixtures and shall not be less than 92.0 percent of the theoretical maximum specific gravity for SMA mixtures. The density of the longitudinal joint when confined will be included in the evaluation of the remainder of the mat.](#) Pay adjustments due to longitudinal joint density will apply to the full width of the lane paved. The average of joint cores from each [sublot](#) will determine specification compliance. ~~Adjustments will be in accordance with Sec 403.23.7.4.1(b). If payment reductions are necessary, the lower adjusted contract unit price of the PWL or unconfined joint density adjustment will apply. Adjustments due to joint density will apply to the lot from which the cores are obtained. If payment reductions are necessary, the lowest PF<sub>Total</sub> shall apply.~~ [Adjustments due to unconfined longitudinal joint density will be in accordance with the following table and apply to the subplot from which the core\(s\) are obtained.](#)

<b>Unconfined Longitudinal Joint Density</b>	
<u>Field Density (Percent of Laboratory Max. Theoretical Specific Gravity)</u>	<u>Percent of Contract Unit Price</u>
<u>SuperPave Mixtures</u>	
<u>&gt;90.5</u>	<u>PF<sub>Total</sub> not changed by longitudinal joint density</u>
<u>89.5–90.4</u>	<u>Maximum PF<sub>Total</sub> = 100%; Correction Required<sup>(a)</sup></u>
<u>&lt;89.5</u>	<u>Remove and Replace</u>
<u>SMA Mixtures</u>	
<u>&gt;92.0</u>	<u>PF<sub>Total</sub> not changed by longitudinal joint density</u>
<u>90.0–91.9</u>	<u>Maximum PF<sub>Total</sub> = 100%; Correction Required<sup>(a)</sup></u>
<u>&lt;90.0</u>	<u>Remove and Replace</u>

<sup>a</sup> Correction requires spraying rapid penetrating emulsion on deficient density areas in accordance with JSP2303. All costs associated with correction shall be at the contractor's expense with no additional payment.

**403.23.6.1 Rapid Penetrating Emulsion.** Should use of Rapid Penetrating Emulsion (RPE) be necessary for corrective action of longitudinal joint density, RPE shall be in accordance with MoDOT JSP2303 Rapid Penetrating Emulsion (available at: [https://epg.modot.org/index.php/Job\\_Special\\_Provisions](https://epg.modot.org/index.php/Job_Special_Provisions)), except that no payment will be made for use of RPE.

**403.23.7 CT<sub>Index</sub> Adjustment for BMD SP095 and SP125 Mixtures.** The contract unit price for each 6,000 tons or fraction thereof for BMD mixtures shall be adjusted based on the average CT<sub>Index</sub> results for the tonnage according to the following table provided that acceptable stability and moisture susceptibility results are obtained. The lower adjusted contract unit price from the CT<sub>Index</sub> and TSR results shall apply. HWT stability and moisture susceptibility results shall be implemented as a pass/fail basis.

<b>BMD SP095 and SP125 SuperPave Mixtures</b>		
<u>Cracking Tolerance Index (CT<sub>Index</sub>)</u>	<u>Tensile Strength Ratio (TSR)</u>	<u>Percent of Contract Price <sup>(a)</sup></u>
<u>100 or Greater</u>	<u>Greater than 85%<sup>(b)(c)</sup></u>	<u>103%</u>
<u>50–99</u>	<u>80–85%</u>	<u>100%</u>
<u>40–49</u>	<u>70–79%</u>	<u>97%</u>

<sup>a</sup> The CT<sub>Index</sub> adjustment only applies if the RT<sub>Index</sub> or HWT results meet the specification.

<sup>b</sup> The HWT moisture susceptibility testing may be used in lieu of TSR in accordance with MoDOT TM-100. Passing HWT results will equate to a TSR greater than 85 percent.

<sup>c</sup> If an approved liquid anti-strip is used, the TSR shall be greater than or equal to 80 percent to receive full incentive.

**403.23.7.1 Stability Requirements for BMD SP095 and SP125 Mixtures.** BMD asphalt mixtures shall pass the stability requirements with a passing RT<sub>Index</sub> or HWT rut depth criteria in accordance with Sec 403.5.11.2 to receive CT<sub>Index</sub> incentives.

**403.23.7.2 Moisture Susceptibility Requirements for BMD SP095 and SP125 Mixtures.** BMD asphalt mixtures shall either meet the above TSR requirements or meet the HWT moisture susceptibility requirements in accordance with Sec 403.5.11.3 to receive CT<sub>Index</sub> incentives.

**403.23.8 Paver Mounted Thermal Profiler Adjustments for BMD SP095 and SP125 Mixtures.** The contract unit price for all BMD mixes will be adjusted in accordance with Sec 406. The contract unit prices for asphaltic concrete pavement will be considered full compensation for all materials entering into the construction of the pavement and for the cost of the PMTP testing and correction.

**403.23.97 Percent Within Limits.** PWL will be based on the mean, standard deviation and quality index of each lot's test results for density, percent asphalt, percent air voids, and VMA (VMA not applicable to BMD mixtures). The upper PWL (PWL<sub>u</sub>) and lower PWL (PWL<sub>l</sub>) is determined from the table in Sec 502.15.8. Total percent within limits, PWL<sub>t</sub>, is: PWL<sub>t</sub> = (PWL<sub>u</sub> + PWL<sub>l</sub>) - 100.

The mean is:  $x_a = (\sum x_j)/n$

Where:  $x_a$  = Average of the individual values being considered

$\sum x_j$  = The summation of all the individual values being considered

n = The number of individual values under consideration

The Standard Deviation is:  $s = (\sum(x_i - x_a)^2/(n - 1))^{1/2}$

The Upper Quality Index is:  $Q_u = (USL - x_a)/s$

The Lower Quality Index is:  $Q_l = (x_a - LSL)/s$

Where:  $Q_u$  = Upper Quality Index

$Q_l$  = Lower Quality Index

USL = Pay Factor Item Upper Spec Limit

LSL = Pay Factor Item Lower Spec Limit

**403.23.9.17-1 Quality Level Analysis.** The engineer will make the QLA no more than 24 hours after receipt of the contractor's test results, by determining the PWL<sub>t</sub> for each designated pay factor item.

**403.23.9.1.17-1.1 Acceptance.** The contractor's test results will be used when applicable to determine the PWL, provided the contractor's QC tests and the engineer's QA tests compare favorably, and provided the engineer's inspection and monitoring activities indicate the contractor is following the approved QC Plan.

**403.23.9.1.27-1.2 Comparison.** Favorable comparison will be obtained when the engineer's QA test results on a production sample are within two standard deviations, or ~~one-half the specification-the comparison~~ tolerance, whichever is greater, from the mean of the contractor's test results for that particular lot. Comparison tolerances shall be as follows: air voids within ±0.5 percent, asphalt content within ±0.2 percent, density within ±1.3 percent, and, if applicable, VMA within ±1.25 percent (VMA not applicable to BMD Mixtures).

For BMD SP095 and SP125 mixtures, QA CT<sub>Index</sub> results shall be within ± 30 of the nearest QC test result. For the CT<sub>Index</sub> test, if all QC and QA are greater than 80, then results are considered comparable. QA RT<sub>Index</sub> results shall be within ±15 percent of the nearest QC test result. QC and QA RT<sub>Index</sub> results shall be considered to compare favorably if both QC and QA RT<sub>Index</sub> results meet specification requirements. QC and QA HWT results shall be considered to compare favorably if both QC and QA HWT results meet specification requirements. Further

comparisons may be made by using F & t testing at a significance level of 1 percent as directed by the engineer.

**403.23.9.1.3~~7.1.3~~ Outliers.** No test result shall be discarded, except individual test results on a lot basis may be checked for an outlier in accordance with the statistic T in ASTM E 178, at a significance level of 5 percent. If an outlier is found, material from the retained QA sample may be tested, in the presence of the engineer, to determine a replacement test value. The replacement test value shall be used in the PWL determination.

**403.23.9.1.4~~7.1.4~~ Roadway/Shoulder Lots.** For the purpose of QLA, mixture placed on the traveled way and placed on the traveled way and shoulders integrally, shall be accounted for in a regular lot/sublot routine. Mixture placed on shoulders only shall be accounted for in a shoulder lot/sublot routine.

**403.23.9.1.5~~7.1.5~~ Random Sampling.** For the purpose of QLA, all mixture placed on the roadway shall be subject to random testing, except mixture placed within 6 inches of an unconfined longitudinal joint shall not be subject to evaluation. Random samples taken in the same day may be separated by 200 tons.

**403.23.9.2~~7.2~~ Pay Factors.**

**403.23.9.2.1 Pay Factors for non-BMD Mixtures (SP048, SP190, SP250, and SMA).** The total pay factor (PF<sub>T</sub>) for each lot for non-BMD mixtures will be equal to the weighted sum of the pay factors (PF) for each pay factor item for each lot, and is determined as follows:

$$PF_T = + (0.25) PF_{\text{density}} + (0.25) PF_{AC} + (0.25) PF_{VMA} + (0.25) PF_{Va}$$

The PF<sub>T</sub> for each lot, on the shoulder or otherwise when the density pay factor is not directly included, will be equal to the weighted sum of the PF for each pay factor item for each lot, and will be determined as follows:

$$PF_T = + (0.3333) PF_{AC} + (0.3333) PF_{VMA} + (0.3333) PF_{Va}$$

The PF for each pay factor item for each lot will be based on the PWL<sub>t</sub> of each pay factor item of each lot and will be determined as follows:

$$\text{When } PWL_t \text{ is greater than or equal to } 70: PF = 0.5 PWL_t + 55$$

$$\text{When } PWL_t \text{ is less than } 70: PF = 2 PWL_t - 50$$

**403.23.9.2.2 Pay Factors for BMD SP095 and SP125 Mixtures.** The total pay factor (PF<sub>T</sub>) for each lot for BMD SP095 and SP125 mixtures will be equal to the weighted sum of the pay factors (PF) for each pay factor item for each lot, and is determined as follows:

$$PF_T = + (0.5) PF_{\text{Density}} + (0.25) PF_{Va} + (0.25) PF_{AC}$$

The PF<sub>T</sub> for each lot, on the shoulder or otherwise when the density pay factor is not directly included, will be equal to the weighted sum of the PF for each pay factor item for each lot, and will be determined as follows:

$$PF_T = (0.5) PF_{Va} + (0.5) PF_{AC}$$

The PF for each pay factor item for each lot will be based on the PWL<sub>t</sub> of each pay factor item of each lot and will be determined as follows:

$$\text{When } PWL_t \text{ is greater than or equal to } 90: PF = 0.3 PWL_t + 73;$$

When  $PWL_t$  is greater than or equal to 70 and  $PWL_t$  is less than 90:  $PF = 0.5 PWL_t + 55$ ;

When  $PWL_t$  is less than 70:  $PF = 2 PWL_t - 50$ ;

**403.23.9.2.3~~7.2.1~~ Density Pay Factor.** The theoretical maximum specific gravity of the mixture, as determined for each subplot and the bulk specific gravity of no less than one core from each subplot, will be used to perform the QLA for the percent of theoretical maximum density. Thick cores required to be cut in half in accordance with [Sec 403.15.4](#) shall effectively double the number of sublots for cores. When density is not used as a pay factor, additional adjustment of the contract unit price will be based on the table in [Sec 403.23.9.4.1\(d\)~~7.4.1\(b\)~~](#).

**403.23.9.2.4~~7.2.2~~ Asphalt Content Pay Factor.** The QLA will be performed using the asphalt content test results from each lot.

**403.23.9.2.5~~7.2.3~~ Voids in the Mineral Aggregate (VMA not applicable for BMD Mixtures) and Air Voids Pay Factor.** Two gyratory specimens shall be compacted for each subplot and the average of the two specimens will be used to calculate the volumetrics of the subplot. The VMA, VFA, and air voids shall be determined from the gyratory compacted specimens. The VMA and air voids for the QLA shall be those calculated using the combined bulk specific gravity of the aggregate as listed on the approved job mix formula, the average bulk specific gravity of the gyratory compacted specimens and the theoretical maximum specific gravity of the mixture determined for the subplot of material. The aggregate content used for the calculation shall be that determined from field asphalt content testing for that subplot.

**403.23.9.3~~7.3~~ Removal of Material.** All lots of material with a  $PF_T$  less than 50.0 shall be removed and replaced with acceptable material by the contractor.

Any subplot of material with a percent of theoretical maximum density of less than ~~90.5~~~~90.0~~ percent or greater than ~~98.5~~~~98.0~~ percent shall be removed and replaced with acceptable material by the contractor. For SMA mixtures, any subplot of material with a percent of theoretical maximum density of less than 92.0 percent shall be removed and replaced with acceptable material by the contractor.

Any subplot of ~~non-SMA mixtures~~material with air voids in the compacted specimens less than ~~1.5~~~~2.5~~ percent shall be removed and replaced with acceptable material by the contractor. Any subplot of SMA mixtures with air voids in compacted specimens less than 2.5 percent shall be removed and replaced with acceptable material by the contractor.

Any material with TSR results below 70 percent or material not meeting MoDOT TM-100 requirements from the HWT shall be removed and replaced with acceptable material by the contractor.

For BMD SP095 and SP125 mixtures, any lots of material with a rut depth greater than 12.5 mm of rutting at the designated number of wheel passes for the contract binder grade shall be removed and replaced with acceptable material by the contractor.

For BMD SP095 and SP125 mixtures, any lots of material with a  $CT_{Index}$  less than 40 shall be removed and replaced with acceptable material by the contractor.

No additional payment will be made for such removal and replacement. The replaced material will be tested at the frequencies listed in [the applicable portions of Sec 403.19](#). Pay for the material will be determined in accordance with the applicable portions of [Sec 403.23](#) based on the replacement material.

**403.23.9.4.7.4 Miscellaneous Applications.**

**403.23.9.4.1.7.4.1 Small Quantities.** Small quantities are defined in [Sec 403.19.3.2.1](#). Unless the contractor has elected to use the normal evaluation in the Bituminous QC Plan for small quantities, the following shall apply for each separate mixture qualifying as a small quantity.

(a) [For non-BMD asphalt mixtures, QLA and PWL shall not apply. For TSR incentive/disincentive to apply to non-BMD mixtures, the Bituminous QC plan shall require TSR testing. Price adjustments shall be in accordance with Sec 403.23.5.](#)

(b) [For BMD asphalt mixtures QLA and PWL shall not apply. CT<sub>Index</sub> and RT<sub>Index</sub> tests are not required for BMD SP095 and SP125 mixtures. A three \(3\) percent of the contract unit price incentive shall be provided for BMD SP095 and SP125 mixtures that meet the HWT stability and moisture susceptibility requirements in accordance with Sec 403.5.11.2 and Sec 403.5.11.3. For the moisture susceptibility incentive to apply, the Bituminous QC plan shall require HWT stability and moisture susceptibility testing.](#)

(bc) ~~Mixtures-All mixtures~~ shall be within the specified limits for VMA, V<sub>a</sub>, AC and density. In addition to any adjustments in pay due to profile, the contract unit price for the mixture represented by each set of cores will be adjusted based on actual field density above or below the specified density using the following schedule:

<b>Field Density (Percent of Laboratory Max. Theoretical Density)</b>		<b>Pay Factor (Percent of Contract Unit Price)</b>
<b>For all SP mixtures other than SMA:</b>		
		92.0 to 97.0 inclusive
97.1 to 97.5	or	91.5 to 91.9 inclusive
	or	91.0 to 91.4 inclusive
97.6 to 98.0	or	90.5 to 90.9 inclusive
	or	90.0 to 90.4 inclusive
-Above 98.0	or	Below 90.0
		<b>Remove and Replace</b>
<b>For SMA mixtures:</b>		
		>94.0
		93.5 to 93.9 inclusive
		93.0 to 93.4 inclusive
		92.5 to 92.9 inclusive
		92.0 to 92.4 inclusive
		Below 92.0
		<b>Remove and Replace</b>

<u>Field Density (Percent of Laboratory Max. Theoretical Density)</u>	<u>Pav Factor (Percent of Contract Unit Price)</u>
<b><u>For all SP mixtures other than SMA:</u></b>	
<u>92.5 to 98.5 inclusive</u>	<u>100</u>
<u>90.5 to 92.4 inclusive</u>	<u>Correction<sup>(a)</sup></u>
<u>Above 98.5 or Below 90.5</u>	<u>Remove and Replace</u>
<b><u>For SMA mixtures:</u></b>	
<u>&gt;94.0</u>	<u>100</u>
<u>92.0 to 93.9 inclusive</u>	<u>Correction<sup>(a)</sup></u>
<u>Above 98.5 or Below 92.0</u>	<u>Remove and Replace</u>

<sup>a</sup> Correction requires spraying rapid penetrating emulsion on deficient density areas in accordance with JSP2303. All costs associated with correction shall be at the contractor's expense with no additional payment.

**403.23.9.4.2~~7.4.2~~ Base Widening and Entrances.** For base widening mixtures and entrance work, BMD testing, QLA and PWL will not be required. Payment for these mixtures will be made at 100 percent of contract unit price for material that otherwise meets the specifications.

**403.23.9.4.3~~7.4.3~~ Single Lift on Unmilled Surface or Leveling Course Work.** For resurfacing projects specifying a single lift on an unmilled surface, surface mixture of 3,000 tons or more, or for leveling course work, the following shall apply to the traveled way mixture. All bituminous mixture QC/QA requirements shall apply, except the density pay factor designated in Sec 403.23.9.2~~7.2~~ will not be directly included in the total pay factor. In lieu of that, one density sample shall be taken per subplot and the pay adjustment for density will be made using the table in Sec 403.23.9.4.1(d)~~7.4.1(b)~~.



## SECTION 406

### PAVER-MOUNTED THERMAL PROFILES

**406.1 Description.** This work shall consist of continuous thermal profiling of the asphalt mat temperature behind the trailing edge of the paver screed plate during placement operations using a Paver-Mounted Thermal Profile System (PMTPS). This work shall be completed in accordance with the general principles set forth in AASHTO R 110 "Standard Practice for Continuous Thermal Profile of Asphalt Mixture Construction", and specifically as stated in the following sections.

**406.2 Required Measurements.** PMTPS measurements are required on the full width of paving of each asphalt lift required by Sec 403. Collection of data shall include shoulder pavement when placed simultaneously with the mainline. The shoulder paving data will be filtered out using Veta during data processing. PMTPS data collection is not required in the following exceptions:

- (1) PMTPS measurements are not required on auxiliary lane tapers, ramps, shoulders (not paved simultaneously with mainline), cross-overs, non-continuous turn lanes, loops, bypass lanes, acceleration/deceleration lanes, intersecting streets, roundabouts, and partial lane width widenings.
- (2) PMTPS measurements are not required for a total net paving length less than 2 lane miles.
- (3) PMTPS measurements are not required on asphalt lift thicknesses less than 1 inch.

**406.3 Equipment Requirements.** The PMTPS shall consist of the following components listed.

- (1) Temperature sensor to continuously monitor surface temperature of mat.
  - (a) Longitudinal and lateral surface temperature readings shall be collected at 12-inch or less intervals at all paving speeds with an X-Y accuracy of plus or minus 1 inch.
  - (b) Surface temperatures shall be collected for the full width paved in one pass (including any shoulders paved simultaneously with mainline).
  - (c) Surface temperature sensors(s) shall have a temperature range of at least 140 F to 480 F. Sensory accuracy shall be plus or minus 3.6 F, or plus or minus 2.0 percent of sensor reading, whichever is greater.
- (2) Global Navigation Satellite System (GNSS) receiver to capture coordinates of the surface temperature readings. GNSS accuracy shall be plus or minus 2 inches or less in X and Y directions when intelligent compaction is being used. A base station shall be required at any locations having poor cellular reception to obtain required accuracy. When intelligent compaction is not being used GNSS accuracy shall be plus or minus 4 feet or less in the X and Y directions and ground distance sensor shall be within plus or minus 1/1000 feet.

- (3) Onboard data acquisition with a minimum of the following capabilities:
  - (a) Displays (in real-time) map of the surface temperature readings.
  - (b) Displays total distance, paver speed and location.
  - (c) Reports surface temperature readings and GNSS status.
  - (d) Provides real-time statistical summaries of surface temperature readings.
  - (e) Allows operator to define data lot currently being placed per AASHTO PP 114.
  - (f) Stores data internally until data transfer.
  - (g) Automatically transfers data to cloud storage or other approved methods.

**406.3.1 System Setup on Pavers.** Pavers shall be instrumented with the PMTP system for the full paving width and shall collect measurements no less than 3 feet and no greater than 12 feet from the trailing edge of the screed plate. Other objects shall not obstruct surface temperature measurements and GNSS accuracy.

#### **406.4 Construction Requirements.**

**406.4.1 Temperature Verification.** Temperature verification shall follow AASHTO R110-22, Section 6 Calibration. A record of each verification shall be submitted to the SharePoint site prior to the start of the project.

**406.4.2 Data Management.** PMTP data files shall be compatible with the Veta software. The contractor shall supply the engineer with the manufacturer's PMTPS Computer Software 14 days prior to beginning work and until ninety days after completion of all work. If Cloud Storage or Cloud Computing is used, the engineer shall be supplied one user ID with full access for the same time-period specified. If cloud storage is not used Raw PMTP data files shall be downloaded once per day and uploaded to the appropriate MoDOT IC-PMTP SharePoint site before the start of the next day's production. The following data management requirements shall apply:

- (1) The PMTP data files should be directly transferred from cloud storage to Veta. Other methods shall be approved by the engineer.
- (2) The PMTP Veta files shall be appropriately formatted and filtered in accordance with MoDOT IC-PMTP protocol.
- (3) Date and time stamp of PMTP shall be checked and verified to reflect the local time zone for both mapped and exported data.

**406.4.3 Quality Control.** The following shall apply to the Contractor's Quality Control for PMTP.

- (1) The contractor shall have a properly trained person listed in the QC Plan that has completed a Veta training course within the last 2 years to perform the PMTP data collection and file management for the project.

- (2) The PMTP system shall have a documented annual calibration before beginning construction.
- (3) For each run, the thermal profile shall be divided into 150-foot sublots at the full paving width and partial data sublots as follows:
  - (a) Combine partial data sublots less than 75 feet with the previous data subplot.
  - (b) Treat partial sublots greater than 75 feet as one data subplot.
  - (c) Sublots shall not extend over multiple days, different lifts, or paving directions.
- (4) Veta files shall be completed and uploaded with the appropriate naming convention in accordance with MoDOT IC-PMTPS Protocol. Appropriate naming convention can be found in the IC-PMTP Document Helper. The completed Veta files shall have the appropriate filters applied with the summary data transferred to the Summary Report. An up-to-date Summary Report shall be provided to the engineer two days prior to the 1<sup>st</sup> and 15<sup>th</sup> of each month.
- (5) **PMTP Quality Control Plan.** A pre-activity meeting shall be required prior to mainline paving. The PMTP Quality Control Plan shall be submitted to the engineer at least 2 weeks prior to the mainline paving pre-activity meeting. The plan at minimum shall include the following:
  - (a) A list of personnel previously trained
  - (b) Detailed daily verification procedure for checking the RTK-GNSS of PMTP
  - (c) Procedure for downloading PMTP data from the instrument
  - (d) The procedure for training operators or other project staff
  - (e) Detailed daily verification procedure for checking the temperature sensor on the PMTP
  - (f) The name of the designated PMTP Quality Control Technician
  - (g) Procedure for submitting data
  - (h) Contact information for technical support staff
  - (i) Anticipated cellular service and GNSS coverage throughout entire project
  - (j) A list of the control points with either UTM or State Plane Coordinates established by the contractor if a base station is required.

**406.4.4 Quality Assurance (QA) Testing.** The engineer will use a Forward Looking InfraRed (FLIR) camera to verify the contractor's PMTP system. QA tests shall be taken at random locations twice per day. The contractor shall assist the engineer with the placement of the event marker.

The QA tests using the FLIR data QA tool shall compare favorably, according to the instructions found in the IC-PMTP Document Helper. If results do not compare favorably, the contractor's PMTPS shall be verified by the manufacturer. In the case that the PMTPS is required to be sent off to the manufacturer and the contractor is not able to provide a replacement, the contractor will be allowed to continue paving with the verification by the engineer using a FLIR camera for acceptance only.

**406.4.5 Thermal Segregation.** Thermal segregation will be calculated by using the Differential Range Statistics (DRS) under the parameters of AASHTO R110 in each 150-foot subplot.

The Veta analysis with the appropriate filters applied shall exclude the following surface temperature readings from each subplot:

- (1) Surface temperature readings less than 180 F.
- (2) Surface temperature readings within 2 feet. prior to and 8 feet. after paver stops that are greater than 1 minute in length.

The thermal segregation categories are based on the Differential Range Statistics (DRS), as shown in the table below.

Differential Range Statistics (DRS)	Thermal Segregation Category
$DRS \leq 25.0^{\circ}F$	Low
$25^{\circ}F < DRS \leq 35^{\circ}F$	Moderate
$35^{\circ}F < DRS \leq 50^{\circ}F$	Moderate-High
$DRS \geq 50^{\circ}F$	Severe

**406.4.6 Incentive/Disincentive.** Incentive/disincentive adjustments shall be made for each subplot in accordance with the following:

Thermal Segregation Category	Adjustment per 150 ft. Sublot
Low	\$40 Incentive
Moderate	\$40 to \$0 Incentive (Linear)
Moderate-High	\$0 to -\$40 Disincentive (Linear)
Severe	-\$40 Disincentive and Reviewed by Engineer

**406.5 Loss of Data.** If data collection ceases as a result of circumstances reasonably beyond the control of the contractor, the contractor will be allowed to continue the days paving, but the paved sublots will not be eligible for 406 PMTP Incentive. The engineer must be notified immediately of the issue and shall determine if the contractor has made a reasonable effort to resolve the issue. A meeting with the engineer shall be held to determine how to proceed if the issue is expected to extend into the next day's paving. Failure to notify the engineer of the issue at hand will result in the paved sublots to receive a minus \$40 deduct.

**406.5.1 GNSS Obstructions.** Isolated areas of GNSS obstruction may be filtered out of Veta at the contractor's choice. These areas shall be identified in Veta and brought to the attention of the engineer. Areas excluded from GPS obstruction shall not exceed approximately 5 percent of the total day's production. It is at the discretion of the engineer to determine if the area exceeds an approximate 5 percent.

**406.6 Basis of Payment.** No direct payment will be made for compliance with this provision.

## MoDOT TM-100 - Procedure to Calculate the Slope Ratio (SR) and Stripping Inflection Point (SIP) using the Hamburg Wheel-Track (HWT) Test

### 1. Run the HWT test in accordance with AASHTO T 324 at 50 +/- 1 ° C for 20,000 passes (regardless of the mix type and contract binder grade).

Record rut depth at each cycle or at regular cycle intervals during the test.

### 2. Plot the average rut depth versus number of cycles up to the 20,000 passes

Create a graph using Hamburg Test Data Analysis form that is available at MoDOT's "Forms for Contractor Use" page on MoDOT's website - [Forms for Contractor Use | Missouri Department of Transportation](#).

- **X-axis:** number of wheel passes or cycles
- **Y-axis:** rut depth in millimeters
- **Report the average rut depth at 20,000 passes for all asphalt mixtures:**

Binder Contract Grade <sup>(a)</sup>	Minimum Wheel Passes	Maximum Rut Depth (mm)
58-28H / 64-22	20,000	4 mm
64-22H / 70-22		
64-22V / 76-22		

- If the average rut depth at 20,000 passes is 4 mm or less, the mixture passes the HWT stripping test and no further analysis is needed. If the rut depth exceeds 4mm, continue with Steps 3 through 5.

### 3. Identify the two linear portions of the curve

Determine the two best-fit straight-line sections using a linear regression equation from excel spreadsheet or other graphing tools:

- **First portion:** steady-state rutting region before stripping begins
- **Second portion:** post-stripping region where rutting increases more rapidly

### 4. Calculate the slope of each portion

Use linear regression for each section:

- **Slope 1** = slope of the first portion – Creep Slope ( $M_1$ ) from linear regression equation –  $y = M_1x + b_1$

- **Slope 2** = slope of the second portion – Stripping Slope ( $M_2$ ) from linear regression equation –  $y_2 = M_2x + b_2$

### 5. Calculate the slope ratio

$$\text{Slope Ratio} = M_2 \div M_1$$

Where:

- **$M_1$**  = slope of the steady-state rutting portion
- **$M_2$**  = slope of the stripping portion

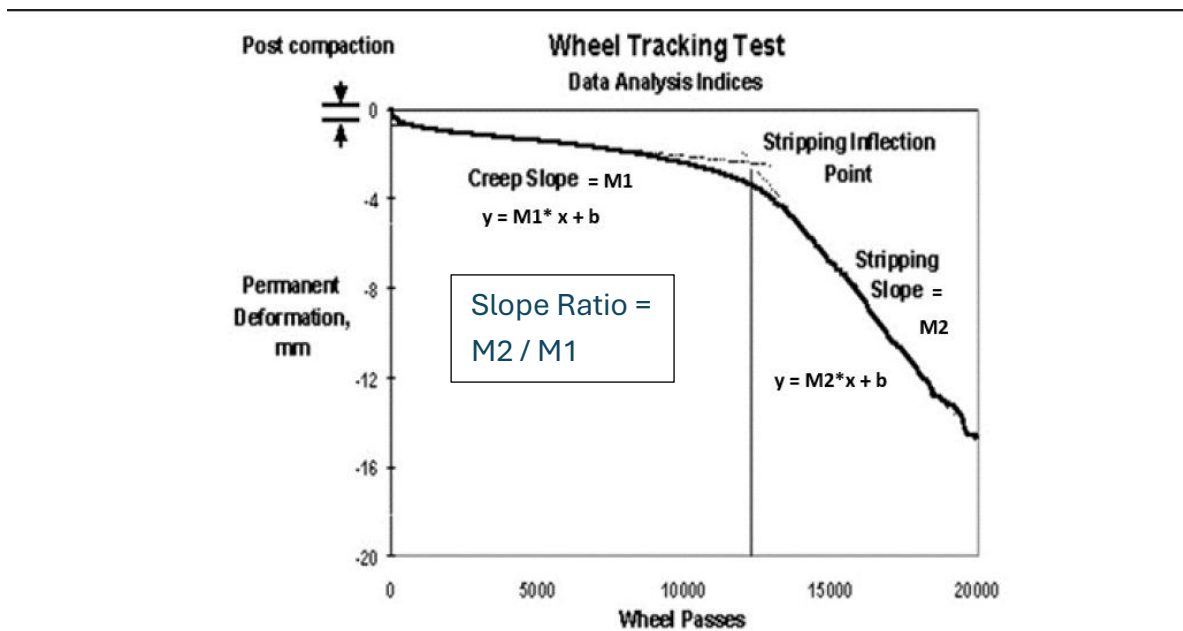

**Figure 1.1. Typical rut depth versus wheel passes data obtained from HWTT and computation of stripping parameters after (Cooley Jr et al., 2000)**

- If slope ration ( $M_2 / M_1$ ) is less than 2.0 from the two linear equations from the creep slope and stripping slope for 20,000 passes using HWT test, the mixture passes the HWT stripping test and no further analysis is needed. If the slope ration ( $M_2 / M_1$ ) is 2.0 or greater, continue with Step 6.

## 6. Calculate the stripping inflection point

Find the intersection of the two best-fit lines using linear regression equations determined from Steps 3 through 5.

If the first line is:

$$y = M_1x + b_1$$

and the second line is:

$$y = M_2x + b_2$$

then:

$$\text{SIP} = (b_2 - b_1) \div (M_1 - M_2)$$

Where:

- **b1** = intercept of the first portion
- **b2** = intercept of the second portion
- **M1** = slope of the first portion
- **M2** = slope of the second portion

If the stripping inflection point (SIP) is greater than 15,000 wheel passes, then the mixture passes the HWT stripping test and no further analysis is needed.

## 7. Interpret the Combined HWT Stripping Results

- A higher SIP generally indicates better resistance to moisture damage
- A lower slope ratio usually indicates less acceleration in rutting after stripping begins
- If no second slope is evident, the mix may not have shown stripping during the test
- If the SIP is 15,000 wheel passes or less, did not pass the 4 mm rut depth in Step 2, and did not pass the slope ratio (SR) of less than 2.0 in Steps 3 through 5, the mixture is unacceptable.

## EXAMPLE HWT Report

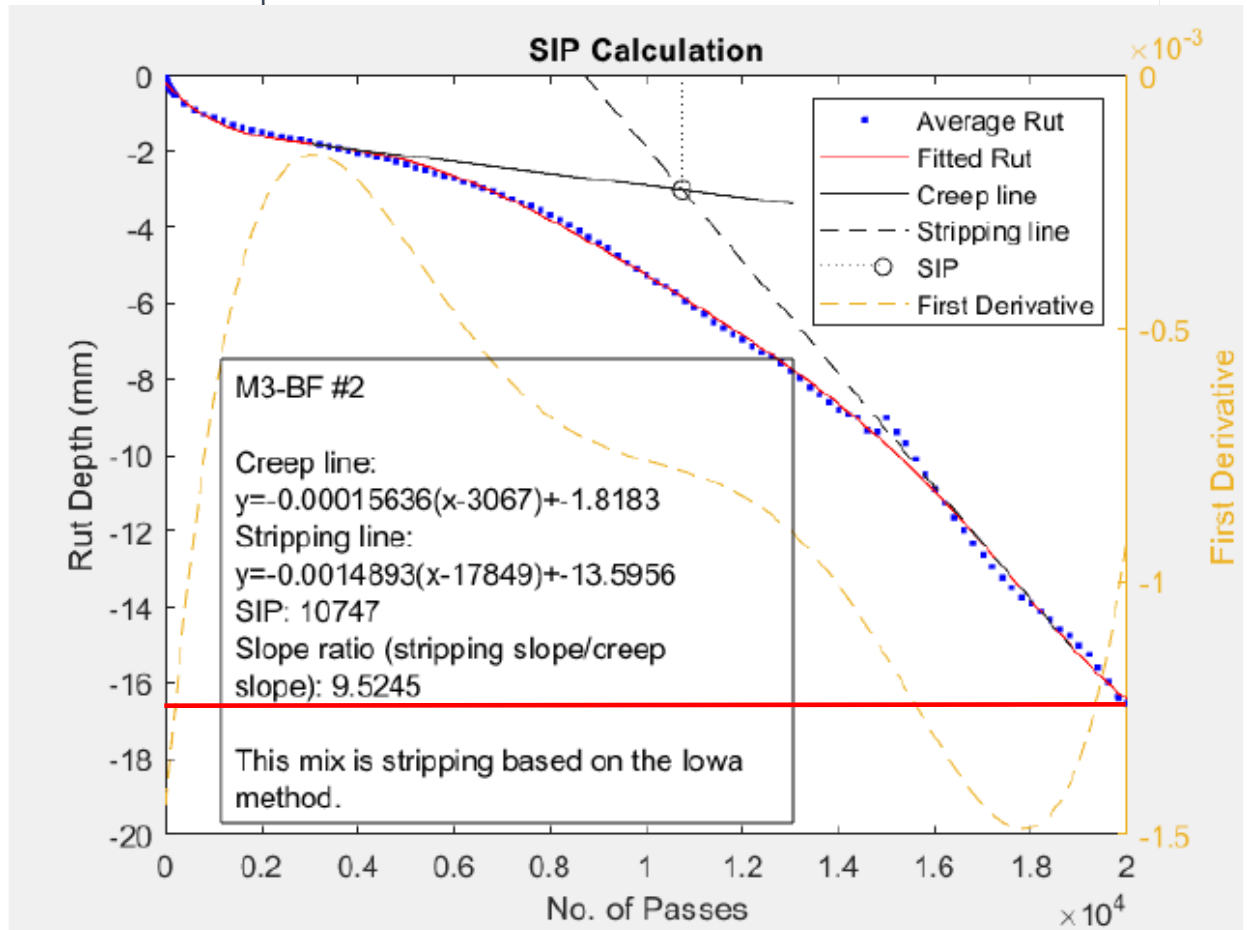

Rut depth at 20,000 Passes = 16.3 mm

Slope Ratio =  $M_2/M_1 = -0.0014893 / -0.00015636 = 9.52$

$SIP = (b_2 - b_1) \div (M_1 - M_2) =$

$b_2 = ((-0.0014893 \times -17849)) + (-13.5956) = 12.9869157$

$b_1 = ((0.00015636 \times -3067)) + (-1.8183) = -1.33874388$

$SIP = ((12.9869157 - (-1.33874388)) / ((-0.00015636) - (-0.0014893)) = 10,747$

With rutting greater than 4 mm, Slope Ratio greater than 2.0, and SIP less than 15,000, this mixture did not pass the HWT stripping criteria and is rutting susceptible.

## 8. Report the results

Include the following in the final report:

- Contract ID, Project Number, Mix Identification
- Confirm HWT Equipment meets AASHTO T 324
- Confirm Test temperature = 50 ° C
- Confirm Number of cycles completed = 20,000 Passes
- Report Total Average Rut Depth at 20,000 Passes
- Establish Rut depth curves
- Provide equations for Creep Slope Best Fit Line and Stripping Slope Best Fit Line using Linear regression methods in excel or other programs.
- Report the Slope Ratio
- Report the Stripping Inflection Point
- Report the parameters that the asphalt mixture meets using the table below. When one parameter passes, the other parameters may be omitted.

Parameter	Stripping Criteria	Pass or Fail?
Total Rut Depth	Less Than or Equal to 4 mm	
Slope Ratio (SR)	Less Than 2.0	
Stripping Inflection Point (SIP)	Greater Than 15,000 Passes	



## SECTION 501

### CONCRETE

#### UNCHANGED SPECS – INTENTIONALLY NOT SHOWN

**501.4 Sampling.** Sampling of fresh concrete shall be in accordance with AASHTO R 60, except that for central or truck mixed concrete, the entire sample for slump and air tests and for molding compressive strength specimens may be taken at one time after approximately one cubic yard of concrete has been discharged, instead of at three or more regular intervals during the discharge of the entire batch. Acceptability of the concrete for slump and air content and, if applicable, for strength requirements, will be determined by tests on these samples.

**501.4.1 Curing.** Concrete cylinders molded in the field shall be cured in accordance with AASHTO R 100.

**501.4.1.1 Standard Curing.** Concrete cylinders made for assessing the concrete mix design shall be standard cured. Compressive strength testing shall be performed at 28-days in accordance with AASHTO T 22.

**501.4.1.2 Field Curing.** Concrete cylinders made for assessing construction activities shall be field cured. Compressive strength testing shall be performed in accordance with AASHTO T 22. Construction activities being assessed may involve, but not limited to, the following items:

- (a) Opening to traffic
- (b) Evaluating bridge deck wet curing
- (c) Form removal
- (d) Discontinuance of cold weather protection

#### UNCHANGED SPECS – INTENTIONALLY NOT SHOWN



## SECTION 610

### PAVEMENT SMOOTHNESS

UNCHANGED SPECS – INTENTIONALLY NOT SHOWN

**610.5.3 Marred Surface Deductions.** A minimum deduction of 20 percent of the contract unit price of the paving quantities will be made for marred surface areas as defined in [Sec 610.4.87](#). The deduction will be applied to an area of pavement extending from edge of the pavement to a longitudinal joint or between longitudinal joints in that section of pavement affected. If the length of the section affected is less than ~~10-15~~ feet, the deduction will be computed for ~~10-15~~ feet. For asphalt pavement and overlays, the deduct shall apply to the surface course and all sub-courses placed within the bounds of the marred surface area.

UNCHANGED SPECS – INTENTIONALLY NOT SHOWN



## SECTION 1015

### BITUMINOUS MATERIAL

#### UNCHANGED SPECS – INTENTIONALLY NOT SHOWN

**1015.3 Sampling, Testing and Acceptance Procedures.** The supplier shall certify that the bituminous material complies with the specification requirements.

**1015.3.1 Certification.** The supplier shall furnish the truck driver a copy of the bill of lading, manifest or truck ticket to be available to MoDOT at the destination prior to unloading. The engineer at the source shall be furnished a copy. The bill of lading, manifest or truck ticket shall provide the following information regarding the shipment: type and grade of material, chemical additives, such as polyphosphoric acid (PPA), used in modification [or for cross-linking](#), specific gravity at 60 F, net gallons, consignee, truck number, identification number, weight of truck before and after loading, destination, date loaded, name and location of the source, and a certification statement. The certification statement shall be signed by an authorized representative of the supplier and shall be substantially as follows:

"This certifies that the bituminous material in this shipment is in accordance with MoDOT specifications for the grade specified and the weights (masses) shown hereon were obtained on MoDOT approved scales and are correct within the specified scale requirements."

#### UNCHANGED SPECS – INTENTIONALLY NOT SHOWN

**1015.3.7 Railroad Shipments.** For railroad shipments from refineries where inspection is not maintained by MoDOT, the supplier shall sample each car load at the source and submit the sample promptly to the Central Laboratory. A bill of lading or identification sheet shall accompany each sample and contain the following information: car number, type and grade of material, chemical additives, such as PPA, used in modification [or for cross-linking](#), quantity represented, including gross gallons, temperature and net gallons at 60 F, destination of shipment, project number and consignee. A certification statement as specified in [Sec 1015.3.1](#) shall accompany each sample. Approval of the source may be withdrawn if samples submitted are not representative of the material shipped in the car.

#### UNCHANGED SPECS – INTENTIONALLY NOT SHOWN

### SECTION 1015.10 PERFORMANCE GRADED ASPHALT BINDER.

**1015.10.1 General.** Performance graded asphalt binder shall be an asphalt-based binder produced from petroleum residue either with or without the addition of non-particulate organic modifiers, except Re-refined Engine Oil Bottoms (REOB) and Vacuum Tower Asphalt Extenders (VTAE) shall not be used as modifiers. [Polyphosphoric Acid \(PPA\) may be used at a maximum dosage of 0.25 percent by weight of binder to promote polymer cross-linking and interaction. Higher PPA dosages or other types of modifiers used for cross-linking shall be approved by the engineer.](#) The [asphalt binder](#) grade shall be as specified in the contract.

#### UNCHANGED SPECS – INTENTIONALLY NOT SHOWN



## SECTION 1049

### PRECAST CONCRETE BOX CULVERTS

#### UNCHANGED SPECS – INTENTIONALLY NOT SHOWN

**1049.4 Design.** Except as otherwise specified herein, precast concrete box sections for the culvert shall be in accordance with ASTM C 1577. Designs shall be submitted to the inspecting District.

**1049.4.1** Substituted precast concrete box culvert sections shall be designed for the earth cover shown on the plans for the cast-in-place box culvert, and shall be equal in height and cross-sectional area or as approved by the engineer.

**1049.4.2 Special Designs.** The producer shall request approval of any modified and special designs which differ from the designs in ASTM C 1577. The request for such modified and special designs shall fully describe any deviations from those standards, including a drawing showing wall thickness, concrete design strength, the type, size and placement of reinforcement, and inside or outside dimensions of both of the box sections. [Precast split-box designs in accordance with ASTM C1786 with or without modification are not acceptable.](#)

**1049.4.3** The minimum barrel length for box or end section shall be 2 feet.

**1049.4.4** End sections may be precast or cast-in-place. If precast, the barrel, floor and wing walls shall be cast as an integral unit. In either case, the end sections shall be constructed to the same dimensions, shapes, and with the same reinforcement as shown on the plans for cast-in-place culvert.

**1049.4.5** Segmented end sections may be provided, but will be considered a modified design and will require approval as such.

**1049.4.6** Toe walls shall be provided on both the upstream and downstream ends as shown on the plans, and may be cast-in-place or precast. Precast toe walls shall be connected to the end section floor.

#### UNCHANGED SPECS – INTENTIONALLY NOT SHOWN

### 751.8.1.5 Precast Culvert

#### General

All MoDOT cast-in-place (CIP) concrete box culverts are allowed to be constructed using alternate precast concrete box culvert sections in accordance with [Sec 733](#), unless specified otherwise. [Requirements for submitting special or modified designs are described in Sec 1049. Precast split-box designs in accordance with ASTM C1786 with or without modification are not an acceptable precast alternative.](#) The converse is not true and precast concrete box culverts may be specified only. Pay items and quantities shall remain unchanged from those typically used for CIP concrete box culverts. When a box culvert is required to be constructed using precast concrete box culvert sections because of an accelerated timeline for construction, pay item and quantity of the precast box culvert shall be based on the length of the precast culvert to the nearest foot measured along the geometrical center of the culvert floor.

#### Pedestrian Box

Where a precast concrete box culvert could be used as a pedestrian (or “people”) box for walk-through or bicycle path, having multiple joints typically spaced at not greater than 6 ft. may be unacceptable due to tripping hazards, ponding/freezing (settlement of many smaller length sections) or uncomfortable riding surface. Consideration should also be given to special waterproofing or non-corrosive water stops for watertight construction joints.

#### Multi-Cells

In multi-cell precast construction the staggered placement of units should be avoided. Staggering units results in an irregular end section that loses continuity over the interior wall(s).

#### Culvert Ties

Precast box culvert ties in accordance with Sec 733 and [Std. Plan 733.00](#) shall be required for the same reasons as concrete collars are required for CIP concrete box culverts. Typically the regular strength connections details should be used. The extra strength connection details shall be used for special cases requiring higher strengths or greater durability, for example when connecting energy dissipating baffles rings or when under low fills and a roadway. If a precast box culvert is required because of an accelerated timeline and collar beams would otherwise be required then culvert ties shall be specified with the cost of ties being considered completely covered by the contract unit price for the precast box culvert.

## 1049.2 Procedure

Inspection and reporting of coarse aggregate, fine aggregate, cement, fly ash shall be as appropriate for those materials.

Prior to concrete being poured, confirm the amount and placement of reinforcement. The amount and placement of welded wire fabric is to be as specified in ASTM C 1577 as applicable.

Compressive tests may be made on either concrete cylinders or cores drilled from the wall of the sections at the option of the manufacturer. If the manufacturer chooses to take cylinders and they fail, the manufacturer then has the option to core sections for possible acceptance.

Cylinders must be made in accordance with AASHTO T 280 and must be capped.

Acceptance cylinders are the responsibility of the manufacturer. An inspector's job is to review the results for adequacy. It is good procedure to randomly validate the manufacturer results by making cylinders for comparison.

Cores in accordance with AASHTO T 280 must be both capped and lime cured.

The finished sections are to be examined for conformance to dimensions, workmanship and marking. All permissible variations are specified in ASTM C 1577.

Each section shall be marked as follows by the manufacturer by indenting into the concrete or with waterproof paint:

(a) Box section span, rise, table number, design earth cover and specification designation.

(b) Date of manufacture.

(c) Name or trademark of the manufacturer.

(d) Each section shall be clearly marked by indentation on either the inner or outer surface during the process of manufacturer so that the location of the top will be evident immediately after the forms are stripped. In addition, the word "top" shall be lettered with waterproof paint on the inside top surface.

(e) If the manufacturer is allowed to produce under an approved QC program, each section considered by the manufacturer to be specification compliant will be marked by the manufacturer with the indicator required by the QC program. Sections rejected by the manufacturer may be marked or handled in accordance with the QC program but the rejection must be clearly indicated.

(f) If the manufacturer is allowed to produce under an approved QC program, each section to be shipped will be marked by the manufacturer with the Sample ID number provided by the district. If the producer has marked a piece with a Sample ID number, and the section is found to be unacceptable during an audit, the Sample ID number must be neatly obliterated.

Sections accepted by MoDOT inspection are to be marked with "OK-MoDOT" by the inspector. Rejected sections are to be marked with a single vertical mark, near the manufacturers marking and shall be made with weather resistant marking material.

Any modification of a unit, other than constructing a box unit exactly as described in the specifications, is considered a special design, including any pipe cutouts or drainage holes to be made in the unit for any reason, whether prior to, during, or after final placement on site. ~~Modified and special split-box designs in accordance with ASTM C1786 are not acceptable.~~ Any special or modified designs submitted for approval must have been reviewed and sealed by a professional engineer, registered in Missouri, and representing the contractor or producer. Requirements for submitting special or modified designs are described in [Sec 1049](#). ~~Precast split-box designs in accordance with ASTM C1786 with or without modification are not an acceptable precast alternative.~~ Approval of a special design for one job does not constitute approval for any other job.

Submittal of special designs is discussed further in [EPG 106.16 Special Designs](#). Special and modified design units, at the discretion of the district, may not be accepted under a QC program.

If reinforcing bars are proposed in lieu of the welded wire fabric listed in AASHTO, it is considered to be a special design.

If end sections are proposed to be constructed other than by the MoDOT Standard Plans for cast-in-place culverts, it is considered to be a special design. Calculations and other proof of equal or better design must be submitted with the request.

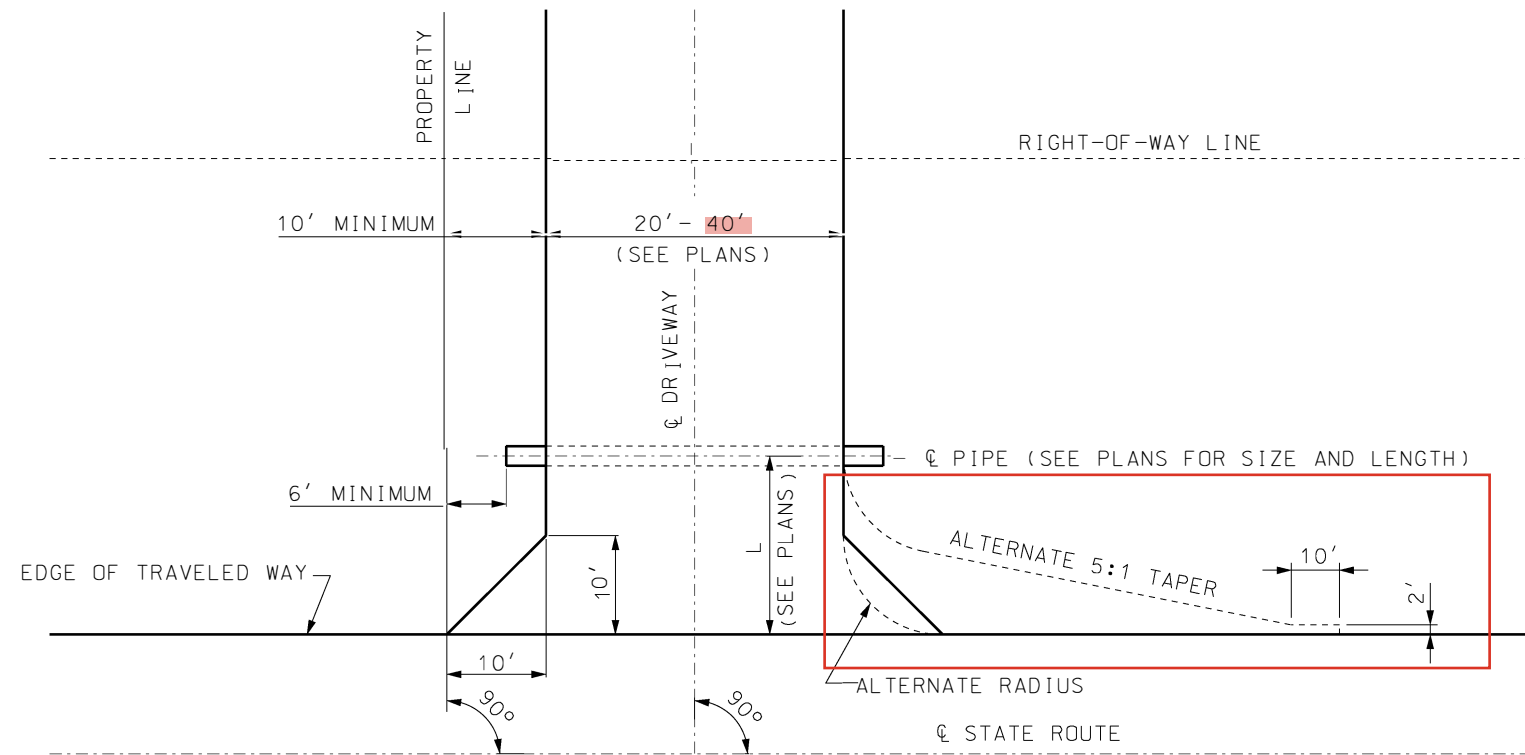

DRIVEWAY SIDE SLOPES: \*

1 TO 1700 VEHICLES PER DAY ON STATE ROUTE USE 3:1 SLOPE (OR 6:1 SLOPE WHERE PRACTICABLE).

OVER 1700 VEHICLES PER DAY ON STATE ROUTE USE 6:1 SLOPE (OR FLATTER WHERE PRACTICABLE).

\* IN ORDER TO MINIMIZE THE USE OF 6:1 SLOPED END PIPE SECTIONS ON NEW CONSTRUCTION AND WHERE POSSIBLE ON EXISTING ROUTES, THE LOCATION OF DRAINAGE PIPE SHOULD BE BEYOND THE CLEAR ZONE DISTANCE AS SHOWN IN TABLE 3.1 OF THE 1988 EDITION OF "ROADSIDE DESIGN GUIDE".

GENERAL NOTES:

RECOMMENDED DRIVEWAY WIDTH  
RESIDENTIAL - 20'  
AGRICULTURAL - 30'

NO PART OF THE DRIVEWAY EXCLUDING TAPERS SHALL BE CONSTRUCTED BEYOND THE PROPERTY FRONTAGE.

SURFACING SHALL BE AS SHOWN ON THE PLANS OR PERMIT.

4 INCHES OF TYPE 1 OR 5 BASE SHALL BE PLACED AND COMPACTED BENEATH THE AREAL SURFACE OF CONCRETE AND ASPHALT DRIVEWAYS.

LENGTH OF PIPE SHALL BE DETERMINED BY DEPTH AND LOCATION OF DITCH. (MINIMUM 32' LENGTH OF MINIMUM 15" DIAMETER PIPE), SEE PLANS.

THIS DRAWING ILLUSTRATES DRIVEWAY DETAILS FOR MINIMUM SITUATIONS. TRAFFIC VOLUMES, SAFETY CONSIDERATIONS, LOCAL REQUIREMENTS, ETC., MAY DICTATE MORE EXTENSIVE IMPROVEMENTS THAN ILLUSTRATED.

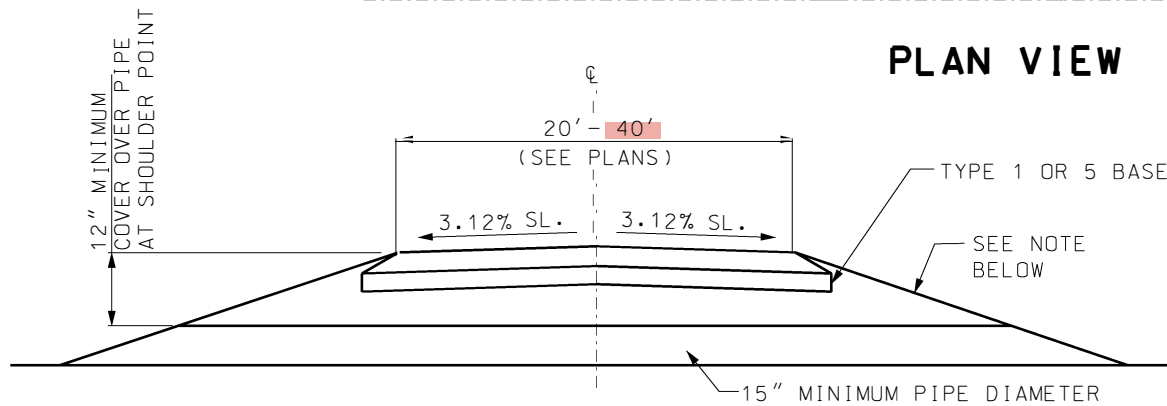

DRIVEWAY TYPICAL SECTION

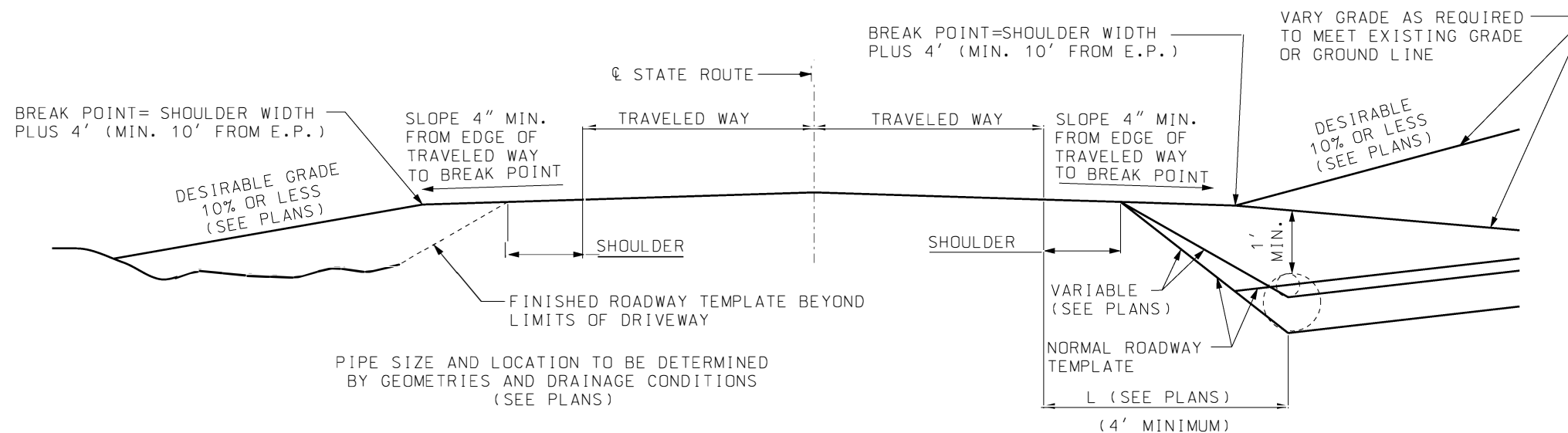

IN FILLS

PROFILE VIEW

IN CUTS

**MoDOT** MISSOURI HIGHWAYS AND TRANSPORTATION COMMISSION  
105 WEST CAPITOL  
JEFFERSON CITY, MO 65102  
1-888-ASK-MODOT (1-888-275-6636)

**DRIVEWAY**  
TYPE I

DATE EFFECTIVE: 07/01/2020  
DATE PREPARED: 7/25/2025

**203.61B**

SHEET NO.  
1 OF 1

EPG 940.16.4 (Replacing Table 940.16.4 only)

Driveway Traffic Category	Average Daily Traffic Using Driveway	Peak Hour Traffic Using Driveway	Width at Right of Way Line With Two-Way Access <sup>6</sup>	Width at Right of Way Line With One-Way Access <sup>6</sup>	Right-Turn Radius for Driveways in Urban Areas (At or below 45 mph Posted Speed)	Right-Turn Radius for Driveways in Rural Areas (Greater than 45 mph Posted Speed)
Residential	0 – 100	0 – 10	20 ft. <sup>1</sup> – 30 ft. <sup>2</sup>	NA	10 ft.	25 ft.
Agricultural <sup>7</sup>	0-100	0-10	30 ft. <sup>1</sup> – 40 ft. <sup>2</sup>	N/A	20 - 30 ft. <sup>5</sup>	30- 40 ft. <sup>5</sup>
Low Volume Commercial/Industrial	< 1500	< 150	28 ft. <sup>2</sup> – 42 ft. <sup>3</sup>	20 ft. <sup>1</sup>	25 ft.	50 ft.
Medium Volume Commercial/Industrial	1,500 – 4,000	150 – 400	42 ft. <sup>3</sup> - 54 ft. <sup>4</sup>	20 ft. <sup>1</sup> - 30 ft. <sup>2</sup>	Design to handle typical large truck that uses the driveway	Design to handle typical large truck that uses the driveway
High Volume Commercial/Industrial	> 4000	> 400	Determined through a traffic study - normally 42 ft. or greater	Generally not applicable	Design to handle typical large truck that uses the driveway	Design to handle typical large truck that uses the driveway
<sup>1</sup> One-lane driveways.						
<sup>2</sup> Driveway striped for two lanes.						
<sup>3</sup> Driveway striped for three lanes.						
<sup>4</sup> Driveway striped for four lanes.						
<sup>5</sup> Uncurbed radius or taper						
<sup>6</sup> Larger widths up to 60ft may be allowable when right of way is to narrow to accommodate turning radius or based on engineering judgment.						
<sup>7</sup> Larger widths up to 60ft may be allowable dependant on the type of agricultural activities and equipment the driveway would be expected to accommodate based on engineering judgement.						

**Table 940.16.4**

Driveway Traffic Category	Average Daily Traffic Using Driveway	Peak Hour Traffic Using Driveway	With Two-Way Access	With One-Way Access
Residential	0 – 100	0 – 10	20* ft. – 30** ft.	NA
Low Volume Commercial/Industrial	< 1500	< 150	28 ft.** - 42 ft.***	20 ft.*
Medium Volume Commercial/Industrial	1,500 – 4,000	150 – 400	42 ft.*** - 54 ft.****	20 ft.* - 30 ft.**
High Volume Commercial/Industrial	> 4000	> 400	Determined through a traffic study - normally 42 ft. or greater	Generally not applicable
* One-lane driveways.				
** Driveway striped for two lanes.				
*** Driveway striped for three lanes.				
**** Driveway striped for four lanes.				

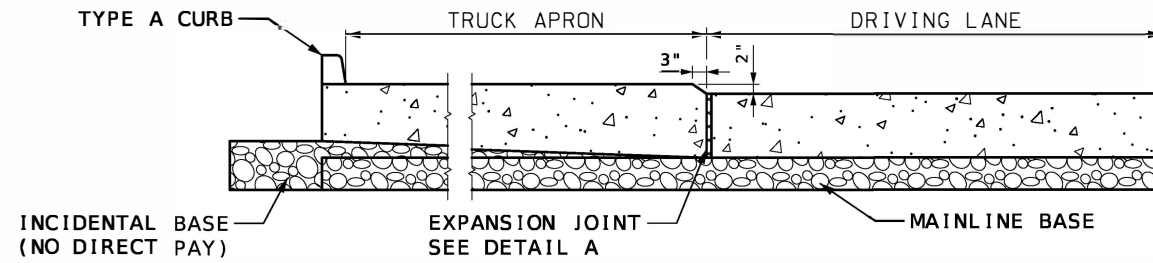

**TRUCK APRON BEVELED EDGE WITH EXPANSION JOINT**

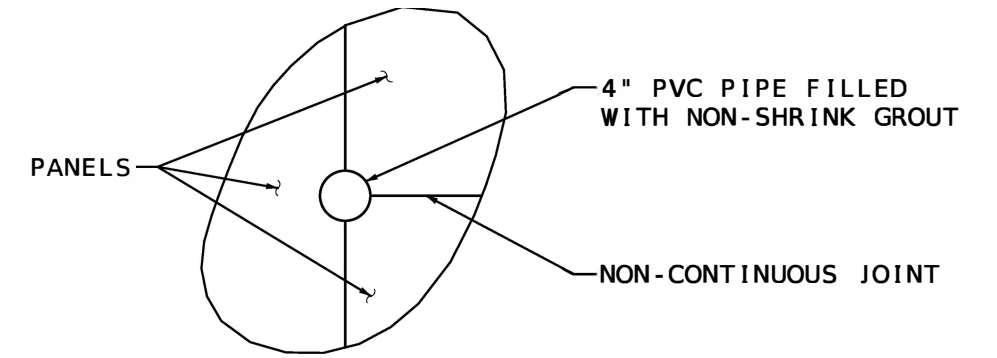

**JOINT TERMINATION CORE**

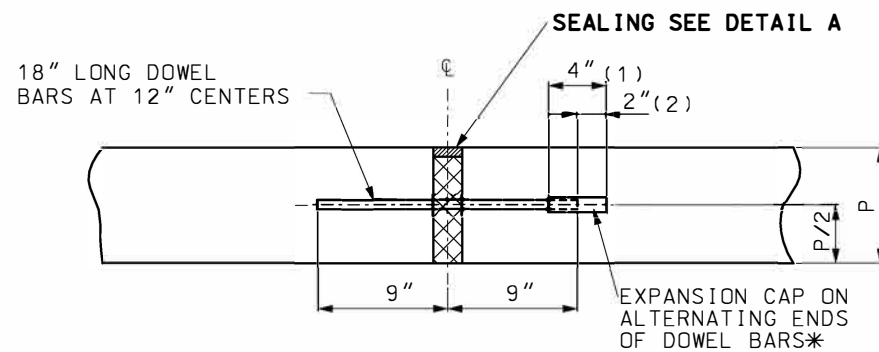

**EXPANSION JOINT (ER)**

- (1) LENGTH OF CAP
- (2) GAP BETWEEN END OF CAP AND DOWEL.

\* FOR EXPANSION JOINTS FORMED USING A CONSTRUCTION HEADER, THE EXPANSION CAPS SHALL BE INSTALLED ON THE EXPOSED END OF EACH BAR ONCE THE HEADER HAS BEEN REMOVED AND THE JOINT FILLER MATERIAL HAS BEEN INSTALLED.

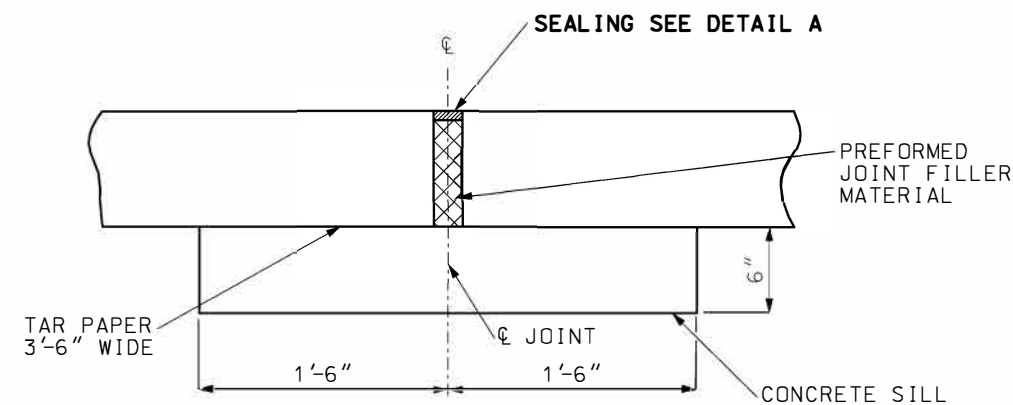

SILL SHALL EXTEND 18" BEYOND EACH EDGE OF THE PAVEMENT AND SHALL BE CONSTRUCTED OF CONCRETE REGARDLESS OF ADJACENT BASE MATERIAL.

**ALTERNATE EXPANSION JOINT (ER)**  
(CONTRACTOR MAY SELECT EITHER EXPANSION JOINT (ER))

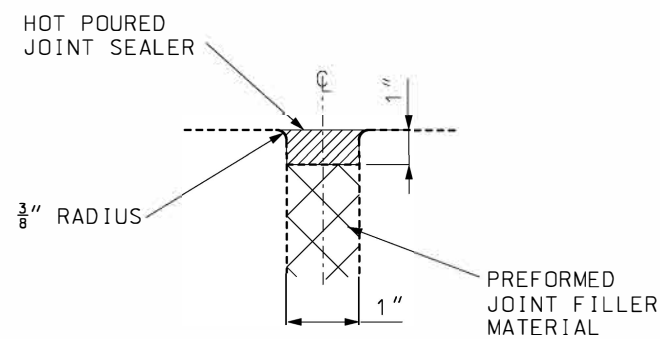

**DETAIL A**

**GENERAL NOTES:**

- JOINT LAYOUT IS TO BE APPROVED BY THE ENGINEER AND SHOULD AVOID THE FOLLOWING:
- SLABS LESS THAN 2 FEET WIDE
  - SLABS GREATER THAN 15 FEET WIDE
  - ANGLES LESS THAN 60 DEGREES
  - INTERIOR CORNERS AND ODD SHAPES

SEE STANDARD PLAN 502.05 FOR OTHER JOINT DETAILS.

**MoDOT** MISSOURI HIGHWAYS AND TRANSPORTATION COMMISSION  
 105 WEST CAPITOL JEFFERSON CITY, MO 65102  
 1-888-ASK-MODOT (1-888-275-6636)

**CONCRETE ROUNDABOUT JOINT LAYOUT**

DATE EFFECTIVE: 10/1/2026	<b>502.06</b>	SHEET NO. 1 OF 2
DATE PREPARED: 3/3/2026		

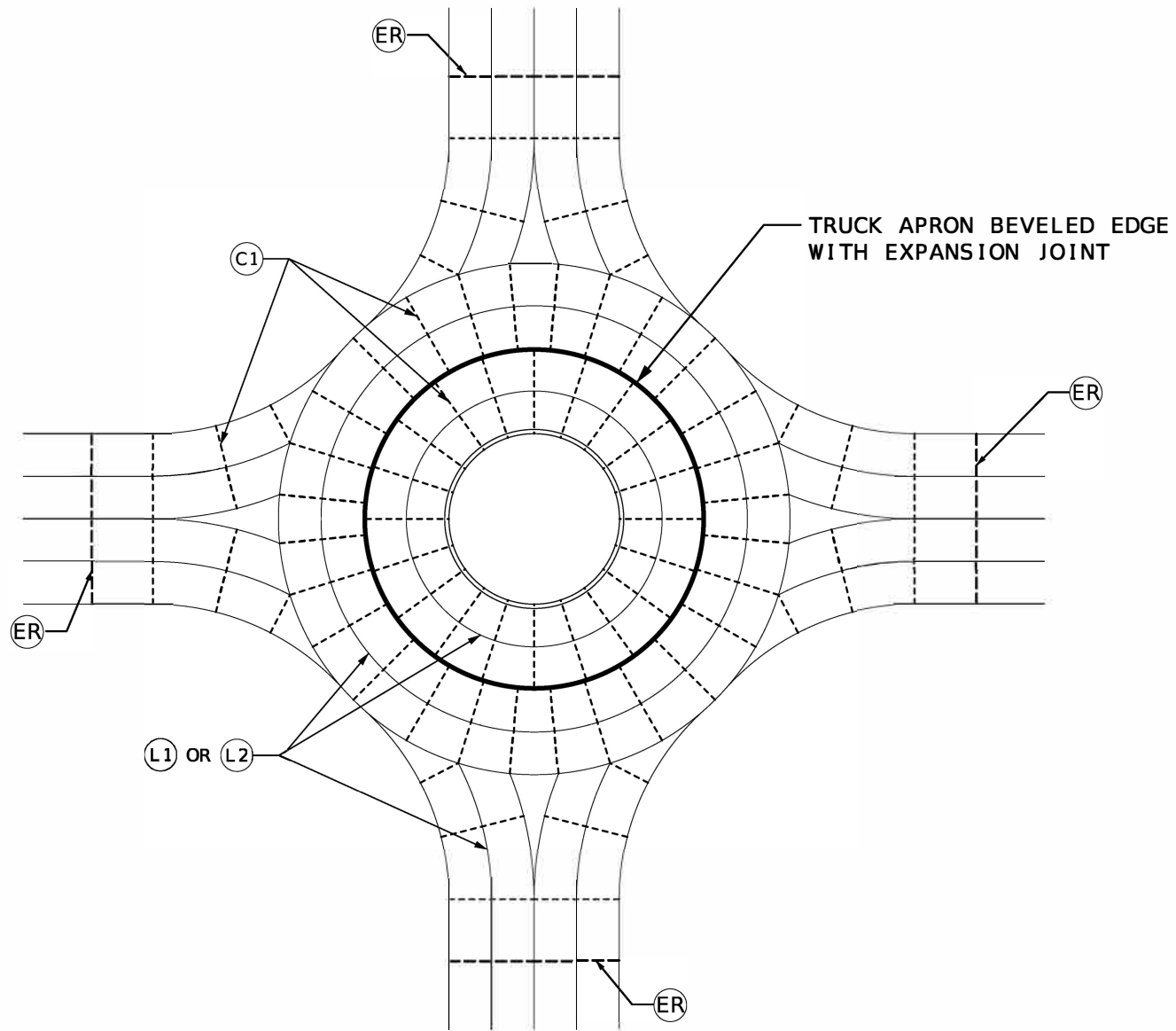

ISOLATED CIRCLE METHOD

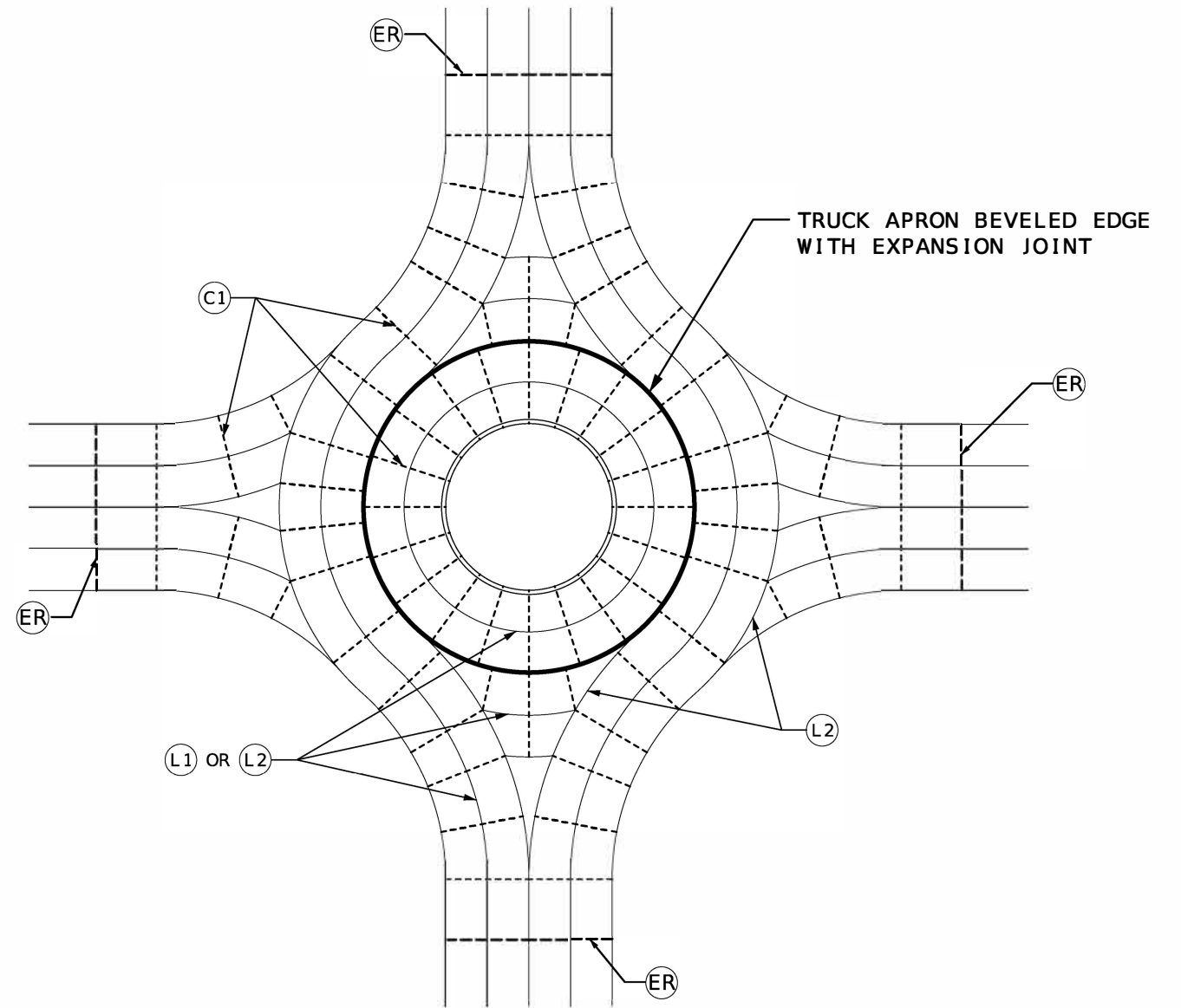

PAVE-THROUGH METHOD

	<b>MISSOURI HIGHWAYS AND TRANSPORTATION COMMISSION</b> 105 WEST CAPITOL JEFFERSON CITY, MO 65102 1-888-ASK-MODOT (1-888-275-6636)	
	<b>CONCRETE ROUNDABOUT JOINT LAYOUT</b>	
DATE EFFECTIVE: 10/1/2026 DATE PREPARED: 3/3/2026	<b>502.06</b>	SHEET NO. 2 OF 2

### 106.3.2.93 TM-93, Alkali Carbonate Reactivity Screening

This test method establishes the procedures for identifying potential alkali carbonate reactivity (expansion) and acceptance of aggregate used in concrete pavements and masonry. This test method applies to new quarries, new ledges (and combinations of ledges), existing quarries and ledges.

#### 106.3.2.93.1 Means of Evaluating Aggregate Alkali Carbonate Reactivity

##### 1. Chemical Analysis

The chemical analysis of aggregate reactivity is an objective, quantifiable and repeatable test. MoDOT will perform the chemical analysis per the process identified in ASTM C 25 for determining the aggregate composition. The analysis determines the calcium oxide (CaO), magnesium oxide (MgO), and aluminum oxide ( $\text{Al}_2\text{O}_3$ ) content of the aggregate. The chemical compositions are then plotted on a chart with the CaO/MgO ratio on the y-axis and  $\text{Al}_2\text{O}_3$  percentage on the x-axis per Fig. 2 in AASHTO R 80. Aggregates are considered potentially reactive if the  $\text{Al}_2\text{O}_3$  content is greater than or equal to 1.0% and the CaO/MgO ratio is either greater than or equal to 3.0 or less than or equal to 10.0 (see chart below). See flow charts in 106.3.2.93.2 for approval [processhierarchy](#).

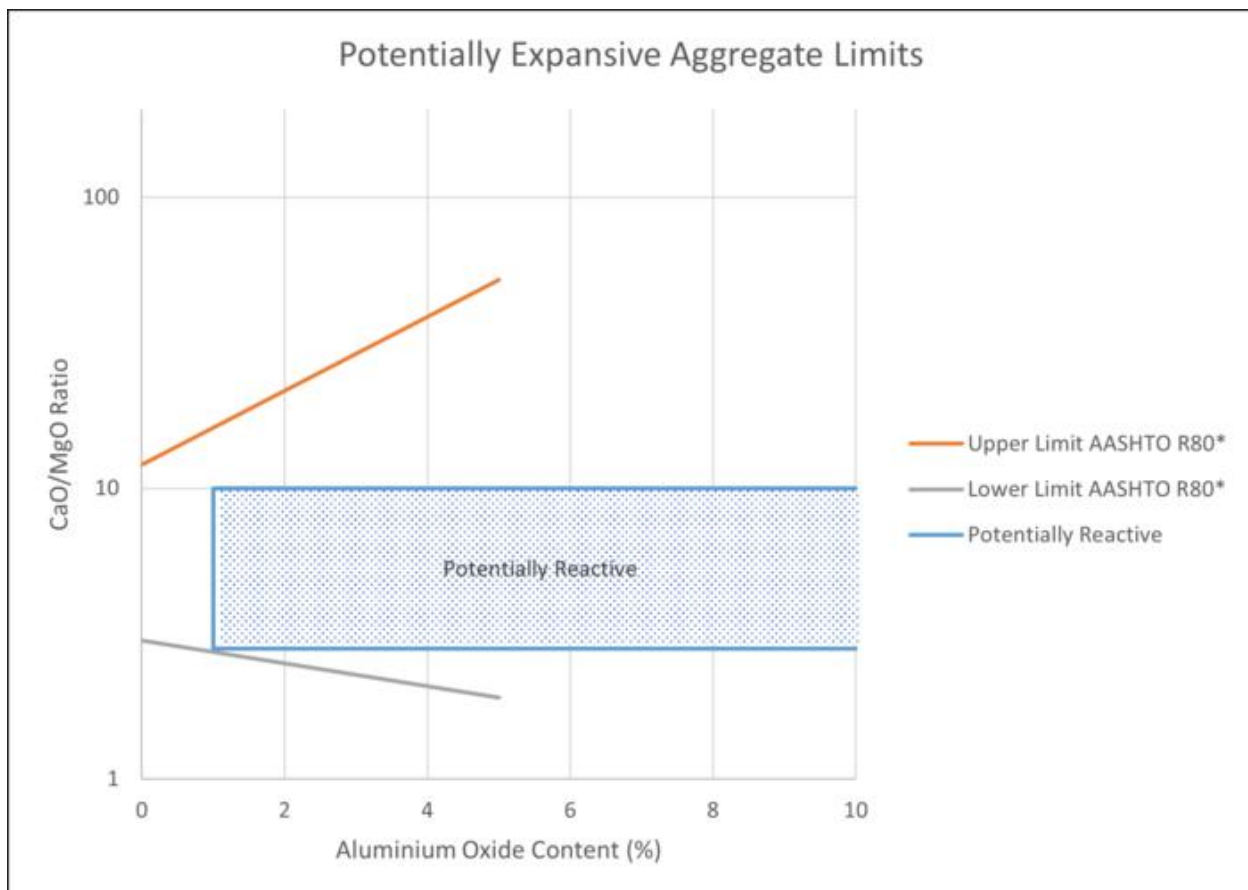

\* MoDOT's upper and lower limits of potentially reactive (shaded area) aggregates.

## 2. Petrographic Examination

A petrographic examination is another means of determining alkali carbonate reactivity. The sample aggregate for petrographic analysis will be obtained at the same time as the source sample. MoDOT personnel shall be present at the time of sample. The petrographic sample shall be placed in an approved tamper-evident container (provided by the quarry) for shipment to petrographer. Per ASTM C 295, a petrographic examination is to be performed by a petrographer with at least 5 years of experience in petrographic examinations of concrete aggregate including, but not limited to, identification of minerals in aggregate, classification of rock types, and categorizing physical and chemical properties of rocks and minerals. The petrographer will have completed college level course work in mineralogy, petrography, or optical mineralogy. MoDOT does not accept on-the-job training by a non-degreed petrographer as qualified to perform petrographic examinations. MoDOT may request petrographer's qualifications in addition to the petrographic report. The procedures in C 295 shall be used to perform the petrographic examination. The petrographic examination report to MoDOT shall include at a minimum:

- Quarry name and ledge name; all ledges ~~if~~ used ~~if~~ in combination
- MoDOT District ~~where~~ quarry resides
- Date sample was obtained; date petrographic analysis was completed
- Name of petrographer and company/organization affiliated
- Lithographic descriptions with photographs of the sample(s) examined
- Microphotographs of aggregate indicating carbonate particles and/or other reactive materials
- Results of the examination
- All conclusions related to the examination

See flow charts in EPG 106.3.2.93.2 for the approval ~~process~~ hierarchy. See EPG 106.3.2.93.3 for petrographic examination submittals. No direct payment will be made by the Commission for shipping the petrographic analysis sample to petrographer, or for the petrographic analysis performed by the petrographer.

## 3. Concrete Prism/Beam Test

ASTM C 1105 is yet another means for determining the potential expansion of alkali carbonate reactivity in concrete aggregate. MoDOT will perform this test per C 1105 at its

Central Laboratory. Concrete specimen expansion will be measured at 3, 6, 9, and 12 months. The test specimens will be considered alkali carbonate reactive (expansive) if the specimens expand greater than ~~0.015% at 3 months, 0.025% at 6 months, or~~ 0.030% at 12 months. See flow chart in EPG 106.3.2.93.2 for the approval ~~hierarchy process~~.

### 106.3.2.93.2 Approval Process for Potential Alkali Carbonate Reactive Aggregate

**1. Process for New Ledges and New Quarries** The flowchart shown in Figure 1 shows the process for determining alkali carbonate reactivity (expansiveness) in new ledges and quarries. It is important to note TM-93 is only for determining whether or not aggregate is potentially expansive. All other requirements of Sec. 1005 shall be met for the ledge(s) to be approved for use in pavement or masonry concrete.

Should ASTM C 1105 test method need to be performed on the aggregate, the quarry will be notified by District personnel that this test method requires 12 months to complete, and approval of aggregate during those 12 months will be provisionally granted based on physical test results. Final approval will be determined upon completion of ASTM C 1105. Aggregate that fails to meet the expansion limit of 0.030%, the aggregate cannot be approved for use in pavement or masonry concrete. The aggregate however, can be considered for other uses based on meeting required specifications.

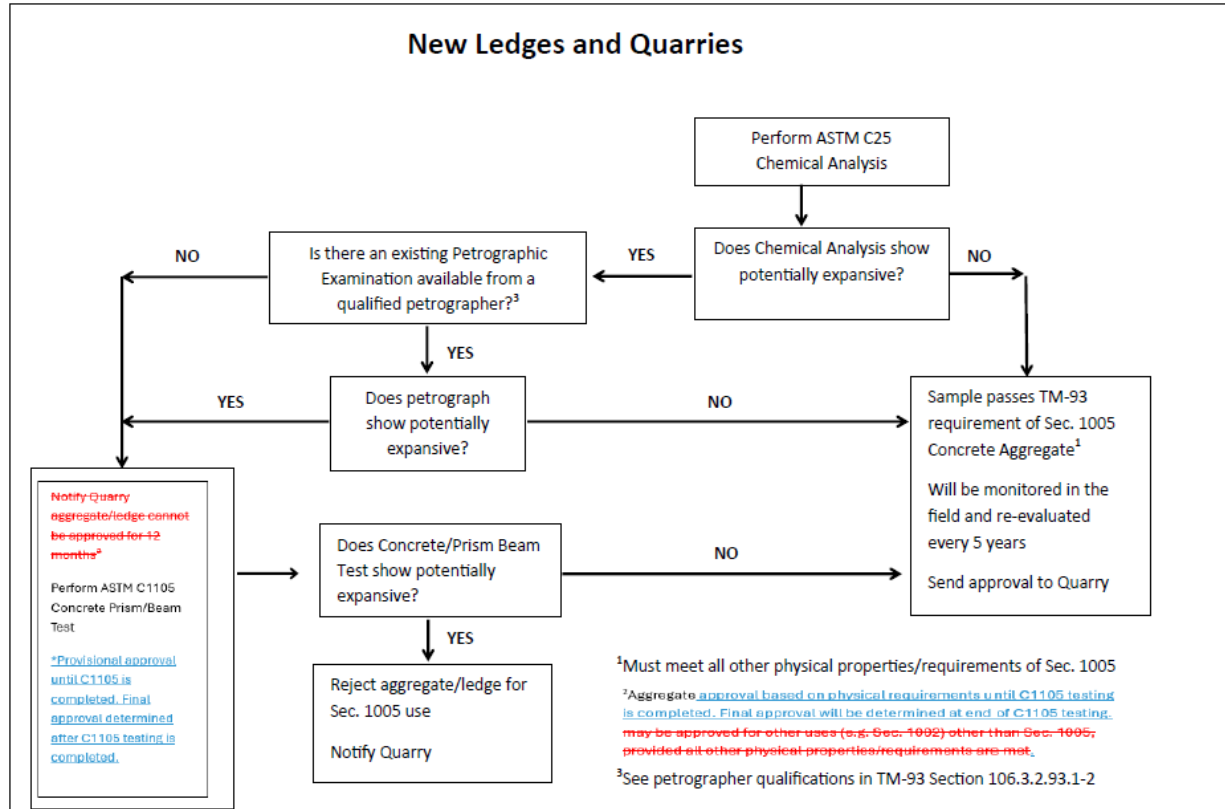

Figure 1. Process for determining alkali carbonate reactivity for new ledges and quarries.

## 2. Process for Existing Ledges and Existing Quarries

The flowchart shown in Figure 2 shows the process for determining alkali carbonate reactivity (expansiveness) in existing ledges and quarries. It is important to note TM-93 is only for determining whether or not aggregate is potentially expansive. All other requirements of Sec. 1005 shall be met before the ledge(s) are approved for use in pavement or masonry concrete.

Should ASTM C 1105 test method need to be performed on the aggregate, the quarry will be notified by District personnel that this test method requires 12 months to complete, and approval of aggregate during those 12 months; will be provisionally granted based on physical test results. Final approval will be determined upon completion of ASTM C 1105. Aggregate that fails to meet the expansion limit of 0.030% ~~the aggregate~~ cannot be approved for use in pavement or masonry concrete. The aggregate however, can be considered for other uses based on meeting required specifications.



All petrographic reports will be digitally stored by Central Office Construction and Materials Division.

## 109.12 Change Orders

---

The primary purpose of a change order is to document a supplemental change to the contract. The official definition, as stated in [Sec 101](#), is as follows:

**Change Order** - *A written order from the engineer to the contractor, as authorized by the contract, directing changes in the work as made necessary or desirable by unforeseen conditions or events discovered or occurring during the progress of the work.*

The second most primary purpose of the change order process is to ensure proper authority has been granted before proceeding with revisions in quantities or changes in scope of work, design concept, time or specifications. Changes in scope should be limited to the original intent, purpose and limits (length and width) of the job. In instances where proposed changes in scope go beyond these original job parameters, the change order shall be considered a major change order (Sequence 4). Significant scope changes require the State Construction and Materials Engineer to discuss the requested changes with the Asst. Chief Engineer prior to granting approval.

Change orders must have approval at all required levels before the work proceeds. Exceptions are granted for routine or minor changes, or emergency revisions for which verbal approval has been granted. In rare cases it may be necessary to proceed with emergency measures without prior approval. In such cases, verbal approval should be sought as soon as practicable. Indicate in the DWR remarks the name of the individual who provided verbal approval. For change orders that provide payment for additional work, all attempts should be made to complete the process promptly so that the contractor can be compensated at the end of the pay period in which the work was performed.

**Design Changes.** When the change order is a result of a design change, all appropriate design criteria should be reviewed in coordination with the Transportation Project Manager. If the design criteria cannot be met, a Design Exception is required. See EPG 131.1.4.

**Environmental Change Orders** - Any design changes that include disturbance of new areas on the project, or that include any other unplanned environmental impacts, should be reviewed by the Project Manager to determine if a request for environmental services is necessary prior to implementation.

**Job Order Contract Change Orders.** Job Order Contracts have unique contract terms that limit spending to a budgeted amount and often include pre-approved time extensions. Reference [EPG 147.3.9 Change Order Approvals](#) for additional guidance on administration of change orders for Job Order Contracts.

# 131.1 Design Exception Process

[Jump to navigation](#)[Jump to search](#)

## Contents

- [131.1.1 When to Complete a Design Exception](#)
- [131.1.2 The 10 Controlling Criteria](#)
- [131.1.3 Approval Requirements](#)
  - [131.1.3.1 Projects of Divisional Interest \(PODI\)](#)
- [131.1.4 The Design Exception Process](#)
  - [131.1.4.1 The Development, Concurrence and Approval Process](#)
    - [131.1.4.1.1 Roadway Design Exceptions](#)
    - [131.1.4.1.2 Bridge Design Exceptions](#)
    - [131.1.4.1.3 Both Roadway and Bridge Item Related Design Exceptions](#)
  - [131.1.4.2 Issue Resolution](#)
  - ~~[131.1.4.3 Design Exception Numbering and Logging](#)~~
- [131.1.5 Required Information](#)
- [131.1.6 Revising an Approved Design Exception](#)
- [131.1.7 Deficient Vertical Clearances on Interstates](#)

## Forms

[Design Exception Information Form](#)

[Vertical Clearance Design Exception Coordination with SDDCTEA](#)

## 131.1.1 When to Complete a Design Exception

A design exception documents design elements of an improvement that vary from [general guidance on](#) engineering policy. In most cases, the need for an exception results from an inability to reasonably meet the design criteria. [The determination to approve a project design that does not conform to the minimum criteria is to be made only after due consideration is given to all project conditions such as maximum service and safety benefits for the dollar invested, compatibility with adjacent sections of roadway and the probable time before reconstruction of the section due to increased traffic demands or changed conditions.](#)

An approved exception [simply](#) documents the engineering-based determination that variance from MoDOT's [published](#) engineering policy is necessary and appropriate. It is the primary tool to detail not only the decision itself, but also what was considered when the decision was made.

When there is doubt whether a design exception is required, the Assistant State Design Engineers, Assistant State Bridge Engineer, [Structural Liaison Engineer \(SLE\)](#), or the Design Liaison Engineer (DLE) for the district should be consulted.

A design exception is encouraged whenever it is feasibly or technically impossible to reasonably meet the [preferred minimum](#) design criteria or wherever there is potential for additional value outside of written engineering policy. Design exceptions should not be

considered breaches of policy as much as opportunities to add practicality or value to the design.

An approved exception is not a request for permission; rather, it simply documents deliberate variances from general engineering policy.

The Federal Highway Administration (FHWA) Design Decision Documentation and Mitigation Strategies for Design Exceptions may be used in the development of the design exception.

## 131.1.2 The 10 Controlling Criteria

There are 10 controlling criteria that the FHWA has identified as the most important or critical elements for the design of projects on the National Highway System (NHS). ~~Projects designated for federal involvement on design exceptions in the PODI matrix, located on an NHS Route, require a MoDOT and FHWA approved written design exception if a controlling criteria, as established in MoDOT's EPG, is not met for any of the 10 elements listed in Table 131.1.2. FHWA only approves design exceptions for the controlling criteria listed in Table 131.1.2 when it has determined that a project is a Project of Division Interest (PODI) with Design Exception selected.~~

The controlling criteria, which vary based upon the type of route and design speed, are described below:

**Table 131.1.2 Controlling Criteria**

NHS with Design Speed > 50 mph	NHS with Design Speed < 50 mph	Non-NHS
Design Speed	Design Speed	(No Controlling Criteria)
Design Loading Structural Capacity	Design Loading Structural Capacity	
Lane Width		
Shoulder Width		
Horizontal Curve Radius		
Superelevation Rate		
Stopping Sight Distance		
Maximum <u>Profile</u> Grade		
Cross Slope		
Vertical Clearance		

A ~~MoDOT (only) approved~~ design exception approved only by MoDOT is required for all other non-complying design elements on projects which are designated for federal involvement for design exceptions and for all non-complying design elements on all ~~of~~ other projects not designated for federal involvement for design exceptions.

### 131.1.3 Approval Requirements

**Table 131.1.3 Design Exception Required Approvals**

Category	PODI Designated	Controlling Criteria*	FHWA	MoDOT
NHS	Yes	Yes	✓	✓
		No		✓
	No	Yes or No		✓
Non-NHS	Yes or No	N/A		✓
* Applicable Controlling Criteria as indicated in EPG 131.1.2.				

#### 131.1.3.1 Projects of Divisional Interest (PODI)

See [EPG 123.1.1 FHWA Oversight - National Highway System](#) for information on federal involvement on projects and for the PODI matrix.

### 131.1.4 The Design Exception Process

Requests for design exceptions are submitted when the need first arises; however, they may be submitted at any time and specifically along with the [conceptual study](#), [preliminary plan](#), right of way certification, or [final plans](#). All design exceptions should be approved prior to and submitted with the plans, specifications, and estimate (PS&E). In general, it is best to identify, ~~and~~ consider, ~~and~~ execute the design exception as early as practical in the design process. When a design change is required during construction, the Resident Engineer should contact the Transportation Project Manager (TPM). If that design change has elements that do not meet design standards, a design exception is required. The normal design exception process is followed.

When the need for a design exception has been identified, the ~~project manager~~ TPM, Structural Project Manager ([SPM](#)), or consultant representative is responsible for completing the standard [Design Exception Information Form](#) ~~(form)~~. The form must include a detailed description of the rationale for the change and the appropriate supporting documentation to satisfactorily justify the decision and document any mitigation efforts associated with varying from the engineering policy. ~~Examples of~~

~~approved Design Exceptions can be found here<provide link>. (Please note that~~  
pPrevious approval of an item should not be considered approval of the item on any future project. Approval for future projects must be sought on a case-by-case basis.)

Project managers (consultant, transportation, or ~~bridge~~structural) and their design staff should recognize the importance of an open and transparent decision making process while considering the suitability and appropriateness of a given design element that is not consistent with ~~our~~ current policies. Since ~~our~~ engineering policy is established through a collaborative effort, it is critical to engage all appropriate staff when making the decision not to meet ~~our~~ policies. While completing the form, communication with the appropriate staff, including the ~~DLE~~Design Liaison Engineer, a representative of any affected MoDOT division and FHWA (when applicable), is critical to ensure efficient and effective review and approval. For efficient processing and to avoid delays, this communication should occur prior to the formal submittal. Depending upon the item being excepted and the type of project, the appropriate review staff and signatory parties will vary.

Central Office staff should be consulted and provide review of the draft design exception prior to district approval. ~~A link to the electronic copy of every fully approved design exception is provided to the Central Office Design Division and Central Office Bridge Division, as appropriate. Design exceptions involving safety related items (see EPG 131.1.5) should be reviewed by the District Traffic Engineer and/or Highway Safety and Traffic Division prior to district approval. For design-bid-build projects, a~~ final copy of the design exception is saved in [eProjects](#) using the appropriate content type: ~~DE Letting Documents~~Design Exceptions, with all necessary checkboxes for Type of Exception checked. Staff should include any pertinent information in the Comments Section within the eProjects metadata. ~~For design-build projects, a final copy of approved design exceptions incorporated into the project are~~ saved in the design-build projects SharePoint site in an Approved Design Exceptions folder.

PODI design exceptions are processed through the ~~DLE~~Design Liaisons for the State Design Engineer and FHWA signatures of approval. The ~~DLE~~Design Liaisons provides the electronic copy of the fully approved design exception back to the IPM for placement in eProjects.

~~It should be noted that t~~The Federal Highway Administration (FHWA) reserves the right to audit the design exceptions of any federal aid project regardless of level of oversight.

#### **131.1.4.1 The Development, Concurrence and Approval Process**

In addition to the applicable process requirements described below, vertical clearance design exceptions on the interstate must also follow the additional requirement described in [EPG 131.1.7 Deficient Vertical Clearances on Interstates](#).

##### 131.1.4.1.1 Roadway Design Exceptions

Upon the core team's determination that a design exception is warranted, the following process should be used for design exception submittals relating to roadway items only:

Conceptual Approval:

- 1) The ~~Transportation Project Manager (TPM)~~ working with the Consultant Project Manager, if applicable, submits the design exception information form, ~~submittal letter~~ and supporting information to the ~~Design Liaison Engineer (DLE)~~, the District Design Engineer (DDE), FHWA (if applicable) and any other pertinent district and division staff.
- 2) The contacted division and district representatives will respond with any necessary comments or concerns, request additional information if necessary, or will request an opportunity to meet and discuss the issue.
- 3) The TPM works with staff to appropriately address or resolve comments, concerns, or objections and finalizes the design exception.
- 4) The TPM submits the design exception including all supporting documentation in a single pdf file for signature according to the flowchart below.

Formal Approval:

Signatures for approval should be obtained in accordance with the following flowchart:

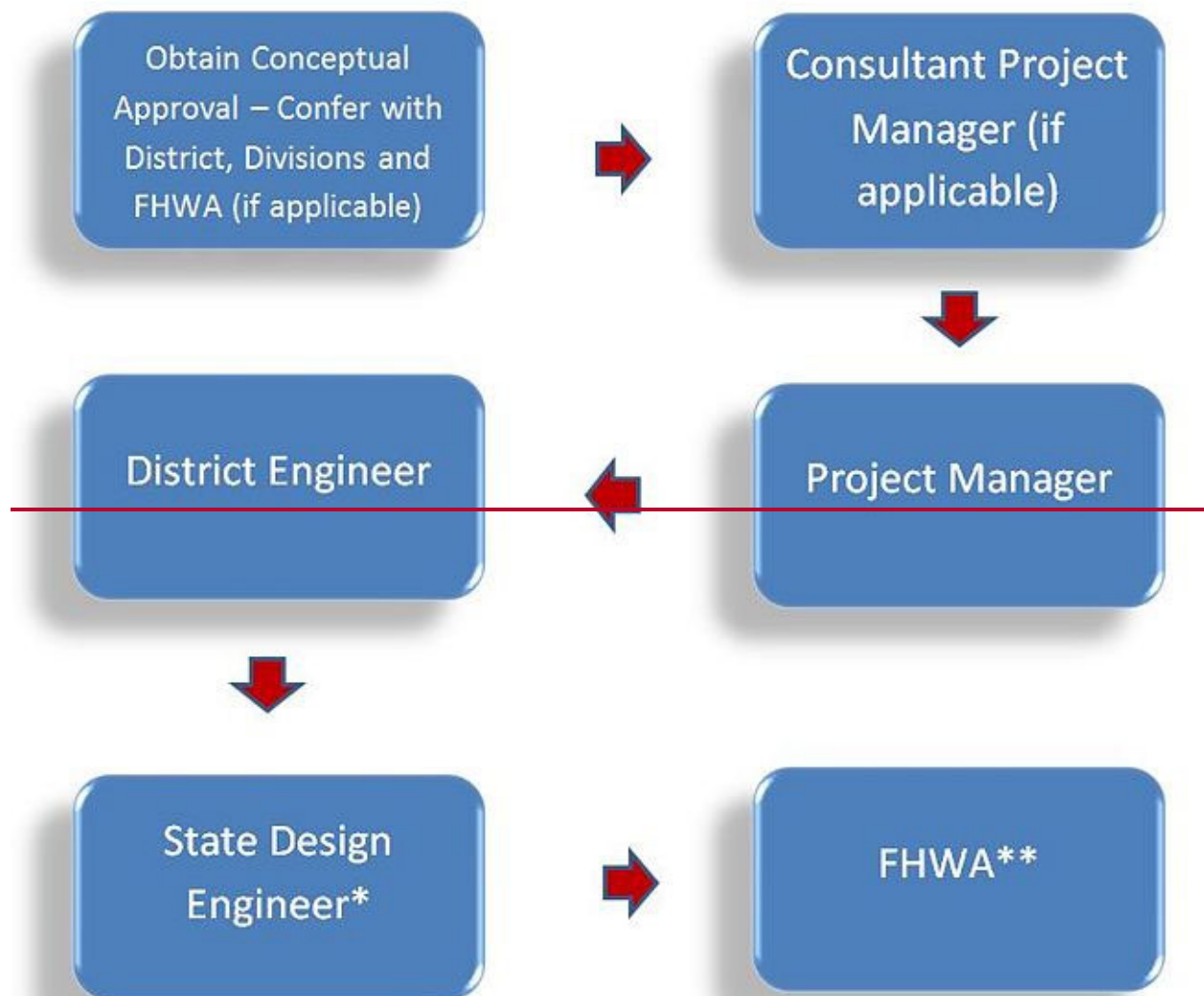

~~Route as appropriate to obtain approvals in the appropriate order.~~

~~\* Note: Concurrence only if not indicated that federal approval is required in accordance with EPG 131.1.3 and the PODI matrix.~~

~~\*\* Note: Omitted if not indicated that federal approval is required in accordance with EPG 131.1.3 and the PODI matrix.~~

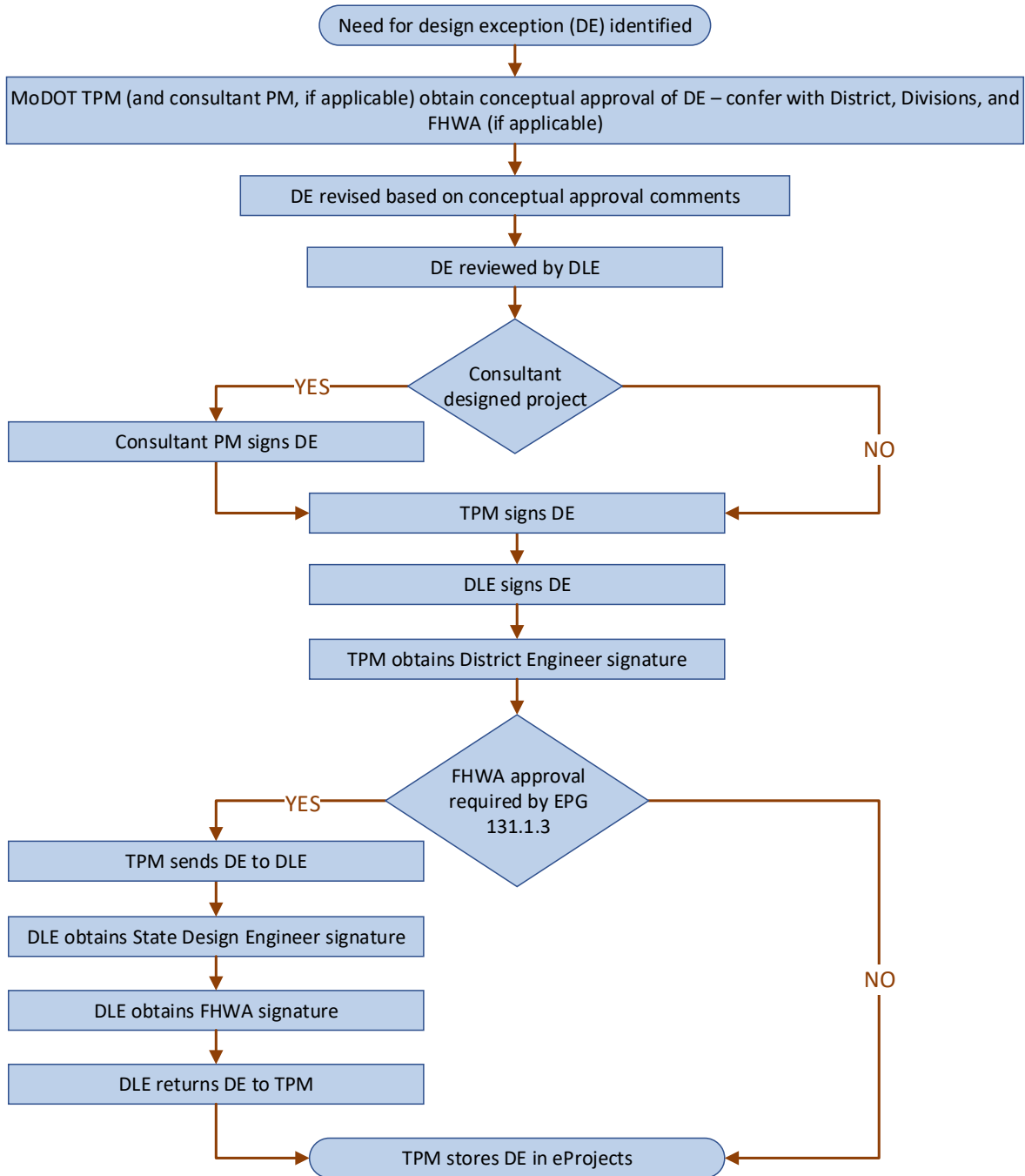

**Figure 131.1.4.1. Roadway Design Exception Process**

131.1.4.1.2 Bridge Design Exceptions

The following process should be used for design exception submittals relating to bridge items:

Conceptual Approval:

1. The ~~Structural Project Manager (SPM)~~, or the ~~Structural Liaison Engineer (SLE)~~ working with the Consultant Project Manager submits the design exception form, ~~submittal letter and supporting information~~ to the Assistant State Bridge Engineer, the ~~Design Liaison Engineer (DLE)~~, the Transportation Project Manager, FHWA (if applicable) and any other pertinent district and division staff.
2. The contacted division and district representatives will respond with any necessary comments or concerns, request additional information if necessary, or will request an opportunity to meet and discuss the issue (if significant objection is determined).
3. The SPM/SLE works with staff to appropriately address or resolve comments, concerns, or objections and finalizes the design exception.
4. The SPM/SLE submits the design exception including all supporting documentation in a single pdf file for signature according to the flowchart below.

Formal Approval:

Signatures for approval should be obtained in accordance with the following flowchart:

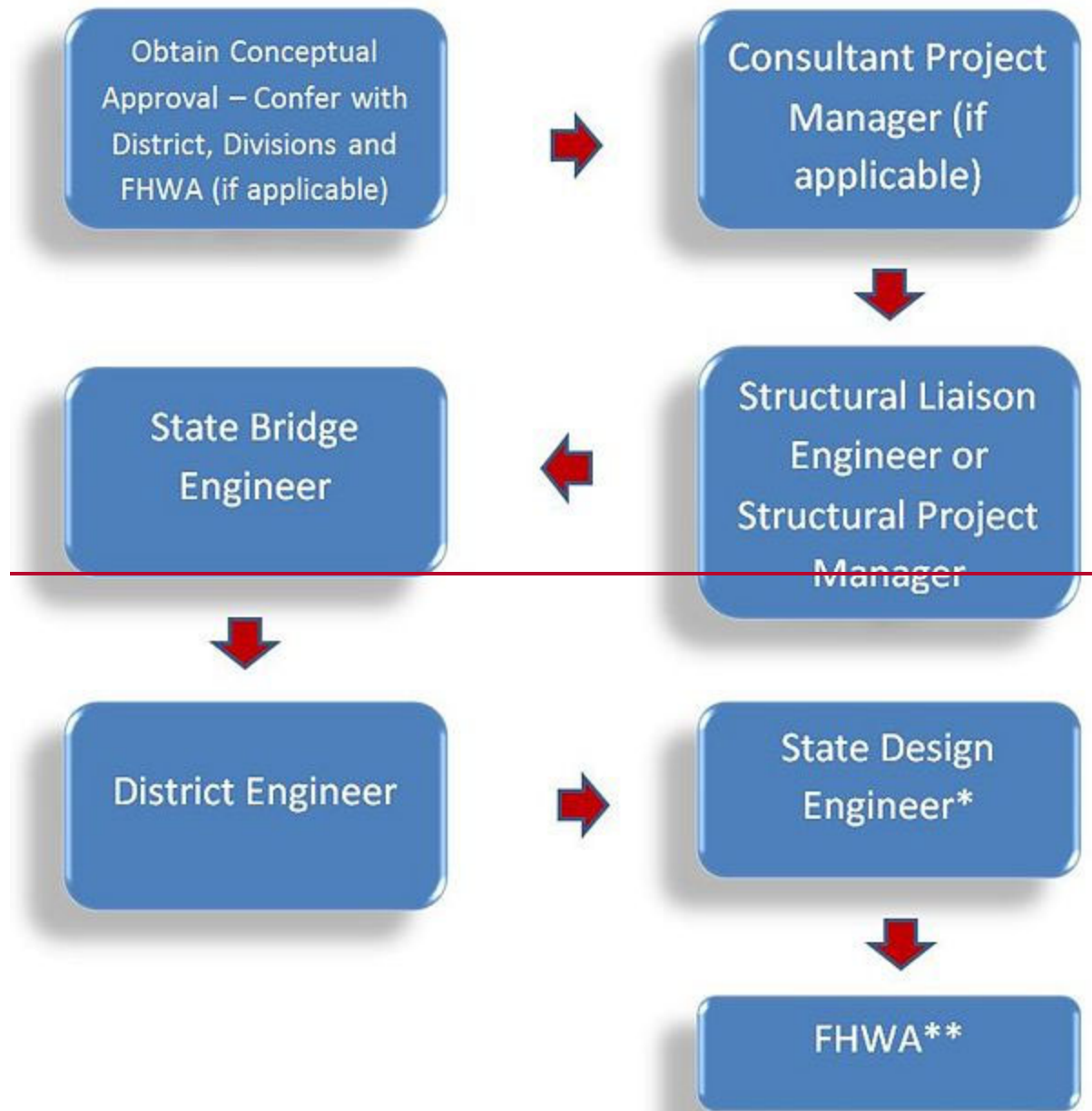

~~Route as appropriate to obtain approvals in the appropriate order.~~

~~\* Note: Concurrence only if not indicated that federal approval is required in accordance with EPG 131.1.3 and the PODI matrix.~~

~~\*\* Note: Omitted if not indicated that federal approval is required in accordance with EPG 131.1.3 and the PODI matrix.~~

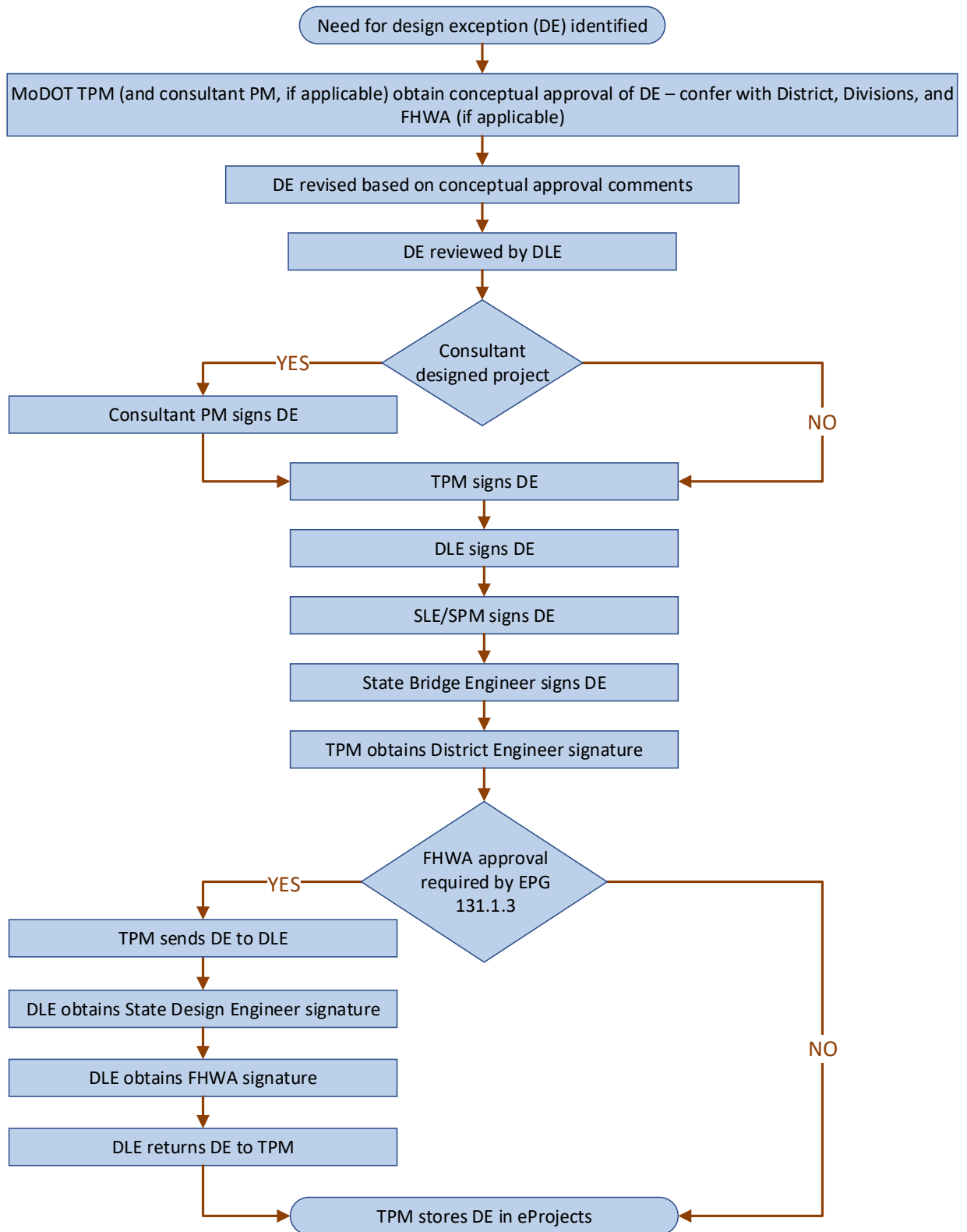

**Figure 134.1.4.2.** Bridge Design Exception Process

### 131.1.4.1.3 Both Roadway and Bridge Item Related Design Exceptions

Occasionally, both roadway and bridge items will need to be included. In these instances, the TPM and the SLE/S~~L~~PM should agree to a single point of contact for the review, concurrence, and approval of the design exception and will ensure that the appropriate staff members are properly engaged throughout the process.

### 131.1.4.2 Issue Resolution

The review and concurrence process is intended to avoid any significant objections, questions or concerns during the approval process, however, occasionally these issues may arise. In this instance, the design exception approval process may be put on hold until the issue can be resolved by the appropriate staff members. The TPM or SLE/S~~L~~PM will remain the primary contact to address any request for additional information or consideration.

### ~~131.1.4.3 Design Exception Numbering and Logging~~

~~As design exceptions serve as the permanent record of the design decision, providing a design exception numbering and logging system will benefit tracking the submittal and return of each exception and to ensure that all design exceptions are acknowledged and accounted for. The preferred design exception numbering system is the job number followed by a sequential number for each design exception. For example, the first roadway design exception for project JXPXXXX would be Design Exception (DE) # JXPXXXX-R1. The second would be JXPXXXX-R2, and so forth. The first bridge design exception for project JXPXXXX would be DE# JXPXXXX-B1. If a design exception includes both roadway and bridge items, it will be numbered and logged according to who initiates the design exception. The logging system in each project file should indicate the design exception number and the date submitted and date received. If a design exception is not approved, the number should be recorded and noted that it was not approved. The next design exception would be numbered with the next available number. Additionally, as a best management practice, the design exception log and the design exceptions themselves may be located in the project file or a project SharePoint site.~~

### 131.1.5 ~~Required~~ Completing the Design Exception Information Form for Design Exception

Whenever ~~the~~ engineering policy cannot be met, data for only those non-standard items is listed ~~on the form~~. This data includes a brief description of the project and the improvement goals that are being attempted. This information is required since the context of the project often helps in deciding if approval of the exception is appropriate. Additionally, the data should include the details related to ~~the location (limits) associated with the solution,~~ the existing ~~feature condition~~ (if applicable), the ~~desired standard~~ design criteria for that feature, ~~and~~ the proposed ~~design~~ solution, ~~and the location (limits) associated with the solution~~. The column shown for ~~the~~ existing ~~features condition~~ is not applicable to new construction. The appropriate values for desired design criteria are shown in the ~~second~~ ~~third~~ column. The design criteria for new

construction on rural and urban highways are stated in individual articles pertaining to each geometric element discussed in the [EPG 200 Geometrics](#) articles. Design criteria for 3R and 4R projects are discussed in [EPG 128 Conceptual Studies](#). The criteria for proper access management can be found in [EPG 940 Access Management](#).

All design exceptions must suitably explain the justification for the exception. It is imperative that this justification be sufficiently complete to clearly reflect that the designer exercised reasonable care in the selection of a particular highway design. Design exceptions often arise because it is impractical or impossible to reasonably meet engineering policy. The justification may include appropriate economic analysis, discussion of applicable accident location and type or discussion of avoidance of [Section 4\(f\)](#) or [Section 6\(f\)](#) lands. The justification supports the concept that maximum service and safety benefits were realized for the cost invested. Engineering judgment is used when balancing the economic and engineering reasons for the justification. A design exception is based on sound engineering judgment rather than being solely an attempt to save cost.

In general, all design exceptions should include the following:

- Specific design criteria that will not be met.
- Existing roadway characteristics.
- Alternatives considered.
- Comparison of the safety and operational performance of the roadway and other impacts such as right-of-way, community, environmental, cost, and usability by all modes of transportation.
- Proposed mitigation measures.
- Compatibility with adjacent sections of roadway.

Note: The level of analysis should be commensurate with the complexity of the project.

In addition to the information above, exceptions for the Design Speed and Design Loading Structural Capacity criteria should include the following information:

- Design Speed exceptions:
  - Length of section with reduced design speed compared to overall length of project
  - Measures used in transitions to adjacent sections with higher or lower design or operating speeds.
- Design Loading Structural Capacity exceptions:
  - Verification of safe load-carrying capacity (load rating) for all state unrestricted legal loads or routine permit loads, and in the case of bridges and tunnels on the interstate, all federal legal loads.

### ~~Safety related features~~

~~If the design exception request involves any features that are safety related, then sufficient crash data and history is attached to the request to support the reasons for justification. For design exceptions related to existing conditions, a review of the existing condition crash history is required. The review should focus on crash types to which the design element may relate with a special consideration to fatal and injury crashes. A summary report of the crash information is acceptable if the volume of the data is~~

excessive. Specific attention should be paid to design elements that have a direct impact on safety. Examples of ~~safety-related features such design elements~~ include, but are not limited to, the following: design speed, stopping sight distance, passing sight distance, lane width, shoulder width, shoulder type, rumble strips, turn lanes, access management requirements, ~~bridge width~~, bridge approach rail, horizontal alignment, vertical alignment, grade, horizontal clearance, vertical clearance, guardrail, etc. ~~Any other items that may be perceived as a safety concern will also follow these requirements.~~

In addition, if the design exception request involves safety related features that are adequately addressed in the AASHTO *Highway Safety Manual*, then documentation of the exception should include a safety analysis as described in the manual. Typically, this process will involve two primary determinations:

- Calculate the expected change in crashes from existing conditions to standard design conditions
- Calculate the expected change in crashes from existing conditions to the proposed design.

The proposed design should take into account any design exceptions as well as any additional safety features above and beyond the standard design.

By making these two determinations, a quantitative safety comparison can be made between existing conditions, the standard design, and the proposed design. This information, along with other project considerations, can be used to help determine the best design alternative. A list of features currently addressed by the manual include: lane width, shoulder width, shoulder type, center line rumble strips, horizontal alignment (length, radius), grade, roadside hazard rating, fixed objects, driveway density, median width, sideslope, lighting, intersection skew angle and turn lanes. Not all features in the manual are addressed for each every facility type. If a feature is not addressed in the manual, a statement should be included on the design exception stating that fact. For features not addressed in the HSM, a qualitative discussion may be included.

### 131.1.6 Revising an Approved Design Exception

Changes in project scope or design criteria can result in changes to design exceptions that have previously been ~~considered approved~~. In these cases, a revised design exception must be completed and approved (as described above). The reasoning on revised design exceptions should address the changes and an explanation of the circumstances leading to the revision. The original design exception should accompany the revised information in order to illustrate the changes. ~~The transmittal letter should address the changes and an explanation of the circumstances leading to the revision.~~

### 131.1.7 Deficient Vertical Clearances on Interstates

Maintaining the integrity of interstates for national defense purposes has long been recognized. Interstates are intended to be constructed and maintained to meet AASHTO Policy as stated in *A Policy on Design Standards - Interstate System*, which is incorporated by reference in [23 CFR 625](#). Maintaining standard vertical clearances to the extent possible for defense mobilization is considered particularly important and is a focus at the national level. As a result, the [FHWA](#) has agreed that all exceptions to a 16

~~foot-~~ (16') vertical clearance standard for the rural ~~interstate routes and certain or on a single routings on the urban interstates~~ route through urban areas must be coordinated with the Surface Deployment and Distribution Command Transportation Engineering Agency (SDDCTEA) of the Department of Defense. This coordination applies whether it is a new construction project, a project that does not provide for the correction of an existing substandard condition, or a project that creates a substandard condition at an existing structure. The steps involved are:

1. For a vertical clearance over any interstate highway that will be less than 16 ft. meeting the above criteria, the district submits to the [Design Division](#) a completed SDDCTEA Interstate Vertical Clearance Coordination Form along with a Design Exception for vertical clearance.
- 2 The ~~DLE~~[Design Liaison Engineer](#) emails the Bridge Inventory Analysts and requests the Structure NBI number for box 2 on the Vertical Clearance Design Exception Coordination with SDDCTEA Form.
3. Concurrent with the submission or routing of the Design Exception, the ~~DLE~~[Design Liaison Engineer](#) submits the ~~SDDCTEA Form~~[form](#) to the SDDCTEA and copies FHWA. This may be done electronically using the contact information on the [Vertical Clearance Design Exception Coordination with SDDCTEA](#).
4. A response from SDDCTEA should occur within 10 working days following receipt of the coordination request. Receipt of the request can be verified with SDDCTEA via telephone, ~~or fax,~~ [or email](#). If there is no response after 10 working days following receipt, it can be determined that SDDCTEA does not have any concerns about the proposed exception.
5. The ~~DLE~~[Design Liaison Engineer](#) informs FHWA as to the final outcome of the SDDCTEA request.

## 236.5.12 Excess Land Conveyances & Relinquishments – ~~Regulated~~ Utilities

---

All conveyances and relinquishments of Commission-owned property shall be evaluated for the existence of any ~~regulated~~ utility facilities located within the areas to be conveyed or relinquished. ~~Regulated utility facilities consist of the regulated utilities as defined by the Public Service Commission. By law, regulated utilities have the right to locate within Commission-owned property. Therefore, a~~ A conveyance or relinquishment of Commission-owned property may have implications to the utility facilities, and the utility ~~providers who own such facilities~~ owners, when the Commission no longer controls the property. It is important to maintain the continuity of utility facilities for the general public; therefore, to identify and minimize potential impacts, MoDOT shall involve utility ~~providers~~ owners in the conveyance and relinquishment processes.

### 236.5.12.1 Excess Land Conveyances Utilities

MoDOT shall only recommend that a property be declared excess upon satisfactorily addressing the utility impacts. Whether MoDOT or an external party initiates the conveyance of excess property, utility impacts shall be adequately addressed by using one of the following methods:

1. Each utility ~~facility~~ will be relocated by permit into a new utility corridor retained by the Commission.
2. Each utility ~~facility~~ will remain in place with the benefit of a non-exclusive permanent utility easement.

If the Commission holds fee simple title to the property, the Commission shall convey a non-exclusive permanent utility easement to each utility ~~provider~~ owner.

If the Commission holds a less than fee simple title interest in the property, MoDOT shall facilitate the conveyance of a non-exclusive permanent utility easement from the party acquiring the property to each utility ~~provider~~ owner.

3. Each utility ~~facility~~ will be relocated to another portion of the property being conveyed.

If the Commission holds fee simple title to the property, the Commission shall convey a non-exclusive permanent utility easement to each utility ~~provider~~ owner.

If the Commission holds a less than fee simple title interest in the property, MoDOT shall facilitate the conveyance of a non-exclusive permanent utility easement from the party acquiring the property to each utility ~~provider~~ owner.

4. Each utility ~~facility~~ will be relocated onto a portion of the property already owned by the party acquiring the Commission-owned property, with the benefit of a non-exclusive permanent easement. (MoDOT shall facilitate the conveyance of a non-exclusive permanent utility easement from the party acquiring the property to each utility ~~provider~~ owner.)

5. A three-party negotiated settlement taking into consideration the overall value of the proposed transaction.

6. Additional options to address utility impacts may be utilized with approval from the Asst. to the State Design Engineer - Right of Way.

7. A parcel conveyed to a county or municipality shall include a clause similar to the following in the deed from the Commission to the county or municipality:

"Grantee, by acceptance of this conveyance, covenants and agrees for itself, its successors and assigns, to allow known or unknown utility facilities currently located on the property, whether of record or not, to remain on the property, and to grant the current and subsequent owners of those facilities the right to maintain, construct and reconstruct the facilities and their appurtenances over, under, and across the land herein conveyed, along with the right of ingress and egress across the land herein conveyed to and from those facilities."

### **236.5.12.2 Road Relinquishment Utilities**

MoDOT shall only recommend the relinquishment of roadways through the [Change in Route Status Report](#) upon satisfactorily addressing the **utility** impacts **to utility facilities**. If the roadway will be relinquished to a local public transportation authority, with the intent that it continues to be used as a public roadway, **the following** a clause **similar to the following** shall be included in the deed from the Commission to the local public transportation authority:

"Grantee, by acceptance of this conveyance, covenants and agrees for itself, its successors and assigns, to allow known or unknown utility facilities currently located on the property, whether of record or not, to remain on the property, and to grant the current and subsequent owners of those facilities the right to maintain, construct and reconstruct the facilities and their appurtenances over, under, and across the land herein conveyed, along with the right of ingress and egress across the land herein conveyed to and from those utilities."

Proposed roadway relinquishments to private entities shall be reviewed in a manner consistent with the conveyance of excess property described in [EPG 236.5.3 Asset Management Committee](#)

This replaces the current EPG 643 Utility Procedures

## 643 Utility Procedures

---

**Utility Accommodation Policy:** State DOTs are required to develop policies and procedures pertaining to the use, accommodation, and/or relocation of public and private utility facilities on highway rights-of way using Federal-aid highway funds. State DOTs are required to develop, maintain, and obtain FHWA approval of their Utility Accommodation Policy (UAP) (23 CFR section 645.215). This EPG article 643 and subarticles 643.1 through 643.3 are Missouri Department of Transportation (MoDOT)'s Utility Accommodation Policy. Text in EPG 643 consolidates various federal and state statutes and rules into a single, cohesive, workable policy to outline processes for MoDOT staff and utility owners.

**Delegation of Work:** Each MoDOT district is responsible for ensuring implementation of the UAP outlined in the subsequent EPG articles. Each district can create its own organization for whom is responsible for the work including between divisions and job titles. Work responsibilities within this article and subarticles are generic where possible. If a specific title is included, that title has sole responsibility for that item of work.

Additional Information

[23 CFR 645](#)

[7 CSR 10-30](#)

### **Subcategories**

This category has the following subcategories.

643.1 Utility Location

643.2 Utilities in Program Delivery

643.3 Reserved for Future Use

643.4 Railroads

## 643.1 Utility Location

---

The information in this article provides a uniform system for regulating the location, construction, maintenance, removal, and relocation of utility facilities on the right of way of roadways located on the state highway system. It also provides for the facilitation of construction and maintenance of these roadways. Any location or relocation of utility facilities contrary to this information is an interference with the construction, maintenance, or operation of a state highway and its right of way and is prohibited.

### 643.1.1 Permits

---

All utility owners are required to obtain a permit to work on Missouri Highway and Transportation Commission (Commission) right of way. A permit is required for original installation of the utility facility, on-going maintenance of the utility facility, or adjustments to a utility facility necessary to allow highway construction. Per [EPG 127.29.4.3](#), discharges of anything other than stormwater are

not permitted. A deposit or bond is required to ensure completion of the work in accordance with the permit issued. An [application for a permit](#) may be made on established forms specifically stating the nature of the work to be performed. Applications for permits may be obtained at any of the [seven \(7\) district highway offices](#) of the Commission, [MoDOT's website](#), or by requesting it from the office of the Missouri Highways and Transportation Commission in Jefferson City, Missouri. The application for a permit will specifically state the nature of the work to be performed, what specific type of utility facility is to be installed, and, if necessary, the timeframe of any temporary use. Piping of any type of sewage or waste will only be allowed providing any permitting by a regulatory agency, such as Missouri Department of Natural Resources, can be provided. Prior to obtaining a permit through MoDOT's permit system, a utility owner will be required to provide a bond to ensure satisfactory work and complete a TR50 Electronic Signature Agreement with the Commission. The name of the utility owner must match on the bond, TR50, and in the permit system. More information on permitting can be found in [EPG 941](#).

### **643.1.1.1 Emergency Work**

When emergency operations work is necessary, the damaged utility facility may be accessed immediately and without a permit by leaving the pavement at such points as may be necessary to effect emergency repairs, provided immediate notice is given to the Missouri State Highway Patrol and the district utilities staff for the district wherein the work will be performed, and a permit for emergency operations is requested immediately upon discovery of the need for emergency operations. A permit for emergency operations work is to be obtained as soon as practical, but in no event later than two (2) working days after the emergency operations work has commenced. Emergency operations include, but are not limited to, unplanned work in response to utility facilities being so damaged as to constitute an emergency situation directly affecting or endangering traffic on the highway or public health or safety.

### **643.1.1.2 Third-Party Inspection**

When a utility owner has a large number of projects in a given area or projects involving great complexity, MoDOT reserves the right to limit the number of permits open at any given time. With approval of the district utilities staff, a utility owner may hire a third-party inspector, at their cost. The third-party inspector will allow the utility owner to increase the number of permits open at any given time. The responsibility of the third-party inspector will be to ensure the installation of the utility facility proceeds in a manner consistent with the plans approved in the permit, including all work zone requirements and conformity with MoDOT's Standards and Specifications. The MoDOT approved third-party inspector will be listed in the permit. MoDOT may audit third-party inspections and revoke the right to use third-party inspections should the inspectors fail to perform their duties.

### **643.1.1.3 Abandoned Utility Facilities**

All utility facilities installed in Commission right of way are the property of the utility owner whether the utility facility is active or inactive. MoDOT may allow a utility facility to remain on Commission right of way whether the utility facility was abandoned for a MoDOT project or at the utility owner's discretion. MoDOT may place requirements (such as removing inactive fiber optic cables, grouting pipes, removing valves) on the utility owner as part of the process of abandoning a utility facility. Liability for damage to Commission right of way due to an abandoned facility remains the responsibility of the utility owner. In the event MoDOT requires the removal of the abandoned utility facility, responsibility for the cost of the removal will be determined per [EPG 643.2.8](#).

## 643.1.2 Definitions

---

**Bridge Attachment:** A bridge attachment is any utility facility, including communication lines and electrical lines, or any other utility facility of a similar nature that is fastened to a bridge for the purpose of spanning an obstacle.

**Clear zone:** The total roadside border area starting at the edge of the traveled way, available for safe use by errant vehicles. This area may consist of a shoulder, a recoverable slope, a non-recoverable slope, and/or the area at the toe of a non-recoverable slope available for safe use by an errant vehicle. Clear zone dimensions are provided in the current edition of American Association of State Highway Transportation Officials Roadside Design Guide.

**Ditch Line:** A line where the roadway ditch meets the back slope. It is located at the lowest point of a V-bottom ditch or furthest point from the roadway of a flat bottom ditch where the roadway slopes back to the existing ground line.

**Duct:** An enclosed tubular casing, or raceway, for protecting wires, lines, or cables that is often flexible or semi-rigid (1-3% diametric deflection). The casing, or raceway, is separate from the cable or conductor that passes through it.

**Encasement:** The term encasement means the placing of an installation around and outside of an underground facility consisting of a larger conduit that permits the removal and replacement of the facility. An alternate to the conduit type encasement is reinforced concrete poured around the utility facility. Utility owners are allowed to use any types of material as a carrier and encasement for its facilities as expressly provided for in the permit issued for the installation of the utility facility.

**Freeway:** A divided arterial highway with full control of access.

**Highway:** Any public way for vehicular travel, including the entire area within the right of way and related facilities constructed or improved and maintained by the Missouri Highways and Transportation Commission (MHTC) acting through the Missouri Department of Transportation (MoDOT).

**Interchange Limits:** For the uniform handling of utility installations only, the limits of an interchange are the outside ramp curve points. See [EPG Figure 643.1.1](#) for an example.

**Interstate System or Other Freeways/Expressways:** Interstate highways and highways with fully controlled access.

**Major Routes (Interstates, Freeways/Expressways and Principal Arterials):** The major highway system is all routes functionally classified as principal arterials. The principal arterial system provides for statewide or interstate movement of traffic. The major roads in Missouri total approximately 5,500 centerline miles.

**Minor Routes:** The minor highway system is all routes functionally classified as minor arterials or collectors. These routes mainly serve local transportation needs. The minor roads in Missouri total approximately 28,400 centerline miles.

**Normal Right of Way Line:** An imaginary line that connects sudden breaks in the major right of way points for roadways. Sight distance right of way points (triangles) at roadway intersections are not to be considered as sudden breaks for determining normal right of way.

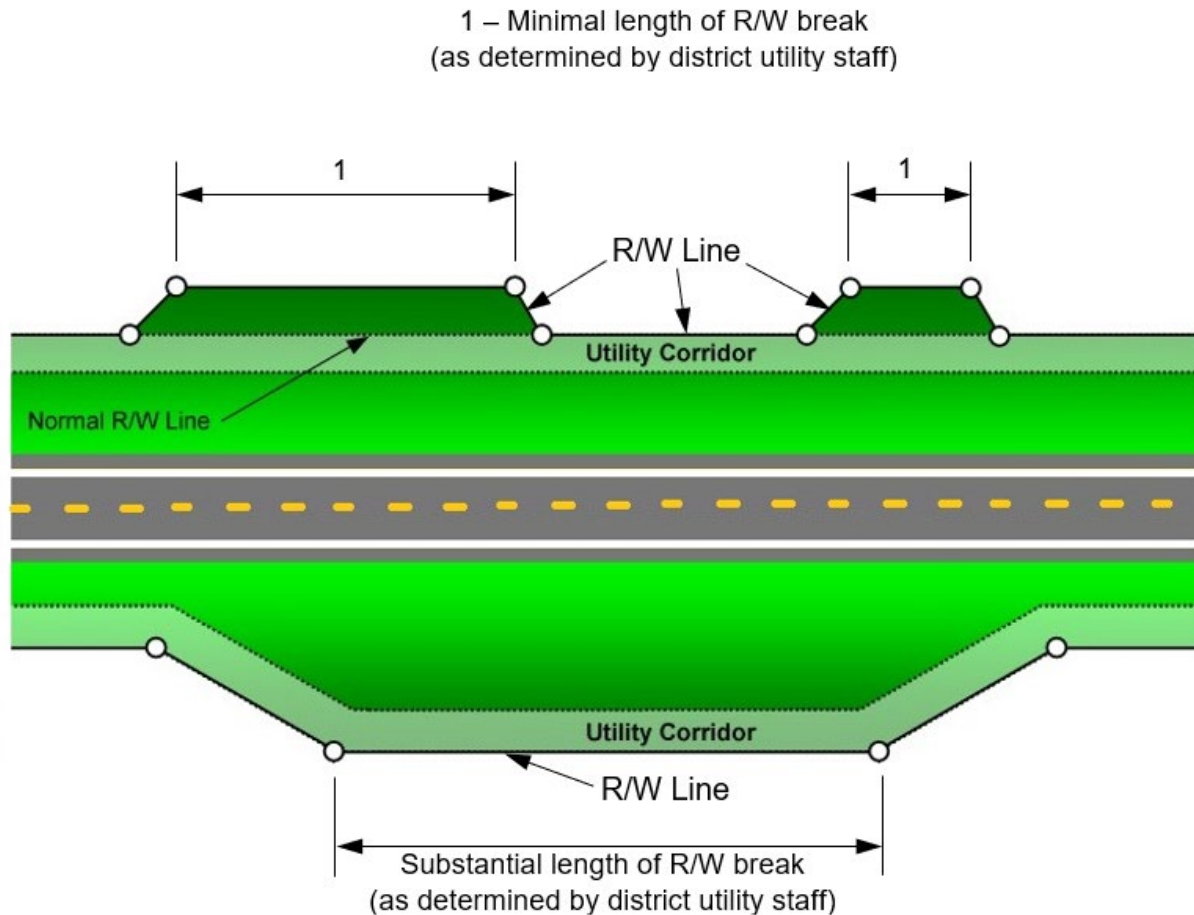

**Figure 643.1.2 Normal Right of Way Line.**

**Private Lines:** Privately owned utility facilities which convey or transmit the commodities outlined in the definition of utility facility of this section but devoted exclusively to private use.

**Scenic Enhancement Areas:** Scenic enhancement areas include areas acquired or so designated as scenic strips, overlooks, rest areas, recreation areas, and the right of way of adjacent roadways and the right of way of roadways that pass through public parks and historic sites as described under 23 USC 138.

**Utility Corridor:** An area established for the placement of utility facilities parallel to the normal right of way line.

**Utility Facility:** Privately, publicly, or cooperatively owned line, facility, or system for producing, transmitting, or distributing communications, cable television, power, electricity, light, heat, gas, oil, crude products, water, steam, waste, storm water not connected with highway drainage or any other similar commodity, including any fire or police signal system or street lighting system which directly or indirectly serves the public and does not include privately owned facilities devoted exclusively to private use. The term "utility facility" includes those facilities used solely by the utility owner that are a part of its operating plant.

**Utility Owner:** The utility owner is the utility company, inclusive of any wholly owned or controlled subsidiary, or city or county which owns utility facilities. The term also includes those government

agencies that lease a utility facility for its own use or otherwise dedicated solely to governmental use.

**Variance:** A one- (1-) time deviation from the requirements for location or relocation of utility facilities on the right of way of highways in the state highway system as established in [Title 7 Code of State Regulations 10-3](#), requested by the utility, and approved by a MoDOT District Design Engineer.

## 643.1.3 Location of Utility Facilities

---

Utility facilities paralleling the roadway should be installed in the utility corridor except as outlined below. The utility corridor is the space for all utility owners generally within six feet (6') of the normal right of way line. When considering if the current utility corridor is available to expand from six feet (6') to as much as twelve feet (12'), MoDOT determines if the expansion is warranted. In making the determination, MoDOT will consider the existing utilization of the original six feet (6') corridor. Poles must remain within two feet (2') of the normal right of way line unless approved by a variance. The utility corridor will only be expanded beyond six feet (6') if the original six feet (6') corridor is fully utilized and additional space would be required to accommodate additional utility facilities. Acquisition of additional right of way to establish a twelve feet (12') corridor is not required on highway construction projects. For depths for underground utility facilities, see EPG [643.1.4.1](#).

Utility facilities crossing the roadway should be installed as close to ninety degrees (90°) to the centerline of the roadway as possible and based on the guidelines below depending on the type of roadway.

### 643.1.3.1 Interstate System or Other Major Freeways/Expressways

The installation of all utility facilities on highways of the Interstate System or other major freeways/expressways with fully controlled access are to be installed, serviced, and maintained without entering or leaving the roadway and ramps except at points approved by MoDOT for that purpose and without parking any equipment or storing materials upon the medians, roadway and ramps, or shoulders of the roadways. Cutting or damaging the pavement or paved shoulders is not permitted. New service connections to existing parallel utility facilities are to be permitted only where an outer roadway exists and then only where access is permitted by the Commission. Careful consideration will be given to the location of guys, anchors, braces, and other supports. Generally, good design practice will provide that appurtenances be located at right of way jogs, along intersecting road right of way, or at other similar acceptable locations, so that encroachment is held to an absolute minimum.

No utility facilities will be permitted within the interchange limits of an interchange between fully limited access highways where planned or existing. Utility facilities within the interchange limits of an interchange with a non-access controlled highway will be permitted only along the minor road, provided that all construction, service, and maintenance can be performed from the minor road. Manholes and poles must be located beyond the ramp termini.

For structures carrying or over interstates or other major freeways/expressways, see EPG [643.1.5](#).

#### 643.1.3.1.1 Utility Facilities Crossing the Interstate or Other Major Freeways/Expressways

*643.1.3.1.1.1 Overhead Crossings of the Interstate or Other Major Freeways/Expressways*  
Overhead crossings of utility facilities are permitted only for power transmission and distribution lines and for multiple circuit communication lines where an underground installation is not economically feasible. Supports for existing utility facilities crossing overhead may remain on the right of way

provided they are near the right of way line regardless of the presence of an outer road. Supports for new overhead utility facilities crossing overhead may be located on the right of way near the right of way line where an outer roadway exists and are to be located off the right of way where no outer roadway exists. Overhead service crossings are only permitted in isolated cases for residential or commercial establishments when the denial of the crossing would require construction of more than 1,200 feet (1,200') of utility line to provide the service. Main or distribution line crossings are required to serve a general area other than isolated cases.

#### ***643.1.3.1.1.2 Underground Crossings of the Interstate or Other Major Freeways/Expressways***

Underground crossings of utility facilities are to be continuously encased under the pavement, medians, ramps, and shoulders with the casing extending to the toe of the fill slopes or to the ditch line. In curbed sections, encasement should extend outside the outer curb of the roadways a distance equal to the depth of the encasement at the curb line. Where installed by open trench through unpaved areas, detector tape should be placed approximately one foot (1') above the encasement. Where an interstate or other major freeway has a parallel outer roadway, encasement should be continuous under all roadways within the right of way.

Manholes or vent pipes are to be located at the right of way line or adjacent to the outer roadway.

For fiber optic cable, encasement should extend from within six feet (6') of one right of way line to within six feet (6') of the other right of way line.

Exceptions may be made for encasement as listed in [EPG 643.1.4.2](#).

#### ***643.1.3.1.1.3 Parallel Installations along the Interstate or Other Major Freeways/Expressways***

New parallel installations on the right of way may be permitted only where an outer roadway exists, provided that poles are within two feet (2') of the normal right of way line and underground utility facilities are within the utility corridor, and provided that the utility facility can be installed and maintained between the outer roadway and the right of way line. Existing overhead or underground utility facilities that parallel an existing roadway which will be incorporated into a completed highway as an outer roadway may remain in place if all maintenance and service can be performed from an outer roadway and the existing location does not interfere with construction, maintenance, or operation of the completed highway. If an existing parallel utility facility needs to be relocated so as to not interfere with the construction, maintenance, or operation of the completed interstate or other major freeway, poles may be located within five feet (5') of the right of way line.

Underground utility facilities are expected to be buried within the utility corridor of sight distance triangles (SDTs) at roadway intersections unless granted a variance. Overhead utility facilities may be allowed to span intersecting roadways with SDTs provided the poles, or supports, are located outside the SDT.

#### ***643.1.3.1.1.4 Sanitary Sewers within the Right of Way of Interstates or Other Major Freeways/Expressways***

New installations of sanitary sewers should follow the applicable guidelines for either underground crossings or parallel installations as appropriate. Existing gravity trunk sanitary sewers should be considered individually and removed or left in place contingent upon its age, condition, feasibility of moving, and maintenance access. Encasement of existing trunk sewers left in place may be required for questionable condition, protection during construction, or heavy fills.

Manholes should be relocated to the right of way lines or adjacent to an outer roadway.

## 643.1.3.2 Major Routes

For structures carrying or over major routes, see [EPG 643.1.5](#).

### 643.1.3.2.1 Major Routes with Partially Controlled Access Right of Way

The installation of all utility facilities on highways with partially controlled access right of way are to be installed, serviced, and maintained without entering or leaving the roadway and ramps except at points approved by MoDOT for that purpose and without parking any equipment or storing materials upon the medians, roadway and ramps, or shoulders of the roadways. Cutting or damaging the pavement or paved shoulders is not permitted. Equipment or materials stored within the right of way must be protected by longitudinal barrier or be located outside the clear zone. New service connections to existing parallel utility facilities are to be permitted only where granted by the Commission.

No utility facilities will be permitted within the interchange limits of an interchange between fully limited access highways where planned or existing. Utility facilities within the interchange limits of an interchange with a non-access controlled highway will be permitted only along the minor road, provided that all construction, service, and maintenance can be performed from the minor road. Manholes and poles must be located beyond the ramp termini.

### 643.1.3.2.2 Major Routes with Normal Access Right of Way

All new utility facilities will be installed and maintained without cutting or damaging the pavement or paved shoulders except in the event underlying rock formations or other obstructions are encountered that prevent boring or pushing operations. A variance may be granted for pavement cuts when the need is established. Pavement cuts may only be made by permits issued when it is impractical to otherwise service and maintain the facility. The installation of all utility facilities is to be installed without parking any equipment or storing materials upon the medians, roadway and ramps, or shoulders of the roadways. Equipment or materials stored within the right of way must be protected by longitudinal barrier or be located outside the clear zone.

### 643.1.3.2.3 Utility Facilities Crossing Major Routes

#### 643.1.3.2.3.1 Overhead Crossings of Major Routes

Supports for utility facilities crossing overhead should be located as near the right of way line as possible. For major routes with controlled access right of way, new overhead service crossings may be permitted in isolated cases for residential or commercial establishments where the denial of such crossings would require the construction of more than 1,200 feet (1,200') of utility line to provide the same service. For major routes with normal access right of way, there is no restriction on the placement of service crossings.

#### 643.1.3.2.3.2 Underground Crossings of Major Routes

Underground crossings of utility facilities are to be continuously encased under the pavement, medians, ramps, and shoulders with the casing extending to the toe of the fill slopes or to the ditch line. In curbed sections, encasement should extend outside the outer curb of the roadways a distance equal to the depth of the encasement at the curb line. Where installed by open trench through unpaved areas, detector tape should be placed approximately one foot (1') above the encasement. Where a major route has a parallel outer roadway, encasement should be continuous under all roadways within the right of way.

Manholes or vent pipes are to be located at the right of way line or adjacent to the outer roadway.

For fiber optic cable, encasement should extend from within six feet (6') of one right of way line to within six feet (6') of the other right of way line.

Exceptions may be made for encasement as listed in [EPG 643.1.4.2](#).

### **643.1.3.2.4 Parallel Installations along Major Routes**

New parallel installations on the right of way may be permitted provided that poles are within two feet (2') of the normal right of way line and underground utility facilities are within the utility corridor. Existing overhead or underground utility facilities that parallel an existing roadway which will be incorporated into a completed highway may remain in place if all maintenance and service can be performed without entering or leaving the roadway except at approved access points; without parking equipment or storing materials on the median, pavement, ramps, or shoulders; and the existing location does not interfere with construction, maintenance, or operation of the completed highway. If an existing parallel utility facility needs to be relocated so as to not interfere with the construction, maintenance, or operation of the completed highway, poles may be located within five feet (5') of the right of way line.

Existing steel pipe transmission and distribution facilities for gaseous petroleum products that parallel an existing roadway that will be incorporated into the completed roadway may be left in place subject to an agreement by the utility owner that maintenance or service and facility expansion will be performed without cutting or damaging the pavement or interfering with the construction, maintenance, and operation of the highway and provided that the facility is cathodically protected against corrosion and meets the applicable material requirements.

Underground utility facilities are expected to be buried within the utility corridor of sight distance triangles (SDTs) at roadway intersections unless granted a variance. Overhead utility facilities may be allowed to span intersecting roadways with SDTs provided the poles, or supports, are located outside the SDT.

### **643.1.3.2.5 Sanitary Sewers within the Right of Way of Major Routes**

New installations of sanitary sewers should follow the applicable guidelines for either underground crossings or parallel installations as appropriate. An existing gravity trunk sanitary sewer should be considered individually and removed or left in place contingent upon its age, condition, feasibility of moving, and maintenance access. If an existing parallel gravity main is left in place within the limits of the paved surface, paved shoulder lines, or curb lines, stub mains as required will be laid between the sewer main and curb or shoulder lines for future service connections in each block. Manholes should be relocated outside the traveled roadway as near the right of way line as practical.

### **643.1.3.3 Minor Routes**

For structures carrying or over minor routes, see [EPG 643.1.5](#).

### **643.1.3.4.1 Utility Facilities Crossing Minor Routes**

#### *643.1.3.4.1.1 Overhead Crossings of Minor Routes*

Existing overhead crossings that interfere with construction, maintenance, or operation should be relocated with their supports as near the right of way line as is practical. New overhead crossing installations should be located with their supports as near the right of way line as is practical.

#### *643.1.3.4.1.2 Underground Crossings of Minor Routes*

All new utility facilities should be installed and maintained without cutting or damaging the pavement or paved shoulders. A variance may be granted for pavement cuts when servicing and maintaining the facility by any other methods is impractical. Pavement cuts may only be made by permits issued.

Underground crossings of utility facilities are to be continuously encased under the pavement, medians, ramps, and shoulders with the casing extending to the toe of the fill slopes or to the ditch line. In curbed sections, encasement should extend outside the outer curb of the roadway a distance equal to the depth of the encasement at the curb line. Where installed by open trench through unpaved areas, detector tape should be placed approximately one foot (1') above the encasement.

Manholes or vent pipes are to be located at the right of way line or adjacent to the outer roadway.

For fiber optic cable, encasement should extend from within six feet (6') of one right of way line to within six feet (6') of the other right of way line.

Exceptions may be made for encasement as listed in [EPG 643.1.4.2](#).

#### **643.1.3.4.2 Parallel Installations along Minor Routes**

New parallel installations on the right of way may be permitted provided that poles are within two feet (2') of the normal right of way line and underground utility facilities are within the utility corridor. Existing overhead or underground utility facilities that parallel an existing roadway which will be incorporated into a completed highway may remain in place if all maintenance and service can be performed without entering or leaving the roadway except at approved access points; without parking equipment or storing materials on the median, pavement, ramps, or shoulders; and the existing location does not interfere with construction, maintenance, or operation of the completed highway. If an existing parallel utility facility needs to be relocated so as to not interfere with the construction, maintenance, or operation of the completed highway, poles may be located within five feet (5') of the right of way line.

Underground utility facilities are expected to be buried within the utility corridor of sight distance triangles (SDTs) at roadway intersections unless granted a variance. Overhead utility facilities may be allowed to span intersecting roadways with SDTs provided the poles, or supports, are located outside the SDT.

#### **643.1.3.4.3 Sanitary Sewers within the Right of Way of Minor Routes**

New installations of sanitary sewers should follow the applicable guidelines for either underground crossings or parallel installations as appropriate. An existing gravity trunk sanitary sewer should be considered individually and removed or left in place contingent upon its age, condition, feasibility of moving, and maintenance access. If an existing parallel gravity main is left in place within the limits of the paved surface, paved shoulder lines, or curb lines, stub mains as required will be laid between the sewer main and curb or shoulder lines for future service connections in each block. Manholes should be relocated outside the traveled roadway.

#### **643.1.3.4 Roundabouts**

Regardless of roadway type, it is desirable to avoid locating utility facilities and their access points within the circulatory roadway. If possible, utility facilities are located in the legs of the roundabout to allow for future maintenance and access at an isolated leg versus affecting the entire roundabout.

#### **643.1.3.5 Utility Facilities in Scenic Enhancement Areas**

All existing utility facilities within the limits of a scenic enhancement area requiring adjustment because of construction or reconstruction will be placed underground or relocated beyond the limits of the scenic enhancement area. No new above ground facilities will be permitted. New underground facilities will be permitted provided they do not extensively alter or impair the appearance of the area.

## 643.1.4 Installation of Utility Facilities

---

The following sections provide information on the physical installation of utility facilities within highway right of way.

### 643.1.4.1 Minimum Cover for Underground Facilities

The minimum cover for new underground utilities is:

- Forty-two inches (42") for all water lines (parallel and crossings).
- Forty-two inches (42") for fiber optic cable (crossings encased in rigid conduit).
- Seventy-two inches (72") for fiber optic cable (crossings encased in polyethylene (PE) pipe).
- Thirty inches (30") for direct burial and in trench fiber optic cable (parallel).
- Twenty-four inches (24") for all other direct burial copper or coaxial cable, (parallel).
- Seventy-two inches (72") for uncased polyethylene (PE) gas pipe crossings under ditches and roadways but thirty inches (30") elsewhere.
- Thirty inches (30") for all other (such as, but not limited to, gravity sewers, forced sewers, and electric) underground utilities (both parallel and crossing).

### 643.1.4.2 Exceptions to Encasement

Exceptions may be made for encasement as follows:

- Non-fiber communication or electric cables installed in ducts.
- Welded steel pipelines carrying gaseous or liquid petroleum products - provided they are cathodically protected against corrosion, triple-coated in accordance with accepted pipeline construction standards, and meet applicable material requirements.
- Natural gas distribution pipe (nominal six-inch (6") diameter maximum) of polyethylene (PE) plastic, traceable, installed by a horizontal bore method at a minimum depth of seventy-two inches (72") under ditches and roadways, constructed in accordance with and meeting applicable material requirements.
- Gas service connections protected and constructed in accordance with and meeting applicable material requirements.
- Encasement is not required for new trunk sanitary sewer crossings of vitrified clay, reinforced concrete or cast iron except when installation procedures would produce voids in the roadbed, heavy fills, or installations under pressure.

### 643.1.4.3 Above Ground or Ground Level Appurtenances

Appurtenances protruding more than four inches (4") above the ground line should be located outside the clear zone. If no feasible alternative exists and if permitted by a variance, appurtenances may be allowed within the clear zone if they meet breakaway criteria or will be shielded by a traffic barrier. Good design practice will provide that appurtenances be located at right of way jogs, along intersecting road right of way, or at other similar acceptable locations, so that encroachment is held to an absolute minimum. Cables, wires, small diameter pipes, and other such utility appurtenances extending from the surface of the ground should be equipped with covers or guards to improve their visibility. Appurtenances within sidewalks or street level pedestrian access routes are to be in conformance with the Americans with Disabilities Act requirements.

The maximum pull box width perpendicular to the right of way line within the utility corridor is thirty inches (30").

### 643.1.4.4 Overhead Utility Facilities

The vertical clearance of new or existing overhead installations will not be less than the current minimum requirements of the National Electric Safety Code, but in no case less than eighteen feet (18') inclusive of sag above the groundline for electrical facilities. Clearance may be reduced for overhead installations of cable, telephone, or fiber optic facilities.

A minimum radial clearance of twenty-five feet (25') is provided from any utility facility to the nearest part of any bridge structure. A minimum radial clearance of ten feet (10') is provided from the nearest charged electrical line to a MoDOT signal, lighting, ITS, or overhead sign structure.

### 643.1.4.5 Approved Materials

Utility owners are allowed to use any material for underground utility facilities including carrier and encasement provided they accept responsibility for any future repairs and/or replacement of damaged MoDOT facilities should a failure occur. This will allow the use of current technology and procedures to provide the best value to its subscribers and the taxpayers of Missouri. For materials that MoDOT also uses in its highway system, utility owners must provide materials that meet the current [Missouri Standard Specifications for Highway Construction](#). For materials not listed in the Missouri Standard Specifications for Highway Construction, the utility owner should provide documentation of the standards used to determine suitability of the material.

### 643.1.4.6 Cutting

In the event permission is granted to cut an existing concrete or asphalt pavement or sidewalk, the appropriate provisions below should be followed.

#### 643.1.4.6.1 Pavement

All pavement cuts should be made with a saw to the full depth of the pavement. The width of the cut is typically determined by the width of the trench plus a minimum one foot (1') on each side of the trench. In the event the distance to any adjacent longitudinal or transverse joint or crack is less than four feet (4'), the pavement must be removed to the joint or crack. Cuts for perpendicular service ties should be a minimum of three feet (3') wide. Longitudinal main installations are typically cut at a minimum of half the lane width, but in no instance should the cut be along the wheel path of the lane.

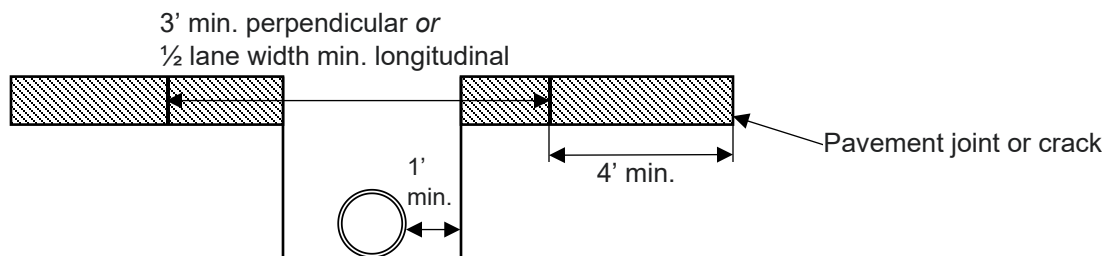

**EPG Figure 643.1.2. Pavement Repair Dimension Requirements.**

The utility facilities should be placed in a location with the least impact to the roadway. Typically, this leads to placement in the shoulder when available followed by the two-way left turn lane (TWLTL), and then outside lanes before allowing placement in interior through lanes. Lane switching should be kept to a minimum and should not be used to minimize repair sizes. Cuts for mains or service leads that may not be perpendicular to the roadway should be squared-off.

Replacement of cut pavement should be full depth concrete in accordance with the current version at the time of installation of Section 613.10 Full Depth Pavement Repairs of the Missouri Standard Specifications for Highway Construction and the Missouri Standard Plans for Highway Construction.

If the area of the pavement repair is not to be fully resurfaced all joints including the overcut from the sawing operation should be filled with an expansive mortar, epoxy, polyester, or joint material as approved by the Engineer in accordance with Section 1057 of the Missouri Standard Specifications for Highway Construction.

#### **643.1.4.6.2 Pedestrian Access Routes**

All cuts in the pedestrian access routes whether asphalt or concrete should be made by saw and be the full depth of the material. Entire slabs of concrete sidewalk should be removed. Repair of the pedestrian access route must meet Americans with Disability Act requirements, see [EPG 642](#). Cuts through curb ramps or detectable warning areas are not permitted. Rather the entire curb ramp or detectable warning area must be removed and replaced. MoDOT district ADA contacts can help ensure ADA compliance of impacted pedestrian access routes.

#### **643.1.4.7 Non-disturbance Areas**

MoDOT has certain areas of right of way where mowing, spraying, digging, or other vegetation disturbance activities are restricted. These areas have been established to mitigate the environmental impacts of a previous project and should be avoided. If the areas cannot be avoided, contact MoDOT's Environmental Section.

### **643.1.5 Bridge Attachment Policy**

---

No utility facility will be permitted in or on a structure carrying an interstate or other freeway unless it is part of a federal requirement or for MoDOT's use. When the structure carries any other road type and no other practical means exists for the crossing, wires (communication, electrical, fiber, or metal) will be permitted. Electrical lines must be located to cause minimum exposure to MoDOT maintenance personnel and the public. Pressurized pipelines for gas or other petroleum products and water and all sewer lines are prohibited on all structures due to the risks associated with their failure.

#### **643.1.5.1 Agreement**

An agreement is required for all utility facilities attached to any structure. A charge will be made for the increased maintenance costs involved. This fee is set by the Bridge Division. When permitted, a 50-year occupational agreement is executed with the utility owner. Agreement BR04 Utility Attachment Agreement is used when an attachment is added to a bridge during its construction. Agreement BR09 Bridge Attachment Agreement is used when an attachment is added to an existing bridge.

#### **643.1.5.2 Requests**

Requests to attach facilities to structures is a multi-step process. Bridge Division is responsible for approval of the bridge attachment. If at any point in the process, Bridge Division determines the attachment to be unacceptable, a reason is to be provided.

To start, the utility owner submits a conceptual request to the district utilities staff. The conceptual request consists of an explanation of the proposal; a general location sketch (i.e., which side of the bridge); and details on the facility, length, and weight per foot when full. The district utilities staff should work with all relevant district personnel including the District Bridge Engineer in reviewing and recommending the attachment. The district utilities staff will submit the recommended details to the Bridge Division to determine the applicable costs including future maintenance costs and for attachments to new bridges, design and construction. Once the Bridge Division has determined the cost, the district utilities staff shares the cost with the utility owner for their concurrence with furthering the process. For new bridges, if the utility owner concurs with the costs, the district utility

staff will prepare the BR04 Agreement for execution by the utility owner and the Commission. MoDOT will be responsible for the design and construction of attachments to new bridges. For existing bridges, the district utilities staff will forward the applicable as-built bridge plans to the utility owner for its use in designing the bridge attachment. The utility owner will provide detailed design drawings, signed and sealed by a professional engineer in the State of Missouri, to the district utilities staff for review. The district utilities staff should work with all relevant district personnel, including the District Bridge Engineer, in reviewing and recommending the details of the attachment to the Bridge Division. Once Bridge Division approves, the Bridge Division will prepare the BR09 Agreement for execution by the utility owner and the Commission. The utility owner is responsible for the construction of attachments to existing bridges. A [flow chart](#) of the process is available.

Payment from the utility owner for the attachment will be sent to Financial Services by district utilities staff. For BR04 agreements, district utilities staff should discuss with Financial Services how to get the payment credited to the project constructing the attachment. For BR09 agreements, district utilities staff should copy Bridge Division on correspondence with Financial Services. Checks should be made payable to Director of Revenue, Credit State Road Fund.

For requests from government entities such as cities, counties, and other municipalities, the requested information should be submitted to Bridge Division as described above. However, the district utilities staff will take the lead in preparing the DE10 County Agreement or DE11 Municipal Agreement, as applicable, with input from Bridge Division and Bridge Maintenance. All fees are waived for government entities.

### **643.1.5.3 Considerations**

The following considerations are made in determining the acceptability of a bridge attachment. Unique situations will be discussed with the Bridge Division as required.

#### **643.1.5.3.1 Bridge Asset Management Program**

Requests for bridge attachments should be reviewed for consistency with the district's upcoming bridge asset management program needs. If a structure is due for rehabilitation or replacement in the near future, information should be provided to the utility owner indicating existing remaining life of the bridge. In some instances, it may be in MoDOT's best interest to deny the request for attachment outright. In some instances, the utility owner may still choose to pursue the short-term attachment to the existing structure. In almost all cases, the utility owner is responsible for the cost of removing and/or relocating their utility facilities for a necessary repair, widening, improvement or reconstruction of the structure. Review existing agreements for cost responsibility for current attachments.

#### **643.1.5.3.2 Aesthetics**

In reviewing a request for a bridge attachment, how the structure is viewed by the public will be considered. For example, is the structure over a scenic stream that is extensively used by canoeists, or does the structure span a road that may provide access to a park, campgrounds, or boat launching facilities? Is the structure a grade separation where the motoring public will see the attachment before they pass under it?

#### **643.1.5.3.3 Method of Attachment**

In order to maintain structural integrity of any structures the following requirements will apply for attachments.

#### **643.1.5.3.3.1 Welding**

Welding of hardware to structural steel members (i.e., flanges, webs, stiffeners, and diaphragms) whether in tension or compression is not permitted.

#### **643.1.5.3.3.2 Drilling**

Drilling holes in any structural steel member is not permitted. Drilling holes for anchors into any prestressed concrete member is not permitted. Although permitted, drilling holes for anchors into the underside of bridge decks must be done with caution. It is recommended all anchors be installed to miss deck reinforcing steel. Generally, drilling into decks will not be allowed where sonotubes were used (voided slab bridges). The depth of the holes should be such that breaking out of the concrete on the top side of the deck does not occur.

#### **643.1.5.3.3.3 Corrosion**

Attachment hardware will be new, properly coated to prevent corrosion or be of a non-corrosive material, and be designed to support the facility.

### **643.1.5.3.4 Location**

In general, attachments are made on the underneath side of the bridge deck. The condition of the bridge deck will dictate the location of the attachment supports. An exception may be attachments to trusses or other overhead structures.

Attachments that may require manholes in bridge decks are not allowed.

When attachments are required to structures over streams that may carry large drifts, they must be attached to the downstream side of the structure and above the lowest superstructure element. It is preferred to locate the attachment on the outside of the exterior girder. If aesthetics are a concern, a better appearance can be achieved by having the attachment made to the inside of the exterior girder and above the bottom of the lower flange to hide the conduit and the attaching hardware.

Placement of utilities must not prevent the removal of old paint, the application of new paint on superstructure steel, or cause debris buildup, which could cause structural deterioration.

### **643.1.5.3.5 Construction and Maintenance**

If the attachment cannot be built while maintaining one (1) lane of traffic on the structure, it will not be allowed.

Construction procedures that severely impact traffic may factor into the allowable location of the attachment on the structure.

When scaffolding is to be attached or supported by bridge rails, bridge superstructure, or bridge substructure, the procedures for construction of the attachment must be reviewed.

The utility owner or local entity will pay for, or be responsible for, the painting of the attachment, if necessary, when the bridge requires painting.

## **643.1.6 Private Lines**

Private lines are permitted to cross the right of way of a highway in the same manner as outlined for all utility facilities in above sections of this article. Parallel installations along the right of way of a highway are not permitted. Special conditions at a specific location that make adherence to this policy impractical will be submitted to the Chief Engineer for consideration of an acceptable alternative. In certain situations, it may be necessary to obtain approval from the Federal Highway

Administration (FHWA) before approval to use the alternative can be given to the private utility owner.

## 643.1.7 Water and Sewer Separations

---

The Missouri Department of Natural Resources (MoDNR) Safe Drinking Water Commission via 10 CSR 60-10 and Clean Water Commission via 10 CSR 20-8 govern the design of water and sewer lines in the vicinity of one another. Basic criteria are outlined below for information, and details are contained within the regulations. MoDOT is not responsible for providing or acquiring adequate right of way for utility owners to comply with MoDNR requirements.

### 643.1.7.1 Water and Sewer Separations

#### 643.1.7.1.1 Horizontal

Sanitary and storm sewers are to be laid at least ten feet (10') horizontally measured from outside edge to outside edge from any existing or proposed water main. In cases where it is not practical to maintain ten feet (10') of separation, installation of the water main closer to the sewer is acceptable where the water main is installed in a separate trench or on an undisturbed earth shelf located on one (1) side of the sewer at an elevation so the bottom of the water main is at least eighteen inches (18") above the top of the sewer.

#### 643.1.7.2 Crossings

Water mains are to be laid to provide a minimum vertical distance of eighteen inches (18") vertically measured outside edge to edge from sanitary or storm sewers. This is the case whether the water main is above or below the sewer. One (1) full length of water pipe must be located so both joints will be as far from the sanitary or storm sewer line as possible. Special structural support for the water main or sanitary or sewer main may be required.

#### 643.1.7.3 Exceptions

When it is impossible to obtain proper horizontal and vertical separation as stipulated, the sewer will be designed and constructed equal to water pipe and will be pressure-tested to assure it is watertight prior to backfilling.

#### 643.1.7.2 Water Supply Interconnections

No physical connection is permitted between a public or private potable water supply system and any sanitary or storm sewer or appurtenance that would permit the passage of any sewage or polluted water into the water supply. No water pipe is permitted to pass through or come in contact with any part of a sanitary sewer manhole.

#### 643.1.7.3 Water Works Structures

Sewers are not permitted to be installed within fifty feet (50') in any direction from any existing or proposed public water supply well or other water supply sources or structures.

## 643.1.8 Variances

---

Occasionally, it is impractical to locate a utility facility in accordance with requirements outlined in this article. MoDOT may consider a utility owner's request for a variance from these requirements on a case-by-case basis. The utility owner should complete a [Utility Variance Approval Form](#) to be submitted to MoDOT for consideration. Variances on the Interstate System require approval of the Federal Highway Administration (FHWA). A [flow chart](#) of the variance process is available.

A variance will not be permitted just for the convenience of the utility owner. The utility owner requesting a variance must provide all necessary information to properly evaluate if a variance should be approved. For example, a utility owner requesting a variance because “the utility corridor is full” must explore all reasonable options. It is suggested that the requestor pothole the existing utility corridor to confirm the location of existing utility facilities and provide that data to support the need to locate outside of the utility corridor due to its congestion.

### **643.1.8.1 Variance Process**

Any utility owner of a public utility facility may apply for a variance. The process for requesting a variance is as follows:

#### **643.1.8.1.1 Submittal Requirements**

Utility owners submit to the district utilities staff a written request for a variance using the [Utility Variance Approval Form](#). The utility owner must clearly show the provision(s) or guideline(s) for which the variance is being requested; the condition(s) which the utility owner believes warrant(s) the granting of a variance; a thorough explanation of the reason(s) for the requested variance, including sufficient and appropriate documentation of safety, aesthetic, or constructability constraints that would be adverse to the function, access, or maintenance of the utility facility and not in the best interest of the public.

#### **643.1.8.1.2 MoDOT Consideration of Variance Request**

The utility owner bears full responsibility for demonstrating to MoDOT’s satisfaction that the variance is the most appropriate way to serve the public interest. MoDOT may present to the utility owner and the utility owner must consider reasonable alternatives to the variance requested by the utility owner. In determining whether to grant a variance, district utilities staff will consider all relevant factors including, but not limited to: the requested variance is reasonably necessary for the convenience, safety, health, and/or welfare of the public; there is an exceptional or undue burden or hardship on the specific applicant; a physical impracticability that would result from the applicant’s adherence to the normal location requirements; and the requested variance will not impair the safe construction, maintenance, operation, and safety of public travel on the highway. District utilities staff may consult with the Design Liaison Engineer in evaluating variances.

#### **643.1.8.1.3 Approval of Variances**

Once district utilities staff have agreed to accept a variance proposed by the utility owner, the [Utility Variance Approval Form](#) and all supporting documentation is sent to the District Design Engineer (DDE) for approval. If a variance is on interstate right of way, the DDE-signed Variance Request Form and all supporting documentation is forwarded to the Design Liaison Engineer who will forward to FHWA for their concurrence.

#### **643.1.8.1.4 Variance Appeal Informal Hearing**

If denied a variance, the utility owner has thirty (30) calendar days to request an informal hearing for the purpose of appealing the denial. Requests must be made in writing to the State Design Engineer, Missouri Department of Transportation, P.O. Box 270, Jefferson City, MO 65102. If the utility owner requests an informal hearing, MoDOT’s authorized representative will advise the applicant of the time, date, and place of the hearing. The hearing is not a contested case under RSMo 536. The rules of evidence will not apply at the hearing, and MoDOT’s decision after the conduct of the hearing is not subject to further appeal.

## 643.1.9 Excess Right of Way

---

Prior to conveyance of excess right of way, the status of utility facilities within said parcel must be addressed. See [EPG 236.5.12](#).

## 643.1.10 Broadband

---

Broadband development in the state of Missouri is handled by the Department of Economic Development (DED). MoDOT shares its approved Statewide Transportation Improvement Program (STIP) project list with DED. All MoDOT policies related to placement of utility facilities within Commission right of way as outlined in this EPG article 643.1 are to be followed.

# 643.2 Utilities in Program Delivery

## 643.2.1 Introduction

---

Improvements to the highway system often require negotiation between the Commission and a city, a county, or a public or private utility owner. The Commission's district utilities staff is responsible for coordination of highway improvement projects with the utility owner's representative. The impact to a utility, the responsibility for the cost of adjustments necessary to allow highway construction, the plan of adjustment of the utility, the responsibility of performance of work on utility facilities, and the schedule of the utility adjustment are all items that vary depending on the project and should be investigated and negotiated to ensure highway improvement projects are delivered on-time and on-budget. These should comply with Commission policy. A [flowchart](#) outlining all the utility adjustment processes (reimbursable and non-reimbursable relocations, Master Reimbursable Utility Agreements and Project Specific Agreements, etc.) are available in the list of figures at the top of the page. These processes will not always be in combination, but each should be considered with each project.

The district utilities staff, in conjunction with the Transportation Project Manager (TPM), is expected to invite and encourage participation of utility owner representatives in MoDOT project meetings as needed.

When a project involves utility adjustments for which the Commission is responsible for costs, the TPM should program the costs of the utility adjustments as non-contractual construction costs in the STIP Information Management System (SIMS).

## 643.2.2 Annual Utility Meeting

---

Each district should hold an annual meeting with utilities to discuss current STIP projects in the district. The annual meeting should be held during each year's STIP preparations, ideally between January and May. All utility owners that have utility facilities in the district should be invited. The intent is to provide the utility owners with an idea of upcoming projects to allow them the opportunity to plan and budget for potential adjustments of their utility facilities, identify both MoDOT and utility roadblocks, and develop action plans to complete utility adjustments better, faster, and cheaper.

## 643.2.3 Determination of Existing Utilities

---

District utilities staff should determine the appropriate level of effort needed to accurately identify existing utilities within the footprint of a proposed highway construction project. Aboveground utilities are easily identifiable via field checks; however, determination of the precise location of underground

utilities can be more challenging and time consuming. Therefore, the district utilities staff should balance the risk of conflict with the highway construction project against the level of effort needed to determine the location.

The level of effort on mapping utilities is dependent on the scope of the project and the potential for utilities having an impact on the construction of the project. The project schedule should include the time to complete this task accurately. The time and effort necessary for having accurate locates requires close interaction with the utility locators. Early contact with utility owner representatives may be necessary to accurately locate underground utility facilities.

Various methods of determining existing underground utilities result in different levels of quality. ASCE Standard 38 Standard Guidance for Investigating and Documenting Existing Utilities classifies four levels of quality:

1. Quality Level D: QL-D is the most basic level of information for utility locations. It comes solely from existing utility records or verbal recollections, both typically unreliable sources. It may provide an overall "feel" for the congestion of utilities but is often highly limited in terms of comprehensiveness and accuracy. QL-D is useful primarily for project planning and route selection activities.
  - o Missouri 811 or "private-locate" markings are to be considered to be QL-D.
2. Quality Level C: QL-C is probably the most used level of information. It involves surveying visible utility facilities (e.g., manholes, valve boxes, etc.) and correlating this information with existing utility records (QL-D information). When using this information, it is not unusual to find that many underground utilities have been either omitted or erroneously plotted. Therefore, its usefulness is primarily on rural projects where utilities are not prevalent or are not too expensive to repair or relocate.
3. Quality Level B: QL-B involves the application of appropriate surface geophysical methods to determine the existence and horizontal position of virtually all utilities within the project limits. This activity is called "designating". The information obtained in this manner is surveyed to project control. It addresses problems caused by inaccurate utility records, abandoned or unrecorded utility facilities, and lost references. The proper selection and application of surface geophysical techniques for achieving QL-B data is critical. Information provided by QL-B can enable the accomplishment of preliminary engineering goals. Decisions regarding location of storm drainage systems, footers, foundations, and other design features can be made to avoid conflicts with existing utilities. Slight adjustments in design can produce substantial cost savings by eliminating utility relocations.
4. Quality Level A: QL-A, also known as "locating or potholing", is the highest level of accuracy presently available and involves the full use of the subsurface utility engineering services. It provides information for the precise plan and profile mapping of underground utilities through the nondestructive exposure of underground utilities, and provides the type, size, condition, material, and other characteristics of underground features.

For projects with scopes that have potential for utility conflicts, the minimum level of effort required is SUE Quality Level D. Locations of existing utilities are determined by requesting locates through Missouri 811, also known as the "One-Call" process. Missouri 811 locating requests should be carefully considered for the scope of work of the project. When necessary, the location of existing utilities should be established by a field survey of locate markings and features and shown on the roadway plans. Higher level SUE Quality Levels can be used on any project. Adjustment cost savings, whether to the MoDOT or to the utility owner, are beneficial to the taxpayer. Good SUE projects are typically urban in nature, or in congested areas, where the project footprint is to be

minimized, or anytime accurate vertical and horizontal location of the utility facility might allow a design to avoid the utility facility thus preventing the need for the adjustment. The SUE process combines civil engineering, surveying, and geophysics. It utilizes several technologies, including vacuum excavation and surface geophysics.

When proposed excavation or installation of subsurface features (drainage, equipment bases, etc.) falls within three feet (3') of a marked Missouri 811 line, soft digging (hand digging, potholing, vacuum methods, pressurized air/water jetting, pneumatic hand tools, etc.) is required to more exactly locate the utility facility both horizontally and vertically. Utility facilities present within the right of way by permit, should be investigated by the utility owner. Utility facilities that would be reimbursable or partially reimbursable as defined in EP 643.2.8 will be investigated by MoDOT.

## 643.2.4 Conflict Determination

---

Determination of whether a conflict exists between an existing utility facility and a proposed highway improvement project should occur at the earliest possible stage of project development. A conflict may be the result of the physical interaction between the roadway infrastructure and utility facility, a reduction in cover or increase in fill over underground utilities, a reduction in horizontal clearance whether above or below ground, a reduction in overhead vertical clearance, paving over utilities, or restricting a utility owner's access to its utility facilities. District utilities staff should work with utilities to determine if a conflict exists and the appropriate plan of adjustment to remedy the conflict. The adjustment to the utility may be a relocation or another measure that protects the utility or access to the utility from the proposed highway improvement project. Determination of a conflict needs to be continually re-evaluated as the project design progresses. Continuing coordination is essential.

## 643.2.5 Utility Plan of Adjustment

---

### 643.2.5.1 Request for Plan of Adjustment

District utilities staff will request a plan of adjustment from utility owners whose utility facilities are in conflict with a proposed highway project. The plan of adjustment may consist of efforts to relocate the utility or otherwise protect a utility from the impacts of the proposed highway project. Utilities are shown on the roadway plan and profiles sheets that are furnished to utility owners for use in planning required utility adjustments. Any other sheets such as drainage, traffic signal, lighting, or ITS plans that show impacts to a utility facility should also be provided to the utility owners. All adjustments, reimbursable or not, require a plan of adjustment furnished by the utility owner.

A transmittal letter is included in the request for a plan of adjustment. The letter informs the utility owner that regardless of whether an adjustment is reimbursable, no physical adjusting or relocating of their utility facilities to accommodate the proposed highway improvement is to be performed without specific approval and authorization. Additionally, if any part of the adjustment has the potential to be reimbursable, they are advised:

1. They may undertake preliminary engineering by their own forces upon approval by district utilities staff of the estimated costs of preliminary engineering.
2. They may employ a consultant to do the PE work provided they request and obtain prior approval. See [EPG 643.2.6 Preliminary Engineering Requirements](#).
3. Any preliminary engineering costs accrued prior to the date of written authorization to proceed will not qualify for reimbursement.
4. Replacement right of way or easements cannot be purchased without specific approval and authorization.

### 643.2.5.2 Proposed Plan of Adjustment

Developing a plan of adjustment is a multi-step process. The utility owner will propose a conceptual approach to adjusting the utility facilities to allow highway construction. This conceptual approach is used as the basis for determining cost responsibility, estimate of costs for preliminary engineering and construction, developing the agreement if necessary, and final design of the adjustment. Negotiations between district utility staff and the utility owner's representative can result in changes to the design throughout the process.

Final plans of adjustment must contain a legend on the first sheet identifying the utility symbols used. They must also show the existing utility facilities and their disposition, the location of the new or adjusted utility facilities, the existing and new right of way lines, the limited or fully controlled access symbols (where applicable), the existing and proposed roadways, ramps, and outer roadways and any other pertinent roadway information. They must contain sufficient details concerning location, elevation, compaction, clean up, etc. to provide for the proper adjustment of the utility facility. Relocated and/or existing utility facilities that will remain in place must be dimensioned or indicated in a manner to show their location in respect to the right of way lines. It is preferred that the utility owner transmits the plan of adjustment by electronic deliverables in a format that can be incorporated into the roadway plans. This will reduce the time and effort necessary as well as increase the accuracy of transferring this information into the roadway plans.

Plans of adjustment received from the utility owner are to be checked for compliance with MoDOT's requirements ([EPG 643.1 Utility Location](#)) by the district utilities staff. They are also checked to ensure compatibility with the roadway design. Any continuing conflicts are resolved through negotiations with the utility owner.

Occasionally, it is impractical to perform a utility adjustment in accordance with MoDOT's requirements. Sometimes the utility may request approval of a plan of adjustment that does not conform to these requirements. Deviation from MoDOT's utility requirements is a variance. Refer to [643.1.8 Variance Process](#) for additional guidance.

The final plan of adjustment is included as Exhibit "A" to the agreement ([EPG 643.2.12 Agreements](#)).

## 643.2.6 Preliminary Engineering Requirements

---

Preliminary engineering (PE) can be performed one of four ways for utility adjustments:

1. The utility owner can use its own engineering forces.
2. MoDOT can select an engineering consultant, after consultation with the utility owner, and the consultant contract will be administered by MoDOT.
3. The utility owner can select an engineering consultant, with approval by MoDOT, and the consultant contract will be administered by the utility owner.
4. If a utility adjustment is being included in a MoDOT administered construction contract, the preliminary engineering of the adjustment can be provided by MoDOT.

For reimbursable utility adjustments, the amount paid to engineers, architects, and others for required engineering and allied services can be included in reimbursement amount provided such amounts are not based on a percentage of the costs of the necessary adjustments to allow highway construction. Reimbursement is available for contracts executed after solicitation of a consultant for the specific adjustment or existing continuing contracts when it is demonstrated that such work is performed regularly for the utility owner in its own work and that the costs are reasonable.

A [checklist](#) is available for reviewing consultant-engineering contracts to ensure the contract conforms to MoDOT policy and complies with applicable federal regulations. District utilities staff should use the checklist to review contracts and may consult with Audits and Investigations Division as necessary. The procedures in 23 CFR part 172, Administration of Engineering and Design Related Service Contracts may be used as a guide for reviewing proposed consultant contracts. [EPG 136.4 Consultant Selection and Consultant Contract Management](#) may also be used as a guide.

### **643.2.6.1 Solicited Consultant Contracts**

If solicitation of PE services is required for reimbursable utility adjustments, the utility owner must provide the following documents and information to district utilities staff. These documents need to be provided as soon as the utility owner has chosen to solicit a consultant. Document 1 must be supplied by all utility owners. Documents 2 and 3 are only required when the utility owner is a local government agency who is also a political subdivision of the state of Missouri (e.g., city-owned utilities, county-owned utilities). All other utility owners are encouraged, but not required, to provide Documents 2 and 3:

1. A statement that the utility owner is not staffed or able to perform the required PE services with its own forces.
2. Provide the names of at least three (3) consultants considered.
3. The criteria used to evaluate each consultant and reasons why the selected consultant was selected.

The following documents need to be provided as soon as the utility owner has successfully negotiated and entered into a contract with the consultant:

1. The name and address of the selected consultant.
2. A statement that the "[Certification of Consultant](#)" will be furnished immediately upon award of the contract to the consultant.
3. One executed copy of the proposed engineering contract or agreement between the utility owner and consultant, only if the engineering will exceed \$5,000.00.
4. The consultant's fixed (lump sum) or estimated fee (actual cost) and the contract maximum.
5. A cost summary providing a detailed breakdown of the basis for the consultant's compensation, including estimated labor hours, hourly rates for each classification, overhead rate (if used), the amount of profit charged, and any other estimated charges such as travel expenses, equipment rentals, etc. If an overhead rate is used, the consultant must also submit the supporting overhead rate calculations.
6. An independent cost estimate of engineering services provided by the utility owner to use in comparison to the consultant's proposed engineering services to check for cost reasonableness.

### **643.2.6.2 Continuing Consultant Contracts**

When a utility owner chooses to use an existing continuing contract for PE services, the utility owner must provide the following documents and information to the district utilities staff as soon as possible.

1. A statement that the utility owner is not staffed or able to perform the engineering with its own forces.
2. The name and address of the consultant under the existing continuing contract.
3. A statement that the "[Certification of Consultant](#)" will be furnished.

4. A copy of the continuing contract to the district utilities staff. The district utilities staff will review the contract for reasonableness of cost.
5. The consultant's fixed (lump sum) or estimated fee (actual cost) and the contract maximum for the work associated with the utility adjustment.
6. A cost summary providing a detailed breakdown of the basis for the consultant's compensation, including estimated labor hours, hourly rates for each classification, overhead rate (if used), the amount of profit charged, and any other estimated charges such as travel expenses, telephone, etc. If an overhead rate is used, the consultant must also submit the supporting overhead rate calculations.
7. An independent cost estimate of engineering services provided by the utility owner to use in comparison to the consultant's proposed engineering services to check for cost reasonableness.

### **643.2.6.3 Consultant Contract Changes**

If a PE services contract between a utility owner and a consultant needs to be revised, a copy of the revised contract, fee, and schedule should be submitted by the utility owner to the district utilities staff prior to allowing for contract changes. District utilities staff should review the contract changes to ensure the revised contract conforms to MoDOT policy and complies with applicable federal regulations.

## **643.2.7 Environmental and Right of Way**

---

### **643.2.7.1 Utilities and Environmental Clearances**

District utilities staff should coordinate with the TPM and utility owner's representative to understand and communicate on known environmental and cultural constraints that could impact a utility owner's plan of adjustment. This will allow the utility owner to consider permitting timelines and alternatives that avoid environmental or cultural resources to keep the project on schedule.

One strategy to make project delivery more efficient and ensure regulatory compliance is for MoDOT to obtain the environmental and cultural resource permits and clearances for the utility owners associated with a roadway improvement while obtaining its own. This would generally only be for the permits and regulatory clearances MoDOT already needs to pursue as a part of the transportation improvement.

District utilities staff should coordinate with the utility owner's representative early in the project timeline to determine if it is in the best interest of both MoDOT and the utility owner to obtain permits and environmental clearances jointly. The following strategies can be utilized to determine if a joint approach to environmental work should be pursued:

- If utility facilities are moving to a location within or immediately adjacent to MoDOT right of way, a utility owner may be invited to participate in permitting and environmental compliance activities.
- If utilities move to a location not within or adjacent to MoDOT right of way, the utility company would not normally be invited to participate in permit applications and environmental compliance activities. However, some unique projects may necessitate further attention and should be discussed with the Design Liaison Engineer.

If MoDOT and the utility owner agree to obtain joint permits and clearances, written communication between the utility owner's representative and the district utilities staff should document the following items:

- List of the permits and clearances that MoDOT will acquire on behalf of the utility owner.
- List of the information needed from the utility owner in order for MoDOT to acquire the permits and clearances.
- Schedule and deadlines for submittal of the information by the utility owner. For example: utility plans, fill quantities, construction methods, dates, or seasons of construction.

Permits and clearances that may be needed by both a utility owner and MoDOT include:

- [Endangered Species Act consultation and clearance](#)
- [Section 106 of the National Historic Preservation Act clearance](#)
- [Section 4\(f\) clearance](#)
- [Section 6\(f\) of the Land and Water Conservation Fund Act clearance](#)
- [Section 401 and Section 404 of the Clean Water Act permits](#)
- [Section 402 of the Clean Water Act permit \(State Operating Permit for Erosion Control\)](#)
- [Recommendations on contaminated soil disposition](#)

### **643.2.7.2 Right of Way Acquisition and Utilities**

The Commission is obligated to acquire the width of right of way required by the design of the highway improvement. For utility facilities currently located within the Commission's right of way, this includes the necessary space for the utility facilities impacted by the design of the highway improvement. Either additional right of way width to accommodate a utility corridor or a utility easement can be obtained for the relocation of utility facilities. When drainage easements are acquired along a channel, additional space for utility facilities should be considered to avoid conflicts between the utility facility and the bridge or culvert.

District utilities staff should inform the utility owner's representative of the potential of a conflict between an existing utility facility and a proposed highway construction project early in the project development process to allow sufficient time for the utility owner to prepare a plan of adjustment and notify the district utilities staff of any easement needs. When utility facilities are located on a utility owner's private easement, the utility owner may obtain its own new easements. If the utility owner is not in a position to negotiate for new easements or if the utility owner's policies will not permit it to condemn property to obtain the easement, MoDOT can acquire the easement in the same manner roadway right of way is obtained. The district utilities staff should verify the utility owner is aware of the opportunity to have MoDOT acquire the easement, and the utility owner should provide written documentation on whether the utility owner would like to pursue this option with MoDOT.

For situations where the utility owner will obtain its own replacement right of way and the cost of the adjustment is MoDOT's responsibility, the utility right of way cost should be reviewed by the district right of way department to ensure the cost is reasonable and acquisition followed state and federal regulations. In order to expedite utility adjustments necessary to allow highway construction, the district utility staff may authorize the utility owner to obtain easements prior to all details of a plan of adjustment being developed. In this situation, the district utilities staff should ensure enough details are known to justify the needed right of way, and an agreement for right of way costs only should be executed with the utility owner.

For situations where MoDOT will obtain the right of way necessary to allow highway construction, district utility staff should negotiate with the utility owner's representative to ensure all necessary utility easements are shown on the approved right of way plans. The TPM should confirm with district utilities staff that the right of way plans accurately reflect the needs of the utility owners prior to requesting right of way plan approval. The district Right of Way Manager should confirm with

district utilities staff before requesting an acquisition date (A-date). Every effort should be made to avoid adding utility easement requests once negotiations with property owners have begun.

Occasionally, when negotiations cannot be completed for easements for the adjustment of utility facilities, it may be necessary to condemn for the property. District utilities staff should coordinate with the utility owner's representative to ensure no alternate design for the adjustment of the utility facility is practical. The decision to condemn for easements for the adjustment of the utility facilities requires the exercise of good judgment in reaching the conclusion that further good faith negotiations are futile and condemnation is necessary to maintain the project in the scheduled letting. The TPM should coordinate with the district utilities staff and district Right of Way (RW) personnel on the condemnation proceedings.

Easement and other right of way documents used with utility owners are handled in accordance with procedures established jointly with RW and district utilities staff. District survey staff prepare the land descriptions for use in utility easements. The district utilities staff is responsible for completion of the easements in the correct form and scope. A sketch delineating the area described is attached to the easement as Exhibit "A". Communication with the Design Division will ensure use of proper forms, corporate names and locations, and particular wording required for joint ownerships. The description for a utility easement is to be referenced to the nearest land corner shown on the plans. Examples of easements can be found in the template list in [eAgreements](#).

In situations where MoDOT is acquiring right of way with existing utility easements, but the district utilities staff and the utility owner's representative agree that the utility facility may remain in place, the utility owner will release the property to the Commission separate from the right of way acquisition. This is done by executing an Easement for Highway Construction (UT16). The utility owner grants and conveys, with warranty of title expressed or implied, to the Commission, the right to construct, reconstruct, and maintain a highway over and across that portion of the easement owned and held by the utility owner. In the future, the utility owner retains any reimbursable rights should future projects require adjustments to allow highway construction.

## 643.2.8 Cost Responsibility

---

In addition to determining if a conflict exists between an existing utility facility and a highway improvement project, it is important to determine who is responsible for the costs of the necessary adjustments to allow highway construction. An adjustment for which the Commission is responsible for the costs is known as a reimbursable adjustment. An adjustment for which the Commission is not responsible for the costs is known as a non-reimbursable adjustment. An adjustment for which the Commission and the utility share responsibility for costs is known as a partially reimbursable adjustment. Adjustments determined to be reimbursable or partially reimbursable by the Commission are to be completed under the terms of an agreement executed between the utility owner and the Commission.

### 643.2.8.1 Commission Responsibility

#### 643.2.8.1.1 Utility Facilities Located on Private Easements

When the utility facility is located on a private easement within the new right of way to be acquired for a future project, the Commission is responsible for the cost of the necessary adjustments to allow highway construction. It may be possible that such easement does not have written easement rights. The Commission will honor this oral right provided acceptable documentation is provided by the utility owner to the district utilities staff. [An example](#) of acceptable documentation for not written easement rights is available. Other forms of documentation will be considered on an individual basis.

#### **643.2.8.1.1.1 Future Moves**

When the utility facility is located on a private easement, taken into the Commission's right of way, the Commission may agree that any future moves of the same utility by Commission order may be made at the Commission's cost. Documentation of this agreement is by an Easement for Highway Construction (UT16) agreement. If the Commission provides a substitute private easement, then the Commission will have future obligations consistent with the utility facility's status in an easement.

#### **643.2.8.1.2 Utility Facilities Located within Commission Right of way**

When the utility facility is located within Commission right of way, but has prior land rights, the Commission is responsible for the cost of adjustments to allow highway construction. The utility owner is responsible for documenting to the satisfaction of the district utilities staff, the basis for the claim of prior land rights within Commission right of way. Time spent researching prior rights is considered coordination and is reimbursable.

#### **643.2.8.1.3 City or County Utility Facilities on City or County Streets**

When roadway improvements are within the corporate limits of cities, towns, and villages, a municipal agreement is negotiated between the Commission and the municipality. Likewise, when roadway improvements are within the limits of a county and outside the municipal limits, a county agreement is negotiated between the Commission and the County Commission. Included in these agreements are provisions regarding reimbursement for adjusting city or county owned utility facilities. Reimbursement is provided for adjustment of city or county owned utility facilities that are now located on city or county streets and not on Commission right of way.

#### **643.2.8.1.4 Lumen**

Lumen – National (formerly CenturyLink, Lightcore, or Digital Telephone, Inc. (DTI)) and the Commission have entered into a partnership agreement, "Amended and Restated Fiber Optic Cable on Freeways in Missouri," executed June 5, 2003 which obligates the Commission to be responsible for the cost of the necessary adjustments to allow highway construction along the routes identified in the agreement. A copy of the agreement is available to district utilities staff.

#### **643.2.8.1.5 Services to the Commission**

When a utility facility provides a service connection to local Commission facilities such as power to traffic signals, lighting, ITS, and cathodic protection and phone drops to traffic signal controllers or other Commission facilities, the Commission is responsible for the cost of the necessary adjustments to allow highway construction.

#### **643.2.8.1.6 Private Service Lines**

While most utility owners reconnect the private service lines at no cost to the property owner, some do not. If a utility owner does not reconnect service lines, MoDOT can include adjustment of private service lines in roadway contracts. Bid items for relocating service connections are provided for the different types of anticipated adjustments.

#### **643.2.8.1.7 Second Moves**

If the Commission requires additional work to a utility facility after the facility has been relocated or adjusted in accordance with a plan of adjustment approved by the Commission for a single project number, the Commission is responsible for the cost of the additional work regardless of whether the initial adjustment was Commission responsibility as outlined in other parts of [643.2.8.1](#).

The purpose of the policy is to encourage utilities to relocate early rather than waiting until plans are published for bidding. The policy eliminates the utility having to relocate twice at its own expense because of late changes in the design. It is best to have utilities relocated prior to construction, and this policy helps achieve that goal. Therefore, it is imperative that the designer notifies district utilities staff as soon as possible of any changes made after these plans have been sent. If notified immediately, it may be possible to inform the utility owner prior to their final design thereby eliminating a second move.

Under this policy, the following are not considered second moves. Temporary and staged relocations necessary to accommodate construction and agreed upon by the utility and the Commission prior to relocation are considered a single move and are not subject to the provisions of the second move policy. If the Commission requires adjustment of a utility facility for which the utility owner is responsible for the cost of the adjustment and was originally determined to not need adjustment, the utility owner is responsible for the cost of the adjustment. The utility owner is responsible for the cost of additional work to any portion of the utility facility after the utility facility has been adjusted in accordance with a plan of adjustment approved by the Commission if the additional work is required by the Commission due to error by the utility owner in preparation of plan of adjustment, field location of, or construction of the adjustment of the utility facility.

When evaluating construction contract changes by change order or value engineering, the impacts of the second move policy should be considered.

## **643.2.8.2 Utility Owner Responsibility**

### **643.2.8.2.1 Utility Facilities Owned and Operated by a Political Subdivision**

When a utility facility is located within Commission right of way, but does not have prior land rights, the utility owner is responsible for the cost of the necessary adjustments to allow highway construction. When a utility facility is located on public right of way other than Commission right of way, the utility owner is responsible for the cost of the necessary adjustments to allow highway construction.

When a political subdivision must bear part or all the cost of adjustments to their utility facilities, and the cost creates a financial hardship, the Commission, by its authorized representative, the Chief Engineer, may temporarily assume these costs. A payback agreement with the political subdivision will include an applicable interest rate for a comparable maturity from a widely published index of tax-exempt municipal rates obtained from Financial Services. Payback time will not exceed five (5) years.

### **643.2.8.2.2 Utility Facilities Other Than Those Owned by a Political Subdivision**

When a utility facility is on the right of way of a public road or street or on state highway right of way without prior land rights and adjustment is necessary to allow for the construction of a roadway improvement, the utility owner is responsible for the cost of the necessary adjustments to allow highway construction.

### **643.2.8.3 Shared Responsibility**

When a utility facility is located such that portions of it are a Commission responsibility and portions of it are a utility owner responsibility by the definitions above, the costs of the necessary adjustments to allow highway construction will be split by the Commission and the utility owner. If the exact cost for each party can be determined, each party will be responsible for their portion of the cost of

relocating the utility facility. If the exact cost for each party cannot be determined, the parties will arrive at a percentage reimbursement on an equitable basis.

#### **643.2.8.4 Notice of Hearing**

When relocation or other difficulties with utility facilities on public right of way arise that prevent resolution by negotiation, formal hearings will be required.

The district initiates a request for a utility relocation hearing with a letter to the Chief Counsel's Office (CCO) (a copy is provided to the Design Division) requesting a hearing date. CCO will arrange for a hearing room, court reporter, etc. and advise the district of the hearing date.

The district will prepare the notice of hearing by strictly following the given format and serve the notice on all persons and utility owners listed. The property and utility owner must be served only by personal service or by mailing a certified letter, return receipt requested, no later than 15 days before the date of hearing. This will require the district to make every effort to identify the correct property owner before preparing the notice of hearing. To avoid delays, every attempt will be made to issue the hearing notice at least 30 days prior to the hearing date in case any property has changed ownership and any additional property owners must be served. A notice of hearing on service line connections will also be served on the private or public owner of the main or distribution line to which the service lines are connected. A notarized "Report of Personal Service" will be completed when notification by certified mail is not used.

One copy of the hearing notice and attachments, "Report of Personal Service" and certified mail notices are to be submitted to CCO after notification is complete.

Prior to the hearing, the district's representative will become familiar with the details of the utility adjustment in order to provide concise testimony to expedite the hearing process. CCO will assign an attorney to work with the district and present the case.

Refer to 7 CSR 10-3.030 020 Utility Relocation Hearings for additional information.

A Waiver of Hearing should be obtained for non-reimbursable adjustments to document the commitment of the utility owner to adjust its utility facilities without adversely impacting the highway construction project. This may be accomplished informally via written communications between the district utilities staff and the utility owner's representative. A formal **Waiver of Hearing** statement may be requested by either MoDOT or the utility owner. A **sample transmittal letter** for the Waiver of Hearing is available. For reimbursable or partially reimbursable adjustments, the formal agreement serves as the basis of documentation of this commitment.

### **643.2.9 Estimates**

---

District utilities staff will negotiate with utility owners to determine reimbursable costs of the necessary adjustments to allow highway construction (**EPG 643.2.8 Cost Responsibility**). These estimates are prepared in accordance with the provisions of 23 CFR 645 and any amendment thereto. These estimates must reflect the same procedures and costs used by the utility owners in their normal operations and must also accurately represent the expected costs of the work. The utility owner's estimate will be reviewed by the district utilities staff to ensure compliance with 23 CFR 645.

#### **643.2.9.1 Independent Cost Estimate**

The independent cost estimate provides the basis for district utilities staff to review the utility owner's estimate of costs of the necessary utility adjustments to allow highway construction and any

subsequent negotiations with the utility owner. The district utilities staff should prepare an independent cost estimate. The independent cost estimate may be based on unit prices of anticipated items of work in a utility adjustment necessary to allow highway construction. The independent cost estimate alternately may be based on recent similar types of utility adjustments necessary to allow highway construction and scaled for size. Consultants can be used to develop the independent cost estimate. All documentation of the independent cost estimate should be placed in MoProjects.

### **643.2.9.2 Type of Project Cost Estimates**

Either Actual Cost or Lump Sum estimates may be used for estimating the costs on the necessary utility adjustments to allow highway construction. If an Actual Cost estimate is used, detailed records of materials, labor, and equipment are made by district utilities and/or construction staff during construction, and a final audit of the utility owner's cost records is made to determine the Commission's actual responsibility for costs of the adjustment completed to allow highway construction. If a Lump Sum estimate is used, a final audit of costs for an adjustment in payment is not required. The Actual Cost method requires more detailed record keeping and documentation by the utility owner and district staff during construction. The Lump Sum method requires more upfront detail and work by the utility owner and judgment on the district utilities staff on the acceptability of the cost. The district utilities staff will work with the utility owner's representative to determine the best type of estimate and therefore agreement to use.

#### **643.2.9.2.1 Actual Cost Estimate**

The cost estimate that supports the actual cost agreement is prepared in sufficient detail to determine the reasonable expected cost of the work to support development of an agreement between the utility owner and the Commission. However, reimbursement is based on the actual costs of design and construction of the necessary adjustment to allow highway construction. The actual cost estimate should detail all costs of the necessary adjustment to allow highway construction, even if the Commission is only responsible for a portion of the costs as detailed in [EPG 643.2.8.3 Shared Responsibility](#).

Actual cost estimates can be used for any dollar amount of reimbursement.

#### **643.2.9.2.2 Lump Sum Estimates**

The cost estimate that supports the lump sum agreement must be accurate, comprehensive, verifiable, and in sufficient detail to present a clear picture of the work involved and the cost of the individual items. The estimate may cover only that portion of the adjustment for which the Commission is responsible for the costs of the necessary utility adjustments to allow highway construction.

Lump sum estimates are limited to a maximum of \$200,000 of Commission responsibility of costs of the necessary utility adjustments to allow highway construction; however, exceptions may be made for special situations that have prior approval from Design Division. These exceptions usually cover major relocations for which the Commission's proportionate responsibility is extremely small.

### **643.2.9.3 Utility Cost Estimate Requirements**

Whether using an Actual Cost or Lump Sum estimate, the following should be included in the estimate, if applicable. If any of the following sections are not included in the estimate, a qualifying statement as to why the costs were not included should be provided.

#### **643.2.9.3.1 Scope of Work**

All estimates require a concise summary of the work to be performed on the estimate. An example is "an estimate of cost covering the work of relocating Company's 12-inch Cushing-Woodriver pipeline to accommodate construction of Route 47 in Franklin County on Job No. J6P0172".

### **643.2.9.3.2 Engineering Costs**

Costs of engineering, whether preliminary or construction, must be shown as separate items and are not to be included with "labor costs". Concurrent cost accounting procedures of FHWA and MoDOT make this a necessity. See [EPG 643.2.6 Preliminary Engineering](#) and [EPG 643.2.16.2 Construction Contract Requirements](#) for further information.

### **643.2.9.3.3 Right of Way Costs**

A detailed estimate of the cost to acquire replacement easements by the utility owner is required. The cost should be supported by a right of way plan.

### **643.2.9.3.4 Material Costs**

Quantities, description of the item, the unit cost, and the extended totals are shown. Percentage computations will be shown immediately following "total cost" so the utility owner's and Commission's cost obligations are properly indicated. Unit assembly costs similar to those used by several of the rural electric association (R.E.A.) cooperatives are acceptable, provided the same units and charges are used in the utility owner's regular operations. A handling charge conforming with the utility owner's regular procedures may also be included.

### **643.2.9.3.5 Labor Costs**

Hours, individual or crew rates, and extended totals are shown. Payroll additives such as insurance, retirement, social security, vacation, and other benefits are shown as a separate item under this heading in accordance with utility owner's regular procedures. Adequate explanation must be given for total percentage used, especially in those cases where materials and labor are combined as unit costs or where labor percentages include additives and equipment requirements.

### **643.2.9.3.6 Equipment Costs**

A description of the equipment to be used must be shown jointly with the number of hours to be charged. Rates charged for equipment usage must be justified by the utility owner's established accounting procedures. When the utility owner does not have an established accounting procedure or a capitalization and depreciation schedule that is used in its own operations, the rates are to be established by using rental rate publications as a guide. A reasonable amount will be deducted, when using rental rate schedules, for profit that the rental company realizes. A full explanation of the methods used in establishing the rates must also be submitted to support the utility owner's request and with approval of the district utilities staff.

Equipment may be rented when the utility owner's equipment is not available or is inadequate, with the rental rate justified by appropriate solicitation of bids. See [EPG 643.16.2 Construction Contract Requirements](#) for further information.

Unusual accounting procedures may be accepted with adequate prior explanations and approval of the Design Division.

### **643.2.9.3.7 Removal Costs**

These costs are estimated and shown in a similar method but separately from installation costs. When removal costs exceed salvage credits by more than the estimated cost of removal by the roadway contractor, an effort should be made to persuade the utility owner to abandon the utility facilities in place. An exception is made when the utility owner is required to remove abandoned

utility facilities because of liability, hazard, or by specific agreement with the Commission. Abandoned utility facilities can be included with the miscellaneous removals in the roadway contract. It may be possible for the utility owner to remove those portions of the utility facility for which credits will exceed removal costs, with the remainder of the utility facility to be abandoned for removal in the roadway contract. Materials removed must be itemized, with the utility owner's customary salvage credit given. Items to be scrapped or junked should be indicated. Whenever a utility facility or portion thereof is shown to be abandoned on the plan of adjustment, the roadway plans should be notated accordingly. This eliminates ownership problems if these utility facilities are removed or salvaged by the roadway contractor.

When the utility facility is no longer needed and removal is necessary to accommodate the roadway project, the removal of the item may be handled either as a right-of way-item or a utility adjustment. When handled as a right of way item, the damages allowed are to equal the depreciated value of the utility facility, with the necessary removals being accomplished by the roadway contractor. If accomplished as a utility adjustment, the Commission, by utility agreement, will reimburse the utility owner for removal costs and receive salvage credit for the material removed, up to but not exceeding removal costs.

#### **643.2.9.3.8 Salvage of Removed Materials**

This statement, to explain the salvage credit or lack of credit, will reflect routine utility owner policy as well as the particular situation. The utility owner will place a value on any recovered material for salvage. District utilities staff should check this value for reasonableness. Examples of salvage statements include:

- Existing utility facilities to be abandoned in place, since the cost of salvaging, based on our past experience, will exceed their value.
- Only those items will be salvaged for which salvage credit will exceed the cost of removal and salvage.
- Company liability requires removal of the retired utility facilities, even though the cost of removal will exceed allowable credit for salvage.
- Salvage credits are in accordance with established company accounting procedures.

#### **643.2.9.3.9 Accrued Depreciation Credits**

Credit is required for the accrued depreciation of a utility facility that is being replaced. Examples are a building, structure, pumping station, filtration plant, power plant, substation, or other similar operational unit. Credit for accrued depreciation will not be required for a segment of the utility's service, distribution, or transmission lines. It is also not required when the building or structure is being moved as necessitated by the highway project. Acceptable accrued depreciation credit will be determined by using the following formula:

$$\frac{\text{Actual Length of Service of Replaced Facility (Years)}}{\text{Total Estimated Service Life of Replaced Facility (Years)}} \times \text{Original Cost (\$)} = \text{Credit (\$)}$$

#### **643.2.9.3.10 Betterment Credits**

Betterment means the upgrading of the utility facility being relocated, made solely for the benefit of and at the election of the utility owner and is not attributable to the roadway improvement. Credit to the Commission is required for the additional costs incurred for the betterments introduced in the adjusted utility facility. No betterment credit is required for additions or improvements which are:

- Required by the highway project
- Replacement devices or materials that are of equivalent standards although not identical

- Replacement of devices or materials no longer regularly manufactured with next highest grade or size
- Required by law under governmental and appropriate regulatory commission code
- Required by current design practices regularly followed by the utility owner in its own work, and there is a direct benefit to the highway project

### **643.2.9.3.11 Overhead Costs**

Overhead costs are usually a percentage of the total labor cost. This item must be in accordance with the utility owner's established accounting procedures, which in some cases may include handling costs or be a percentage of the total cost of the work involved. Additional attention to overhead costs is required when the rate is different from previously accepted rates. Occasionally, it can be difficult to obtain the necessary information at the time of the estimate to approve the overhead rates. In this situation, the estimate can be approved with exception of the overhead rates for payment. The utility owner is informed of this matter with the understanding that the overhead rates could be approved and paid with submission of appropriate supporting data and Financial Services audit review.

### **643.2.9.3.12 Prorating Costs**

The need for prorating utility adjustment costs occurs when both the Commission and the utility owner are responsible for a portion of the utility adjustment necessary to allow for highway construction, and the actual costs for reimbursement in each category cannot be explicitly determined. Generally, the following conditions require division of costs:

- The adjustment is considered partially reimbursable per [EPG 643.2.8.3](#)
- Betterments are included in the necessary adjustment of the utility facility

The district utilities staff should negotiate with the utility owner's representative to determine an equitable basis for the prorating of costs based on the characteristics of the utility adjustment necessary to allow for highway construction.

### **643.2.9.3.13 Costs Records**

The estimate should include a statement as to where the utility owner's cost records may be reviewed. An example: "Company cost records will be available in our office at 2134 Industrial Avenue, Tulsa, Oklahoma".

### **643.2.9.3.14 Other**

Additional statements will explain or further clarify the work that is included. Such other items may include bypasses, special equipment, need for larger utility facilities, etc.

## **643.2.10 Schedule**

Timely adjustments of utility facilities are essential for efficient completion of highway construction projects. Ideally, all utility adjustments are completed prior to a project's Plans, Specifications, and Estimate (PS&E) submittal to Central Office. Depending on the specifics of the highway construction and utility adjustment necessary, early completion of the utility adjustment may not be practical. The district utilities staff should negotiate with the utility owner to determine the schedule parameters necessary for the utility adjustment. At a minimum, the utility owner should document the dates it anticipates starting and completing the work. If a utility adjustment depends upon the completion of a portion of the highway construction, the necessary milestone for starting the utility adjustment should be documented along with an anticipated number of working days to complete the utility adjustment. The schedule is included as Exhibit "C" to the agreement.

## 643.2.11 Pre-Audits

---

The district utility staff performs a pre-audit review and approval prior to preparation of the agreement. A [pre-audit checklist](#) should be completed and saved in MoProjects.

## 643.2.12 Utility Agreements

---

Whenever the Commission is responsible for the cost of the necessary adjustments to allow highway construction, an agreement is required. If a Master Reimbursable Utility Agreement (see [EPG 643.2.12.2](#)) has not been executed with the utility owner, a Project Specific Agreement (see [EPG 643.2.12.3](#)) is executed between the utility owner and the Commission. In some cases, it may be more practical for the Commission to include adjustment of utilities into a Commission administered contract. A Utility Agreement - Actual Cost (For Utility Work That is to be Included in the Missouri Highways and Transportation Commission's Road Project) (see [EPG 643.2.12.4](#)). Agreements include a plan of adjustment (Exhibit "A"), cost estimate (Exhibit "B"), and schedule (Exhibit "C").

The Utility Agreement boilerplate forms have been approved by the Chief Counsel's Office (CCO). They are identified in the upper left-hand corner of each agreement by an identifier such as CCO Form: UT01 for the Master Reimbursable Utility Agreement. CCO updates these agreements as necessary. They serve as a guide in the preparation of the agreement to be executed with the utility owner for the adjustments required to their utility facilities to accommodate the proposed roadway improvement project. District utilities staff should use the latest version of the agreement found in [eAgreements](#) in drafting an agreement with utility owners. A list of utility agreements and detailed information concerning the sequence for preparing and executing an agreement is available in [EPG 153 Agreements and Contracts](#).

These forms are to be used word for word. Revisions or additions are only made to address specific project details. The intent of each paragraph must be retained, although specific words may be revised to fit the particular situation. No paragraphs are deleted without prior approval from CCO. For guidance on acceptance of liability, refer to the [Acceptance of Liability Policy](#) at the CCO SharePoint page. Drafts of agreements having major revisions or complications are to be submitted, with supporting data, to Design Division for comment and approval.

A reference to 23 CFR 645 is included in all agreements. Utility owners must be acquainted with these requirements and procedures. The incorporation of 23 CFR 645 by reference in all agreements eliminates the need for a second set of regulations to be included in the document.

The agreement for the adjustment of a utility is prepared by the district utilities staff and submitted to the utility owner for execution. The agreement is based on the plan, estimate of cost which was prepared in accordance with 23 CFR 645, and schedule. Authorized individuals representing the utility owner will execute the agreement. The agreement must be signed, sealed, and if necessary, notarized by the utility owner. If the utility owner does not have or use a corporate seal, write "NO SEAL" under the signatures of the owner's officers. Agreements with political subdivisions are to be supported by an appropriate ordinance, a copy of which is to be submitted with the executed agreements. All copies will be forwarded to the CCO for further handling. A fully executed copy of the agreement will be retained in eAgreements. If the agreement was executed using electronic signatures, the district utilities staff should forward an electronic copy of the fully executed agreement to the utility owner. If the agreement was executed using wet signatures, one (1) paper copy of the fully executed agreement will be returned by the Commission Secretary's Office to the district utilities staff. The district utilities staff will forward this copy to the utility owner.

### **643.2.12.1 Buy America Build America Requirements**

All agreements contain information on Buy America Build America (BABA) compliance. The utility owner should select the method of certification (See [EPG 643.2.19](#)) at the time of agreement completion. The appropriate paragraph will be inserted into the agreement. All BABA compliance documents must be retained by the utility owner and made available upon request at no cost to the Commission and/or FHWA.

#### **643.2.12.1.1 Utility Owner Self-Certification**

The City/Company certifies that when determining products/materials subject to Buy America Build America requirements to use in the performance of this Agreement, it shall use only such products/materials for which it has received a certification from its supplier, or provider of construction services that procures the product/material, certifying compliance with Buy America Build America requirements. This does not include products/materials for which waivers have been granted pursuant to 23 CFR 635.410. The City/Company will not be required to provide the Commission copies of the supplier certification as part of this Agreement or with the final invoice of said Commission's Federal-Aid Highway Construction Project.

#### **643.2.12.1.2 Vendor/Manufacturer Certification**

The City/Company certifies that when determining products/materials subject to Buy America Build America requirements to use in the performance of this Agreement, it shall use only such products/materials for which it has received a certification from its supplier, or provider of construction services that procures the product/material, certifying compliance with Buy America Build America requirements. This does not include products/materials for which waivers have been granted pursuant to 23 CFR 635.410. The City/Company shall provide to the Commission all Buy America compliance documents as outlined in the Commission's Engineering Policy Guide 643. All required compliance documents shall accompany the final invoice submitted to the Commission.

### **643.2.12.2 Master Reimbursable Utility Agreements**

The UT01: Master Reimbursable Utility Agreement (MRUA) is a statewide agreement that has been executed by the utility owner and the Commission for all future reimbursable utility adjustments between both parties. Once a MRUA is executed, no other utility agreements are required on design-bid-build projects. The district utilities staff should encourage utility owners to enter into a MRUA with the Commission to reduce potential future delays in executing a project specific agreement. A list of previously executed [Master Reimbursable Utility Agreements](#) is available. District utilities staff should add newly executed agreements to this list. The MRUA can be employed as either an actual cost ([EPG 643.2.12.3.1](#)) or lump sum ([EPG 643.2.12.2.2](#)) agreement. When the reimbursable adjustment will utilize a MRUA, the district utilities staff will prepare a MRUA correspondence letter ("letter agreement") referencing the executed MRUA. A copy of the MRUA correspondence letter should be saved in MoProjects for reference by Financial Services, the district construction office, and the district staff responsible for inspection of utility adjustments. All project specific items such as type of agreement (actual cost or lump sum), plan of adjustment, estimated total cost, cost allocation, and schedule are addressed in the MRUA correspondence letter from the district utilities staff to the utility owner. A [flowchart](#) of the MRUA process is available.

### **643.2.12.3 Project Specific Agreements**

If a utility owner does not have a MRUA with the Commission, a project specific agreement will be required for every project for which the Commission is responsible for the necessary adjustments to allow highway construction. The project specific agreement will be either an actual cost ([EPG 643.2.12.3.1](#)) or lump sum ([EPG 643.2.12.3.2](#)) agreement.

### **643.2.12.3.1 Actual Cost Agreements**

The UT03: Utility Agreement – Actual Cost is used when detailed estimates are not practical or costs appear to be questionable. Details on actual cost estimates can be found at [EPG 643.2.9.2.1 Actual Cost Estimates](#). Once the final invoice on a UT03 is submitted to Financial Services, district utilities staff should change the status on the agreement in eAgreements to completed.

### **643.2.12.3.2 Lump Sum Agreements**

The UT02: Utility Agreement – Lump Sum eliminates the need for keeping detailed records of cost and the auditing of cost records. Estimates of cost must be prepared in detail for use of this agreement. When detailed estimates are not practical or costs appear unreasonable, actual cost agreements are to be used. Use of special forms of agreements, such as "subordination agreements", which are desired by certain utility owners, is acceptable. These, too, must be revised to cover the particular situation. Details on lump sum estimates can be found at [EPG 643.2.9.2.2 Lump Sum Estimates](#). Once the final invoice on a UT02 is submitted to Financial Services, district utilities staff should change the status on the agreement in eAgreements to "completed".

### **643.2.12.4 Agreement for Utility Work Included in Roadway Improvement Project**

The UT04: Utility Agreement - Actual Cost (For Utility Work That is to be Included in the Missouri Highways and Transportation Commission's Road Project) allows for the adjustment to be based on actual cost with the roadway contractor performing the utility work. Caution should be exercised in the type of utilities to be relocated in roadway contracts. Utilities recommended are waterlines and sewer lines. Other utilities, such as gas lines, communication lines, and power lines are to be studied thoroughly before being included in the project.

The Transportation Project Manager and district utilities staff must plan ahead to get this work in the roadway contract. The utility owner must agree to include the utility adjustment in the roadway contract. The adjustment may be on highway right of way or on private easement in the name of the utility owner. The utility owner can agree to allow MoDOT's contractor to work in its easement. However, district utilities staff in consultation with district right of way staff should review the easement documentation to verify the utility owner's rights to the easement and any limitations on its use. MoDOT's contractor can work and operate on both Commission right of way and on the utility easement, even when not directly connected to the Commission right of way, as part of the job site. Temporary construction easements may be necessary in addition to the utility easement to ensure adequate working room for the contractor.

The utility owner may request exemption to any liability for negligence of our contractor working on their easement. The Commission can assume that liability (refer to [Acceptance of Liability Policy](#)), but it should be included in the utility agreement if so desired by the utility owner. A Job Special Provision is necessary to require the MoDOT contractor to hold the utility harmless from all claims due to contractor negligence.

Subsurface information, i.e. boring data, etc., should be obtained by the utility owner since it may be needed for the design of the utility adjustment. This information should be included in the plans. If the utility owner must bear all or part of the cost of the adjustment, the utility owner must agree to pay a pre-deposit to the Commission prior to opening bids on the project. This should be in the utility agreement. The pre-deposit will be credited to the "Missouri Highway and Transportation Commission - Local Fund." Any interest earned in the fund will apply to the cost of the adjustments. The utility agreement will include language that the utility will inspect the installation and assume maintenance of the utility facility after construction. MoDOT will also provide engineering supervision

to be sure the road contractor is in compliance with the contract. Utility plans and specifications are to be approved by the owner prior to submittal to the Central Office. The following items will provide minimum information to allow MoDOT's contractor to bid the work.

1. Individual bid items (not "lump sum") should be established to promote better bidding and to handle overruns and underruns. Bid items not included on the Computer Stored Bid Item list should be "99" numbers.
2. The bid package must be in our letting format. If the package was prepared by a consultant as if the utility owner were going to let it, all bid bond or bidding procedures must be screened to remove requirements contrary to MoDOT letting requirements. District utilities staff should work with the Transportation Project Manager, Design Liaison Engineer, and Central Office Bidding and Contract Services to ensure this requirement is met.
3. The specifications required by the utility owner should be reviewed for items that could cause a bid problem for our contractor. Items such as non-readily available materials or sizes should be avoided.
4. Utility plan sheets should be .pdf files equivalent to 22 in. x 34 in. It is helpful to have a quantity sheet specifically for utility items.
5. Any special procedures required for the utility installation should be included in the Job Special Provisions.
6. The utility package should be submitted on-time to Central Office with other project plans.

### **643.2.12.5 Agreement for a Utility Only Project**

Any of the above agreements can be modified for a utility only project separate from the roadway project. The utility only project may be done by forces hired by the utility owner or by the Commission. A separate utility only project has distinct advantages when the following occurs:

- The utility work is extensive
- It must be performed in accordance with the utility owner's seasonal requirements
- It extends beyond the limits of the construction project
- It must be performed considerably in advance of the roadway contract

Necessary environmental and design work is still required for the limits of the separate utility only project. It may be necessary in these cases to have a second agreement with the utility owner to cover any other work that must be performed concurrently with the roadway contract. These latter agreements will use the roadway construction job number. Early need for utility projects is to be determined at the time when the STIP is updated each year. The utility construction funds will be shown in the year right of way funds are assigned. This will be done whenever possible to secure early adjustment of utility facilities. A request by the district is sent to the Planning Division.

Estimated dollar amounts for utility adjustments are needed. These are estimates and do not need to be extremely accurate. When a special utility project is established, it is preferred, if at all possible, to include all the utility adjustments necessary for the entire roadway project. If funds are available, additional agreements can be added to this utility project until the final invoice for the first completed agreement is received for payment.

### **643.2.12.6 Supplemental Agreements**

For utility owners with a UT01 agreement, a supplemental letter agreement documenting the change in the scope or cost of the work is acceptable.

The UT05: First Supplemental Agreement is used to document changes to UT02 and UT03 agreements. If changes to the scope of work occur that are anticipated to exceed \$100,000 or 15% of the original agreement, a UT05 is required. If the final invoice on an actual cost adjustment

without changes in the scope of work exceeds the limits shown in the table below, a UT05 is required.

Amount in Original Actual Agreement	Final Bill Total Exceeds Original Amount by:
0-\$25,000	50%
\$25,000-\$100,000	40%
Exceeds \$100,000	30%

Should multiple UT05s be required with the same utility owner, the UT05 should be modified for additional supplemental agreements. Once the final invoice on an UT05 is submitted to Financial Services, district utilities staff should change the status on the agreement in eAgreements to “completed”.

## 643.2.13 Utility Adjustments in Roadway Plans and Job Special Provisions (JSPs)

It is the responsibility of the MoDOT Transportation Project Manager (TPM) to ensure utility plans of adjustment are shown on the project plans at the Plan, Specification, and Estimate (PS&E) stage based upon information coordinated by the district utilities staff with the appropriate utility owner.

### 643.2.13.1 Plans

A legend showing all applicable utility symbols and the names of the utility owners is shown on the first special utility sheet. In the absence of special utility sheets, this information may be shown on the title sheet or the first plan and profile sheet. The following note is required to be placed on the title sheet or the first plan and profile sheet and the first special utility sheet (if used) to inform contractors of the suitability of the utility information contained on the plans.

"The existence and approximate location of utility facilities known to exist, as shown on the plans, are based on the best information available to the Commission at this time. This information is provided by the Commission "as-is" and the Commission expressly disclaims any representation or warranty as to the completeness, accuracy, or suitability of the information for any use. Reliance upon this information is done at the risk and peril of the user, and the Commission shall not be liable for any damages that may arise from any error in the information".

### 643.2.13.2 Job Special Provisions

Since the addition of utility information on the plans, supplied by a third party, could subject the Missouri Highway and Transportation Commission to additional liability, a Utility JSP reflecting the status of utility adjustments will be required. The JSP will include the name, address, e-mail address, and telephone number of all utility owner representatives for all utility facilities located on the project. The anticipated adjustment completion date for each utility adjustment is also to be shown based on the agreed upon dates, durations, or completion dates with the utility owner’s representative. This information will inform the bidder of the status of utilities for proper work coordination that could affect the bids for the proposed highway construction project. Status notations will include general notations such as: “N/A”, “Work is in progress”, “Work has not started”, “Work is complete”, and “Work is included in contract.”

### 643.2.13.3 PS&E Submittal

In the District Final Plans Submittal Checklist (D-12), the TPM should note any issues related to existing utility facilities or the adjustment of utility facilities either shown or not shown on the plans. Projects with “No Utility Impacts” such as some overlays, striping, bridge washing, etc. do not need a Utility Status Letter or Utility JSP. The D-12 is used for these projects. In the D-12, under Project Details – “Utilities”, the note “NO” is selected and under “Status”, select “Clear”. For all other projects, the district utilities staff will write a [Utility Status Letter](#). The TPM will include the Utility Status Letter with the submittal of the final plans to the Design Division. The Utility Status will be defined as:

1. Utility facilities are present, but no conflict is anticipated with the highway construction project. Or,
2. All utility facilities requiring adjustment to allow highway construction have been physically adjusted on the project. Or,
3. Utility construction work is planned or active and will be completed to such a point that no impact will be expected to the highway construction project. The status of this work is defined in the utility JSP. Or,
4. Utility facilities are not expected to be adjusted by the notice to proceed date for the road project, but the utility work will have no impact on the progress of the highway construction project. The status of this work is defined in the utility JSP. Or,
5. Utility facilities must be adjusted after the road contractor completes stage construction or in coordination with the contractors’ work. Details of the coordination effort required of the contractor are defined in the utility JSP to properly advise bidders. Or,
6. Utility adjustment plans and specifications are included in the bid documents for the highway construction project. A UT04 agreement must be executed.

## 643.2.14 Payment to Utility Companies for Reimbursable Work

---

Authorization and federal funding obligation must be approved prior to incurring costs. This applies to all types of work on utility facilities including preliminary engineering. An obligation is a commitment by the federal government to reimburse MoDOT for the federal share of a project’s eligible cost.

### 643.2.14.1 Obligation Process

Federal funding can be used with both lump sum and actual cost agreements. After the utility agreement is fully executed, the district utilities staff will email a copy of the utility agreement or the letter agreement referencing the MRUA to the email group OBLIGATE. This email should request the authorization authority for use of federal funds and to be informed of a Notice to Proceed (NTP) (see [EPG 643.2.15](#)) date by Financial Services once federal funding has been obligated. District utilities staff should allow three (3) weeks to receive the NTP. Financial Services will use Advance Construction (AC) funding to fund reimbursement to utility owners. With AC funding, state funds initially are used to pay for reimbursement to utility owners. Once construction is complete, with appropriate documentation of the work via the [C-9](#) and [C-13](#), Financial Services will convert to federal funding.

### 643.2.14.2 Preliminary Engineering

On occasion, preliminary engineering (PE) may need to be undertaken by the utility owner prior to the execution of a utility agreement. If a utility owner has a MRUA, an estimate of the cost of the PE work by the utility owner may be used to obligate funding for preliminary engineering under the MRUA as a PE only letter agreement. If a lump sum or actual cost agreement will be required with

the utility owner for the project, district utilities staff should do two (2) agreements with one agreement covering PE only, and once a design for the adjustment is obtained, a second agreement for the construction of the adjustment should be executed. If a separate PE only agreement is obtained, NTP will need to be issued twice to the utility owner: once for PE and once for construction.

### **643.2.14.3 Right of Way**

Once Notice to Proceed has been given, the utility owner may begin the right of way acquisition process. If the utility owner needs to acquire right of way prior to a full agreement for relocation has been negotiated, the agreement specifically for the acquisition of right of way should be executed. This agreement will be sent to Financial Services to begin the obligation process.

### **643.2.14.4 Construction**

Payment to utility owners for construction of the adjustment may occur in a number of phases.

#### **643.2.14.4.1 Prepayment**

Per the utility agreement, the Commission allows utility owners to be prepaid prior to commencing work. The district utilities staff may negotiate the prepayment if the utility owner is receptive. The utility owner will submit a request for prepayment with an invoice prior to any prepayment. Route, county, and job number must be included in the request. The district utilities staff will submit a request to Financial Services with a copy saved in MoProjects for future reference by the district staff responsible for inspection of the utility adjustment.

#### **643.2.14.4.2 Progress Payments**

If a utility owner has not been prepaid the entire estimated amount in the utility agreement, then the utility owner may request progress payments after completing a portion of the proposed work, including PE.

Progress payments for PE by consultants should not exceed the "maximum not to exceed amount" shown in the cost estimate unless additional costs are approved first by district utilities staff.

For progress payments, the utility owner is required to submit only a summary of work and materials for which payment is claimed, not a detailed billing. District utilities staff should check only to be sure that sufficient work has been done to justify making the requested payment. Payment should be made for allowable costs incurred up to the date of the progress payment request.

Progress payment invoices do not relieve the utility owner of the responsibility of submitting one complete and final invoice upon completion of the adjustment. The utility owner's address must be shown on the invoice. The district utilities staff should submit progress payment invoices and applicable C-9s to Financial Services within one (1) week of receipt of invoice.

One copy of the progress payment and one copy of the district utilities staff letter of recommendation must be sent to Financial Services for payment and be stored in MoProjects. The cover memo should include the project number, route, county, actual cost or lump sum utility agreement, Commission obligation percentage, total cost estimate of Commission obligation, and indicate the progress payment number, i.e., progress payment number 1, 2, 3, etc. If more than one progress payment is requested by the utility company, the district should submit progress payment bills to Financial Services in the following format:

<b>Payment</b>	<b>Amount</b>
Progress Payment #1	\$50,000

Progress Payment #1	\$10,000
Total Payment to Date	\$60,000

This format will help clarify payment history with the utility owner. Progress payments for actual cost utility agreements may not exceed the Commission's total estimated cost shown in the agreement. However, if the request for a progress payment exceeds the original estimate, a change order with explanation should accompany the request. (See [EPG 641.2.16.5 Change Orders](#).)

### 643.2.14.4.3 Final Payment

Utility owners are required to submit a detailed final invoice to MoDOT for all actual cost reimbursable utility work and for any lump sum reimbursable utility work that was not prepaid. For prepaid lump agreements, the utility owner must submit a zero-dollar (\$0) invoice to demonstrate the work has been completed. After the utility work has been fully completed, the district utilities staff responsible for inspection should send the utility owner a "60 Day" [Final Acceptance Letter](#) requesting a complete final invoice within 60 days, as detailed in the utility agreement. If the final invoice is not received from the utility owner within 30 days, then a follow up letter should be sent (i.e., "30 Day" [Reminder Final Invoice Letter](#)) reminding the utility owner of its obligation to submit a final invoice within 60 days of the completed work. If a final invoice from the utility owner is not received within this timeframe, then the district utilities staff should contact the Design Liaison Engineer for guidance on how to close out the work.

The district utilities staff is expected to check the final bill within two (2) weeks after receipt in as much detail as possible against the C-9. It is their responsibility to verify from field records the quantities of labor, equipment, material used, material retired, and to justify all changes made. If the utility owner's contractor made the adjustment at unit cost prices, then it is the district utility staff's responsibility to verify the number of units completed and not the hours of labor and equipment. It is also important for the utility owner to show the words "final bill" or "final invoice" on the last bill, in order for MoDOT to understand that no additional charges will be made on the adjustment. The final bill must show a general description of the utility adjustment, the highway project number, the date on which work was completed or last item of billed expense was incurred, and the location where records can be audited. The order of items in the final statement should follow as closely as possible the order of items in the original estimate. A summary, on the utility owner's letterhead, of the total cost of preliminary engineering, construction engineering, right of way, labor, overhead, construction travel expense, transportation, equipment, materials, supply, handling, and salvage credits should be shown in a way that will permit direct comparison with the approved estimate from the original or supplemental agreements (see [EPG 643.2.12.6](#)).

If the Actual Cost final invoice shows a much higher cost than the original estimate without scope change, the utility owner is required to give reasons in a letter to the district utilities staff explaining why the invoice cost increased. When the Actual Cost final invoice exceeds the amount shown in the table in [EPG 643.2.12.6](#), a supplemental agreement is required.

When the district utilities staff has determined that the final invoice is accurate, the C-13 should be completed. Once the C-13 is completed, the C-13 and the final invoice from the utility owner are forward to Financial Services. For Actual Cost agreements, the C-9s should also be included in this transmittal. If no additional payments are required, the district utilities staff should note this in the transmittal as well. If the final invoice indicates previous payments to a utility owner exceeded the final invoice, the utility owner will need to send MoDOT a check for the overpayment amount. The check should be made payable to Director of Revenue – Credit State Road Fund. If the utility owner did not send MoDOT an overpayment check with the final invoice, district utilities staff should send a letter to the utility owner requesting the refund amount. Submittal of the final invoice to Financial

Services should not occur until repayment has been received. The submittal to Financial Services should note the receipt of the repayment check.

## 643.2.15 Notice to Proceed

---

For PE only, once an agreement has been executed, and Financial Services has advised that authorization from FHWA has been received, district utilities staff will issue a notice to proceed (NTP) letter to the utility owner for the PE. For agreements that include PE and construction or once a final agreement for construction has been executed, right of way clearance has been issued, and Financial Services has advised that authorization from FHWA has been received, the district utilities staff will issue NTP to the utility owner for construction. See [Example of Notice to Proceed Letter](#). If salvage credit is part of the agreement with the utility owner, the NTP letter should include a statement that the utility owner will need to inform district utilities staff of the time and place that inspection may be made of the removed material. The utility owner may be held accountable for full value of materials disposed without proper notice. Utility owners may purchase materials prior to NTP for construction; however, no other work on the adjustment necessary to allow highway construction may begin prior to NTP for construction. The utility owner, for reasons of planning their workload or due to seasonal situations, may request early authorization to perform the work. This request, with the district utilities staff recommendations, is sent to the Design Liaison Engineer for further handling, approval, and advancement of the necessary funds. A copy of the NTP should be saved in MoProjects. If a utility owner begins adjustments prior to NTP for construction, district utilities staff should notify the utility owner immediately in writing that reimbursement will not be made for work done prior to NTP for construction.

## 643.2.16 Construction of Utility Adjustments

---

### 643.2.16.1 Utility Owner Self-Perform

As per 23 CFR 645.115 Construction, it may be cost-effective for certain utility adjustments to be performed by a utility owner with its own internal forces and equipment, provided the utility owner is qualified to perform the work in a satisfactory manner. This cost-effectiveness finding covers minor work on the utility owner's existing utility facilities routinely performed by the utility owner with its own forces.

### 643.2.16.2 Construction Contract Requirements

When the utility owner is not adequately staffed and equipped to perform such work with its own forces and equipment at a time convenient to coordination with the associated highway construction, such work may be done one of four ways for utility adjustments:

1. MoDOT can provide the construction services, via awarded contract to the lowest qualified bidder based on appropriate solicitation. This can be done by including the adjustment work in the roadway improvement project ([EPG 643.2.12.4 Utility Agreement for Utility Work Included in Roadway Improvement Project](#)) or by having a utility only project ([EPG 643.2.12.5 Utility Only Project](#)).
2. The utility owner can award a construction contract to the lowest qualified bidder based on appropriate solicitation.
3. The utility owner can utilize an existing continuing contract, provided the costs are reasonable (see [EPG 643.2.9.1 Independent Cost Estimate](#)).
4. The utility owner can contract for low-cost incidental work, such as tree trimming and the like, without competitive bidding, provided the costs are reasonable (see [EPG 643.2.9.1 Independent Cost Estimate](#)).

When a utility owner chooses option 2 to award its own new construction contract, the utility owner must provide the following documents and information to the district utilities staff. These documents need to be provided as soon as the utility owner has chosen to pursue a construction contract. Document 1 must be supplied by all utility owners. Documents 2 and 3 are only required when the utility owner is a local government agency who is also a political subdivision of the state of Missouri (e.g., city-owned utilities, county-owned utilities). All other utility owners are encouraged, but not required, to provide Documents 2 and 3.

1. A statement that the utility owner is not staffed or able to perform the required construction activities with its own forces.
2. A copy of the request for proposal used to secure bids.
3. A list of a minimum of 3 bidders whom they believe can do the work. **Political subdivisions are required to advertise for the work.**
4. Upon review of these documents, the district utilities staff will advise the utility owner to proceed with the solicitation of bids, but the utility owner will not be permitted to award the contract without the concurrence of district utilities staff. For lump sum agreements, approval of contract work and subcontract work is not required.

The following documents need to be provided as soon as the utility owner has determined the lowest qualified contractor and would like to award the project. Document 1 must be supplied by all utility owners. Document 2 is only required when the utility owner is a local government agency who is also a political subdivision of the state of Missouri (e.g., city-owned utilities, county-owned utilities). All other utility owners are encouraged, but not required, to provide Document 2.

1. The name address of the lowest qualified contractor.
2. The tabulation of bids received and other information to support their recommendation for award to the lowest qualified bidder.

The district utilities staff will review and approve the utility owner's bid information prior to the award of the contract. The Design Liaison Engineer is available to assist the district with review of bid information if necessary. Once the district utilities staff provides concurrence, the utility owner may proceed with awarding the contract. When the utility owner is a local government agency who is also a political subdivision of the state of Missouri (e.g., city-owned utilities, county-owned utilities), a copy of the executed contract must be shared with the district utilities staff. All other utility owners are encouraged, but not required, to provide a copy of the executed contract.

A **checklist** is available for reviewing contracts to ensure the contract conforms to MoDOT policy and complies with applicable federal regulations.

When a utility owner chooses to utilize a an existing continuing contract, the utility owner will submit a copy of the contract to the district utilities staff. The district utilities staff will review the contract for reasonableness of cost. If district utilities staff and the utility owner's representative cannot agree on the reasonableness of cost, then the utility owner will be required to award a new construction contract.

### **643.2.16.3 Inspection**

The degree of inspection needed for utility adjustments will vary considerably with the nature and location of the work and whether the Commission is responsible for any portion of the cost of reimbursement. Judgment must be used regarding the manner and regularity of inspection duties. Some phases of the work require a very close check to ensure that the highway will not be adversely affected and to ensure satisfactory performance of work in accordance with the agreement and plans. The degree of inspection may vary from spot checking of overhead installations to continuous

close observation of backfilling trenches beneath proposed pavement, embankment area, or adjacent to bridge abutments. Proper inspection can ensure that the utility adjustment is completed as efficiently as possible to minimize future impacts to the utility facility and the highway construction project. A **Field Inspection Checklist** to assist district utilities staff responsible for inspection is available.

If it is found that any actual cost reimbursable utility adjustment is being performed by unapproved contractors, district utilities staff should direct the work to stop. The utility owner's representative should be informed immediately and should be advised in writing that the costs incurred by an unapproved contractor are not eligible for reimbursement under provisions of the agreement. The district utilities staff can take appropriate steps to approve a subcontract and advise when the utility owner can recommence work.

### **643.2.16.4 Documentation**

All documents related to the construction of the utility adjustment necessary to allow highway construction should be stored in MoProjects.

Construction records must be kept to confirm that work is done in accordance with the terms of the agreement and in the manner proposed in the plans. The importance of a complete and accurate record cannot be overemphasized. Detailed records are necessary to support the recommendation for payment of the final invoice. A complete, separate daily record must be kept on each actual cost adjustment and submitted for review when the final invoice is recommended for payment. This district utilities staff responsible for inspection should complete the Daily Utility Report (C-9).

#### **643.2.16.4.1 Utility Reports**

The Daily Utility Report (**Form C-9**) and the Final Utility Report (**Form C-13**) are used for documenting utility adjustments necessary to allow highway construction. The use of C-9s and C-13s will vary with method of reimbursement. For utility adjustments necessary to allow highway construction that overlap with the highway contractor's work, progress records should be kept as necessary to coordinate the highway and utility construction activities. Sufficient records must be maintained to check and verify the items of labor, equipment, materials, and salvaged items as submitted on the final invoice.

##### **643.2.16.4.1.1 Daily Utility Report (C-9)**

C-9s are only required for actual cost agreements. The district utilities staff responsible for inspection must in all cases keep records to document inclement weather, down time, and verbal authorization for minor changes. The district utilities staff responsible for inspection must complete a C-9 documenting the number and classification of employees and number of hours worked. Records of material used and of retired materials returned to stock or scrapped must be kept. The utility owner's major items of equipment must also be recorded. When work is done by the contract method based on unit prices, the district utilities staff responsible for inspection should ascertain that units of work as provided in the bid proposal are measured and recorded to form a basis for checking the final invoice. C-9s should list the location and the number of units of work accomplished for that period. If contract labor or equipment is used by a utility owner on the basis of a bid per hour, per day, etc., it will be necessary to keep records on this labor or equipment time in the same manner as if the utility owner were performing the work with its own internal forces. District utilities staff responsible for inspection should also note all contractors working for the utility owner and the contractor approval authorization dates given in the agreement.

#### **643.2.16.4.1.2 Final Utility Report (C-13)**

C-13s summarize that the utility adjustment work that was done in accordance with the agreement and plans, the percentage of total cost that is the responsibility of the Commission, and any progress payments that have been made. A C-13 is required for both actual cost and lump sum agreements. The requested numbers shown on line 9 (Commission Estimated Cost) and line 10 (Amount of Final Bill) in the report are the Commission's total responsibility.

#### **643.2.16.4.2 Breakdown and Emergency**

When breakdown and emergency situations occur, prior approval by MoDOT is not required for contract or equipment rental work unless the cost or period of time will be extensive. The utility owner should furnish a letter as soon as possible to explain the situation and set out the estimated costs involved. The district utilities staff's records should substantiate the need and the changes for personnel and equipment.

#### **643.2.16.4.3 Stop Work**

If at any point, a stop work order is given by MoDOT to a utility owner, written documentation of the stop work order should be saved in MoProjects.

#### **643.2.16.5 Change Orders**

Any change in the plan of adjustment should be documented in writing to the utility owner as a change order. If the change order is anticipated to exceed \$100,000 or 15% of the original agreement amount, district utilities staff should negotiate a supplemental agreement with the utility owner's representative. Once a supplemental agreement is in place, district utilities staff should contact Financial Services to obtain an adjustment of the obligation mid-project. Change orders without supplemental agreements will be settled once the project is complete.

#### **643.2.16.5.1 Actual Cost Agreement**

Slight modifications in quantities or the addition of minor items not included with the original agreement do not require a supplemental agreement. However, such changes should be documented in writing with the utility owner. A supplemental agreement is needed if costs exceed the above threshold or if there is a change in the percentage of cost that is the Commission's responsibility on an agreement with shared responsibility for costs. Intermediate partial payments cannot be made on items in a supplemental agreement until the supplemental agreement is approved.

#### **643.2.16.5.2 Lump Sum Agreement**

A supplemental agreement to a Lump Sum Agreement is only required for significant changes in the scope of work of the utility adjustment necessary to allow highway construction. Normal overruns are not considered as changes in approved work and will not be reimbursed. Significant changes in the scope of work on utility adjustments necessary to allow highway construction cannot be done until the supplemental agreement is approved, and the adjustment in obligation of funds is complete.

### **643.2.17 Utilities during Highway Construction**

---

The contractor is responsible for having utilities located by contacting Missouri One-Call (811) prior to any excavation on the project. A reminder of this responsibility should be made at the preconstruction meeting.

#### **643.2.17.1 Preconstruction Meeting (Pre-Con)**

District utilities staff should be invited to all pre-cons.

Pre-cons fall into three categories relating to utilities:

1. No utility adjustments are anticipated within the project limits,
2. All utility adjustments completed prior to the pre-con, and
3. All utility adjustments not completed prior to the pre-con.

### **643.2.17.1.1 No Utility Adjustments Anticipated within the Project Limits**

For projects without a Utility Job Special Provision (JSP), no involvement of the utility owners is required at the pre-con. For projects with a Utility JSP, the Resident Engineer (RE) should invite all utility owner representatives listed in the JSP with known required adjustment to the pre-con. The RE should review potential impacts of the highway construction project with the contractor and the utility owner.

### **643.2.17.1.2 All Utility Adjustments Completed Prior to the Pre-Con**

The RE should invite all utility owner representatives listed in the JSP with known required adjustment to the pre-con. The RE should review potential impacts of the highway construction project with the contractor and the utility owner. A general discussion should highlight the previous adjustments made by the utility owner and what abandoned utility facilities the contractor may encounter.

### **643.2.17.1.3 All Utility Adjustments Not Completed Prior to the Pre-Con**

It is important for the RE and inspector to understand the utility owner's work schedule and how it relates to the contractor's work schedule. During the pre-con, the schedule of the utility owner and highway construction contractor should be discussed, and conflicts should be addressed to allow utility adjustments and highway construction to progress as near to the proposed schedule as possible. On large-scale projects that have many utility issues to address that could impact the work of the highway construction contractor, it may be necessary to have a separate pre-con with utility owner representatives.

### **643.2.17.2 Coordination Meetings**

When the utility work will not be completed soon after the preconstruction meeting, the RE should meet with district utilities staff, the highway construction contractor, and the utility owner representatives on a regular basis to discuss utility coordination issues, so expectations from all parties are known and conveyed clearly. The utility owner may need some work performed by MoDOT or the highway construction contractor prior to completing their adjustments. (Examples include: survey staking of right of way or proposed facilities, trees cleared, grading performed, or new structures built).

## **643.2.18 Service Drops**

---

Power and communication services provided by utility owners are necessary for the operation of the highway system. These services may include power to traffic signals, lighting, or ITS devices; power for cathodic protection; or telecommunication services to signal controllers or ITS devices. The project design teams should work with district utilities staff to identify proper locations for the applicable utility owners to provide these services. Various utility owners have different requirements for this process. The district utilities staff is encouraged to develop a workable relationship with the utility owners who provide these services to MoDOT. The costs of installing the services charged by the utility owner are considered a non-contractual item and should be accounted for in the project's

budget in the STIP. The proposed location and method for the service drops should be shown on the roadway plans. District utilities staff should meet with the utility owner's representative to ensure the proposed location can be accommodated by the utility owner. For electrical service connections, the power supply assembly is ideally located a maximum of ten feet (10') from the source location. Plans submitted for PS&E should reflect the agreed upon location for all service connections. During construction, district utilities staff and district construction staff should work together to ensure the placement of the services is consistent with the project plans. Payment for the service drops should be invoiced by the utility owner to the district. District utilities staff is responsible for submission of the invoice directly to Financial Services for payment noting the non-contractual charges for the project.

## 643.2.19 Buy America Build America for Utilities

---

FHWA's Buy America Build America (BABA) policies require a domestic manufacturing process for all steel or iron products, other construction materials, and manufactured products that are permanently incorporated into Federal-Aid Highway construction projects, including products and materials used for adjustments to utility facilities to allow highway construction. These guidelines are for all federally reimbursable transportation projects where FHWA is the lead federal agency; it does not take precedence over projects where Federal Transit Administration or the Federal Railroad Administration is deemed to be the lead federal agency.

### 643.2.19.1 Program Requirements for Utilities

All MoDOT projects are federal-aid projects, and therefore, all reimbursable utility adjustments are required to follow the provisions of BABA. More information on MoDOT's BABA policy and procedures can be found in [EPG 106.9 Buy America Requirement](#). Specifically, utility owners should be aware of the following procedures for determining applicability of the EPG 106.9 requirements to reimbursable utility adjustments necessary to allow highway construction:

- BABA does not apply when materials are relocated from one location to another within the project limits.
- BABA does not apply for materials necessary for temporary utility adjustments assuming materials are removed from the right of way upon completion of the utility adjustment to allow highway construction.
- Non-reimbursable work must be kept separate from reimbursable work (agreements, permits, etc.) in order to not be subject to BABA.

### 643.2.19.2 Certification Requirements for Utilities

Utility owners have the option of choosing either to self-certify BABA compliance or provide vendor/manufacture certification to MoDOT. The method of certification is chosen by the utility owner and is documented in either the MRUA or the project specific agreement. Regardless of agreement type or certification method, the utility owner must be compliant with BABA requirements.

#### 643.2.19.2.1 BABA Utility Owner Self-Certification

If a utility owner chooses to self-certify BABA compliance, the utility owner is not required to provide MoDOT copies of the supplier certification as part of the project documentation or with the final invoice for any reimbursable utility adjustment necessary to allow highway construction. Retention of all documents should be as described in the agreement.

#### 643.2.19.2.2 BABA Vendor/Manufacturer Certification

If a utility owner chooses to use vendor/manufacture certification, the utility owner will supply MoDOT BABA compliance from all vendors and/or manufacturers. Certification from vendors will be signed by an authorized representative of the vendor on company letterhead or other acceptable documentation and will declare that all supplied materials subject to BABA requirements are fully compliant. Certification from iron or steel manufacturers must be in the form of a mill test report (MTF) issued and signed by the initial fabricator stating the materials subject to BABA were melted and manufactured in the United States. Other written statements on company letter or other acceptable documentation signed by an authorized representative of the manufacturer for any additional treatment to the fabricated material (such as blasting, galvanizing, painting, or coating) will state that all treatment processes occurred in the United States according to FWA guidelines. Retention of all documents should be as described in the agreement. Manufacturer certification for manufactured products or construction materials will state that all materials were sourced from the United States and were fabricated in the United States. Retention of all documents should be as described in the agreement.

## 643.3 Reserved for Future Use

## 643.4 Railroads

---

**NO CHANGE**



### **236.5.29 License Plate Readers (Note: this is a new article in 236.5 Property Management)**

Automated License Plate Readers (LPRs) and Pan-Tilt-Zoom cameras (PTZs) are an increasingly popular way for law enforcement to better locate vehicles associated with criminal activity. The deployment of these devices on Commission right of way require FHWA approval and shall not create a safety risk for the traveling public or interfere with MoDOT's ability to maintain and operate the transportation system.

The general process for LPR and PTZ requests is outlined in section 941.10.

It is the requesting law enforcement agency's responsibility to contact MoDOT's local traffic permit specialist to initiate the permitting process, after approval from Department of Public Safety (DPS) has been received. The local district traffic representative will work with the applicant through the permitting process.

Once the district traffic staff determine the LPRs or PTZs are eligible to be deployed on Commission right of way, the district traffic staff will forward the drafted permit via the permit database to Central Office Right of Way (COROW). CO ROW will then gather the following items to seek FHWA approval:

- Cost estimate including the device and pole, and fair market value of the device location
- Environmental clearance -categorical exclusion approval

Once COROW gathers the items listed above, they will include the following items in their submittal to FHWA for approval.

- FHWA LPR Nonhighway Use Request Letter
- DPS approval letter
- Roles and Responsibilities document
- Plans including type and location of equipment to be installed

Upon receiving FHWA approval, COROW will upload the FHWA approval documentation in the permit database and notify the district traffic staff they may proceed with issuing the permit. If FHWA does not approve, the permit cannot be issued.

### 941.10.1 Approval Process

The general process for LPR and PTZ requests are outlined in the [LPR Flowchart](#). Law enforcement agencies must request approval, in writing, for deploying LPRs and PTZs from the [Director of the Department of Public Safety](#). Requests are to be on the law enforcement agency letterhead and emailed to the Department of Public Safety at [dpsinfo@dps.mo.gov](mailto:dpsinfo@dps.mo.gov).

The Department of Public Safety (DPS) provides approval for the use of LPR and PTZ devices. MoDOT only facilitates the administration of work by others on Commission right of way. [MoDOT's permitting process](#) will be followed for the constructability and maintenance of the devices to ensure the safety of the traveling public. If an issue is identified through our normal permitting process and cannot be resolved, a permit for this work will not be issued.

It is the requesting law enforcement agency's responsibility to contact MoDOT's local permit specialist to initiate the permitting process, after approval from DPS has been received. Contact information for MoDOT's local permit specialists can be found using the District Permit Maps.

The local district [traffic](#) representative will work with the applicant through the permitting process. The permit request submittal must include:

- An aerial image, or map, depicting all the individual LPR locations included in the submittal.
- An aerial image for each LPR location included in the submittal clearly showing where the proposed installation with respect to the roadway and other structures on the right of way.
- A set of drawings, or plans, showing the hardware and their installation details proposed on the right of way, which must be signed and sealed by a Missouri Professional Engineer (P.E.).
- This applies to stand alone installations as well as installations on approved existing structures on right of way, such as signal and sign truss uprights.
- Executing a Roles and Responsibilities document to specifically address the expectations of maintaining the devices being installed.
- A plan to provide electricity to the equipment as well as retrieving data from the equipment.
- A traffic control plan for any proposed work on the right of way to notify and guide motorists safely through the activity area.

- A surety deposit or performance bond to insure satisfactory work, accepted by MoDOT.

A separate permit may be provided for the applicant, or their consultant, to access the right of way to collect information needed to develop a set of plans for installing the devices.

### **941.10.2 Location**

When receiving a request, the district [traffic staff](#) will work with the law enforcement agency to determine if there are acceptable locations for the proposed installations off MoDOT right of way. If there are no appropriate locations off of right of way, the district [traffic staff](#) will work with the agency to determine if the LPRs and PTZs requested can be deployed on Commission right of way.

LPR and PTZ installations on Commission right of way shall only monitor traffic on MoDOT roadways and shall not be used to monitor off system roadways, such as county, city, or private facilities.

[Once the district traffic staff determine the LPRs or PTZs are eligible to be deployed on Commission right of way, the district traffic staff will forward the drafted permit via the permit database to Central Office Right of Way \(COROW\). See section 236.5.29 for COROW's review and process for requesting FHWA's approval.](#)

[Upon receiving FHWA approval, COROW will upload the FHWA approval documentation in the permit database and notify the district traffic staff they may proceed with issuing the permit. If FHWA does not approve, the permit cannot be issued.](#)

#### **941.10.2.1 LPR and PTZ Non-Permanent Installations - Speed Enforcement Trailers**

The only form of non-permanent structure that LPR and PTZ devices may be deployed on, when placed on Commission right of way, are speed trailers. However, speed trailers shall only be deployed for the primary purpose of speed enforcement and not for the primary purpose of deploying LPR and PTZ devices. When speed trailers are deployed, the electronic speed message must be active and the unit deployed and delineated in accordance with [EPG 907.8 Speed Trailers Deployed by Others](#).

### 941.10.2.2 LPR and PTZ Permanent Installations

To ~~assure~~ ensure LPR and PTZ devices do not represent an added risk to the traveling public, there are defined installation locations which are acceptable on Commission right of way. Acceptable installation locations include:

- Only deployed on the right side of the roadway outside of the shoulder.
- On MoDOT traffic signal upright poles, except in instances where deployment will interfere with other devices already attached to the pole.
- On MoDOT overhead sign truss upright poles.
- On any non-breakaway structure owned by a third party, with the written permission of the third party.
- On independent ~~signal pedestal base poles support~~ behind barrier (installed and maintained by requesting agency or their LPR vendor) in accordance with the guidance in EPG 941.10.2.2.3. LPR Independent Installation Typical Application.
- On independent breakaway support that has been crash tested by the LPR vendor and approved by MoDOT. ~~The following is~~ See EPG 941.10.2.2.3 for a list of approved systems~~(s)~~.
- ~~Flock Safety Breakaway TA.~~
- ~~On any non-breakaway structure owned by a third party, with the written permission of the third party.~~

Locations where LPR and PTZ devices shall not be installed include, but are not limited to:

- Any installation in the median / left side of a divided highway.
- Any overhead location.
- On any existing structure on right of way which has a breakaway design, whether it is owned by the Commission or a third party.
- Any bridge structure.
- Any location that already has a device installed.
- Any location that may interfere with MoDOT's ability to manage the transportation system.

MoDOT does not allow the deployment of LPR and PTZ devices overhead or in the median as these locations would result in increased impact on the safety and mobility of the

traveling public when performing installation and maintenance activities. LPR and PTZ devices are not permitted on any existing structure which is designed as a breakaway device on Commission right of way, regardless of ownership, as the addition of these devices could negatively impact the performance and safety of the breakaway structure.

There are three methods identified for deploying LPR and PTZ devices on Commission right of way, all of which must be approved by MoDOT and installed under a MoDOT permit:

- LPRs and PTZs installed on MoDOT structures.
- ~~LPRs and PTZs installed on non-MoDOT structures. -with the written permission of the structure owner.~~
- LPRs and PTZs installed on new stand-alone structures. ~~-installed and maintained by the requesting agency or their vendor in accordance with the LPR Independent Installation Typical Application or Flock Safety Breakaway TA.~~
- ~~LPRs and PTZs installed on non-MoDOT structures - with the written permission of the structure owner.~~

#### **941.10.2.2.1 LPRs and PTZs Installed on MoDOT Structures**

LPRs and PTZs can be attached to MoDOT's existing traffic signal upright poles and existing sign truss upright poles upon review and approval by MoDOT.

#### **941.10.2.2.2 LPRs and PTZs Installed on non-MoDOT Structures**



There are some structures that have been permitted on Commission right of way which are owned by other entities, such as structures for weigh station bypass equipment or utility poles. Law enforcement agencies have the option to acquire approval from the owners of the structures to utilize them as supports for their LPR and PTZ devices if they meet the following criteria:

- The structure must be reviewed and approved by MoDOT for use.
- Written permission from the owner of the structure must be acquired and supplied to MoDOT.

- Any structure which is of a breakaway design, such as roadway lighting poles or highway signs, are not acceptable support structures.
- Installation location criteria listed in [EPG 941.10.2.2](#) also apply to these structures.

### 941.10.2.2.3 LPRs and PTZs Installed on New Stand-Alone Structures

To limit the number of structures on Commission right of way, opportunities to locate the LPRs and PTZs off of right of way is the preferred option, followed by an installation location on an existing structure already on right of way. If it is determined a new stand-alone structure is required to facilitate the LPR and PTZ deployment, the following guidance shall be followed:

- The district [traffic](#) shall work with the local agency to find a location which meets the requirements outlined on the ~~[MoDOT License Plate Reader Independent Installation Typical Application](#)~~  [General LPR Typical Details Application -11-25-25.pdf](#) or ~~[Flock Safety Breakaway TA](#)~~  [Flock LPR Stand Alone Install Typical Details V4.pdf](#).
- Stand-Alone LPR and PTZ structures shall be properly spaced away from other traffic control devices, which can include but are not limited to highway signs, traffic signal, roadway lighting poles, etc.:
  - No closer than 200 feet upstream of a traffic control device.
  - No closer than 50 feet downstream of a traffic control device.
- Installation and maintenance access should be via adjacent private property or secondary roadways for divided highway, unless physically impossible.

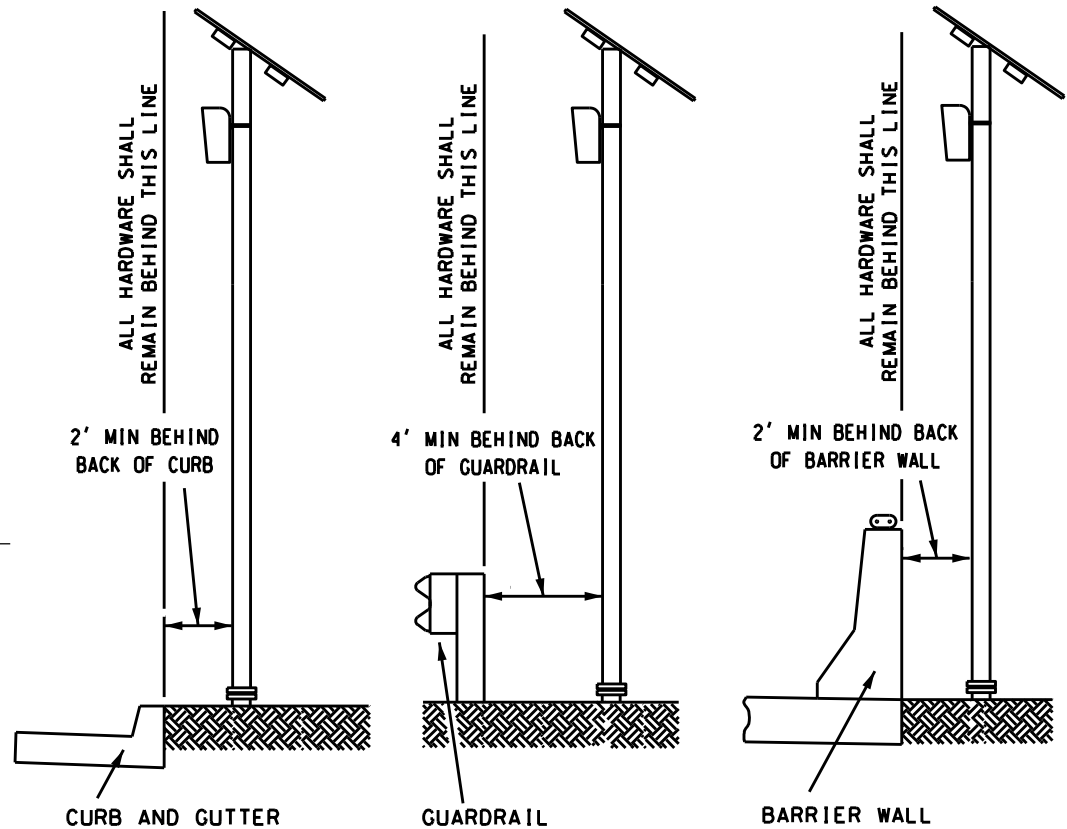
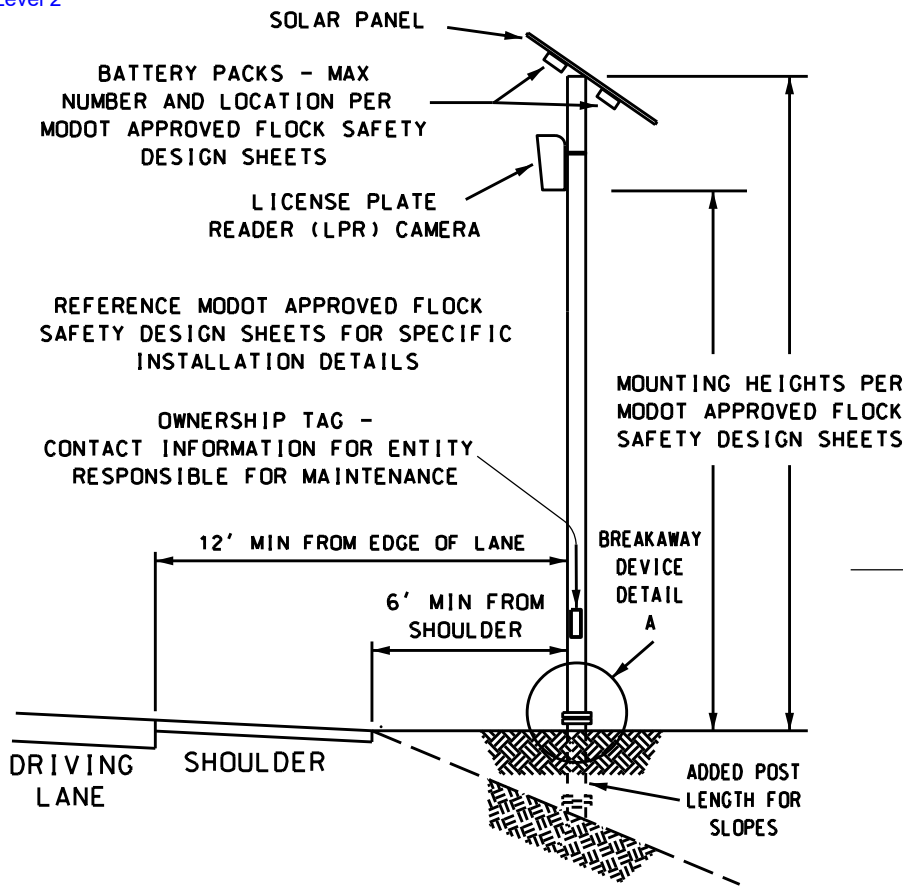

THESE REQUIREMENTS APPLY TO TWO FLOCK SAFETY LPR SUPPORT SYSTEMS  
 - FLOCK PROVELI BREAKAWAY SYSTEM  
 - FLOCK REDI-TORQUE BREAKAWAY SYSTEM

- 1) NO OTHER DEVICES BESIDES THE LICENSE PLATE READER CAMERA AND SOLAR PANEL/BATTERY MAY BE MOUNTED TO THE SUPPORT POST
- 2) NO PORTION OF BREAKAWAY DEVICE FIXED TO THE GROUND SHALL BE MORE THAN 4" ABOVE FINISHED GRADE, SEE DETAIL A
- 3) THE INSTALLATION AND HARDWARE SHALL EXACTLY MATCH THE MODOT APPROVED FLOCK SAFETY DESIGN SHEETS
- 4) NO REMOTE BATTERY BOX MAY BE UTILIZED WITH THIS CONFIGURATION
- 5) INSTALLATIONS SHALL NOT BE PLACED ON SLOPES WITH GRADES STEEPER THAN 3:1
- 6) INSTALLATIONS SHALL NOT BE PLACED IN THE FLOW LINE OF DRAINAGE DITCHES
- 7) INSTALLATIONS SHALL NOT BE PLACED WITHIN 200 FEET UPSTREAM OR 50 FEET DOWNSTREAM OF ANY OTHER ROADWAY STRUCTURE
- 8) IF INSTALLED BEHIND A BARRIER, THE INSTALLATION SHALL BE A MINIMUM OF 50 FEET FROM THE BARRIER END
- 9) THE OWNERSHIP TAG SHALL BE FABRICATED TO LAST THE LIFE OF THE INSTALLATION AND SHALL CONTAIN THE AND CONTACT INFORMATION OF THE ENTITY RESPONSIBLE FOR MAINTAINING THE INSTALLATION
- 10) SEE MODOT EPG SECTION 941.10 FOR COMPLETE GUIDANCE ON LICENSE PLATE READER INSTALLATION PROCEDURES

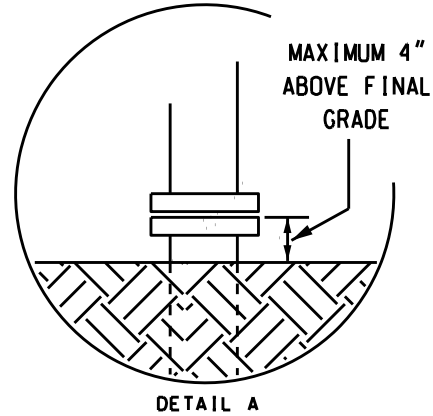

# FLOCK SAFETY BREAKAWAY LPR INSTALLATIONS

APPROVED PRODUCTS LIST FOR LICENSE PLATE READER INSTALLATIONS

MODOT PEDESTAL BASES

- AKRON FOUNDRY.....MODEL TS-1000-L-P
- AKRON FOUNDRY.....MODEL TS-1000-L-WP
- PELCO.....PB5336
- PELCO.....PB5337
- TRAFFIC PARTS.....TP289 X

MODOT FUSED SLIP CONNECTORS

- BUSSMANN.....HEB-JW-RYC

APPROVED ALTERNATE PEDESTAL BASES

- FREY MANUFACTURING.....CP6 SERIES

FLOCK SAFETY APPROVED LPR SUPPORTS  
*(WHICH STILL NEED TO BE INSTALLED BEHIND A BARRIER UNTIL CRASH TESTED BY OTHER LPR VENDORS)*

- PROVELI BREAKAWAY SYSTEM
- REDI-TORQUE BREAKAWAY SYSTEM

NOTE: ANY ALTERNATE POST DESIGNS MUST FIRST BE APPROVED THROUGH MoDOT'S MASH REVIEW PROCESS

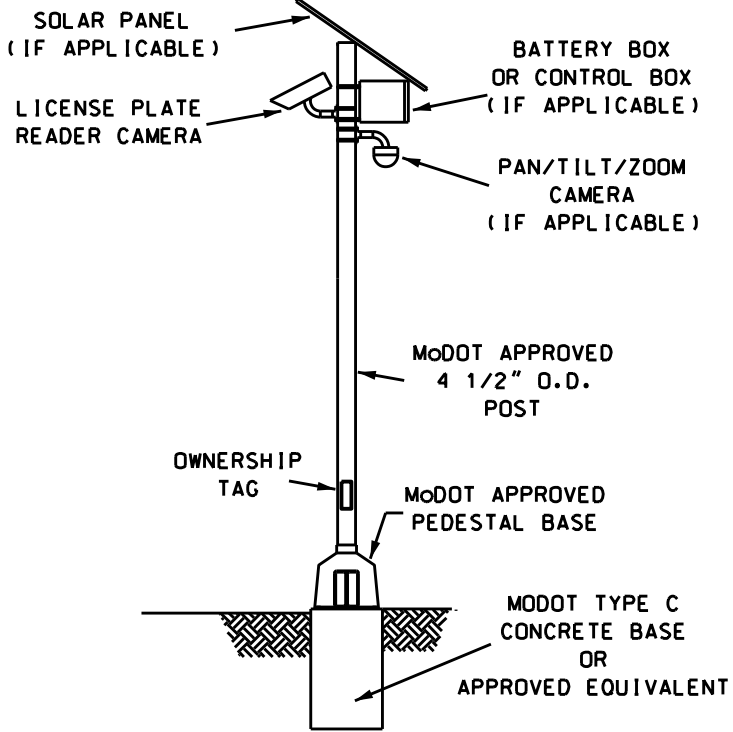

PERMISSIBLE INDEPENDENT LICENSE PLATE READER CONFIGURATION

GENERAL NOTES:

ONLY LICENSE PLATE READER CAMERAS, PAN-TILT-ZOOM CAMERAS, SOLAR PANELS AND/OR BATTERY/CONTROL BOXES MAY BE MOUNTED ON THE PEDESTAL POST. SEE PAGE 2 OF 2 FOR FURTHER DETAILS

OTHER HARDWARE COMPONENTS SHALL BE REMOTE LOCATED IN A PULL BOX ADJACENT TO THE POLE INSTALLATION OR AT THE RIGHT OF WAY LINE

THE OWNERSHIP TAG SHALL BE FABRICATED TO LAST THE LIFE OF THE INSTALLATION AND SHALL CONTAIN THE NAME AND CONTACT INFORMATION OF THE ENTITY RESPONSIBLE FOR MAINTAINING THE INSTALLATION

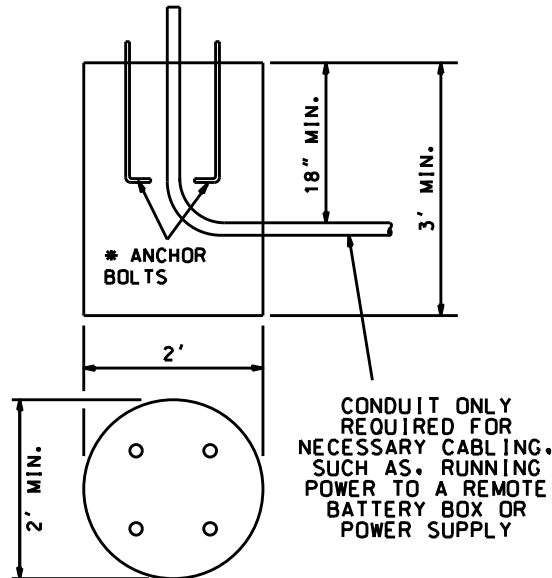
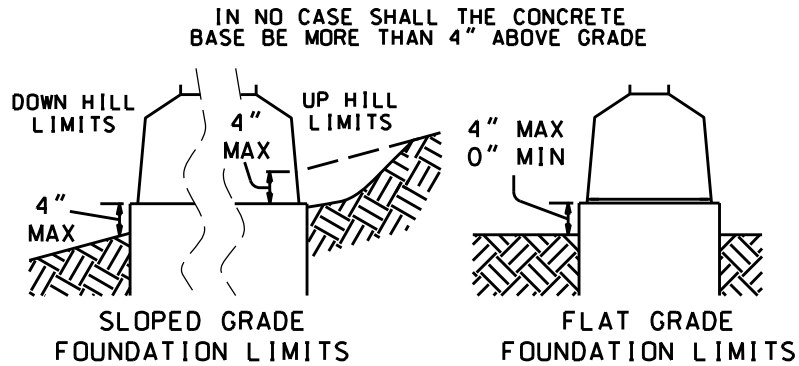

\* ANCHOR BOLT DIMENSIONS ARE SHOWN ON THE MANUFACTURER'S APPROVED DRAWINGS

TYPE C CONCRETE BASE

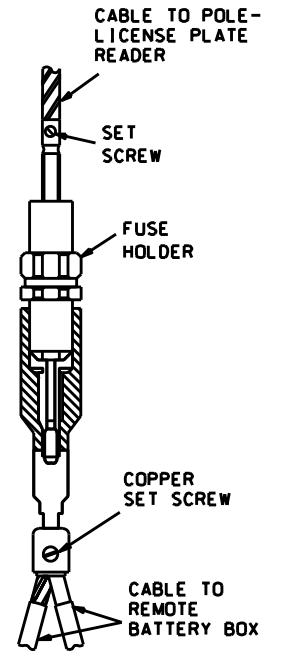

ALL CABLES ENTERING THE TRANSFORMER BASE THROUGH THE CONDUIT SHALL HAVE FUSED SLIP CONNECTORS LOCATED IN THE TRANSFORMER BASES

SINGLE OR DUAL CABLE FUSED SLIP CONNECTOR ASSEMBLY

 REVISION DATE: 11/25/2025

LICENSE PLATE READER INDEPENDENT INSTALLATION

PAGE 1 OF 2

THIS TYPICAL APPLICATION IS BASED ON MoDOT STANDARD PLANS

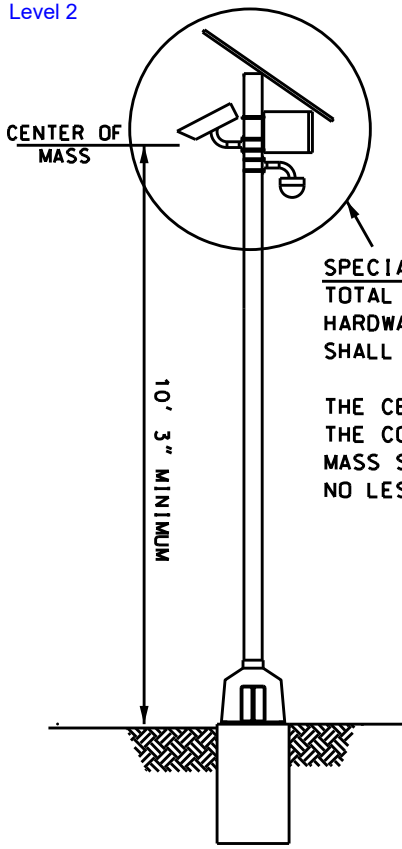

**SPECIAL NOTE FOR ALL CASES:**  
 TOTAL WEIGHT OF ALL  
 HARDWARE MOUNTED ON THE POLE  
 SHALL NOT EXCEED 120LBS

THE CENTER OF MASS OF  
 THE COMBINED HARDWARE  
 MASS SHALL BE  
 NO LESS THAN 10' 3"

**CURB AND GUTTER NOTE:**  
 ONLY AN ACCEPTABLE  
 BARRIER ON ROUTES  
 WITH POSTED SPEED  
 LIMITS 45 MPH OR LESS

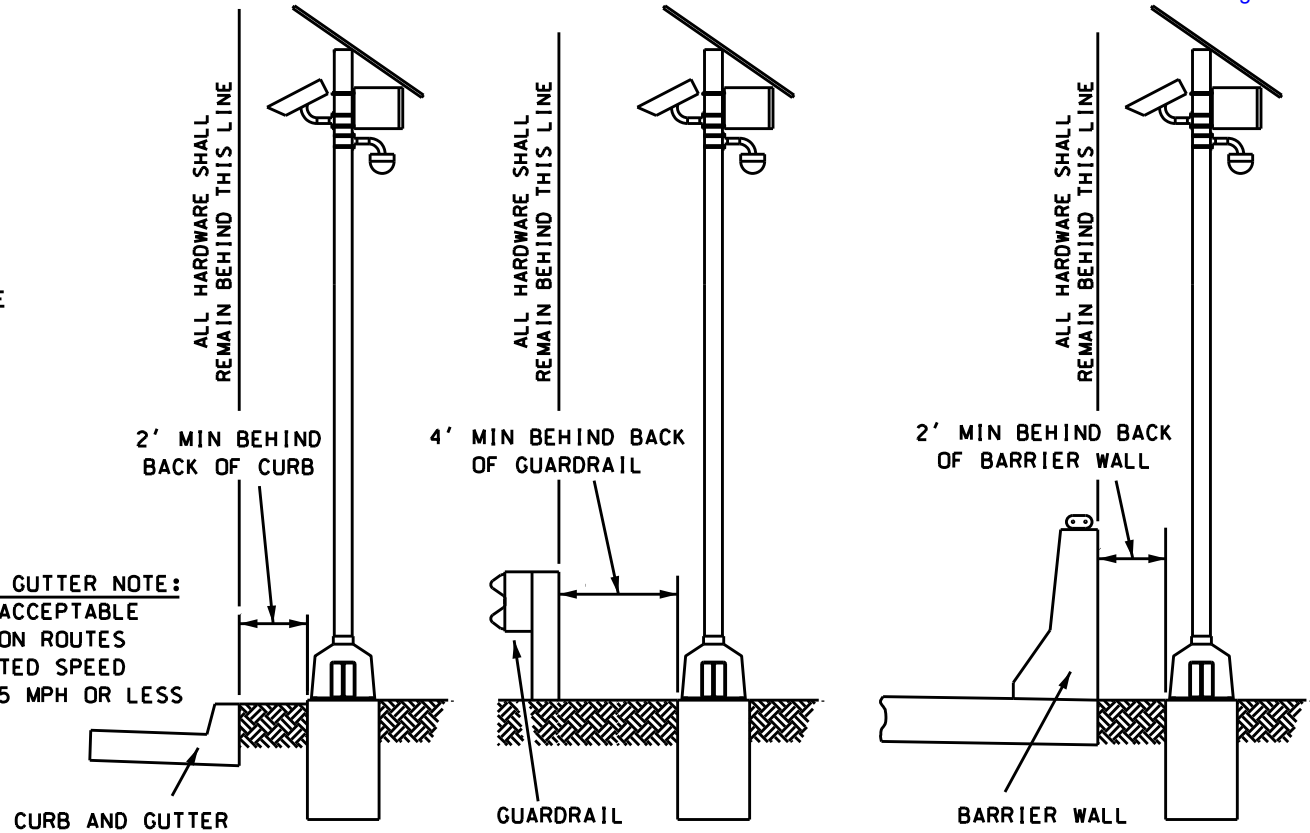

ACCEPTABLE EXISTING BARRIER INSTALLATIONS

**GENERAL NOTES:**

ALL INDEPENDENT LICENSE PLATE READERS SHALL  
 BE LOCATED BEHIND EXISTING BARRIER AS DEPICTED  
 ON THIS SHEET AND THE INSTALLATION SHALL BE A  
 MINIMUM OF 50 FEET FROM THE END OF THE BARRIER.  
 GUARD CABLE IS NOT DEPICTED AS AN OPTION DUE  
 TO ITS 12 FOOT DEFLECTION DISTANCE.

NON-INDEPENDENT INSTALLATIONS ARE LIMITED  
 TO EXISTING, NON-BREAKAWAY STRUCTURES ON,  
 OR ADJACENT TO, MODOT RIGHT OF WAY

SEE MODOT EPG SECTION 941.10 FOR COMPLETE  
 GUIDANCE ON LICENSE PLATE READER  
 INSTALLATIONS AND PROCEDURES

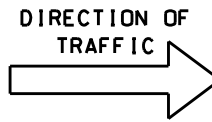

EDGE OF SHOULDER  
OR TRAVEL LANE

SIGNAL PEDESTAL  
BASE FOUNDATION

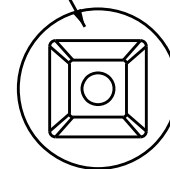

3-4 FEET

PRECAST  
PULL BOX

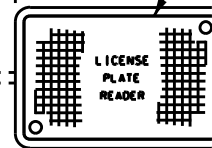

BATTERY / CONTROL BOX  
 PULL BOX INSTALLATION DETAIL

**PULL BOX NOTES:**

ITEMS NOT PERMITTED ON THE POLE  
 OR TOO HEAVY TO MOUNT ON THE  
 POLE SHALL BE EITHER MOUNTED  
 AT THE RIGHT OF WAY LINE  
 OR INSTALLED BELOW GRADE IN  
 A STANDARD MODOT PREFORMED  
 PULL BOX IN ACCORDANCE WITH  
 MODOT STANDARD PLAN 902.20

THE PULL BOX SHALL BE LOCATED  
 DOWNSTREAM OF THE POLE, PARALLEL  
 TO THE ROADWAY, LOCATED WITHIN  
 3-4 FEET OF THE POLE TO MINIMIZE  
 THE LENGTH OF BURIED CABLE

THE PULL BOX LID SHALL INDICATE  
 THE PURPOSE OF THE PULL BOX USING  
 A DURABLE LABELING SYSTEM

 REVISION DATE: 11/25/2025

LICENSE PLATE READER  
INDEPENDENT INSTALLATION

PAGE 2 OF 2

THIS TYPICAL APPLICATION IS BASED ON MODOT STANDARD PLANS