

TAP 9901(313)

City of St. Martins  
6909 West U.S. Business 50 West, St. Martins,  
Missouri 65109

# REQUEST FOR BID

BID OF

<MoDOT Vendor Number (if required)\_\_\_\_\_>

Bidder Name\_\_\_\_\_

Bidder Address\_\_\_\_\_

FOR  
CONSTRUCTING OR IMPROVING

**TAP 9901(313)**

**Grading, paving, and drainage to provide ADA compliant sidewalk from Business 50 West on Henwick Ln. to Carel Rd; and from Henwick Ln. to Business 50 West on Carel Rd. in St. Martins .  
Cole County**

**G16696**

**Resurfacing and pavement marking from just south of Business 50 West to Route T on Henwick Ln., Homsted Avenue from Henwick Ln. to the concrete section, from Henwick Ln. to Business 50 West on Carel Rd., and O'Rourke St. West of Carel Rd in St. Martins.  
Cole County**

**Required Combination**

**INVITATION TO BID**  
**Carel and Henwick Ln. Sidewalk Improvement**

Sealed bids for St Martins Carel to Henwick Lane sidewalk improvement & Resurfacing on Henwick Lane, Carel Rd. and O'Rourke street Paving, Project No. TAP-9901(523) and G16696, will be received at City of St Martins, City Clerk, 6909A Business 50 West St Martins, Missouri until 10 o'clock A.M. (Prevailing Local Time) on the **December 12, 2025**, bids will be publicly opened and read at 10:00 A.M.. Bids should be delivered to: City Clerk, City of St Martins, 6909A Business 50W, St Martins, MO, 65109.

The proposed work includes: TAP 9901(313) - Grading, paving, and drainage to provide ADA compliant sidewalk from Business 50 West on Henwick Ln. to Carel Rd; and from Henwick Ln. to Business 50 West on Carel Rd. in St. Martins .

and

G16696 - Resurfacing and pavement marking from just south of Business 50 West to Route T on Henwick Ln., Homsted Avenue from Henwick Ln. to the concrete section, from Henwick Ln. to Business 50 West on Carel Rd., and O'Rourke St. West of Carel Rd in St. Martins.

The projects listed above shall be bid in required combination. Combination bids will be in accordance with Sec. 102.12. By signing this bid, the bidder agrees to combine all projects in accordance with 102.12.1.

**Plans and specifications may be obtained from American Document Solutions on line plan room, at [www.adsplanroom.net](http://www.adsplanroom.net).**

A pre-bid conference will be held at 10:00 o'clock A.M on **December 3, 2025**, at the City of St. Martins, 6909A Business 50W, St Martins, Mo. 65109. All bidders are encouraged to attend the pre-bid meeting.

**All labor used in the construction of this public improvement shall be paid a wage no less than the prevailing hourly rate of wages of work of a similar character in this locality as established by the Department of Labor and Industrial Relations (Federal Wage Rate), or state wage rate, whichever is higher.**

The City of St. Martins hereby notifies all bidders that it will affirmatively ensure that in any contract entered into pursuant to this advertisement, businesses owned and controlled by socially and economically disadvantaged individuals will be afforded full opportunity to submit bids in response to this invitation and will not be discriminated against on the grounds of race, color, religion, creed, sex, age, ancestry, or national origin in consideration for an award.”

All bidders must be on MoDOT's Qualified Contractor List per Section 102.2 of the Missouri Standard Specifications for Highway Construction, 2011 Edition including all revisions. The contractor questionnaire must be on file 7 days prior to bid opening.

Contractors and sub-contractors who sign a contract to work on public works project provide a 10- Hour OSHA construction safety program, or similar program approved by the Department of Labor and Industrial Relations, to be completed by their on-site employees within sixty (60) days of beginning work on the construction project.

A certified or cashier's check or a bid bond in the amount of 5% shall be submitted with each proposal.

The project will be awarded to the lowest, responsive, responsible bidder. The City of St. Martins reserves the right to reject any or all bids.

**The DBE Goal for this project is 0%.**

No 2<sup>nd</sup> tier subcontracting will be allowed on this project.

Advertisement dates: 11/23/2025, 11/30/2025, 12/07/2025.

**BIDDER CHECKLIST**  
**FINAL CHECKLIST BEFORE SUBMITTING BID**

- 1. Submit completed Contractor Questionnaire and/or Contractor Prequalification Questionnaire with attachments not later than seven (7) days prior to the date and hour of the bid opening. See Secs 101-103 of the Standard Specifications, and Rule 7 CSR 10-15.900, "Prequalifications to Bid of Certain Contractors". Questionnaire and Contact information are provided [within this bid packet and shall be returned electronically to St. Martins City Clerk at stmartinsmo@gmail.com](#)
- 2. For submittal of paper bids, the complete set of bidding documents includes all information through the DBE forms (for DBE forms see #8). The Technical Specifications/Job Special Provisions are for the bidder's information only and is not to be returned with the bid.
- 3. If submitting the bid by mail, it is to be completed, executed, and submitted in a sealed envelope addressed to City of St. Martins. **Provide the vendor name, vendor address, vendor number, county, route and federal project number on the outside of the envelope.**
- 4. Please read all items in the bidding document carefully. For paper bids, complete all items in ink or by typing in the information.
- 5. Sign this bidding document properly. If submitted in the name of a firm or corporation, the legal name of the firm or corporation should appear in the space designated, and be signed for by one or more persons legally qualified to execute papers in the name of said firm or corporation. Affix Corporate Seal if the Bidder is a Corporation.
- 6. For paper bids submit a bid bond executed by bidder and surety, or attach cashier's check to the bid bond form.
- 7. Submit the Bidder's List Quote Summary form with the bid.
- 8. Submit the DBE Submittal Forms within 3 business days of the Bid Opening. The DBE Identification Submittal Form (Page 2 of this document) must be submitted for each DBE to be utilized on the project. Any DBE's submitted as regular dealers/distributors must have an accompanying [DBE Regular Dealer/Distributor Affirmation Form](#).
- 9. For paper bids, staple addenda to the bid in the appropriate part of the bid. The letter accompanying the addenda should be stapled to the inside of the back cover of the bid and returned. The bidder should retain a duplicate copy.

Below is a list of common mistakes made by bidders leading to non-responsive bids. Please refer to the Standard Specifications for the appropriate procedures for completing and submitting a bid.

- a) Not signing the bid
- b) Not incorporating the addendum into the bidding documents, including attaching the letter to the bid
- c) Not providing a bid bond
- d) Using pencil to fill out the bid
- e) Using white out to make corrections to the itemized bid sheets
- f) Not initialing changes made

All questions concerning the bid document preparation can be directed to the City of St. Martins, 6909 West U.S. Business 50 Highway St. Martins, Mo 65109 at (573) 694-2900. Project specific questions can be directed to Brian Williams at [BWilliams@ess-inc.com](mailto:BWilliams@ess-inc.com) or 573-636-3303 ext. 100.

**Special Needs:** If you have special needs addressed by the Americans with Disabilities Act, please notify the City of St. Martins, 6909 West U.S. Business 50 Highway St. Martins, Mo 65109, at (573) 694-2900 or through Missouri Relay System, TDD 1-800-735-2966, at least five (5) working days prior to the bid opening.

TABLE OF CONTENTS

Notice to Contractors

Proposed Work ..... (1)

Compliance With Contract Provisions ..... (2)

Period of Performance ..... (3)

Liquidated Damages ..... (4)

Bid Guaranty ..... (5)

Certifications for Federal Jobs ..... (6)

Antidiscrimination ..... (7)

Federal and State Inspection ..... (8)

Prevailing Wage ..... (9)

Worker Eligibility Requirements ..... (10)

OSHA Training Requirements ..... (11)

Buy America Requirements ..... (12)

Addendum Acknowledgement ..... (13)

Signature and Identity of Bidder ..... (14)

Trainees ..... (15)

Subcontractor Disclosure ..... (16)

Project Award ..... (17)

Materials Inspections ..... (18)

Prime Contractor Requirements ..... (19)

Tax Exempt Status ..... (20)

Acceptance of Provision for Price Adjustment for Fuel ..... (21a)>

Acceptance for Provision for Asphalt Cement Price Index ..... (21b)>

Itemized Bid Sheets

Bid Bond

Bidder’s List Quote Summary Form ([Fig. 136.9.12](#))

DBE Identification Submittal ([Fig. 136.9.9](#))

DBE Provisions ([Fig. 136.9.8](#))

General Provisions (Other Than MoDOT)

Job Special Provisions ([Sample JSP’s](#) on MoDOT’s Website)

Form FHWA 1273 ([Fig. 136.9.7](#))

Federal Aid Provisions

Applicable State Wage Rates

Applicable Federal Wage Rates

Applicable Environmental and Cultural Permits and Clearances

ADA Checklist ([Fig. 136.9.4](#))

G16696 Plans



## NOTICE TO CONTRACTORS

Sealed bids, addressed to City of St. Martins, 6909 West U.S. Business 50 Highway St. Martins, Mo 65109 for the proposed work will be received by the City of St. Martins until 10:00 am.. (prevailing local time) on **December 12, 2025** at the office of the City Hall located at 6909 West U.S. Business 50 Highway St. Martins, Mo 65109, bids will be publicly opened and read at 10:00 am. Bids should be delivered to: 6909 West U.S. Business 50 Highway St. Martins, Mo 65109.

(1) **PROPOSED WORK:** The proposed work, hereinafter called the work, includes:

The proposed work includes: TAP 9901(313) - Grading, paving, and drainage to provide ADA compliant sidewalk from Business 50 West on Henwick Ln. to Carel Rd; and from Henwick Ln. to Business 50 West on Carel Rd. in St. Martins .

and

G16696 - Resurfacing and pavement marking from just south of Business 50 West to Route T on Henwick Ln., Homestead Avenue from Henwick Ln. to the concrete section, from Henwick Ln. to Business 50 West on Carel Rd., and O'Rourke St. West of Carel Rd in St. Martins.

The projects listed above shall be bid in required combination. Combination bids will be in accordance with Sec. 102.12. By signing this bid, the bidder agrees to combine all projects in accordance with 102.12.1.

(2) **COMPLIANCE WITH CONTRACT PROVISIONS:** The bidder, having examined and being familiar with the local conditions affecting the work, and with the contract, contract documents, including the current version of the Missouri Highways and Transportation Commission's "Missouri Standard Specifications for Highway Construction," and "Missouri Standard Plans for Highway Construction" their revisions, and the request for bid, including appendices, the special provisions and plans, hereby proposes to furnish all labor, materials, equipment, services, etc., required for the performance and completion of the work. All references are to the Missouri Standard Specifications for Highway Construction, as revised, unless otherwise noted.

The following documents are available on the Missouri Department of Transportation web page at [www.modot.mo.gov](http://www.modot.mo.gov) under "Business with MoDOT" "Standards and Specifications". The effective version shall be determined by the letting date of the project.

General Provisions & Supplemental Specifications - October 2025

Supplemental Revisions to Missouri Standard Plans  
For Highway Construction - October 2025

These supplemental bidding documents contain all current revisions to the bound printed versions and have important legal consequences. It shall be conclusively presumed that they are in the bidder's possession, and they have been reviewed and used by the bidder in the preparation of any bid submitted on this project.

Please note that within the above-listed documents, the term "Commission" shall be replaced with the term, "City of St. Martins", and the term "Engineer" is a reference to the Engineer of Record from Engineering Surveys & Services

The contracting authority for this contract is City of St. Martin

(3) **PERIOD OF PERFORMANCE:** If the bid is accepted, the bidder agrees that work shall be diligently prosecuted at such rate and in such manner as, in the judgment of the engineer, is necessary for the completion of the work within the time specified as follows in accordance with Sec 108:

Calendar Days: \_\_\_\_\_  
Completion Date: **June 26, 2026**

(4) **LIQUIDATED DAMAGES:** The bidder agrees that, should the bidder fail to complete the work in the time specified or such additional time as may be allowed by the engineer under the contract, the amount of liquidated damages to be recovered in accordance with Sec 108 shall be as follows:

Liquidated damages per day \$ **2,300**  
December 2023

(5) **BID GUARANTY:** The bidder shall submit a Bid Guaranty meeting the requirements of Section 102 of the Missouri Standard Specifications for Highway Construction. A sample project bid bond form is included in the bid book. The bidder shall mark the box below to identify the type of Bid Guaranty.

- Paper Bid Bond  
 Cashier's Check

(6) **CERTIFICATIONS FOR FEDERAL JOBS:** By signing and submitting this bid, the bidder makes the certifications appearing in Sec. 102.18.1 (regarding affirmative action and equal opportunity), Sec. 102.18.2 (regarding disbarment, eligibility, indictments, convictions, or civil judgments), Sec. 102.18.3 (regarding anti-collusion), and Sec. 102.18.4 (regarding lobbying activities). Any necessary documentation is to accompany the bid submission, as required by these sections. As provided in Sec. 108.13, the contracting authority may terminate the contract for acts of misconduct, which includes but is not limited to fraud, dishonesty, and material misrepresentation or omission of fact within the bid submission.

(7) **ANTIDISCRIMINATION:** The Contracting Authority hereby notifies all bidders that it will affirmatively insure that in any contract entered into pursuant to this advertisement, businesses owned and controlled by socially and economically disadvantaged individuals will be afforded full opportunity to submit bids in response to this invitation and will not be discriminated against on the grounds of race, color, religion, creed, sex, age, ancestry, or national origin in consideration for an award.

(8) **FEDERAL AND STATE INSPECTION:** The Federal Government is participating in the cost of construction of this project. All applicable Federal laws, and the regulations made pursuant to such laws, shall be observed by the contractor, and the work will be subject to the inspection of the appropriate State or Federal Agency in the same manner as provided in Sec 105.10 of the Missouri Standard Specifications for Highway Construction with all revisions applicable to this bid and contract.

(9) **PREVAILING WAGE (FEDERAL AND STATE):** This contract requires payment of the prevailing hourly rate of wages for each craft or type of work required to execute the contract as determined by the Missouri Department of Labor and Industrial Relations, and requires adherence to a schedule of minimum wages as determined by the United States Department of Labor. For work performed anywhere on this project, the contractor and the contractor's subcontractors shall pay the higher of these two applicable wage rates. The applicable state wage rates for this contract are detailed in "Annual Wage Order No. 32", that is attached to this bidding document. The applicable federal wage rates for this contract are the effective Davis-Bacon federal wage rates posted the tenth day before the bid opening date and are attached herein.

These supplemental bidding documents have important legal consequences. It shall be conclusively presumed that they are in the bidder's possession, and they have been reviewed and used by the bidder in the preparation of any bid submitted on this project.

(10) **WORKER ELIGIBILITY REQUIREMENTS:** Execution of the construction contract for this project is dependent upon the awarded bidder providing an Affidavit of Compliance AND E-Verify Memorandum-of-Understanding (MOU) between the bidder and Department of Homeland Security to the Contracting Authority as required by section 285.530 RSMo. The cover page and signature page of the E-Verify MOU and the Affidavit must be submitted prior to award of this contract.

A sample Affidavit of Compliance can be found at the Missouri Attorney General's website at the following link:

[http://ago.mo.gov/forms/Affidavit\\_of\\_Compliance.pdf](http://ago.mo.gov/forms/Affidavit_of_Compliance.pdf)

All bidders must also be enrolled in the E-Verify Program, and include their MOU prior to contract execution. Bidders who are not enrolled will need to go to the following website link and select "Enroll in the Program" to get started. After completing the program, they will receive their E-Verify MOU with Department of Homeland Security. This document will need to be printed out and kept on file so that a copy can be attached to the Affidavit of Compliance.

[http://www.dhs.gov/files/programs/gc\\_1185221678150.shtm](http://www.dhs.gov/files/programs/gc_1185221678150.shtm)

This requirement also applies to subcontractors and contract labor, but this contract only requires submittal of the verification documents for the prime contractor. It is the prime contractor's responsibility to verify the worker eligibility of their subcontractors in order to protect their own company from liability as required by section 285.530 RSMo.

**(11) OSHA TEN HOUR TRAINING REQUIREMENTS:** Missouri Law, 292.675 RSMO, requires any awarded contractor and its subcontractor(s) to provide a ten-hour Occupational Safety and Health Administration (OSHA) Construction Safety Program (or a similar program approved by the Missouri Department of Labor and Industrial Relations as a qualified substitute) for their on-site employees (laborers, workmen, drivers, equipment operators, and craftsmen) who have not previously completed such a program and are directly engaged in actual construction of the improvement (or working at a nearby or adjacent facility used for construction of the improvement). The awarded contractor and its subcontractor(s) shall require all such employees to complete this ten-hour program, pursuant to 292.675 RSMO, unless they hold documentation on their prior completion of said program. Penalties, for Non-Compliance include contractor forfeiture to the Contracting Authority in the amount of \$2,500, plus \$100 per contractor and subcontractor employee for each calendar day such employee is employed beyond the elapsed time period for required program completion under 292.675 RSMO.

**(12) BUY AMERICA REQUIREMENTS:** Construction contracts shall assure compliance with Section 165 of the Surface Transportation Assistance Act of 1982, Section 337 of the Surface Transportation and Uniform Relocation Assistance Act of 1987, 23 CFR 635.410, and the Bipartisan Infrastructure Law (2021) Build America, Buy America Act Publication L. No. 117-58 regarding Buy America provisions on the procurement of foreign products and materials. On all contracts involving Federal-aid, all products of iron, steel, or a coating of steel which are incorporated into the work must have been manufactured in the United States. Construction materials consisting primarily of non-ferrous metals, plastic and polymer-based products, glass, lumber, or drywall also require Buy America certification. Cement and cementitious materials; aggregates such as stone, sand, or gravel; or aggregate binding agents or additives are excluded from this requirement. In addition, manufactured products are currently exempted under the 1983 waiver from FHWA. The Contracting Authority may allow minimal amounts of these materials from foreign sources, provided the cost does not exceed 0.1 percent of the contract sum or \$2,500, whichever is greater. The Contractor certifies that these materials are of domestic origin. Additional information regarding the "Buy America" requirements can be found at:

<https://www.fhwa.dot.gov/construction/cqit/buyam.cfm>

**(13) ADDENDUM ACKNOWLEDGEMENT:** The undersigned states that the all addenda (if applicable) have been received, acknowledged and incorporated into their bid, prior to submittal. For paper bids, staple addenda to the bid in the appropriate part of the bid.

**(14) SIGNATURE AND IDENTITY OF BIDDER:** The undersigned states that the following provided information is correct and that (if not signing with the intention to bind themselves to become the responsible and sole bidder) they are the agent of, and they are signing and executing this, as the bid of

\_\_\_\_\_, which is the correct LEGAL NAME as stated on the contractor questionnaire.

a) The organization submitting this bid is a(n) (1) individual bidder, (2) partnership, (3) joint venturer (whether individuals or corporations, and whether doing business under a fictitious name), or (4) corporation. Indicate by marking the appropriate box below.

- sole individual                       partnership                       joint venture
- corporation, incorporated under laws of state of \_\_\_\_\_.

b) If the bidder is doing business under a fictitious name, indicate below by filling in the fictitious name

\_\_\_\_\_

Executed by bidder this \_\_\_\_\_ day of \_\_\_\_\_ 20\_\_\_\_.

THE BIDDER CERTIFIES THAT THE BIDDER AND ITS OFFICIALS, AGENTS, AND EMPLOYEES HAVE NEITHER DIRECTLY NOR INDIRECTLY ENTERED INTO ANY AGREEMENT, PARTICIPATED IN ANY COLLUSION, OR OTHERWISE TAKEN ANY ACTION IN RESTRAINT OF FREE COMPETITIVE BIDDING IN CONNECTION WITH THIS BID,

AND THAT THE BIDDER INTENDS TO PERFORM THE WORK WITH ITS OWN BONAFIDE EMPLOYEES AND SUBCONTRACTORS, AND DID NOT BID FOR THE BENEFIT OF ANOTHER CONTRACTOR.

THE BIDDER ACKNOWLEDGES THAT THIS IS AN UNSWORN DECLARATION, EXECUTED UNDER PENALTY OF PERJURY UNDER THE LAWS OF THE UNITED STATES AND/OR FALSE DECLARATION UNDER THE LAWS OF MISSOURI, AND ANY OTHER APPLICABLE STATE OR FEDERAL LAWS. THE FAILURE TO PROVIDE THIS CERTIFICATION IN THIS BID MAY MAKE THIS BID NON-RESPONSIVE, AND CAUSE IT TO BE REJECTED.

THE BIDDER CERTIFIES THAT THE BIDDER'S COMPANY KNOWINGLY EMPLOYS ONLY INDIVIDUALS WHO ARE AUTHORIZED TO WORK IN THE UNITED STATES IN ACCORDANCE WITH APPLICABLE FEDERAL AND STATE LAWS AND ALL PROVISIONS OF MISSOURI EXECUTIVE ORDER NO. 07-13 FOR CONTRACTS WITH THE CONTRACTING AUTHORITY.

Check this box ONLY if the bidder REFUSES to make any or all of these certifications. The bidder may provide an explanation for the refusal(s) with this submittal.

\_\_\_\_\_  
Signature of Bidder's Owner, Officer, Partner or Authorized Agent

\_\_\_\_\_  
Please print or type name and title of person signing here

Attest:

\_\_\_\_\_  
Secretary of Corporation if Bidder is a Corporation

Affix Corporate Seal (If Bidder is a Corporation)

NOTE: If bidder is doing business under a fictitious name, the bid shall be executed in the legal name of the individual, partners, joint ventures, or corporation, and registration of fictitious name filed with the secretary of state, as required by sections 417.200 to 417.230 RSMo. If the bidder is a corporation not organized under the laws of Missouri, it shall procure a certificate of authority to do business in Missouri, as required by section 351.572 et seq RSMo. A certified copy of such registration of fictitious name or certificate of authority to do business in Missouri shall be filed with the Missouri Highways and Transportation Commission, as required by the standard specifications.

(15) **TRAINEES:** By submitting this bid, the bidder certifies that the bidder is familiar with the Training Provision in the Missouri Highways and Transportation Commission's "General Provisions and Supplement Specifications" which are available on the Missouri Department of Transportation web page at [www.modot.mo.gov](http://www.modot.mo.gov) under "Business with MoDOT" "Standards and Specifications". The number of trainee hours provided under this contract will be 0 slots at 1000 hours per slot or 0 hours.

(16) **SUBCONTRACTOR DISCLOSURE:** Requirements contained within Sec 102.7.8 of the Missouri Standard Specification for Highway Construction shall be waived for this contract.

(17) **PROJECT AWARD:** This project will be awarded to the lowest, responsive, responsible bidder.

(18) **MATERIALS INSPECTIONS:** All technicians who perform, or are required by the FHWA to witness, such sampling and testing shall be deemed as qualified by virtue of successfully completing the requirements of EPG 106.18 Technician Certification Program, for that specific technical area.

(19) **PRIME CONTRACTOR REQUIREMENTS:** The limitation in Sec 108.1.1 of the Missouri Standard Specifications for Highway Construction that "the contractor's organization shall perform work amounting to not less than 40 percent of the total contract cost" is waived for this contract. Instead, the less restrictive terms of the Federal Highway Administration's rule at Title 23 Code of Federal Regulations (CFR) § 635.116(a) shall apply, so that the contractor must perform project work with its own organization equal to and not less than 30 percent of the total original contract price. All other provisions in Sec 108.1.1 et seq. of the Missouri Standard Specifications for Highway Construction shall remain

in full force and effect, and shall continue to govern the contractor and its subcontractors, in accordance with the provisions of Title 23 CFR § 635.116.

**(20) SALES AND USE TAX EXEMPTION: City of St. Martins**, a tax exempt entity, will furnish a Missouri Project Exemption Certificate as described in Section 144.062 RSMo to the awarded contractor who in turn may use the certificate to purchase materials for a specific project performed for the tax exempt entity. Only the materials and supplies incorporated or consumed during the construction of the project are exempt. The certificate will be issued to the contractor for a specific project for a defined period of time.

**(21) (a) ACCEPTANCE OF PROVISION FOR PRICE ADJUSTMENT FOR FUEL:** Bidders have the option to accept the provision for Price Adjustment for Fuel in accordance with Sec. 109.14 . The bidder must mark the box below for those items of work in which they choose to accept the provision. No price adjustments will be made, due to fuel price changes, for bidders who do not accept this provision.

Excavation Production       Asphalt Production       Asphalt Hauling  
 Concrete Paving Production       Concrete Paving Hauling       Aggregate Base Hauling

**(b) ACCEPTANCE FOR PROVISION FOR ASPHALT CEMENT PRICE INDEX, SEAL COAT PRICE INDEX, UNDERSEAL PRICE INDEX OR UBAWS MEMBRANE PRICE INDEX:** Bidders have the option to accept the provision for Asphalt Cement Price Index, Seal Coat Price Index, Underseal Price Index and/or UBAWS Membrane Price Index in accordance with the General Provisions. The bidder must mark each box below if they choose to accept the provision. The Asphalt Cement Provision applies only to projects that have a quantity of asphalt wet ton mix pay items or converted square yard quantity over 1,000 tons, the Seal Coat Provision applies only to projects that have a quantity that exceeds 50,000 square yards, the Underseal Provision applies only to any projects that have a quantity that exceeds 10,000 gallons, and the UBAWS Membrane provision applies only to projects that have a quantity that exceeds 5,000 square yards. The above quantity limits apply to an individual project or any number of projects in the contract combination.

Asphalt Cement       Seal Coat       Underseal       UBAWS Membrane

**ITEMIZED BID:** The bidder should complete the following section in accordance with Sec 102.7. The bidder proposes to furnish all labor, materials, equipment, services, etc. required for the performance and completion of the work, as follows:

Line No.	Bid Item	Description	Unit	Quantity	Unit Bid Price	Extension
<b>ROADWAY ITEMS - 0100 - TAP 9901(313)</b>						
1	2013000	CLEARING AND GRUBBING	ACRE	0.1		
2	2022010	REMOVAL OF IMPROVEMENTS	L.S.	1		
3	2031000	CLASS A EXCAVATION	C.Y.	215		
4	2035500	EMBANKMENT IN PLACE	C.Y.	690		
5	2036000	COMPACTING EMBANKMENT	C.Y.	193		
6	2063000	CLASS 3 EXCAVATION	C.Y.	111		
7	3040143	TYPE 1 AGGREGATE FOR BASE (4 IN. THICK)	S.Y.	2502		
8	3101003	GRAVEL (A)	S.Y.	59		
9	4013000	BITUMINOUS PAVEMENT MIXTURE PG64-22 (BASE)	S.Y.	279		
10	6081010	CONCRETE CURB RAMP	S.Y.	31.2		
11	6081012	TRUNCATED DOMES	S.F.	60		
12	6086004	CONCRETE SIDEWALK, 4 IN.	S.Y.	1975.9		
13	6097000	ROCK LINING	C.Y.	4		
14	6141022	GRATE AND BEARING PLATE (3 FT. X 3 FT. OR 914 MM X 914 MM)	EACH	2		
15	6143020	CURB INLET	EACH	2		
16	6161005	CONSTRUCTION SIGNS	S.F.	352		
17	6161025	CHANNELIZER (TRIM LINE)	EACH	80		
18	6181000	MOBILIZATION	L.S.	1		
19	6274000	CONTRACTOR FURNISHED SURVEYING AND STAKING	L.S.	1		
20	7250324A	24 IN. CORRUGATED OR SPECIFIED EQUIVALENT SMOOTH INTERIOR PIPE GROUP B	L.F.	80.4		

Line No.	Bid Item	Description	Unit	Quantity	Unit Bid Price	Extension
21	7250330A	30 IN. CORRUGATED OR SPECIFIED EQUIVALENT SMOOTH INTERIOR PIPE GROUP B	L.F.	10.7		
22	7261012	12 IN. PIPE GROUP A	L.F.	46.4		
23	7261030	30 IN. PIPE GROUP A	L.F.	50.8		
24	7311033	PRECAST CONCRETE DROP INLET 3 FT X 3 FT	L.F.	7.4		
25	7311042	PRECAST CONCRETE DROP INLET 4 FT X 2 FT	L.F.	9.1		
26	7320030A	30 IN. (750 MM) OR ALLOWED SUBSTITUTE GROUP B FLARED END SECTION	EACH	1		
27	7320612A	12 IN. OR ALLOWED SUBSTITUTE GROUP A FLARED END SECTION	EACH	1		
28	7320630A	30 IN. OR ALLOWED SUBSTITUTE GROUP A FLARED END SECTION	EACH	2		
29	8051000A	SEEDING - COOL SEASON MIXTURES	ACRE	0.6		
30	6089905	PAVED APPROACH, 6 IN.	S.Y.	333.7		
31	6099901	SIDEWALK BRIDGE FLUME	L.S.	1		
32	6099903	CURB AND GUTTER (6 IN. BARRIER CURB)	L.F.	1260		
33	6099903	ROLL CURB & GUTTER AT RESIDENTIAL DRIVEWAY (INCLUDES CURB TRANSITION SECTIONS)	L.F.	225		
34	6089904	ADA METAL TRENCH COVER	S.F.	17.7		
35	7249903	4" PVC DRAIN PIPE	L.F.	106		
36	8069901	LAND DISTURBANCE COMPLIANCE	L.S.	1		
<b>SUBTOTAL</b>						
<b>SIGN ITEMS - 0200 - TAP 9901(313)</b>						
37	9031250A	U-CHANNEL POST, 3 LB	L.F.	12		
<b>SUBTOTAL</b>						

**PROJECT TOTAL:**



Line No.	Bid Item	Description	Unit	Quantity	Unit Price	Extension
<b>ROADWAY ITEMS - 001 - G16696</b>						
38	2152000A	SHAPING SLOPES, CLASS II	100FT	51		
39	3101003	GRAVEL (A)	S.Y.	311		
40	4011209	BITUMINOUS PAVEMENT MIXTURE PG64-22, (BP-1)	TON	1640		
41	4013010	BITUMINOUS PAVEMENT MIXTURE PG64-22 (BASE WIDENING)	TON	22		
42	4071005	TACK COAT	GAL	1330		
43	6139904	FURNISHING AND PLACING BITUMINOUS MATERIAL FOR PAVEMENT REPAIR	TON	188		
44	6139903	ASPHALT REMOVAL FOR PAVEMENT REPAIR	S.Y.	443		
45	6139903	SUBGRADE STABILIZATION 4" BASE - 12" THICK (PAVEMENT REPAIR)	S.Y.	441		
46	6161005	CONSTRUCTION SIGNS	S.F.	192		
47	6161025	CHANNELIZER (TRIM LINE)	EACH	10		
48	6181000	MOBILIZATION	L.S.	1		
49	6206001C	4 IN. YELLOW WATERBORNE PAVEMENT MARKING PAINT, TYPE P BEADS	L.F.	4660		
50	6221001	COLDMILLING BITUMINOUS PAVEMENT FOR REMOVAL OF SURFACING (3 IN. THICK OR LESS)	S.Y.	2615		
51	6223010	DIAMOND GRINDING (CONCRETE PAVEMENT)	S.Y.	720		
52	6224010	MODIFIED COLD MILLING (DEPTH TRANSITIONS)	S.Y.	730		
<b>SUBTOTAL:</b>						



ROADWAY - 002 - G16696 - COLE COUNTY						
53	4011209	BITUMINOUS PAVEMENT MIXTURE PG64-22, (BP-1)	TON	1424.1		
54	6206001C	4 IN. YELLOW WATERBORNE PAVEMENT MARKING PAINT, TYPE P BEADS	L.F.	10260		
55	6221001	COLDMILLING BITUMINOUS PAVEMENT FOR REMOVAL OF SURFACING (3 IN. THICK OR LESS)	S.Y.	169		
56	6224010	MODIFIED COLD MILLING (DEPTH TRANSITIONS)	S.Y.	278		
<b>SUBTOTAL:</b>						

**PROJECT TOTAL:**

**CONTRACT TOTAL:**

BID BOND

KNOW ALL PERSONS BY THESE PRESENTS, that we \_\_\_\_\_

as principal and \_\_\_\_\_  
as surety, are held and firmly bound unto the (Insert LPA Name) \_\_\_\_\_ in the penal sum  
of \_\_\_\_\_ Dollars (\$) to be paid to the commission to be credited to the state road fund, the  
principal and surety binding themselves, their heirs, executors, administrators, successors, and assigns, jointly and severally,  
firmly by these presents.

Sealed with our seals and dated this \_\_\_\_\_

THE CONDITION OF THIS OBLIGATION is such that

WHEREAS the principal is submitting herewith a bid to the commission on route(s) \_\_\_\_\_  
in \_\_\_\_\_ County(ies),  
project (s) \_\_\_\_\_  
for construction or improvement of state highway as set out in said bid;

NOW THEREFORE, if the commission shall accept the bid of the principal and if the principal shall properly  
execute and deliver to the commission the contract, contract bond, and evidence of insurance coverage in compliance with the  
requirements of the bid, the specifications, and the provisions of section 227.100 RSMo, to the satisfaction of the commission,  
then this obligation shall be void and of no effect, otherwise to remain in full force and effect.

In the event the said principal shall, in the judgment of the commission, fail to comply with any requirement as  
set forth in the preceding paragraph, then the state of Missouri, acting by and through the commission, shall immediately and  
forthwith be entitled to recover the full penal sum above set out, together with court costs, attorney's fees, and any other expense  
of recovery.

The principal and surety hereby certify that the document is the original or a verbatim copy of the bid bond form  
furnished by the Commission, in accordance with Sec 102.9 of the Missouri Standard Specifications for Highway Construction.

\_\_\_\_\_  
Principal

SEAL

By \_\_\_\_\_  
Signature

\_\_\_\_\_  
Surety

SEAL

By \_\_\_\_\_  
Signature of Attorney in Fact

NOTE: This bond must be executed by the principal, and by a corporate surety authorized to conduct surety business in the  
state of Missouri.



## DBE Submittal Forms - LPA

- (6) **DBE Submittal Forms:** This form must be submitted by 4 p.m. three (3) business days after bid opening. You may also use the Excel version located at:  
[https://epg.modot.org/forms/CM/DBE\\_Identification\\_Submittal\\_Form\\_LPA\\_Excel.xlsm](https://epg.modot.org/forms/CM/DBE_Identification_Submittal_Form_LPA_Excel.xlsm)

(A) **DBE Contract Goal:** By submitting this bid, the bidder certifies that the bidder is familiar with the DBE Program Requirements in this contract. The contract DBE goal for the amount of work to be awarded is **0%** of the total federal project price. The bidder shall also complete the DBE Submittal Form in accordance with the program requirements.

(B) **DBE Participation:** The bidder certifies that it will utilize DBE's as follows:

\_\_\_\_\_ % OF TOTAL FEDERAL CONTRACT

NOTE: Bidder must fill in the above blank. If no percentage is specified, the bidder certifies that it agrees to, and will comply with the contract goal. If a percentage below the contract goal is specified, then the bidder must submit complete documentation of good faith efforts to meet the DBE contract goal, immediately below.

(C) **Certification of Good Faith Efforts to Obtain DBE Participation:** By submitting its signed bid, the bidder certifies under penalty of perjury and other provisions of law, that the bidder took each of the following steps to try to obtain sufficient DBE participation to achieve the Commission's proposed DBE Contract Goal: (Attach additional sheets if necessary).

---

---

---

---

---

---

---

---

---

---

---

---

---

---

---

---

---

---

---

---

---

---

---

---

# DBE Identification Submittal Form

## (For Local Program Agency (LPA) Projects)

Job Number: \_\_\_\_\_

Route: \_\_\_\_\_

County: \_\_\_\_\_

Prime Contractor: \_\_\_\_\_

Contract Amount: \_\_\_\_\_

**Identification of Participating DBE's:** Provide the requested information below for each DBE participating on the project. Submit this information with your bid or no later than 4:00 p.m. on the 3<sup>rd</sup> business day after the bid opening. Contact MoDOT's Business Development and Compliance (BDC) Division at (573) 526-2978 for questions and assistance on completion. **This page of this document must be received for each DBE utilized on the project. A DBE Regular Dealer/Distributor Affirmation Form is required for each DBE firm submitted as a regular dealer or distributor.**

All information must be provided.

If awarded the contract for this project, the undersigned will use the following DBE to perform or furnish the work, supplies, and/or services as shown below:

DBE Name: \_\_\_\_\_ Address: \_\_\_\_\_

(A) Line No.	(B) Dollar Value of DBE Work** (Unit Price x Quantity of the Item in (A), or Lump Sum)	(C) Dollar value applicable to DBE Goal** (40%, 60%, 100%)	(D) Dollar amount applicable to DBE Goal (B x C)	(E) Percent of total contract amount for line item (D / total contract amount)
<b>DBE Total:</b>			<b>Total %</b>	

\*\*Cannot exceed contract amount for given item of work  
 Trucking services credited at 100% if the DBE owns the trucks or is leasing from a DBE firm  
 Allowed amount of participation will be in accordance with 49 CFR Part 26.  
 Supplier Affirmation Form required for all DBE firms submitted as suppliers.  
 Brokered services will only receive credit for fees.

Respectfully submitted:

\_\_\_\_\_  
 Company Name (Prime Contractor)

\_\_\_\_\_  
 Name / Title

\_\_\_\_\_  
 Signed (Prime Contractor)

**Instructions for Completing the  
DBE Identification Submittal Form  
(For Local Program Agency (LPA) Projects)  
(BDC-101)**

Submit this form with your bid or as outlined on front of page no later than 4:00 p.m. on the 3rd working day after the bid opening. Only DBE's listed in MoDOT's Missouri Regional Certification Committee (MRCC) directory may be used towards obtaining the DBE goal on the project. DBE firm must be certified with the appropriate North American Industrial Classification System (NAICS) code for the type of work being utilized to perform. The MRCC directory is available at the following link under the MRCC Directory tab: <https://www.modot.org/welcome-business-development-and-compliance>.

- (A) Insert Bid Line Item in the same order as it appears in the bid document.
- (B) Insert the result from multiplying the unit price for the bid line item by the quantities listed in column (A); a lump sum, if applicable, may also be inserted.
- (C) Insert the percentage of column (B) that the DBE will perform. If the DBE is a distributor as that term is defined in 49 CFR Part 26.55, then only 40% of the value in column (B) can be applied towards the contract specific goal. If the DBE is a supplier as that term is defined in 49 CFR Part 26.55, then only 60% of the value in column (B) can be applied towards the contract specific goal. **A [Supplier Affirmation Form](#) is required for each DBE firm submitted as a supplier. A copy of this form is provided on the next page.** If the DBE is furnishing and installing the line item, then 100% of the value can be applied.
- (D) Insert the result from dividing columns (B) and (C).
- (E) Insert the result from dividing column (D) from the total bid line item amount.



U.S. Department of  
Transportation

# DBE Regular Dealer/Distributor Affirmation Form

Bidder Name:

Contract Name/Number:

Sections 26.53(c)(1) of Title 49 Code of Federal Regulations requires recipients to make a preliminary counting determination for each DBE listed as a regular dealer or distributor to assess its eligibility for 60 or 40 percent credit, respectively, of the cost of materials and supplies based on its demonstrated capacity and intent to perform as a regular dealer or distributor, as defined in section 26.55(e)(2)(iv)(A),(B),(C), and (3) under the contract at issue. The regulation requires the recipient's preliminary determination to be made based on the DBE's written responses to relevant questions and its affirmation that its subsequent performance of a commercially useful function will be consistent with the preliminary counting of such participation. The U.S. Department of Transportation is providing this form as a tool for recipients, prime contractors, regular dealers, and distributors to use to carry out their respective responsibilities under this regulation. The form may be used by each DBE supplier whose participation is submitted by a bidder for regular dealer or distributor credit on a federally-assisted contract with a DBE participation goal. The form may also be used by prime contractors in connection with DBE regular dealer or distributor participation submitted after a contract has been awarded provided such participation is subject to the recipient's prior evaluation and approval. If this form is used, it should be accompanied by the bidder's commitment, contract, or purchase order showing the materials the DBE regular dealer or distributor is supplying. Use of this tool is not mandatory. If a recipient chooses a different method for complying with Section 26.53(c)(1), it must include that method in its DBE Program Plan.

DBE Name:	Total Subcontract/Purchase Order Amount: <input style="width: 90%; height: 20px;" type="text"/>
Authorized DBE Representative (Name and Title):	NAICS Code(s) Related to the Items to be Sold/Leased:

1. Will all items sold or leased be provided from the on-hand inventory at your establishment?  YES  NO  
(If "YES," you have indicated that your performance will satisfy the regular dealer requirements and may be counted at 60%. STOP here. Read and sign the affirmation below. If "NO" Continue.)
- a) Are you selling bulk items (e.g., petroleum products, steel, concrete, concrete products, sand, gravel, asphalt, etc.) or items not typically stocked due to their unique characteristics (aka specialty items)?  
 YES  NO (If "YES," Go to Question 2. If "NO" Continue.)
- b) Will at least 51% of the items you are selling be provided from the inventory maintained at your establishment, and will the minor quantities of items delivered from and by other sources be of the general character as those provided from your inventory?  
 YES  NO\* (If "YES," you have indicated that your performance will satisfy the regular dealer requirements and may be counted at 60%. STOP here. Read and sign the affirmation below.)

\*If 1., 1.a), and 1. b) above are "NO," your performance on the whole will not satisfy the regular dealer requirements; therefore, only the value of items to be sold or leased from inventory can be counted at 60%. (Go to Question 3. to determine if the items delivered from and by other sources are eligible for Distributor credit.)

2. Will you deliver all bulk or specialty items using distribution equipment you own (or under a long-term lease) and operate?  
 YES  NO<sup>1</sup>
- (If "YES," you have indicated that your performance will satisfy the requirements for a regular dealer of bulk items and may be counted at 60%. STOP here. Read and sign the affirmation below.)

<sup>1</sup> If "NO," your performance will not satisfy the requirements for a regular dealer of bulk items; the value of items to be sold or leased cannot be counted at 60%. (Go to Question 3.)

3. Will the written terms of your purchase order or bill of lading from a third party transfer responsibility, including risk for loss or damage, to your company at the point of origin (e.g. a manufacturer's facility)?  YES<sup>2</sup>  NO<sup>3</sup>
- a) Will you be using sources **other than** the manufacturer (or other seller) to deliver or arrange delivery of the items sold or leased?  YES<sup>2</sup>  NO<sup>3</sup>

<sup>2</sup> If your responses to 3 and 3.a) are "YES," you have indicated that your performance will satisfy the requirements of a distributor; therefore, the value of items sold or leased may be counted at 40%.

<sup>3</sup> If you responded "NO" to either 3 or 3.a), counting of your participation is limited to the reasonable cost of fees or commissions charged, including transportation charges for the delivery of materials or supplies; the cost of materials or supplies may not be counted.

I affirm that the information that I provided above is true and correct and that my company's subsequent performance of a commercially useful function will be consistent with the above responses. I further affirm that my company will independently negotiate price, order specified quantities, and pay for the items listed in the bidder's commitment. This includes my company's responsibility for the quality of such items in terms of necessary repairs, exchanges, or processing of any warranty claims for damaged or defective materials.

**Printed Name and Signature of DBE Owner/Authorized Representative:**

The bidder acknowledges its responsibility for verifying the information provided by the DBE named above and ensuring that the counting of the DBE's participation is accurate. Any shortfall caused by errors in counting are the responsibility of the bidder.

**Printed Name and Signature of Bidder's Authorized Representative:**

**DISADVANTAGED BUSINESS ENTERPRISE (DBE) PROGRAM REQUIREMENTS  
FOR LOCAL PROGRAMS**

**1.0 Program Applicability.** The subsequent sections will apply only to contracts involving U.S. Department of Transportation (USDOT) federal-aid or federal funded participation. Federal-aid or federal funded participation includes, but is not limited to, any funds directly or indirectly received by MoDOT, or authorized for distribution to or through MoDOT, by the USDOT or any operating administration within the USDOT. These provisions will not apply to contracts funded exclusively with state funds, or state and local funds. Any contractor, subcontractor, supplier, DBE firm, and contract surety involved in the performance of a federal-aid contract shall be aware of and fully understand the terms and conditions of the USDOT DBE Program, as the terms appear in Title 49 CFR Part 26 (as amended), the USDOT DBE Program regulations; Title 7 CSR Division 10, Chapter 8 (as amended), and the Commission's DBE Program rules.

**2.0 DBE Program Distinguished From Other Affirmative Action Programs.** The USDOT DBE Program established by the U.S. Congress is not the same as, and does not involve or utilize, any of the elements or authority of other state or local affirmative action programs, nor does the program rely upon state legislation or gubernatorial executive orders for implementation or authorization, other than the general authority given the Commission in Section 226.150, RSMo. The USDOT DBE Program is implemented by the Commission and MoDOT, through and in conjunction with the FHWA, FTA and FAA, as a "recipient" defined in Title 49 CFR 26.5.

**3.0 Policy Regarding DBE Firms.** It is the policy of the U. S. Department of Transportation and MoDOT that businesses owned by socially and economically disadvantaged individuals have an opportunity to participate in the performance of contracts funded in whole or in part with federal funds. Consequently, the requirements of 49 CFR Part 26 (as amended) and the Commission's implementing state regulations in Title 7 CSR Division 10, Chapter 8, "Disadvantaged Business Enterprise Program", will apply to any contract funded in whole or part with federal funds.

**4.0 Opportunity for DBEs to Participate.** Each contractor, subcontractor and supplier working on a contract funded in whole or in part with federal funds shall take all necessary and reasonable steps to ensure that DBEs have an opportunity to compete for and participate in performance on project contracts and subcontracts in which a DBE goal is established.

**5.0 Required Contract Provision.** The federal-aid contract will include the following provision, as mandated by USDOT at Title 49 CFR 26.13(b):

(a) The contractor, subrecipient or subcontractor shall not discriminate based on race, color, religion, national origin, or sex in the performance of the contract. The contractor shall carry out applicable requirements of 49 CFR Part 26 in the award and administration of USDOT-assisted contracts. Failure by the contractor to carry out these requirements is a material breach of the contract, which may result in the termination of the contract or such other remedy, as the recipient deems appropriate.



In this provision, “contractor” will be defined as the contractor on the contract; sub-contractor, or material supplier performing the work on or for the project. For the purposes of any federal-aid contract awarded by the Local Public Agency (LPA), they will be designated as “the recipient”. The contractor shall include this same contract provision in every supply contract or subcontract the contractor makes or executes.

**6.0 DBE Program Information.** DBE Program information may be obtained from the MoDOT Business Development & Compliance Division, 105 W. Capitol Avenue, P.O. Box 270, Jefferson City, Missouri 65102-0270. Phone (573) 751-7801, Fax (573) 526-0558, E-Mail: [dbe@modot.mo.gov](mailto:dbe@modot.mo.gov). It will be the duty of each contractor, and for the contractor’s subcontractors to take the steps necessary to determine the legal obligations and limitations under the DBE Program, as an element of responsibility. It will be the duty of each certified DBE firm to know, understand and comply with the DBE firm’s legal obligations and limitations under the DBE Program, as a requirement of program participation.

**7.0 DBE Certification, and the Missouri Unified Certification Program.** MoDOT and other certifying agencies within Missouri have partnered to form the Missouri Regional Certification Committee (MRCC) and developed a Unified Certification Program (UCP) pursuant to 49 CFR 26.81 and 7 CSR 10-8.061. Only DBE firms certified by the MRCC are eligible to perform work on a federal-aid contract for DBE contract goal credit. It is the contractor’s responsibility to ensure firms identified for participation are approved certified DBE firms.

The MRCC DBE Directory can be found at the following link: <https://www.modot.org/welcome-business-development-and-compliance>

**8.0 DBE Program-Related Certifications Made By Bidders and Contractors.** If the bidder makes a written, express disclaimer of one or more certifications or assurances in the bid, the bid will be considered non-responsive. By submitting a bid on any project involving USDOT federal financial participation, and by entering into any contract on the basis of that bid, the contractor makes each of the following DBE Program-related certifications and assurances to USDOT, to the Commission, to MoDOT, and to the LPA:

(a) The bidder certifies that management and bidding officers have reviewed and understand the bidding and project construction and administration obligations of the USDOT DBE Program regulations at Title 49 CFR Part 26 (as amended), and the Commission’s DBE Program rules at Title 7 CSR Division 10, Chapter 8 (as amended).

(b) The bidder agrees to ensure that certified DBE firms have a full and fair opportunity to participate in the performance of the contract financed in whole or in part with federal funds. The bidder certifies that all necessary and reasonable steps were taken to ensure that DBE firms have an opportunity to compete for, and perform work on the contract. The bidder further certifies that the bidder not discriminate on the basis of

race, color, age, national origin or gender in the performance of the contract, or in the award of any subcontract.

(c) The bidder certifies that if awarded the federal-aid contract, the contractor will make a good faith effort to utilize certified DBE firms committed to with the awarded contract.

(d) The bidder certifies, that if awarded the federal-aid contract with an approved DBE Good Faith Effort, the bidder will at a minimum achieve any DBE participation committed at time of bid as well as make good faith efforts to obtain additional DBE participation throughout the life of the project. Any liquidated damages at the completion of the project will be assessed contingent on the awarded bidders efforts in obtaining DBE participation.

(e) The bidder understands and agrees that if awarded the contract the contractor is legally responsible to ensure that the contractor and each DBE, comply fully with all regulatory and contractual requirements of the USDOT DBE Program, and that each DBE firm participating in the contract fully perform the designated tasks, with the DBE's own forces and equipment, under the DBE's own direct supervision and management. The bidder certifies, that if awarded the contract and if MoDOT or the Commission determine that the contractor, a DBE or any other firm retained by the contractor has failed to comply with the DBE Program requirements or federal or state DBE Program regulations, the Commission, through MoDOT, shall have the sole authority and discretion to determine the extent of the monetary value to which the DBE contract goals have not been met at the project completion, and to assess against and withhold monetary damages from the contractor up to the full amount of that breach. The bidder further understands and agrees that this clause authorizes the Commission, through MoDOT, to determine and fix the extent of the damages caused by a breach of any contractual or regulatory DBE Program requirement and that the damage assessment will be enforced in addition to, and not in lieu of, any other general liquidated damages clause in the contract. By submitting a bid for a federal-aid contract, the bidder irrevocably agrees to such an assessment of liquidated damages for DBE Program purposes, and authorizes the Commission and MoDOT to make such an assessment of liquidated damages against the contractor, and to collect that assessment from any sums due the contractor under the contract, or any other contract, or by other legal process. The bidder makes this certification, agreement and authorization on behalf of itself, for each federal-aid contract.

**9.0 Designation of DBE firms to perform on contract.** The bidder states and certifies that the DBE participation information submitted in the bid or within the contract designated time is true, correct and complete and that the information provided includes the names of all DBE firms that will participate in the contract, the specific line item (s) that each DBE firm will perform or partially perform, and the creditable dollar amounts of the participation of each DBE. The specific line item must reference the bid line number and item number contained in the proposal. The bidder further states and certifies that the bidder has committed to use each DBE firm listed for the work shown to

meet the DBE contract goal and that each DBE firm listed has clearly confirmed to the bidder that the DBE firm will participate in and perform the work, with the DBE's own forces.

(a) The bidder certifies the bidder's understanding that as the contractor on a contract funded in whole or in part by USDOT federal funds, the bidder may not unilaterally terminate, substitute for, or replace any DBE firm that was designated in the executed contract, in whole or in any part, with another DBE, any non-DBE firm or with the contractor's own forces or those of an affiliate, without the prior written consent of MoDOT. The bidder understands it must receive approval in writing from MoDOT for the termination of a DBE firm, or the substitution or replacement of a DBE before any substitute or replacement firm may begin work on the project in lieu of the DBE firm participation information listed in the executed contract. Unless MoDOT's written consent is provided as outlined above, the bidder shall not be entitled to any payment of work or material unless it is performed or supplied by the listed DBE.

(1) The bidder further certifies understanding, that if a DBE firm listed in the bid or approved in the executed contract documents ceases to be a certified DBE firm, at any time during the performance of the contract work, and a contract or subcontract with that firm has not yet been executed by the prime and subcontractor, the contractor can not count any work performed by that firm after the date of the firm's loss of eligibility toward meeting the DBE contract goal. The contractor can pursue efforts to replace the work planned with the decertified firm, with other certified DBEs, in coordination with MoDOT's Business Development & Compliance Division. If the contractor has executed a subcontract with the firm before the DBE lost eligibility and ceased to be a certified DBE, the contractor may continue to receive credit toward the DBE contract goal for that firm's work on the executed subcontract. However, if the reason for the firm's DBE decertification is due to the firm being acquired or merged with a non-DBE, the portion of the work remaining after the date of decertification is not eligible for counting towards the contract goal. In this case, the Contractor must seek additional DBE participation to the extent needed to meet the contract goal or demonstrate that it has made good faith efforts to do so. Subcontract extensions that add work for firms that become decertified from the DBE program may not count for DBE goal credit without MoDOT's prior written consent.

(2) The bidder further certifies the bidder's understanding, that the dollar value of any work completed by a DBE firm prior to approval of the DBE's substitution or replacement, in writing, by MoDOT will not be credited toward meeting the DBE contract goal. No credit toward the DBE goal will be given for any amount withheld from payment to the DBE or "back charged" against monies owed to the DBE, regardless of the purpose or asserted debt.

**10.0 Contract Goal Submittal.** The bidder may submit the completed "DBE Identification Submittal" information in the bid documents at the same time as, and within the sealed bid, at the time the bid is submitted. However, if that information is not completed and submitted with the initial sealed bid, then as a matter of responsiveness

and responsibility, all bidders shall file the completed “DBE Identification Submittal” pages to the Local Agency on or before 4:00 p.m. of the third business day after the bid opening date. The Local Agency may permit telefax transmittal.

Any “DBE Identification Submittal” that identifies a DBE regular dealer or distributor must be accompanied by a “DBE Regular Dealer/Distributor Affirmation Form” that is completed and signed by both the bidder and the DBE. This form must be received on or before 4:00 p.m. of the third business day after the bid opening date.

No extension of time will be allowed for any reason. The means of transmittal and the risk of timely receipt of the information shall be the bidder’s.

**10.1 Good Faith Effort Submittal.** If the bidder is not able to meet the Commission’s DBE contract goal, the bidder has the opportunity to submit with and as a part of the bid, a true, accurate, complete and detailed written explanation of good faith efforts taken to meet the DBE Contract Goal established in the bid documents. The bidder shall use the “DBE Identification Submittal” sheets for any DBE participation that will be committed towards the goal and an explanation, with any supporting documentation, for the inability to meet the full goal established on the contract. Any Good Faith efforts shall be submitted as part of the bid or within the three business days after the bid opening.

**10.2 Bidders Good Faith Efforts Described.** MoDOT will consider the quality, quantity, and intensity of the different kinds of efforts that the bidder has made based upon 49 CFR Appendix A to Part 26 and the following additional efforts:

- (a) Providing documentation on any and all past GFE activities for review.
- (b) Past project DBE performance utilization.
- (c) Race neutral methods utilized on completed projects.

All good faith efforts are evaluated on a case-by-case basis whereas any of the numerous good faith elements listed individually or collectively is not a guarantee of approval.

**10.3 Administrative Reconsideration of the Bidder’s Good Faith Efforts Made as a Part of the Bid Submittal.** If MoDOT determines that the apparent low bidder has failed to adequately document in the bid that the bidder made a good faith effort to achieve sufficient DBE participation in the contract work, that firm will be offered the opportunity for administrative reconsideration upon written request, before MoDOT and the Commission reject that bid as non-responsive.

**10.4 Forfeiture of Bid Bond possible when:** The failure of either the apparent low bidder to file the completed and executed “DBE Identification Submittal”, listing actual, committed DBE participation equal to or greater than the DBE contract goal percentage specified in the bid by 4:00 p.m. on the third business day after the bid opening, will be cause for rejection of that bid. In addition, the bid surety bond or bid guaranty of the apparent low bidder will be forfeited to and become the property of the Local Agency upon demand, only if the contract is awarded.

(a) By submitting a bid on a federal-aid project, the bidder accepts and agrees to these provisions, and the disposition of the bidders bid bond or guaranty, upon demand by the Local Agency.

**11.0 DBE Participation for Contract Goal Credit.** Goal credit will be in accordance with 49 CFR 26.55 as outlined for the following DBE types:

- Subcontractor
- Manufacturer
- Regular Dealer
- Distributor
- Broker
- Trucker

**12.0 DBE Required to Perform a Commercially Useful Function (CUF).** The DBE CUF requirements are stated in 49 CFR Part 26, (26.55). Any questions or further information needed for CUF determinations should be directed to MoDOT's Business Development & Compliance Division.

**12.1 Quality Control (QC) and Quality Assurance (QA) Reviews.** The prime contractor shall monitor their planned DBE project usage for CUF compliance and provide MoDOT information for areas of concern for further evaluation. MoDOT will perform a QA review, or compliance review, for DBE CUF and project documentation retained by the contractor through project completion. The contractor shall maintain all DBE related information it has received, documented and provided to MoDOT for a period of three years beyond the date of final inspection. MoDOT's determination that a DBE's participation may not count toward the project goal, or good faith effort level approved will be subject to administrative reconsideration.

**12.2 MoDOT Makes Final Determination On Whether a CUF Is Performed.** MoDOT will have the final authority to determine whether a DBE firm has performed a CUF on a federal-aid contract.

**13.0 Verification of DBE Participation at project completion.** (Assessment of Liquidated Damages Possible)

**13.1** Prior to final payment by the Local Agency, the contractor shall file with the Local Agency a detailed list showing each DBE used on the contract work, and the work performed by each DBE. The list shall show the actual dollar amount paid to each DBE for the creditable work on the contract, less any rebates, kickbacks, deductions, withholdings or other repayments made. The list shall be certified under penalty of perjury, or other law, to be accurate and complete. MoDOT and the Commission will use this certification and other information available to determine if the contractor and the contractor's DBEs satisfied the DBE contract goal percentage specified in the contract

and the extent to which the DBEs were fully paid for that work. The contractor shall acknowledge, by the act of filing the detailed list, that the information is supplied to obtain payment regarding a federal participation contract.

**13.2** Failure on the part of the contractor to achieve the DBE participation to which the contractor committed in the contract may result in liquidated damages being imposed on the contractor by the Commission for breach of contract and for non-compliance. If the contract was awarded with less than the original DBE contract goal proposed by the Commission, the revised lower amount became the final DBE contract goal, and that goal will be used to determine any liquidated damages to be assessed. Additionally, the Commission or MoDOT may impose any other administrative sanctions or remedies available at law or provided by the contract in the event of breach by the contractor by failing to satisfy the contractor's DBE contract goal commitment. The contractor will be offered the opportunity for administrative reconsideration of any assessment of liquidated damages determined at the project completion, upon written request. The administrative reconsideration officer may consider all facts presented, including the legitimacy or business reason for back charges assessed against a DBE firm, in determining the final amount of liquidated damages.

**14.0 Miscellaneous DBE Program Requirements.** In accordance with Title 49 CFR Part 26 and the Commission's DBE Program rules in Title 7 CSR Division 10, Chapter 8, the contractor, for both the contractor and for the contractor's subcontractors and suppliers, whether DBE firms or not, shall commit to comply fully with the auditing, record keeping, confidentiality, cooperation and anti-intimidation or retaliation provisions contained in those federal and state DBE Program regulations. By bidding on a federal-aid contract, and by accepting and executing that contract, the contractor agrees to assume these contractual obligations, and to bind the contractor's subrecipients contractually, at the contractor's expense.

**15.0 Bidders List Data Collection.** MoDOT is a recipient of federal funds and is required by 49 CFR 26.11, to provide data about its DBE program. The information shall consist of the names of all DBE and non-DBE subcontractors, suppliers, manufacturers, distributors, or brokers for actual use and of consideration by the prime bidder. Forms are provided to bidders that specify all required data points. Failure to submit the required forms may deem the bid irregular.

JOB SPECIAL PROVISIONS – TABLE OF CONTENTS

(Job Special Provisions shall prevail over Specification and/or General Provisions whenever in conflict therewith)

- A. Work Zone Traffic Management Plan
- B. Contract Liquidated Damages
- C. Project Contact for Contractor/Bidder Questions
- D. Emergency Provisions and Incident Management
- E. Utilities
- F. Supplemental Revisions
- G. ADA Compliance
- H. Lump Sum Land Disturbance Compliance
- I. Paved Approach, 6 IN.
- J. 6 IN. Barrier Curb and Gutter
- K. Roll Curb and Gutter at Residential Driveway
- L. 4 In. PVC Drain Pipe
- M. ADA Metal Trench Cover
- N. Sidewalk Bridge Flume
- O. Removal And Replacement of Landscaping Features

10/15/2025



*Kelly Lohsandt*

A. WORK ZONE TRAFFIC MANAGEMENT PLAN JSP-02-06A

**1.0 Description.** Work zone traffic management shall be in accordance with applicable portions of Division 100 and Division 600 of the Standard Specifications, and specifically as follows.

**2.0 Traffic Management Schedule.**

**2.1** Traffic management schedules shall be submitted to the engineer for review prior to the start of work and prior to any revisions to the traffic management schedule. The traffic management schedule shall include the proposed traffic control measures, hours traffic control will be in place, and work hours.

**2.2** The contractor shall notify the engineer prior to lane closures or shifting traffic onto detours.

**2.3** The engineer shall be notified as soon as practical of any postponement due to weather, material or other circumstances.

**2.4** In order to ensure minimal traffic interference, the contractor shall schedule lane closures for the absolute minimum amount of time required to complete the work. Lanes shall not be closed until material is available for continuous construction and the contractor is prepared to diligently pursue the work until the closed lane is opened to traffic.

**2.5 Traffic Congestion.** The contractor shall, upon approval of the engineer, take proactive measures to reduce traffic congestion in the work zone.

**2.5.1 Traffic Delay.** The contractor shall be responsible for maintaining the existing traffic flow through the job site during construction. If disruption of the traffic flow occurs and traffic is backed up in queues of 15-minute delays or longer, then the contractor shall review the construction operations which contributed directly to disruption of the traffic flow and make adjustments to the operations to prevent the queues from occurring again.

**2.5.2 Traffic Safety.**

**2.5.2.1** Where traffic queues routinely extend to within 1000 feet (300 m) of the ROAD WORK AHEAD, or similar, sign on a divided highway or to within 500 feet (150 m) of the ROAD WORK AHEAD, or similar, sign on an undivided highway, the contractor shall extend the advance warning area, as approved by the engineer.

**2.5.2.2** When a traffic queue extends to within 1000 feet (300 m) of the ROAD WORK AHEAD, or similar, sign on a divided highway or to within 500 feet (150 m) of the ROAD WORK AHEAD, or similar, sign on an undivided highway due to non-recurring congestion, the contractor shall deploy a means of providing advance warning of the traffic congestion, as approved by the engineer. The warning location shall be no less than 1000 feet (300 m) and no more than 0.5 mile (0.8 km) in advance of the end of the traffic queue on divided highways and no less than 500 feet (150 m) and no more than 0.5 mile (0.8 km) in advance of the end of the traffic queue on undivided highways.

**3.0 Work Hour Restrictions.**



**3.1** There are three major summer holiday periods: Memorial Day, Independence Day, and Labor Day. All lanes shall be scheduled to be open to traffic during these holiday periods, from 12:00 noon on the last working day preceding the holiday until 9:00 a.m. on the first working day subsequent to the holiday.

**B. CONTRACT LIQUIDATED DAMAGES JSP- 13-01D**

**1.0 Description.** Liquidated Damages for failure or delay in completing the work on time for this contract shall be in accordance with Sec 108.8. The liquidated damages include separate amounts for road user costs and contract administrative costs incurred by the Commission.

**2.0 Period of Performance.** Prosecution of work is expected to begin on the date specified below in accordance with Sec 108.2. Regardless of when the work is begun on this contract, all work on all projects shall be completed on or before the date specified below. Completion by this date shall be in accordance with the requirements of Sec 108.7.1.

Notice to Proceed: February 2, 2026  
Contract Completion Date: June 26, 2026

**3.0 Liquidated Damages for Contract Administrative Costs.** Should the contractor fail to complete the work on or before the contract completion date specified in Section 2.0, or within the number of calendar days specified in Section 2.1, whichever occurs first, the contractor will be charged contract administrative liquidated damages in accordance with Sec 108.8 in the amount of **\$2,300** per calendar day for each calendar day, or partial day thereof, that the work is not fully completed. For projects in combination, these damages will be charged in full for failure to complete one or more projects within the specified contract completion date or calendar days.

**4.0 Liquidated Damages for Road User Costs.** Should the contractor fail to complete the work on or before the contract completion date specified in Section 2.0, or within the number of calendar days specified in Section 2.1, whichever occurs first, the contractor will be charged road user costs in accordance with Sec 108.8 in the amount specified in Section 2.1 for each calendar day, or partial day thereof, that the work is not fully completed. These damages are in addition to the contract administrative damages and any other damages as specified elsewhere in this contract.

**C. PROJECT CONTACT FOR CONTRACTOR/BIDDER QUESTIONS**

All questions concerning this project during the bidding process shall be forwarded to the project contact listed below:

Brian Williams  
802 El Dorado Dr. Jefferson City, Mo 65101  
573-636-3303 Ext. 100  
BWilliams@ess-inc.com

**D. EMERGENCY PROVISIONS AND INCIDENT MANAGEMENT JSP-90-11**

**1.0** The contractor shall have communication equipment on the construction site or immediate access to other communication systems to request assistance from the police or other emergency agencies for incident management. In case of traffic accidents or the need for police to direct or restore traffic flow through the job site, the contractor shall notify police or other emergency agencies immediately as needed. The area engineer's office shall also be notified when the contractor requests emergency assistance.

*Scott Englund, City Administrator – 573-893-6465  
 Darrell Taube, Street Supervisor – 573-691-7658,  
 Brian Williams – Engineering Surveys & Services – 573-636-3303*

**2.0** In addition to the 911 emergency telephone number for ambulance, fire or police services, the following agencies may also be notified for accident or emergency situation within the project limits.

Missouri Highway Patrol (573-751-3313)	
City of St. Martins	City of Jefferson
(Fire: 573-636-8927	(Fire: 573-634-6401
Police: 573-634-2336)	Police: 573-634-6400)

**2.1** This list is not all inclusive. Notification of the need for wrecker or tow truck services will remain the responsibility of the appropriate police agency.

**2.2** The contractor shall notify enforcement and emergency agencies before the start of construction to request their cooperation and to provide coordination of services when emergencies arise during the construction at the project site. When the contractor completes this notification with enforcement and emergency agencies, a report shall be furnished to the engineer on the status of incident management.

**3.0** No direct pay will be made to the contractor to recover the cost of the communication equipment, labor, materials or time required to fulfill the above provisions.

**E. UTILITIES JSP-93-26C**

**1.0** For informational purposes only, the following is a list of names, addresses, and telephone numbers of the known utility companies in the area of the construction work for this improvement:

<u>Utility Name</u>	<u>Known Required Adjustment</u>
Cole County Water District No. 3 127 State Highway T Jefferson City, Missouri 65109 Telephone: 573-893-4262	No
Centurylink 415 Monroe Street Jefferson City, Missouri 65101	No

Telephone: 573-609-8514

Ameren Missouri  
101 Madison Street #100  
Jefferson City, Missouri 65101  
Telephone: 800-552-7583  
No

Three Rivers Electric Cooperative  
1324 East Main Street  
Linn, Missouri 65051  
Telephone: 573-644-9000  
No

Britespeed  
3546 N. Ten Mile Drive  
Jefferson City, MO 65101  
Contact: Tonjia Baldwin  
Telephone: 573-681-2503  
Yes

City of Jefferson – Sanitary Sewer  
320 East McCarty Street  
Jefferson City, Missouri 65101  
573-634-6410  
No

City of St. Martins – Storm Sewer  
6909 West Business Highway 50  
St. Martins, Missouri 65109  
573-896-6465  
No

**1.1** The existence and approximate location of utility facilities known to exist, as shown on the plans, are based upon the best information available to the Commission at this time. This information is provided by the Commission "as-is" and the Commission expressly disclaims any representation or warranty as to the completeness, accuracy, or suitability of the information for any use. Reliance upon this information is done at the risk and peril of the user, and the Commission shall not be liable for any damages that may arise from any error in the information. It is, therefore, the responsibility of the contractor to verify the above listing information indicating existence, location and status of any facility. Such verification includes direct contact with the listed utilities.

**1.2** The contractor agrees that any effects of the presence of the utilities, their relocation, contractor's coordination of work with the utilities and any delay in utility relocation shall not be compensable as a suspension of work, extra work, a change in the work, as a differing site condition or otherwise including but, without limitation, delay, impact, incidental or consequential damages. The contractor's sole remedy for the effects of the presence of utilities, delay in their relocation or any other effects shall be an excusable delay as provided in Section 105.7.3. The contractor waives, for itself, its subcontractors and suppliers the compensability of the presence of utilities, delay in their relocation and any cost to the contractor, its subcontractors and suppliers in any claim or action arising out of or in relation to the work under the contract.

**1.3** The contractor shall be solely responsible and liable for incidental and consequential damage to any utility facilities or interruption of the service caused by it or its subcontractors operation.

The contractor shall hold and save harmless the Commission from damages to any utility facilities interruption of service by it or it's subcontractor's operation.

**2.0** It shall be noted by the contractor that MoDOT is a member of Missouri One Call (800 Dig Rite). Some work on this project may be in the vicinity of MoDOT utility facilities, which includes but is not limited to traffic signal cables, highway lighting circuits, ITS cables, cathodic protection cables, etc. Prior to beginning work, the contractor shall request locates from Missouri One Call. The contractor shall also complete the Notice of Intent to Perform Work form located at the Missouri Department of Transportation website:

<http://www.modot.mo.gov/asp/intentToWork.shtml>

The contractor shall submit the form over the web (preferred method) or by fax to the numbers on the printed form. The notice must be submitted a minimum of 2 and a maximum of 10 working days prior to excavation just as Missouri One Call requires.

F. SUPPLEMENTAL REVISIONS

- Compliance with [2 CFR 200.216 – Prohibition on Certain Telecommunications and Video Surveillance Services or Equipment](#).

The Missouri Highways and Transportation Commission shall not enter into a contract (or extend or renew a contract) using federal funds to procure or obtain equipment, services, or systems that uses covered telecommunications equipment or services as substantial or as critical technology as part of any system where the video surveillance and telecommunications equipment was produced by Huawei Technologies Company, ZTE Corporation, Hytera Communications Corporation, Hangzhou Hikvision Digital Technology Company, or Dahua Technology Company (or any subsidiary or affiliate of such entities).

- **Delete Sec 106.9 in its entirety and substitute the following:**

**106.9 Buy America Requirements.**

Buy America Requirements are waived if the total amount of Federal financial assistance applied to the project, through awards or subawards, is below \$500,000.

**106.9.1 Buy America Requirements for Iron and Steel.**

On all federal-aid projects, the contractor's attention is directed to Title 23 CFR 635.410 *Buy America Requirements*. Where steel or iron products are to be permanently incorporated into the contract work, steel and iron material shall be manufactured, from the initial melting stage through the application of coatings, in the USA except for "minimal use" as described herein. Furthermore, any coating process of the steel or iron shall be performed in the USA. Under a general waiver from FHWA the use of pig iron and processed, pelletized, and reduced iron ore manufactured outside of the USA will be permitted in the domestic manufacturing process for steel or iron material.

**106.9.1.1 Buy America Requirements for Iron and Steel for Manufactured items.**

A manufactured item will be considered iron and steel if it is "predominantly" iron or steel. Predominantly iron or steel means that the cost of iron or steel content of a product is more than 50 percent of the total cost of all its components.

**106.9.2** Any sources other than the USA as defined will be considered foreign. The required domestic manufacturing process shall include formation of ingots and any subsequent process. Coatings shall include any surface finish that protects or adds value to the product.

**106.9.3** "Minimal use" of foreign steel, iron or coating processes will be permitted, provided the cost of such products does not exceed 1/10 of one percent (0.1 percent) of the total contract cost or \$2,500.00, whichever is greater. If foreign steel, iron, or coating processes are used, invoices to document the cost of the foreign portion, as delivered to the project, shall be provided and the engineer's written approval obtained prior to placing the material in any work.

**106.9.4** Buy America requirements include a step certification for all fabrication processes of all steel or iron materials that are accepted per Sec 1000. The AASHTO Product Evaluation and Audit Solutions compliance program verifies that all steel and iron products fabrication processes conform to 23 CFR 635.410 Buy America Requirements and is an acceptable standard per 23 CFR 635.410(d). AASHTO Product Evaluation and Audit Solutions compliant suppliers will not be required to submit step certification documentation with the shipment for some selected steel and iron materials. The AASHTO Product Evaluation and Audit Solutions compliant supplier shall maintain the step certification documentation on file and shall provide this documentation to the engineer upon request.

**106.9.4.1** Items designated as Category 1 will consist of steel girders, piling, and reinforcing steel installed on site. Category 1 items require supporting documentation prior to incorporation into the project showing all steps of manufacturing, including coating, as being completed in the United States and in accordance with CFR Title 23 Section 635.410 Buy America Requirements. This includes the Mill Test Report from the original producing steel mill and certifications documenting the manufacturing process for all subsequent fabrication, including coatings. The certification shall include language that certifies the following. That all steel and iron materials permanently incorporated in this project was procured and processed domestically and all manufacturing processes, including coating, as being completed in the United States and in accordance with CFR Title 23 Section 635.410.

**106.9.4.2** Items designated as Category 2 will include all other steel or iron products not in Category 1 and permanently incorporated in the project. Category 2 items shall consist of, but not be limited to items such as fencing, guardrail, signing, lighting and signal supports. The prime contractor is required to submit a material of origin form certification prior to incorporation into the project from the fabricator for each item that the product is domestic. The Certificate of Materials Origin form ([link to certificate form](#)) from the fabricator must show all steps of manufacturing, including coating, as being completed in the United States and in accordance with CFR Title 23 Section 635.410 Buy America Requirements and be signed by a fabricator representative. The engineer reserves the right to request additional information and documentation to verify that all Buy America requirements have been satisfied. These documents shall be submitted upon request by the engineer and retained for a period of 3 years after the last reimbursement of the material.

**106.9.4.3** Any minor miscellaneous steel or iron items that are not included in the materials specifications shall be certified by the prime contractor as being procured domestically. Examples of these items would be bolts for sign posts, anchorage inserts, etc. The certification shall read "I certify that all steel and iron materials permanently incorporated in this project during all manufacturing processes, including coating, as being completed in the United States

and in accordance with CFR Title 23 Section 635.410 Buy America Requirements procured and processed domestically in accordance with CFR Title 23 Section 635.410 Buy America Requirements. Any foreign steel used was submitted and accepted under minor usage". The certification shall be signed by an authorized representative of the prime contractor.

**106.9.5** When permitted in the contract, alternate bids may be submitted for foreign steel and iron products. The award of the contract when alternate bids are permitted will be based on the lowest total bid of the contract based on furnishing domestic steel or iron products or 125 percent of the lowest total bid based on furnishing foreign steel or iron products. If foreign steel or iron products are awarded in the contract, domestic steel or iron products may be used; however, payment will be at the contract unit price for foreign steel or iron products.

**106.9.6 Buy America Requirements for Construction Materials other than iron and steel materials.** Construction materials means articles, materials, or supplies that consist of only one of the items listed. Minor additions of articles, materials, supplies, or binding agents to a construction material do not change the categorization of the construction material. Upon request by the engineer, the contractor shall submit a domestic certification for all construction materials listed that are incorporated into the project.

- (a) Non-ferrous metals
- (b) Plastic and Polymer-based products (including polyvinylchloride, composite building materials, and polymers used in fiber optic cables)
- (c) Glass (including optic glass)
- (d) Fiber optic cable (including drop cable)
- (e) Optical fiber
- (f) Lumber
- (g) Engineered wood
- (h) Drywall

**106.9.6.1 Minimal Use allowance for Construction Materials other than iron or steel.**

"The total value of the non-compliant products is no more than the lesser of \$1,000,000 or 5% of total applicable costs for the project." The contractor shall submit to the engineer any non-domestic materials and their total material cost to the engineer. The contractor and the engineer will both track these totals to assure that the minimal usage allowance is not exceeded.

**106.9.7 Buy America Requirements for Manufactured Products.**

Manufactured products means:

- (a) Articles, materials, or supplies that have been:
  - (i) Processed into a specific form and shape; or
  - (ii) Combined with other articles, materials, or supplies to create a product with different properties than the individual articles, materials, or supplies.
- (b) If an item is classified as an iron or steel product, a construction material, or a section 70917(c) material under § 184.4(e) and the definitions set forth in this section, then it is not a manufactured product. However, an article, material, or supply classified as a manufactured product under § 184.4(e) and paragraph (1) of this definition may include components that are construction materials, iron or steel products, or section 70917(c) materials.

**106.9.7.1** Manufactured products are exempt from Buy America requirements. To qualify as a manufactured product, items that consist of two or more of the listed construction materials that have been combined together through a manufacturing process, and items that include at least one of the listed materials combined with a material that is not listed through a manufacturing process, should be treated as manufactured products, rather than as construction materials.

**106.9.7.2** Manufactured items are covered under a general waiver to exclude them from Buy America Requirements. To qualify for the exemption the components must comprise of 55% of the value of materials in the item. The final assembly must also be performed domestically.

- **Third-Party Test Waiver for Concrete Aggregate**

**1.0 Description.** Third party tests may be allowed for determining the durability factor for concrete pavement and concrete masonry aggregate.

**2.0 Material.** All aggregate for concrete shall be in accordance with Sec 1005.

**2.1** MoDOT personnel shall be present at the time of sampling at the quarry. The aggregate sample shall be placed in an approved tamper-evident container (provided by the quarry) for shipment to the third-party testing facility.

**2.2** AASHTO T 161 Method B Resistance of Concrete to Rapid Freezing and Thawing, shall be used to determine the aggregate durability factor. All concrete beams for testing shall be 3-inch wide by 4-inch deep by 16-inch long or 3.5-inch wide by 4.5-inch deep by 16-inch long. All beams for testing shall receive a 35-day wet cure fully immersed in saturated lime water prior to initiating the testing process.

**2.3** Concrete test beams shall be made using a MoDOT approved concrete pavement mix design.

**3.0 Testing Facility Requirements.** All third-party test facilities shall meet the requirements outlined in this provision.

**3.1** The testing facility shall be AASHTO accredited.

**3.1.1** For tests ran after January 1, 2025, accreditation documentation shall be on file with the Construction and Materials Division prior to any tests being performed.

**3.1.2** Construction and Materials Division may consider tests completed prior to January 1, 2025, to be acceptable if all sections of this provision are met, with the exception of 3.1.1. Accreditation documentation shall be provided with the test results for tests completed prior to January 1, 2025. No tests completed prior to September 1, 2024, will be accepted.

**3.2** The testing facility shall provide their testing process, list of equipment, equipment calibration documentation, and testing certifications or qualifications of technicians performing the AASHTO T 161 Procedure B tests. The testing facility shall provide details on their freezing and thawing apparatus including the time and temperature profile of their freeze-thaw chamber. The profile shall include the temperature set points throughout the entirety of the freeze-thaw

cycle. The profile shall show the cycle time at which the apparatus drains/fills with water and the cycle time at which the apparatus begins cooling the specimens.

**3.3** Results, no more than five years old, from the third-party test facility shall compare within  $\pm 2.0$  percent of an independent test from another AASHTO accredited test facility or with MoDOT test records, in order to be approved for use (e.g. test facility results in a durability factor of 79, MoDOT's recent durability test factor is 81; this compared within +2 percent). The independent testing facility shall be in accordance with this provision. The comparison test can be from a different sample of the same ledge combination.

**3.4** When there is a dispute between the third party durability test results and MoDOT durability test results, the MoDOT durability test result shall govern.

**3.5** Test results shall be submitted to MoDOT's Construction and Materials division electronically for final approval. Test results shall include raw data for all measurements of relative dynamic modulus of elasticity and percent length change for each individual concrete specimen. Raw data shall include initial measurements made at zero cycles and every subsequent measurement of concrete specimens. Raw data shall include the cycle count and date each measurement was taken. Test results shall also include properties of the concrete mixture as required by AASHTO T 161. This shall include the gradation of the coarse aggregate sample. If AASHTO T 152 is used to measure fresh air content, then the aggregate correction factor for the mix determined in accordance with AASHTO T 152 shall also be included.

**4.0 Method of Measurement.** There is no method of measurement for this provision. The testing requirements and number of specimens shall be in accordance with AASHTO T 161 Procedure B.

**5.0 Basis of Payment.** No direct payment will be made to the contractor or quarry to recover the cost of aggregate samples, sample shipments, testing equipment, labor to prepare samples or test samples, or developing the durability report.

- **Delete paragraph 15.0 of the General Provision Disadvantaged Business Enterprise (DBE) Program Requirements and substitute the following:**

**15.0 Bidder's List Quote Summary.** MoDOT is a recipient of federal funds and is required by 49 CFR 26.11 to provide data about its DBE program. All bidders who seek to work on federally assisted contracts must submit data about all DBE and non-DBEs in accordance with Sec 102.7.9. MoDOT will not compare the submitted Bidder's List Quote Summary to any other documents or submittals, pre or post award. All information will be used by MoDOT in accordance with 49 CFR 26.11 for reporting to USDOT and to aid in overall DBE goal setting.

- **Add Sec 102.7.9 to include the following:**

**102.7.9 Bidder's List Quote Summary.** Each bidder shall submit with each bid a summary of all subcontractors, material suppliers, and service providers (e.g. hauling) considered on federally funded projects pursuant to 49 CFR 26.11. The bidder will provide the firm's name, the corresponding North American Industry Classification System (NAICS) code(s) the firm(s)



were considered for, and whether or not they were used in the bid. The information submitted should be the most complete information available at the time of bid. The information shall be disclosed on the Bidder's List Quote Summary form provided in the bidding documents and submitted in accordance with Sec 102.10. Failure to disclose this information may result in a bid being declared irregular.

- **Delete Sec 102.1 - 102.2.5 and substitute the following:**

**102.1 Notice of Bid Opening.** After the date is fixed for the receipt of bids, the notice of bid opening will be posted on MoDOT's website and published as required by law. The notice of bid opening will contain a description of the proposed work, instructions and information to the potential bidder regarding bid forms, plans, specifications, combination bids and the reservation of the right of the Commission to reject any and all bids.

**102.2 Contractor Questionnaire.** Each prospective bidder, including a joint venture, shall file a contractor questionnaire on the form furnished by the Commission, which is available on MoDOT's website. The contractor questionnaire shall be furnished to the Commission as a separate document apart from any other document submitted. A bid will not be opened and read unless a fully responsive contractor questionnaire is on file with the Commission at least seven days prior to the time set for the opening of the bids. A new contractor questionnaire shall be filed as described in **Title 7 CSR 10-15.010**, except the Commission reserves the right to request a contractor questionnaire from any contractor as of any date if the Commission has shown reason to believe that the contractor's experience data may have changed from that shown on the questionnaire on file. This document shall include a record of the bidder's experience data. The Commission will use this information as an aid to determine in each instance the lowest responsible bidder and nothing contained herein shall be construed as depriving the Commission of the Commission's discretion in the matter of determining the lowest responsible bidder.

**102.2.1** At any time prior to award, as a condition of award and for a period of three years after the date of final acceptance, the Commission may request true copies of the bidder's financial data, including the bidder's balance sheet, profit and loss statement and similar financial data, as of the close of the bidder's most recent fiscal year prior to submission of the bid, and for each fiscal year between the contract award and final acceptance of the contract work. Unless specified otherwise by the Commission, financial data shall be prepared by an accountant and audited financial data shall be provided if it is available to the bidder for the fiscal period requested. A bidder who has not closed the first fiscal year prior to the date of the request shall supply the last periodic balance sheet, profit and loss statement and similar data.

**102.2.2** Each prospective bidder shall sign the contractor questionnaire acknowledging that such bidder will fully comply with all written requests by the Missouri Department of Labor and Industrial Relations, Division of Labor Standards, to provide information for the purpose of establishing a prevailing wage.

**102.2.3** The prospective bidder doing business in the State of Missouri shall submit the charter number with the contractor questionnaire. The entity must be in good standing on file with the Corporation Division of the Missouri Secretary of State's Office to be approved and successfully awarded a bid. Each corporation that is a party to a joint venture shall submit the same required report with the corporation's joint venture contractor questionnaire.

**102.2.4** All prospective bidders who are corporations organized in states other than Missouri or countries other than the USA shall furnish, at the prospective bidder's cost, a certified copy of a current certificate of authority to do business in Missouri, with said certificate to remain on file with the Commission. Such a certified copy may be secured from the corporation supervisor in the Office of the Secretary of State, Jefferson City, Missouri. The prospective bidder agrees to cause the prospective bidder's authority to do business as a foreign corporation to be continued and extended throughout the life of any contract awarded and until all claims thereon and thereunder shall have been finally settled. All prospective bidders shall have a valid certificate of authority to transact business in Missouri at the time of bid opening as a condition of responsiveness.

- **Delete Sec 108.13.1 and substitute the following:**

**108.13.1** The acts, omissions and liabilities of persons or firms affiliated with the contractor or of persons that are principals of the contractor, are those of the contractor, unless the circumstances clearly negate that conclusion. Persons or firms are "affiliates" of each other if, directly or indirectly, either one controls or has the power to control the other or a third person controls or has the power to control both. Examples of control include, but are not limited to: interlocking management or ownership, identity of interests among family members, shared facilities and equipment, common use of employees on projects or a new business entity organized following the determination of ineligibility or non-responsibility of a person or firm which has the same or similar management, ownership or principal employees as the ineligible person. A "principal" will be defined as an officer, director, owner, partner or other natural person within a firm with primary management, supervisory or contracting responsibilities, including participating in, or formulating, bids.

**G. AMERICANS WITH DISABILITIES ACT (ADA) COMPLIANCE AND FINAL ACCEPTANCE OF CONSTRUCTED FACILITIES JSP-10-01A**

**1.0 Description.** The contractor shall comply with all laws pertaining to the Americans with Disabilities Act (ADA) during construction of pedestrian facilities on public rights of way for this project. An ADA Checklist is provided herein to be utilized by the contractor for verifying compliance with the ADA law. The contractor is expected to familiarize himself with the plans involving pedestrian facilities and the ADA Post Construction Checklist prior to performing the work.

**2.0 ADA Checklist.** The contractor can locate the ADA Checklist form on the Missouri Department of Transportation website:

[http://www.modot.mo.gov/business/contractor\\_resources/forms.htm](http://www.modot.mo.gov/business/contractor_resources/forms.htm)

**2.1** The ADA Checklist is intended to be a helpful tool for the contractor to use during the construction of the pedestrian facilities and a basis for the commission's acceptance of work. Prior to work being performed, the contractor shall bring to the engineer's attention any planned work that is in conflict with the design or with the requirement shown in the checklist. Situations may arise where the checklist may not fully address all requirements needed to construct a facility to the full requirements of current ADA law. In those situations, the contractor shall propose a solution to the engineer that is compliant with current ADA law using the following hierarchy of

resources: 2010 ADA Standards for Accessible Design, Draft Public Rights of Way Accessibility Guidelines (PROWAG) dated November 23, 2005, MoDOT's Engineering Policy Guidelines (EPG), or a solution approved by the U.S. Access Board.

**2.2** It is encouraged that the contractor monitor the completed sections of the newly constructed pedestrian facilities in attempts to minimize negative impacts that his equipment, subcontractors or general public may have on the work. Completed facilities must comply with the requirements of ADA and the ADA Checklist or have documented reasons for the non-complaint items to remain.

### **3.0 Coordination of Construction.**

**3.1** Prior to construction and/or closure on an existing pedestrian path of travel, the contractor shall submit a schedule of work to be constructed, which includes location of work performed, the duration of time the contractor expects to impact the facility and an accessible signed pedestrian detour complaint with MUTCD Section 6D that will be used during each stage of construction. This plan shall be submitted to the engineer for review and approval at or prior to the pre-construction conference. Accessible signed detours shall be in place prior to any work being performed that has the effect of closing an existing pedestrian travel way.

**3.2** When consultant survey is included in the contract, the contractor shall use their survey crews to verify that the intended design can be constructed to the full requirements as established in the 2010 ADA Standards. When 2010 ADA Standards do not give sufficient information to construct the contract work, the contractor shall refer to the PROWAG.

**3.3** When consultant survey is not included in the contract, the contractor shall coordinate with the engineer, prior to construction, to determine if additional survey will be required to confirm the designs constructability.

**4.0 Final Acceptance of Work.** The contractor shall provide the completed ADA Checklist to the engineer at the semi-final inspection. ADA improvements require final inspection and compliance with the ADA requirements and the ADA Checklist. Each item listed in the checklist must receive either a "YES" or an "N/A" score. Any item receiving a "NO" will be deemed non-compliant and shall be corrected at the contractor's expense unless deemed otherwise by the engineer. Documentation must be provided about the location of any non-complaint items that are allowed to remain at the end of the construction project. Specific details of the non-complaint items, the ADA requirement that the work was not able to comply with, and the specific reasons that justify the exception are to be included with the completed ADA Checklist provided to the engineer.

**4.1** Slope and grade measurements shall be made using a properly calibrated, 2 foot long, electronic digital level approved by the engineer.

**5.0 Basis of Payment.** The contractor will receive full pay of the contract unit cost for all sidewalk, ramps, curb ramps, median, islands, approach work, cross walk striping, APS buttons, pedestrian heads, detectible warning systems and temporary traffic control measures that are completed during the current estimate period as approved by the engineer. Based upon completion of the ADA Checklist, the contractor shall complete any necessary adjustments to items deemed non-compliant as directed by the engineer.

**5.1** No direct payment will be made to the contractor to recover the cost of equipment, labor, materials, or time required to fulfill the above provisions, unless specified elsewhere in the contract documents.

#### H. LUMP SUM LAND DISTURBANCE COMPLIANCE

**1.0 Description.** This specification covers the requirements for land disturbance compliance in accordance with Sec. 402 of the Clean Water Act, and Missouri'.

**2.0** The Clean Water Act and associated federal regulations require nearly all construction site operators engaged in clearing, grading, and excavating activities that disturb one acre or more, including smaller sites in a larger common plan of development or sale, to obtain coverage under a National Pollutant Discharge Elimination System (NPDES) permit for their stormwater discharges. Under the NPDES program, the U.S. Environmental Protection Agency (EPA) has authorized the State of Missouri to implement the federal requirements and issue stormwater permits. The Missouri Department of Natural Resources (MoDNR), as administrative agent for the Missouri Clean Water Commission, issues these permits as land disturbance permits. To obtain the permit for compliance with the regulations for land disturbance, it is necessary to request coverage under the MoDNR Missouri State Operating Permit – General Permit. The permit shall be obtained through MoDNR's ePermitting process at [www.dnr.mo.gov/data-e-services/water/electronic-permitting-epermitting](http://www.dnr.mo.gov/data-e-services/water/electronic-permitting-epermitting). It shall be the responsibility of the contractor to obtain such permit for this project.

**3.0** The contractor shall be listed on the permit as the owner and continuing authority. The contractor shall hold harmless the City of St. Martins against any claims, or potential claims, related to failure to comply with the NPDES permit, the Clean Water Act, or the Missouri Clean Water Law. The contractor shall provide a copy of the permit to the engineer prior to the start of construction operations.

**4.0** The contractor shall be responsible for all requirements of the permit, including, but not limited to obtaining the operating permit; developing and implementing the stormwater pollution prevention plan (SWPPP); design, installation, and maintenance of best management practices (BMPs), all land disturbance inspections, and permit closeout.

**5.0** The Civil construction drawings contain a proposed erosion and sediment control plan, which the contractor may use, or an alternate plan can be developed and implemented by the contractor.

**6.0 Method of Measurement** This work will not be measured for payment, but will be considered a lump sum unit. The work will include all work necessary to obtain the NPDES permit from MoDNR, develop the SWPPP, design, provide, install, and maintain all BMP's for the project, conduct compliance inspections in accordance with the land disturbance permit, remove BMP's once stabilization is obtained and close out the land disturbance permit.

**7.0 Basis of Payment.** Accepted Land Disturbance Compliance will be paid for at the contract lump sum price, and will be considered total compensation for all labor, equipment, and material necessary for compliance with this provision and the NPDES land disturbance permit.

I. PAVED APPROACH, 6 IN.

**1.0 Description.** This work shall consist of constructing paved approaches 6 inches thick as shown on the plans or as directed by the engineer.

**2.0 Material** All material shall be in accordance with Sec. 608 and Division 1000, Materials Details.

**3.0 Construction Requirements** Construction shall be in accordance with Sec. 608.

**4.0 Method of Measurement**

**4.1** Paved approaches will be measured from the beginning of the return on one side of the approach to the end of the return on the other side of the approach, to the nearest 1/10 square yard. Integral curb constructed on paved approaches will not be measured or paid for separately but will be included in the contract unit price for paved approaches

**4.2** Final measurement of paved approaches will not be made except for authorized changes during construction, or where appreciable errors are found in the contract quantity. The revision or correction will be computed and added to or deducted from the contract quantity for that item.

**5.0 Basis of Payment** The accepted quantities paved approach 6 in., complete in place, will be paid for at the contract unit price for 608-99.05 Paved Approach 6 IN. by the square yard.

J. 6 IN. BARRIER CURB AND GUTTER

**1.0 Description.** This work shall consist of constructing 6 In. barrier curb and gutter as shown on the plans or as directed by the engineer.

**2.0 Material** All material shall be in accordance with Sec. 609 and Division 1000, Materials Details.

**3.0 Construction Requirements** Construction shall be in accordance with Sec. 609.

**4.0 Method of Measurement** 6 In.curb and gutter will be measured to the nearest linear foot. Measurement will be made along the curb face or along the flow line of gutters exclusive of paved approaches.

**5.0 Basis of Payment** The accepted quantities of 6 In. curb and gutter, complete in place, will be paid for at the contract unit price for 609-99.03, 6 IN. Curb and Gutter, per LF. No direct payment will be made for the following:

- (a) Excavation below the upper surface of the concrete of these items.
- (b) Any work necessary for preparing the subgrade and backfilling the completed item.
- (c) Furnishing or installing reinforcement.

K. ROLL CURB AND GUTTER AT RESIDENTIAL DRIVEWAY

**6.0 Description.** This work shall consist of constructing roll curb and gutter as shown on the plans or as directed by the engineer.

**7.0 Material** All material shall be in accordance Sec. 609 and Division 1000, Materials Details.

**8.0 Construction Requirements** Construction shall be in accordance with Sec. 609.

**9.0 Method of Measurement** Roll curb and gutter will be measured to the nearest linear foot. Measurement will be made along the curb face or along the flow line of gutters exclusive of paved approaches.

**10.0 Basis of Payment** The accepted quantities of roll curb and gutter, complete in place, will be paid for at the contract unit price for 609-99.03 Roll Curb and Gutter, per LF. No direct payment will be made for the following:

- (a) Excavation below the upper surface of the concrete of these items.
- (b) Any work necessary for preparing the subgrade and backfilling the completed item.
- (c) Furnishing or installing reinforcement.

L. 4 IN. PVC DRAIN PIPE

**1.0 Description.** This work shall consist of constructing 4 IN. PVC drain pipes under the proposed sidewalk and through the existing curb openings as shown on the plans or as directed by the engineer.

**2.0 Material** Pipe and fittings shall be 4-inch ASTM 2729 PVC sewer and drain pipe to match existing pipe in the field.

**3.0 Construction Requirements** 4 in. PVC Drain Pipe shall be connected to existing pipe upstream of sidewalk and be routed beneath ADA-compliant trench cover and through the existing curb cut to discharge into the roadway gutter.

**4.0 Method of Measurement** Final measurement will not be made except for authorized changes during construction or where appreciable errors are found in the contract quantity. Where required, measurement of pipe, complete in place, will be made to the nearest foot along the geometrical center of the pipe. The revision or correction will be computed and added to or deducted from the contract quantity.

**5.0 Basis of Payment** The accepted quantities of pipe, complete in place, including all necessary excavation, tees, bends, wyes, coupling bands, cutting and joining new pipe to existing pipe or structures, unless otherwise specified, will be paid for at the contract unit price for 724-99.03, 4 IN. PVC Drain Pipe, per LF.

M. ADA METAL TRENCH COVER

**1.0 Description.** This work shall consist of providing an ADA compliant metal trench cover as shown on the plans or as directed by the engineer. The trench cover shall consist of a metal plate or other structure designed to provide a continuous accessible route along the proposed sidewalk over one (1) or two (2) 4" PVC drain pipes discharging to the adjacent roadway.

**1.1** Trench Cover shall comply with all applicable requirements of the Americans with Disabilities Act and of federal Public Right-of-Way Accessibility Guidelines (PROWAG).

**1.2** Trench Cover shall extend the full width of the sidewalk. Ends shall be cut at an angle as necessary to match the edges of adjacent concrete when installed at an angle not perpendicular to sidewalk.

**1.3** Trench cover shall be approximately 5 inches wide to cover one (1) 4" PVC drain pipe and approximately 10 inches wide to cover two (2) 4" PVC drain pipes.

**2.0 Method of Measurement** Trench Cover shall be measured to the nearest 1/10 square foot measured along the center of the trench cover.

**3.0 Basis of Payment.** The accepted quantities of ADA metal trench covers, complete in place, will be paid for at the contract unit price for 608-99.04 ADA Metal Trench Cover, per SF. Payment will be considered full compensation for all labor, equipment, and materials necessary to complete the described work. No direct payment will be made for cuts required to match edges of proposed sidewalk, or for fastening of separate sections to extend the full width of the sidewalk.

N. SIDEWALK BRIDGE FLUME

**1.0 Description.** This work shall consist of constructing sidewalk bridge flume as shown on the plans or as directed by the engineer.

**2.0 Material** All material shall be in accordance with Sec. 609 and Division 1000, Materials Details.

**3.0 Construction Requirements** Construction shall be in accordance with Sec. 609.

**4.0 Method of Measurement** Sidewalk bridge flume will be measured per lump sum.

**5.0 Basis of Payment** The accepted sidewalk bridge flume, complete in place, will be paid for at the contract unit price for 609-99.01 Sidewalk Bridge Flume, per LS. No direct payment will be made for the following:

- (a) Excavation below the upper surface of the concrete of these items.
- (b) Any work necessary for preparing the subgrade and backfilling the completed item.
- (c) Furnishing or installing reinforcement.

O. REMOVAL AND REPLACEMENT OF LANDSCAPING FEATURES

**1.0** The contractor shall contact all property owners concerning the removal of any landscaping features impacted by construction prior to beginning work. Care shall be taken in order to cause the least disruption to yard areas, plants, shrubs, trees, etc. Any landscaping that is necessary to be removed shall be done so in a way such that the property owner can salvage it, if desired. The contractor shall coordinate all removals with the property owner and, if necessary, shall assist the property owner with relocation. This shall include lawn watering systems.

**2.0** No direct payment will be made to the contractor for the requirements of this provision.



**REQUIRED CONTRACT PROVISIONS  
FEDERAL-AID CONSTRUCTION CONTRACTS**

- I. General
- II. Nondiscrimination
- III. Non-segregated Facilities
- IV. Davis-Bacon and Related Act Provisions
- V. Contract Work Hours and Safety Standards Act Provisions
- VI. Subletting or Assigning the Contract
- VII. Safety: Accident Prevention
- VIII. False Statements Concerning Highway Projects
- IX. Implementation of Clean Air Act and Federal Water Pollution Control Act
- X. Certification Regarding Debarment, Suspension, Ineligibility and Voluntary Exclusion
- XI. Certification Regarding Use of Contract Funds for Lobbying
- XII. Use of United States-Flag Vessels:

**ATTACHMENTS**

A. Employment and Materials Preference for Appalachian Development Highway System or Appalachian Local Access Road Contracts (included in Appalachian contracts only)

**I. GENERAL**

1. Form FHWA-1273 must be physically incorporated in each construction contract funded under title 23, United States Code, as required in 23 CFR 633.102(b) (excluding emergency contracts solely intended for debris removal). The contractor (or subcontractor) must insert this form in each subcontract and further require its inclusion in all lower tier subcontracts (excluding purchase orders, rental agreements and other agreements for supplies or services). 23 CFR 633.102(e).

The applicable requirements of Form FHWA-1273 are incorporated by reference for work done under any purchase order, rental agreement or agreement for other services. The prime contractor shall be responsible for compliance by any subcontractor, lower-tier subcontractor or service provider. 23 CFR 633.102(e).

Form FHWA-1273 must be included in all Federal-aid design-build contracts, in all subcontracts and in lower tier subcontracts (excluding subcontracts for design services, purchase orders, rental agreements and other agreements for supplies or services) in accordance with 23 CFR 633.102. The design-builder shall be responsible for compliance by any subcontractor, lower-tier subcontractor or service provider.

Contracting agencies may reference Form FHWA-1273 in solicitation-for-bids or request-for-proposals documents, however, the Form FHWA-1273 must be physically incorporated (not referenced) in all contracts, subcontracts and lower-tier subcontracts (excluding purchase orders, rental agreements and other agreements for supplies or services related to a construction contract). 23 CFR 633.102(b).

2. Subject to the applicability criteria noted in the following sections, these contract provisions shall apply to all work

performed on the contract by the contractor's own organization and with the assistance of workers under the contractor's immediate superintendence and to all work performed on the contract by piecework, station work, or by subcontract. 23 CFR 633.102(d).

3. A breach of any of the stipulations contained in these Required Contract Provisions may be sufficient grounds for withholding of progress payments, withholding of final payment, termination of the contract, suspension / debarment or any other action determined to be appropriate by the contracting agency and FHWA.

4. Selection of Labor: During the performance of this contract, the contractor shall not use convict labor for any purpose within the limits of a construction project on a Federal-aid highway unless it is labor performed by convicts who are on parole, supervised release, or probation. 23 U.S.C. 114(b). The term Federal-aid highway does not include roadways functionally classified as local roads or rural minor collectors. 23 U.S.C. 101(a).

**II. NONDISCRIMINATION (23 CFR 230.107(a); 23 CFR Part 230, Subpart A, Appendix A; EO 11246)**

The provisions of this section related to 23 CFR Part 230, Subpart A, Appendix A are applicable to all Federal-aid construction contracts and to all related construction subcontracts of \$10,000 or more. The provisions of 23 CFR Part 230 are not applicable to material supply, engineering, or architectural service contracts.

In addition, the contractor and all subcontractors must comply with the following policies: Executive Order 11246, 41 CFR Part 60, 29 CFR Parts 1625-1627, 23 U.S.C. 140, Section 504 of the Rehabilitation Act of 1973, as amended (29 U.S.C. 794), Title VI of the Civil Rights Act of 1964, as amended (42 U.S.C. 2000d et seq.), and related regulations including 49 CFR Parts 21, 26, and 27; and 23 CFR Parts 200, 230, and 633.

The contractor and all subcontractors must comply with: the requirements of the Equal Opportunity Clause in 41 CFR 60-1.4(b) and, for all construction contracts exceeding \$10,000, the Standard Federal Equal Employment Opportunity Construction Contract Specifications in 41 CFR 60-4.3.

Note: The U.S. Department of Labor has exclusive authority to determine compliance with Executive Order 11246 and the policies of the Secretary of Labor including 41 CFR Part 60, and 29 CFR Parts 1625-1627. The contracting agency and the FHWA have the authority and the responsibility to ensure compliance with 23 U.S.C. 140, Section 504 of the Rehabilitation Act of 1973, as amended (29 U.S.C. 794), and Title VI of the Civil Rights Act of 1964, as amended (42 U.S.C. 2000d et seq.), and related regulations including 49 CFR Parts 21, 26, and 27; and 23 CFR Parts 200, 230, and 633.

The following provision is adopted from 23 CFR Part 230, Subpart A, Appendix A, with appropriate revisions to conform to the U.S. Department of Labor (US DOL) and FHWA requirements.

**1. Equal Employment Opportunity:** Equal Employment Opportunity (EEO) requirements not to discriminate and to take affirmative action to assure equal opportunity as set forth under laws, executive orders, rules, regulations (see 28 CFR Part 35, 29 CFR Part 1630, 29 CFR Parts 1625-1627, 41 CFR Part 60 and 49 CFR Part 27) and orders of the Secretary of Labor as modified by the provisions prescribed herein, and imposed pursuant to 23 U.S.C. 140, shall constitute the EEO and specific affirmative action standards for the contractor's project activities under this contract. The provisions of the Americans with Disabilities Act of 1990 (42 U.S.C. 12101 et seq.) set forth under 28 CFR Part 35 and 29 CFR Part 1630 are incorporated by reference in this contract. In the execution of this contract, the contractor agrees to comply with the following minimum specific requirement activities of EEO:

a. The contractor will work with the contracting agency and the Federal Government to ensure that it has made every good faith effort to provide equal opportunity with respect to all of its terms and conditions of employment and in their review of activities under the contract. 23 CFR 230.409 (g)(4) & (5).

b. The contractor will accept as its operating policy the following statement:

"It is the policy of this Company to assure that applicants are employed, and that employees are treated during employment, without regard to their race, religion, sex, sexual orientation, gender identity, color, national origin, age or disability. Such action shall include: employment, upgrading, demotion, or transfer; recruitment or recruitment advertising; layoff or termination; rates of pay or other forms of compensation; and selection for training, including apprenticeship, pre-apprenticeship, and/or on-the-job training."

**2. EEO Officer:** The contractor will designate and make known to the contracting officers an EEO Officer who will have the responsibility for and must be capable of effectively administering and promoting an active EEO program and who must be assigned adequate authority and responsibility to do so.

**3. Dissemination of Policy:** All members of the contractor's staff who are authorized to hire, supervise, promote, and discharge employees, or who recommend such action or are substantially involved in such action, will be made fully cognizant of and will implement the contractor's EEO policy and contractual responsibilities to provide EEO in each grade and classification of employment. To ensure that the above agreement will be met, the following actions will be taken as a minimum:

a. Periodic meetings of supervisory and personnel office employees will be conducted before the start of work and then not less often than once every six months, at which time the contractor's EEO policy and its implementation will be reviewed and explained. The meetings will be conducted by the EEO Officer or other knowledgeable company official.

b. All new supervisory or personnel office employees will be given a thorough indoctrination by the EEO Officer, covering all major aspects of the contractor's EEO obligations within thirty days following their reporting for duty with the contractor.

c. All personnel who are engaged in direct recruitment for the project will be instructed by the EEO Officer in the contractor's procedures for locating and hiring minorities and women.

d. Notices and posters setting forth the contractor's EEO policy will be placed in areas readily accessible to employees, applicants for employment and potential employees.

e. The contractor's EEO policy and the procedures to implement such policy will be brought to the attention of employees by means of meetings, employee handbooks, or other appropriate means.

**4. Recruitment:** When advertising for employees, the contractor will include in all advertisements for employees the notation: "An Equal Opportunity Employer." All such advertisements will be placed in publications having a large circulation among minorities and women in the area from which the project work force would normally be derived.

a. The contractor will, unless precluded by a valid bargaining agreement, conduct systematic and direct recruitment through public and private employee referral sources likely to yield qualified minorities and women. To meet this requirement, the contractor will identify sources of potential minority group employees and establish with such identified sources procedures whereby minority and women applicants may be referred to the contractor for employment consideration.

b. In the event the contractor has a valid bargaining agreement providing for exclusive hiring hall referrals, the contractor is expected to observe the provisions of that agreement to the extent that the system meets the contractor's compliance with EEO contract provisions. Where implementation of such an agreement has the effect of discriminating against minorities or women, or obligates the contractor to do the same, such implementation violates Federal nondiscrimination provisions.

c. The contractor will encourage its present employees to refer minorities and women as applicants for employment. Information and procedures with regard to referring such applicants will be discussed with employees.

**5. Personnel Actions:** Wages, working conditions, and employee benefits shall be established and administered, and personnel actions of every type, including hiring, upgrading, promotion, transfer, demotion, layoff, and termination, shall be taken without regard to race, color, religion, sex, sexual orientation, gender identity, national origin, age or disability. The following procedures shall be followed:

a. The contractor will conduct periodic inspections of project sites to ensure that working conditions and employee facilities do not indicate discriminatory treatment of project site personnel.

b. The contractor will periodically evaluate the spread of wages paid within each classification to determine any evidence of discriminatory wage practices.

c. The contractor will periodically review selected personnel actions in depth to determine whether there is evidence of discrimination. Where evidence is found, the contractor will promptly take corrective action. If the review indicates that the discrimination may extend beyond the actions reviewed, such corrective action shall include all affected persons.

d. The contractor will promptly investigate all complaints of alleged discrimination made to the contractor in connection with its obligations under this contract, will attempt to resolve such complaints, and will take appropriate corrective action

within a reasonable time. If the investigation indicates that the discrimination may affect persons other than the complainant, such corrective action shall include such other persons. Upon completion of each investigation, the contractor will inform every complainant of all of their avenues of appeal.

#### **6. Training and Promotion:**

a. The contractor will assist in locating, qualifying, and increasing the skills of minorities and women who are applicants for employment or current employees. Such efforts should be aimed at developing full journey level status employees in the type of trade or job classification involved.

b. Consistent with the contractor's work force requirements and as permissible under Federal and State regulations, the contractor shall make full use of training programs (i.e., apprenticeship and on-the-job training programs for the geographical area of contract performance). In the event a special provision for training is provided under this contract, this subparagraph will be superseded as indicated in the special provision. The contracting agency may reserve training positions for persons who receive welfare assistance in accordance with 23 U.S.C. 140(a).

c. The contractor will advise employees and applicants for employment of available training programs and entrance requirements for each.

d. The contractor will periodically review the training and promotion potential of employees who are minorities and women and will encourage eligible employees to apply for such training and promotion.

**7. Unions:** If the contractor relies in whole or in part upon unions as a source of employees, the contractor will use good faith efforts to obtain the cooperation of such unions to increase opportunities for minorities and women. 23 CFR 230.409. Actions by the contractor, either directly or through a contractor's association acting as agent, will include the procedures set forth below:

a. The contractor will use good faith efforts to develop, in cooperation with the unions, joint training programs aimed toward qualifying more minorities and women for membership in the unions and increasing the skills of minorities and women so that they may qualify for higher paying employment.

b. The contractor will use good faith efforts to incorporate an EEO clause into each union agreement to the end that such union will be contractually bound to refer applicants without regard to their race, color, religion, sex, sexual orientation, gender identity, national origin, age, or disability.

c. The contractor is to obtain information as to the referral practices and policies of the labor union except that to the extent such information is within the exclusive possession of the labor union and such labor union refuses to furnish such information to the contractor, the contractor shall so certify to the contracting agency and shall set forth what efforts have been made to obtain such information.

d. In the event the union is unable to provide the contractor with a reasonable flow of referrals within the time limit set forth in the collective bargaining agreement, the contractor will, through independent recruitment efforts, fill the employment vacancies without regard to race, color, religion, sex, sexual orientation, gender identity, national origin, age, or disability; making full efforts to obtain qualified and/or qualifiable minorities and women. The failure of a union to provide

sufficient referrals (even though it is obligated to provide exclusive referrals under the terms of a collective bargaining agreement) does not relieve the contractor from the requirements of this paragraph. In the event the union referral practice prevents the contractor from meeting the obligations pursuant to Executive Order 11246, as amended, and these special provisions, such contractor shall immediately notify the contracting agency.

**8. Reasonable Accommodation for Applicants / Employees with Disabilities:** The contractor must be familiar with the requirements for and comply with the Americans with Disabilities Act and all rules and regulations established thereunder. Employers must provide reasonable accommodation in all employment activities unless to do so would cause an undue hardship.

**9. Selection of Subcontractors, Procurement of Materials and Leasing of Equipment:** The contractor shall not discriminate on the grounds of race, color, religion, sex, sexual orientation, gender identity, national origin, age, or disability in the selection and retention of subcontractors, including procurement of materials and leases of equipment. The contractor shall take all necessary and reasonable steps to ensure nondiscrimination in the administration of this contract.

a. The contractor shall notify all potential subcontractors, suppliers, and lessors of their EEO obligations under this contract.

b. The contractor will use good faith efforts to ensure subcontractor compliance with their EEO obligations.

#### **10. Assurances Required:**

a. The requirements of 49 CFR Part 26 and the State DOT's FHWA-approved Disadvantaged Business Enterprise (DBE) program are incorporated by reference.

b. The contractor, subrecipient or subcontractor shall not discriminate on the basis of race, color, national origin, or sex in the performance of this contract. The contractor shall carry out applicable requirements of 49 CFR part 26 in the award and administration of DOT-assisted contracts. Failure by the contractor to carry out these requirements is a material breach of this contract, which may result in the termination of this contract or such other remedy as the recipient deems appropriate, which may include, but is not limited to:

- (1) Withholding monthly progress payments;
- (2) Assessing sanctions;
- (3) Liquidated damages; and/or
- (4) Disqualifying the contractor from future bidding as non-responsible.

c. The Title VI and nondiscrimination provisions of U.S. DOT Order 1050.2A at Appendixes A and E are incorporated by reference. 49 CFR Part 21.

**11. Records and Reports:** The contractor shall keep such records as necessary to document compliance with the EEO requirements. Such records shall be retained for a period of three years following the date of the final payment to the contractor for all contract work and shall be available at reasonable times and places for inspection by authorized representatives of the contracting agency and the FHWA.

a. The records kept by the contractor shall document the following:

(1) The number and work hours of minority and non-minority group members and women employed in each work classification on the project;

(2) The progress and efforts being made in cooperation with unions, when applicable, to increase employment opportunities for minorities and women; and

(3) The progress and efforts being made in locating, hiring, training, qualifying, and upgrading minorities and women.

b. The contractors and subcontractors will submit an annual report to the contracting agency each July for the duration of the project indicating the number of minority, women, and non-minority group employees currently engaged in each work classification required by the contract work. This information is to be reported on [Form FHWA-1391](#). The staffing data should represent the project work force on board in all or any part of the last payroll period preceding the end of July. If on-the-job training is being required by special provision, the contractor will be required to collect and report training data. The employment data should reflect the work force on board during all or any part of the last payroll period preceding the end of July.

### III. NONSEGREGATED FACILITIES

This provision is applicable to all Federal-aid construction contracts and to all related construction subcontracts of more than \$10,000. 41 CFR 60-1.5.

As prescribed by 41 CFR 60-1.8, the contractor must ensure that facilities provided for employees are provided in such a manner that segregation on the basis of race, color, religion, sex, sexual orientation, gender identity, or national origin cannot result. The contractor may neither require such segregated use by written or oral policies nor tolerate such use by employee custom. The contractor's obligation extends further to ensure that its employees are not assigned to perform their services at any location under the contractor's control where the facilities are segregated. The term "facilities" includes waiting rooms, work areas, restaurants and other eating areas, time clocks, restrooms, washrooms, locker rooms and other storage or dressing areas, parking lots, drinking fountains, recreation or entertainment areas, transportation, and housing provided for employees. The contractor shall provide separate or single-user restrooms and necessary dressing or sleeping areas to assure privacy between sexes.

### IV. DAVIS-BACON AND RELATED ACT PROVISIONS

This section is applicable to all Federal-aid construction projects exceeding \$2,000 and to all related subcontracts and lower-tier subcontracts (regardless of subcontract size), in accordance with 29 CFR 5.5. The requirements apply to all projects located within the right-of-way of a roadway that is functionally classified as Federal-aid highway. 23 U.S.C. 113. This excludes roadways functionally classified as local roads or rural minor collectors, which are exempt. 23 U.S.C. 101. Where applicable law requires that projects be treated as a project on a Federal-aid highway, the provisions of this subpart will apply regardless of the location of the project. Examples include: Surface Transportation Block Grant Program projects funded under 23 U.S.C. 133 [excluding recreational trails projects], the Nationally Significant Freight and Highway

Projects funded under 23 U.S.C. 117, and National Highway Freight Program projects funded under 23 U.S.C. 167.

The following provisions are from the U.S. Department of Labor regulations in 29 CFR 5.5 "Contract provisions and related matters" with minor revisions to conform to the FHWA-1273 format and FHWA program requirements.

#### 1. Minimum wages (29 CFR 5.5)

a. *Wage rates and fringe benefits.* All laborers and mechanics employed or working upon the site of the work (or otherwise working in construction or development of the project under a development statute), will be paid unconditionally and not less often than once a week, and without subsequent deduction or rebate on any account (except such payroll deductions as are permitted by regulations issued by the Secretary of Labor under the Copeland Act ([29 CFR part 3](#))), the full amount of basic hourly wages and bona fide fringe benefits (or cash equivalents thereof) due at time of payment computed at rates not less than those contained in the wage determination of the Secretary of Labor which is attached hereto and made a part hereof, regardless of any contractual relationship which may be alleged to exist between the contractor and such laborers and mechanics. As provided in paragraphs (d) and (e) of 29 CFR 5.5, the appropriate wage determinations are effective by operation of law even if they have not been attached to the contract. Contributions made or costs reasonably anticipated for bona fide fringe benefits under the Davis-Bacon Act ([40 U.S.C. 3141\(2\)\(B\)](#)) on behalf of laborers or mechanics are considered wages paid to such laborers or mechanics, subject to the provisions of paragraph 1.e. of this section; also, regular contributions made or costs incurred for more than a weekly period (but not less often than quarterly) under plans, funds, or programs which cover the particular weekly period, are deemed to be constructively made or incurred during such weekly period. Such laborers and mechanics must be paid the appropriate wage rate and fringe benefits on the wage determination for the classification(s) of work actually performed, without regard to skill, except as provided in paragraph 4. of this section. Laborers or mechanics performing work in more than one classification may be compensated at the rate specified for each classification for the time actually worked therein: *Provided*, That the employer's payroll records accurately set forth the time spent in each classification in which work is performed. The wage determination (including any additional classifications and wage rates conformed under paragraph 1.c. of this section) and the Davis-Bacon poster (WH-1321) must be posted at all times by the contractor and its subcontractors at the site of the work in a prominent and accessible place where it can be easily seen by the workers.

b. *Frequently recurring classifications.* (1) In addition to wage and fringe benefit rates that have been determined to be prevailing under the procedures set forth in [29 CFR part 1](#), a wage determination may contain, pursuant to § 1.3(f), wage and fringe benefit rates for classifications of laborers and mechanics for which conformance requests are regularly submitted pursuant to paragraph 1.c. of this section, provided that:

(i) The work performed by the classification is not performed by a classification in the wage determination for which a prevailing wage rate has been determined;

(ii) The classification is used in the area by the construction industry; and

(iii) The wage rate for the classification bears a reasonable relationship to the prevailing wage rates contained in the wage determination.

(2) The Administrator will establish wage rates for such classifications in accordance with paragraph 1.c.(1)(iii) of this section. Work performed in such a classification must be paid at no less than the wage and fringe benefit rate listed on the wage determination for such classification.

c. *Conformance.* (1) The contracting officer must require that any class of laborers or mechanics, including helpers, which is not listed in the wage determination and which is to be employed under the contract be classified in conformance with the wage determination. Conformance of an additional classification and wage rate and fringe benefits is appropriate only when the following criteria have been met:

(i) The work to be performed by the classification requested is not performed by a classification in the wage determination; and

(ii) The classification is used in the area by the construction industry; and

(iii) The proposed wage rate, including any bona fide fringe benefits, bears a reasonable relationship to the wage rates contained in the wage determination.

(2) The conformance process may not be used to split, subdivide, or otherwise avoid application of classifications listed in the wage determination.

(3) If the contractor and the laborers and mechanics to be employed in the classification (if known), or their representatives, and the contracting officer agree on the classification and wage rate (including the amount designated for fringe benefits where appropriate), a report of the action taken will be sent by the contracting officer by email to [DBAconformance@dol.gov](mailto:DBAconformance@dol.gov). The Administrator, or an authorized representative, will approve, modify, or disapprove every additional classification action within 30 days of receipt and so advise the contracting officer or will notify the contracting officer within the 30-day period that additional time is necessary.

(4) In the event the contractor, the laborers or mechanics to be employed in the classification or their representatives, and the contracting officer do not agree on the proposed classification and wage rate (including the amount designated for fringe benefits, where appropriate), the contracting officer will, by email to [DBAconformance@dol.gov](mailto:DBAconformance@dol.gov), refer the questions, including the views of all interested parties and the recommendation of the contracting officer, to the Administrator for determination. The Administrator, or an authorized representative, will issue a determination within 30 days of receipt and so advise the contracting officer or will notify the contracting officer within the 30-day period that additional time is necessary.

(5) The contracting officer must promptly notify the contractor of the action taken by the Wage and Hour Division

under paragraphs 1.c.(3) and (4) of this section. The contractor must furnish a written copy of such determination to each affected worker or it must be posted as a part of the wage determination. The wage rate (including fringe benefits where appropriate) determined pursuant to paragraph 1.c.(3) or (4) of this section must be paid to all workers performing work in the classification under this contract from the first day on which work is performed in the classification.

d. *Fringe benefits not expressed as an hourly rate.* Whenever the minimum wage rate prescribed in the contract for a class of laborers or mechanics includes a fringe benefit which is not expressed as an hourly rate, the contractor may either pay the benefit as stated in the wage determination or may pay another bona fide fringe benefit or an hourly cash equivalent thereof.

e. *Unfunded plans.* If the contractor does not make payments to a trustee or other third person, the contractor may consider as part of the wages of any laborer or mechanic the amount of any costs reasonably anticipated in providing bona fide fringe benefits under a plan or program, *Provided*, That the Secretary of Labor has found, upon the written request of the contractor, in accordance with the criteria set forth in § 5.28, that the applicable standards of the Davis-Bacon Act have been met. The Secretary of Labor may require the contractor to set aside in a separate account assets for the meeting of obligations under the plan or program.

f. *Interest.* In the event of a failure to pay all or part of the wages required by the contract, the contractor will be required to pay interest on any underpayment of wages.

## 2. Withholding (29 CFR 5.5)

a. *Withholding requirements.* The contracting agency may, upon its own action, or must, upon written request of an authorized representative of the Department of Labor, withhold or cause to be withheld from the contractor so much of the accrued payments or advances as may be considered necessary to satisfy the liabilities of the prime contractor or any subcontractor for the full amount of wages and monetary relief, including interest, required by the clauses set forth in this section for violations of this contract, or to satisfy any such liabilities required by any other Federal contract, or federally assisted contract subject to Davis-Bacon labor standards, that is held by the same prime contractor (as defined in § 5.2). The necessary funds may be withheld from the contractor under this contract, any other Federal contract with the same prime contractor, or any other federally assisted contract that is subject to Davis-Bacon labor standards requirements and is held by the same prime contractor, regardless of whether the other contract was awarded or assisted by the same agency, and such funds may be used to satisfy the contractor liability for which the funds were withheld. In the event of a contractor's failure to pay any laborer or mechanic, including any apprentice or helper working on the site of the work all or part of the wages required by the contract, or upon the contractor's failure to submit the required records as discussed in paragraph 3.d. of this section, the contracting agency may on its own initiative and after written notice to the contractor, take such action as may be necessary to cause the suspension of any further payment, advance, or guarantee of funds until such violations have ceased.

b. *Priority to withheld funds.* The Department has priority to funds withheld or to be withheld in accordance with paragraph

2.a. of this section or Section V, paragraph 3.a., or both, over claims to those funds by:

- (1) A contractor's surety(ies), including without limitation performance bond sureties and payment bond sureties;
- (2) A contracting agency for its procurement costs;
- (3) A trustee(s) (either a court-appointed trustee or a U.S. trustee, or both) in bankruptcy of a contractor, or a contractor's bankruptcy estate;
- (4) A contractor's assignee(s);
- (5) A contractor's successor(s); or
- (6) A claim asserted under the Prompt Payment Act, [31 U.S.C. 3901–3907](#).

### 3. Records and certified payrolls (29 CFR 5.5)

*a. Basic record requirements (1) Length of record retention.* All regular payrolls and other basic records must be maintained by the contractor and any subcontractor during the course of the work and preserved for all laborers and mechanics working at the site of the work (or otherwise working in construction or development of the project under a development statute) for a period of at least 3 years after all the work on the prime contract is completed.

*(2) Information required.* Such records must contain the name; Social Security number; last known address, telephone number, and email address of each such worker; each worker's correct classification(s) of work actually performed; hourly rates of wages paid (including rates of contributions or costs anticipated for bona fide fringe benefits or cash equivalents thereof of the types described in [40 U.S.C. 3141\(2\)\(B\)](#) of the Davis-Bacon Act); daily and weekly number of hours actually worked in total and on each covered contract; deductions made; and actual wages paid.

*(3) Additional records relating to fringe benefits.* Whenever the Secretary of Labor has found under paragraph 1.e. of this section that the wages of any laborer or mechanic include the amount of any costs reasonably anticipated in providing benefits under a plan or program described in [40 U.S.C. 3141\(2\)\(B\)](#) of the Davis-Bacon Act, the contractor must maintain records which show that the commitment to provide such benefits is enforceable, that the plan or program is financially responsible, and that the plan or program has been communicated in writing to the laborers or mechanics affected, and records which show the costs anticipated or the actual cost incurred in providing such benefits.

*(4) Additional records relating to apprenticeship.* Contractors with apprentices working under approved programs must maintain written evidence of the registration of apprenticeship programs, the registration of the apprentices, and the ratios and wage rates prescribed in the applicable programs.

*b. Certified payroll requirements (1) Frequency and method of submission.* The contractor or subcontractor must submit weekly, for each week in which any DBA- or Related Acts-covered work is performed, certified payrolls to the contracting

agency. The prime contractor is responsible for the submission of all certified payrolls by all subcontractors. A contracting agency or prime contractor may permit or require contractors to submit certified payrolls through an electronic system, as long as the electronic system requires a legally valid electronic signature; the system allows the contractor, the contracting agency, and the Department of Labor to access the certified payrolls upon request for at least 3 years after the work on the prime contract has been completed; and the contracting agency or prime contractor permits other methods of submission in situations where the contractor is unable or limited in its ability to use or access the electronic system.

*(2) Information required.* The certified payrolls submitted must set out accurately and completely all of the information required to be maintained under paragraph 3.a.(2) of this section, except that full Social Security numbers and last known addresses, telephone numbers, and email addresses must not be included on weekly transmittals. Instead, the certified payrolls need only include an individually identifying number for each worker ( e.g., the last four digits of the worker's Social Security number). The required weekly certified payroll information may be submitted using Optional Form WH-347 or in any other format desired. Optional Form WH-347 is available for this purpose from the Wage and Hour Division website at <https://www.dol.gov/sites/dolgov/files/WHD/legacy/files/wh347.pdf> or its successor website. It is not a violation of this section for a prime contractor to require a subcontractor to provide full Social Security numbers and last known addresses, telephone numbers, and email addresses to the prime contractor for its own records, without weekly submission by the subcontractor to the contracting agency.

*(3) Statement of Compliance.* Each certified payroll submitted must be accompanied by a "Statement of Compliance," signed by the contractor or subcontractor, or the contractor's or subcontractor's agent who pays or supervises the payment of the persons working on the contract, and must certify the following:

(i) That the certified payroll for the payroll period contains the information required to be provided under paragraph 3.b. of this section, the appropriate information and basic records are being maintained under paragraph 3.a. of this section, and such information and records are correct and complete;

(ii) That each laborer or mechanic (including each helper and apprentice) working on the contract during the payroll period has been paid the full weekly wages earned, without rebate, either directly or indirectly, and that no deductions have been made either directly or indirectly from the full wages earned, other than permissible deductions as set forth in [29 CFR part 3](#); and

(iii) That each laborer or mechanic has been paid not less than the applicable wage rates and fringe benefits or cash equivalents for the classification(s) of work actually performed, as specified in the applicable wage determination incorporated into the contract.

*(4) Use of Optional Form WH-347.* The weekly submission of a properly executed certification set forth on the reverse side of Optional Form WH-347 will satisfy the requirement for submission of the "Statement of Compliance" required by paragraph 3.b.(3) of this section.



(5) *Signature.* The signature by the contractor, subcontractor, or the contractor's or subcontractor's agent must be an original handwritten signature or a legally valid electronic signature.

(6) *Falsification.* The falsification of any of the above certifications may subject the contractor or subcontractor to civil or criminal prosecution under [18 U.S.C. 1001](#) and [31 U.S.C. 3729](#).

(7) *Length of certified payroll retention.* The contractor or subcontractor must preserve all certified payrolls during the course of the work and for a period of 3 years after all the work on the prime contract is completed.

c. *Contracts, subcontracts, and related documents.* The contractor or subcontractor must maintain this contract or subcontract and related documents including, without limitation, bids, proposals, amendments, modifications, and extensions. The contractor or subcontractor must preserve these contracts, subcontracts, and related documents during the course of the work and for a period of 3 years after all the work on the prime contract is completed.

d. *Required disclosures and access (1) Required record disclosures and access to workers.* The contractor or subcontractor must make the records required under paragraphs 3.a. through 3.c. of this section, and any other documents that the contracting agency, the State DOT, the FHWA, or the Department of Labor deems necessary to determine compliance with the labor standards provisions of any of the applicable statutes referenced by § 5.1, available for inspection, copying, or transcription by authorized representatives of the contracting agency, the State DOT, the FHWA, or the Department of Labor, and must permit such representatives to interview workers during working hours on the job.

(2) *Sanctions for non-compliance with records and worker access requirements.* If the contractor or subcontractor fails to submit the required records or to make them available, or refuses to permit worker interviews during working hours on the job, the Federal agency may, after written notice to the contractor, sponsor, applicant, owner, or other entity, as the case may be, that maintains such records or that employs such workers, take such action as may be necessary to cause the suspension of any further payment, advance, or guarantee of funds. Furthermore, failure to submit the required records upon request or to make such records available, or to permit worker interviews during working hours on the job, may be grounds for debarment action pursuant to § 5.12. In addition, any contractor or other person that fails to submit the required records or make those records available to WHD within the time WHD requests that the records be produced will be precluded from introducing as evidence in an administrative proceeding under [29 CFR part 6](#) any of the required records that were not provided or made available to WHD. WHD will take into consideration a reasonable request from the contractor or person for an extension of the time for submission of records. WHD will determine the reasonableness of the request and may consider, among other things, the location of the records and the volume of production.

(3) *Required information disclosures.* Contractors and subcontractors must maintain the full Social Security number and last known address, telephone number, and email address

of each covered worker, and must provide them upon request to the contracting agency, the State DOT, the FHWA, the contractor, or the Wage and Hour Division of the Department of Labor for purposes of an investigation or other compliance action.

#### **4. Apprentices and equal employment opportunity (29 CFR 5.5)**

a. *Apprentices (1) Rate of pay.* Apprentices will be permitted to work at less than the predetermined rate for the work they perform when they are employed pursuant to and individually registered in a bona fide apprenticeship program registered with the U.S. Department of Labor, Employment and Training Administration, Office of Apprenticeship (OA), or with a State Apprenticeship Agency recognized by the OA. A person who is not individually registered in the program, but who has been certified by the OA or a State Apprenticeship Agency (where appropriate) to be eligible for probationary employment as an apprentice, will be permitted to work at less than the predetermined rate for the work they perform in the first 90 days of probationary employment as an apprentice in such a program. In the event the OA or a State Apprenticeship Agency recognized by the OA withdraws approval of an apprenticeship program, the contractor will no longer be permitted to use apprentices at less than the applicable predetermined rate for the work performed until an acceptable program is approved.

(2) *Fringe benefits.* Apprentices must be paid fringe benefits in accordance with the provisions of the apprenticeship program. If the apprenticeship program does not specify fringe benefits, apprentices must be paid the full amount of fringe benefits listed on the wage determination for the applicable classification. If the Administrator determines that a different practice prevails for the applicable apprentice classification, fringe benefits must be paid in accordance with that determination.

(3) *Apprenticeship ratio.* The allowable ratio of apprentices to journeyworkers on the job site in any craft classification must not be greater than the ratio permitted to the contractor as to the entire work force under the registered program or the ratio applicable to the locality of the project pursuant to paragraph 4.a.(4) of this section. Any worker listed on a payroll at an apprentice wage rate, who is not registered or otherwise employed as stated in paragraph 4.a.(1) of this section, must be paid not less than the applicable wage rate on the wage determination for the classification of work actually performed. In addition, any apprentice performing work on the job site in excess of the ratio permitted under this section must be paid not less than the applicable wage rate on the wage determination for the work actually performed.

(4) *Reciprocity of ratios and wage rates.* Where a contractor is performing construction on a project in a locality other than the locality in which its program is registered, the ratios and wage rates (expressed in percentages of the journeyworker's hourly rate) applicable within the locality in which the construction is being performed must be observed. If there is no applicable ratio or wage rate for the locality of the project, the ratio and wage rate specified in the contractor's registered program must be observed.

b. *Equal employment opportunity.* The use of apprentices and journeyworkers under this part must be in conformity with

the equal employment opportunity requirements of Executive Order 11246, as amended, and [29 CFR part 30](#).

c. Apprentices and Trainees (programs of the U.S. DOT).

Apprentices and trainees working under apprenticeship and skill training programs which have been certified by the Secretary of Transportation as promoting EEO in connection with Federal-aid highway construction programs are not subject to the requirements of paragraph 4 of this Section IV. 23 CFR 230.111(e)(2). The straight time hourly wage rates for apprentices and trainees under such programs will be established by the particular programs. The ratio of apprentices and trainees to journeyworkers shall not be greater than permitted by the terms of the particular program.

**5. Compliance with Copeland Act requirements.** The contractor shall comply with the requirements of 29 CFR part 3, which are incorporated by reference in this contract as provided in 29 CFR 5.5.

**6. Subcontracts.** The contractor or subcontractor must insert FHWA-1273 in any subcontracts, along with the applicable wage determination(s) and such other clauses or contract modifications as the contracting agency may by appropriate instructions require, and a clause requiring the subcontractors to include these clauses and wage determination(s) in any lower tier subcontracts. The prime contractor is responsible for the compliance by any subcontractor or lower tier subcontractor with all the contract clauses in this section. In the event of any violations of these clauses, the prime contractor and any subcontractor(s) responsible will be liable for any unpaid wages and monetary relief, including interest from the date of the underpayment or loss, due to any workers of lower-tier subcontractors, and may be subject to debarment, as appropriate. 29 CFR 5.5.

**7. Contract termination: debarment.** A breach of the contract clauses in 29 CFR 5.5 may be grounds for termination of the contract, and for debarment as a contractor and a subcontractor as provided in 29 CFR 5.12.

**8. Compliance with Davis-Bacon and Related Act requirements.** All rulings and interpretations of the Davis-Bacon and Related Acts contained in 29 CFR parts 1, 3, and 5 are herein incorporated by reference in this contract as provided in 29 CFR 5.5.

**9. Disputes concerning labor standards.** As provided in 29 CFR 5.5, disputes arising out of the labor standards provisions of this contract shall not be subject to the general disputes clause of this contract. Such disputes shall be resolved in accordance with the procedures of the Department of Labor set forth in 29 CFR parts 5, 6, and 7. Disputes within the meaning of this clause include disputes between the contractor (or any of its subcontractors) and the contracting agency, the U.S. Department of Labor, or the employees or their representatives.

**10. Certification of eligibility.** a. By entering into this contract, the contractor certifies that neither it nor any person or firm who has an interest in the contractor's firm is a person or firm ineligible to be awarded Government contracts by virtue of [40 U.S.C. 3144\(b\)](#) or § 5.12(a).

b. No part of this contract shall be subcontracted to any person or firm ineligible for award of a Government contract by virtue of [40 U.S.C. 3144\(b\)](#) or § 5.12(a).

c. The penalty for making false statements is prescribed in the U.S. Code, Title 18 Crimes and Criminal Procedure, [18 U.S.C. 1001](#).

**11. Anti-retaliation.** It is unlawful for any person to discharge, demote, intimidate, threaten, restrain, coerce, blacklist, harass, or in any other manner discriminate against, or to cause any person to discharge, demote, intimidate, threaten, restrain, coerce, blacklist, harass, or in any other manner discriminate against, any worker or job applicant for:

a. Notifying any contractor of any conduct which the worker reasonably believes constitutes a violation of the DBA, Related Acts, this part, or [29 CFR part 1](#) or [3](#);

b. Filing any complaint, initiating or causing to be initiated any proceeding, or otherwise asserting or seeking to assert on behalf of themselves or others any right or protection under the DBA, Related Acts, this part, or [29 CFR part 1](#) or [3](#);

c. Cooperating in any investigation or other compliance action, or testifying in any proceeding under the DBA, Related Acts, this part, or [29 CFR part 1](#) or [3](#); or

d. Informing any other person about their rights under the DBA, Related Acts, this part, or [29 CFR part 1](#) or [3](#).

## V. CONTRACT WORK HOURS AND SAFETY STANDARDS ACT

Pursuant to 29 CFR 5.5(b), the following clauses apply to any Federal-aid construction contract in an amount in excess of \$100,000 and subject to the overtime provisions of the Contract Work Hours and Safety Standards Act. These clauses shall be inserted in addition to the clauses required by 29 CFR 5.5(a) or 29 CFR 4.6. As used in this paragraph, the terms laborers and mechanics include watchpersons and guards.

**1. Overtime requirements.** No contractor or subcontractor contracting for any part of the contract work which may require or involve the employment of laborers or mechanics shall require or permit any such laborer or mechanic in any workweek in which he or she is employed on such work to work in excess of forty hours in such workweek unless such laborer or mechanic receives compensation at a rate not less than one and one-half times the basic rate of pay for all hours worked in excess of forty hours in such workweek. 29 CFR 5.5.

**2. Violation; liability for unpaid wages; liquidated damages.** In the event of any violation of the clause set forth in paragraph 1. of this section the contractor and any subcontractor responsible therefor shall be liable for the unpaid wages and interest from the date of the underpayment. In addition, such contractor and subcontractor shall be liable to the United States (in the case of work done under contract for the District of Columbia or a territory, to such District or to such territory), for liquidated damages. Such liquidated damages shall be computed with respect to each individual laborer or



mechanic, including watchpersons and guards, employed in violation of the clause set forth in paragraph 1. of this section, in the sum currently provided in 29 CFR 5.5(b)(2)\* for each calendar day on which such individual was required or permitted to work in excess of the standard workweek of forty hours without payment of the overtime wages required by the clause set forth in paragraph 1. of this section.

\* \$31 as of January 15, 2023 (See 88 FR 88 FR 2210) as may be adjusted annually by the Department of Labor, pursuant to the Federal Civil Penalties Inflation Adjustment Act of 1990.

### 3. Withholding for unpaid wages and liquidated damages

a. *Withholding process.* The FHWA or the contracting agency may, upon its own action, or must, upon written request of an authorized representative of the Department of Labor, withhold or cause to be withheld from the contractor so much of the accrued payments or advances as may be considered necessary to satisfy the liabilities of the prime contractor or any subcontractor for any unpaid wages; monetary relief, including interest; and liquidated damages required by the clauses set forth in this section on this contract, any other Federal contract with the same prime contractor, or any other federally assisted contract subject to the Contract Work Hours and Safety Standards Act that is held by the same prime contractor (as defined in § 5.2). The necessary funds may be withheld from the contractor under this contract, any other Federal contract with the same prime contractor, or any other federally assisted contract that is subject to the Contract Work Hours and Safety Standards Act and is held by the same prime contractor, regardless of whether the other contract was awarded or assisted by the same agency, and such funds may be used to satisfy the contractor liability for which the funds were withheld.

b. *Priority to withheld funds.* The Department has priority to funds withheld or to be withheld in accordance with Section IV paragraph 2.a. or paragraph 3.a. of this section, or both, over claims to those funds by:

- (1) A contractor's surety(ies), including without limitation performance bond sureties and payment bond sureties;
- (2) A contracting agency for its procurement costs;
- (3) A trustee(s) (either a court-appointed trustee or a U.S. trustee, or both) in bankruptcy of a contractor, or a contractor's bankruptcy estate;
- (4) A contractor's assignee(s);
- (5) A contractor's successor(s); or
- (6) A claim asserted under the Prompt Payment Act, [31 U.S.C. 3901](#)–3907.

4. **Subcontracts.** The contractor or subcontractor must insert in any subcontracts the clauses set forth in paragraphs 1. through 5. of this section and a clause requiring the subcontractors to include these clauses in any lower tier subcontracts. The prime contractor is responsible for compliance by any subcontractor or lower tier subcontractor with the clauses set forth in paragraphs 1. through 5. In the

event of any violations of these clauses, the prime contractor and any subcontractor(s) responsible will be liable for any unpaid wages and monetary relief, including interest from the date of the underpayment or loss, due to any workers of lower-tier subcontractors, and associated liquidated damages and may be subject to debarment, as appropriate.

**5. Anti-retaliation.** It is unlawful for any person to discharge, demote, intimidate, threaten, restrain, coerce, blacklist, harass, or in any other manner discriminate against, or to cause any person to discharge, demote, intimidate, threaten, restrain, coerce, blacklist, harass, or in any other manner discriminate against, any worker or job applicant for:

a. Notifying any contractor of any conduct which the worker reasonably believes constitutes a violation of the Contract Work Hours and Safety Standards Act (CWHSSA) or its implementing regulations in this part;

b. Filing any complaint, initiating or causing to be initiated any proceeding, or otherwise asserting or seeking to assert on behalf of themselves or others any right or protection under CWHSSA or this part;

c. Cooperating in any investigation or other compliance action, or testifying in any proceeding under CWHSSA or this part; or

d. Informing any other person about their rights under CWHSSA or this part.

### VI. SUBLETTING OR ASSIGNING THE CONTRACT

This provision is applicable to all Federal-aid construction contracts on the National Highway System pursuant to 23 CFR 635.116.

1. The contractor shall perform with its own organization contract work amounting to not less than 30 percent (or a greater percentage if specified elsewhere in the contract) of the total original contract price, excluding any specialty items designated by the contracting agency. Specialty items may be performed by subcontract and the amount of any such specialty items performed may be deducted from the total original contract price before computing the amount of work required to be performed by the contractor's own organization (23 CFR 635.116).

a. The term "perform work with its own organization" in paragraph 1 of Section VI refers to workers employed or leased by the prime contractor, and equipment owned or rented by the prime contractor, with or without operators. Such term does not include employees or equipment of a subcontractor or lower tier subcontractor, agents of the prime contractor, or any other assignees. The term may include payments for the costs of hiring leased employees from an employee leasing firm meeting all relevant Federal and State regulatory requirements. Leased employees may only be included in this term if the prime contractor meets all of the following conditions: (based on longstanding interpretation)

- (1) the prime contractor maintains control over the supervision of the day-to-day activities of the leased employees;
- (2) the prime contractor remains responsible for the quality of the work of the leased employees;

- (3) the prime contractor retains all power to accept or exclude individual employees from work on the project; and
- (4) the prime contractor remains ultimately responsible for the payment of predetermined minimum wages, the submission of payrolls, statements of compliance and all other Federal regulatory requirements.

b. "Specialty Items" shall be construed to be limited to work that requires highly specialized knowledge, abilities, or equipment not ordinarily available in the type of contracting organizations qualified and expected to bid or propose on the contract as a whole and in general are to be limited to minor components of the overall contract. 23 CFR 635.102.

2. Pursuant to 23 CFR 635.116(a), the contract amount upon which the requirements set forth in paragraph (1) of Section VI is computed includes the cost of material and manufactured products which are to be purchased or produced by the contractor under the contract provisions.

3. Pursuant to 23 CFR 635.116(c), the contractor shall furnish (a) a competent superintendent or supervisor who is employed by the firm, has full authority to direct performance of the work in accordance with the contract requirements, and is in charge of all construction operations (regardless of who performs the work) and (b) such other of its own organizational resources (supervision, management, and engineering services) as the contracting officer determines is necessary to assure the performance of the contract.

4. No portion of the contract shall be sublet, assigned or otherwise disposed of except with the written consent of the contracting officer, or authorized representative, and such consent when given shall not be construed to relieve the contractor of any responsibility for the fulfillment of the contract. Written consent will be given only after the contracting agency has assured that each subcontract is evidenced in writing and that it contains all pertinent provisions and requirements of the prime contract. (based on long-standing interpretation of 23 CFR 635.116).

5. The 30-percent self-performance requirement of paragraph (1) is not applicable to design-build contracts; however, contracting agencies may establish their own self-performance requirements. 23 CFR 635.116(d).

## VII. SAFETY: ACCIDENT PREVENTION

This provision is applicable to all Federal-aid construction contracts and to all related subcontracts.

1. In the performance of this contract the contractor shall comply with all applicable Federal, State, and local laws governing safety, health, and sanitation (23 CFR Part 635). The contractor shall provide all safeguards, safety devices and protective equipment and take any other needed actions as it determines, or as the contracting officer may determine, to be reasonably necessary to protect the life and health of employees on the job and the safety of the public and to protect property in connection with the performance of the work covered by the contract. 23 CFR 635.108.

2. It is a condition of this contract, and shall be made a condition of each subcontract, which the contractor enters into pursuant to this contract, that the contractor and any subcontractor shall not permit any employee, in performance of the contract, to work in surroundings or under conditions which are unsanitary, hazardous or dangerous to his/her health or safety, as determined under construction safety and

health standards (29 CFR Part 1926) promulgated by the Secretary of Labor, in accordance with Section 107 of the Contract Work Hours and Safety Standards Act (40 U.S.C. 3704). 29 CFR 1926.10.

3. Pursuant to 29 CFR 1926.3, it is a condition of this contract that the Secretary of Labor or authorized representative thereof, shall have right of entry to any site of contract performance to inspect or investigate the matter of compliance with the construction safety and health standards and to carry out the duties of the Secretary under Section 107 of the Contract Work Hours and Safety Standards Act (40 U.S.C. 3704).

## VIII. FALSE STATEMENTS CONCERNING HIGHWAY PROJECTS

This provision is applicable to all Federal-aid construction contracts and to all related subcontracts.

In order to assure high quality and durable construction in conformity with approved plans and specifications and a high degree of reliability on statements and representations made by engineers, contractors, suppliers, and workers on Federal-aid highway projects, it is essential that all persons concerned with the project perform their functions as carefully, thoroughly, and honestly as possible. Willful falsification, distortion, or misrepresentation with respect to any facts related to the project is a violation of Federal law. To prevent any misunderstanding regarding the seriousness of these and similar acts, Form FHWA-1022 shall be posted on each Federal-aid highway project (23 CFR Part 635) in one or more places where it is readily available to all persons concerned with the project:

18 U.S.C. 1020 reads as follows:

"Whoever, being an officer, agent, or employee of the United States, or of any State or Territory, or whoever, whether a person, association, firm, or corporation, knowingly makes any false statement, false representation, or false report as to the character, quality, quantity, or cost of the material used or to be used, or the quantity or quality of the work performed or to be performed, or the cost thereof in connection with the submission of plans, maps, specifications, contracts, or costs of construction on any highway or related project submitted for approval to the Secretary of Transportation; or

Whoever knowingly makes any false statement, false representation, false report or false claim with respect to the character, quality, quantity, or cost of any work performed or to be performed, or materials furnished or to be furnished, in connection with the construction of any highway or related project approved by the Secretary of Transportation; or

Whoever knowingly makes any false statement or false representation as to material fact in any statement, certificate, or report submitted pursuant to provisions of the Federal-aid Roads Act approved July 11, 1916, (39 Stat. 355), as amended and supplemented;

Shall be fined under this title or imprisoned not more than 5 years or both."

**IX. IMPLEMENTATION OF CLEAN AIR ACT AND FEDERAL WATER POLLUTION CONTROL ACT (42 U.S.C. 7606; 2 CFR 200.88; EO 11738)**

This provision is applicable to all Federal-aid construction contracts in excess of \$150,000 and to all related subcontracts. 48 CFR 2.101; 2 CFR 200.327.

By submission of this bid/proposal or the execution of this contract or subcontract, as appropriate, the bidder, proposer, Federal-aid construction contractor, subcontractor, supplier, or vendor agrees to comply with all applicable standards, orders or regulations issued pursuant to the Clean Air Act (42 U.S.C. 7401-7671q) and the Federal Water Pollution Control Act, as amended (33 U.S.C. 1251-1387). Violations must be reported to the Federal Highway Administration and the Regional Office of the Environmental Protection Agency. 2 CFR Part 200, Appendix II.

The contractor agrees to include or cause to be included the requirements of this Section in every subcontract, and further agrees to take such action as the contracting agency may direct as a means of enforcing such requirements. 2 CFR 200.327.

**X. CERTIFICATION REGARDING DEBARMENT, SUSPENSION, INELIGIBILITY AND VOLUNTARY EXCLUSION**

This provision is applicable to all Federal-aid construction contracts, design-build contracts, subcontracts, lower-tier subcontracts, purchase orders, lease agreements, consultant contracts or any other covered transaction requiring FHWA approval or that is estimated to cost \$25,000 or more – as defined in 2 CFR Parts 180 and 1200. 2 CFR 180.220 and 1200.220.

**1. Instructions for Certification – First Tier Participants:**

- a. By signing and submitting this proposal, the prospective first tier participant is providing the certification set out below.
- b. The inability of a person to provide the certification set out below will not necessarily result in denial of participation in this covered transaction. The prospective first tier participant shall submit an explanation of why it cannot provide the certification set out below. The certification or explanation will be considered in connection with the department or agency's determination whether to enter into this transaction. However, failure of the prospective first tier participant to furnish a certification or an explanation shall disqualify such a person from participation in this transaction. 2 CFR 180.320.
- c. The certification in this clause is a material representation of fact upon which reliance was placed when the contracting agency determined to enter into this transaction. If it is later determined that the prospective participant knowingly rendered an erroneous certification, in addition to other remedies available to the Federal Government, the contracting agency may terminate this transaction for cause of default. 2 CFR 180.325.
- d. The prospective first tier participant shall provide immediate written notice to the contracting agency to whom this proposal is submitted if any time the prospective first tier participant learns that its certification was erroneous when submitted or has become erroneous by reason of changed circumstances. 2 CFR 180.345 and 180.350.

e. The terms "covered transaction," "debarred," "suspended," "ineligible," "participant," "person," "principal," and "voluntarily excluded," as used in this clause, are defined in 2 CFR Parts 180, Subpart I, 180.900-180.1020, and 1200. "First Tier Covered Transactions" refers to any covered transaction between a recipient or subrecipient of Federal funds and a participant (such as the prime or general contract). "Lower Tier Covered Transactions" refers to any covered transaction under a First Tier Covered Transaction (such as subcontracts). "First Tier Participant" refers to the participant who has entered into a covered transaction with a recipient or subrecipient of Federal funds (such as the prime or general contractor). "Lower Tier Participant" refers any participant who has entered into a covered transaction with a First Tier Participant or other Lower Tier Participants (such as subcontractors and suppliers).

f. The prospective first tier participant agrees by submitting this proposal that, should the proposed covered transaction be entered into, it shall not knowingly enter into any lower tier covered transaction with a person who is debarred, suspended, declared ineligible, or voluntarily excluded from participation in this covered transaction, unless authorized by the department or agency entering into this transaction. 2 CFR 180.330.

g. The prospective first tier participant further agrees by submitting this proposal that it will include the clause titled "Certification Regarding Debarment, Suspension, Ineligibility and Voluntary Exclusion-Lower Tier Covered Transactions," provided by the department or contracting agency, entering into this covered transaction, without modification, in all lower tier covered transactions and in all solicitations for lower tier covered transactions exceeding the \$25,000 threshold. 2 CFR 180.220 and 180.300.

h. A participant in a covered transaction may rely upon a certification of a prospective participant in a lower tier covered transaction that is not debarred, suspended, ineligible, or voluntarily excluded from the covered transaction, unless it knows that the certification is erroneous. 2 CFR 180.300; 180.320, and 180.325. A participant is responsible for ensuring that its principals are not suspended, debarred, or otherwise ineligible to participate in covered transactions. 2 CFR 180.335. To verify the eligibility of its principals, as well as the eligibility of any lower tier prospective participants, each participant may, but is not required to, check the System for Award Management website (<https://www.sam.gov/>). 2 CFR 180.300, 180.320, and 180.325.

i. Nothing contained in the foregoing shall be construed to require the establishment of a system of records in order to render in good faith the certification required by this clause. The knowledge and information of the prospective participant is not required to exceed that which is normally possessed by a prudent person in the ordinary course of business dealings.

j. Except for transactions authorized under paragraph (f) of these instructions, if a participant in a covered transaction knowingly enters into a lower tier covered transaction with a person who is suspended, debarred, ineligible, or voluntarily excluded from participation in this transaction, in addition to other remedies available to the Federal Government, the department or agency may terminate this transaction for cause or default. 2 CFR 180.325.

\* \* \* \* \*

**2. Certification Regarding Debarment, Suspension, Ineligibility and Voluntary Exclusion – First Tier Participants:**

a. The prospective first tier participant certifies to the best of its knowledge and belief, that it and its principals:

(1) Are not presently debarred, suspended, proposed for debarment, declared ineligible, or voluntarily excluded from participating in covered transactions by any Federal department or agency, 2 CFR 180.335;.

(2) Have not within a three-year period preceding this proposal been convicted of or had a civil judgment rendered against them for commission of fraud or a criminal offense in connection with obtaining, attempting to obtain, or performing a public (Federal, State, or local) transaction or contract under a public transaction; violation of Federal or State antitrust statutes or commission of embezzlement, theft, forgery, bribery, falsification or destruction of records, making false statements, or receiving stolen property, 2 CFR 180.800;

(3) Are not presently indicted for or otherwise criminally or civilly charged by a governmental entity (Federal, State or local) with commission of any of the offenses enumerated in paragraph (a)(2) of this certification, 2 CFR 180.700 and 180.800; and

(4) Have not within a three-year period preceding this application/proposal had one or more public transactions (Federal, State or local) terminated for cause or default. 2 CFR 180.335(d).

(5) Are not a corporation that has been convicted of a felony violation under any Federal law within the two-year period preceding this proposal (USDOT Order 4200.6 implementing appropriations act requirements); and

(6) Are not a corporation with any unpaid Federal tax liability that has been assessed, for which all judicial and administrative remedies have been exhausted, or have lapsed, and that is not being paid in a timely manner pursuant to an agreement with the authority responsible for collecting the tax liability (USDOT Order 4200.6 implementing appropriations act requirements).

b. Where the prospective participant is unable to certify to any of the statements in this certification, such prospective participant should attach an explanation to this proposal. 2 CFR 180.335 and 180.340.

\*\*\*\*\*

**3. Instructions for Certification - Lower Tier Participants:**

(Applicable to all subcontracts, purchase orders, and other lower tier transactions requiring prior FHWA approval or estimated to cost \$25,000 or more - 2 CFR Parts 180 and 1200). 2 CFR 180.220 and 1200.220.

a. By signing and submitting this proposal, the prospective lower tier participant is providing the certification set out below.

b. The certification in this clause is a material representation of fact upon which reliance was placed when this transaction was entered into. If it is later determined that the prospective lower tier participant knowingly rendered an erroneous certification, in addition to other remedies available to the Federal Government, the department, or agency with which

this transaction originated may pursue available remedies, including suspension and/or debarment.

c. The prospective lower tier participant shall provide immediate written notice to the person to which this proposal is submitted if at any time the prospective lower tier participant learns that its certification was erroneous by reason of changed circumstances. 2 CFR 180.365.

d. The terms "covered transaction," "debarred," "suspended," "ineligible," "participant," "person," "principal," and "voluntarily excluded," as used in this clause, are defined in 2 CFR Parts 180, Subpart I, 180.900 – 180.1020, and 1200. You may contact the person to which this proposal is submitted for assistance in obtaining a copy of those regulations. "First Tier Covered Transactions" refers to any covered transaction between a recipient or subrecipient of Federal funds and a participant (such as the prime or general contract). "Lower Tier Covered Transactions" refers to any covered transaction under a First Tier Covered Transaction (such as subcontracts). "First Tier Participant" refers to the participant who has entered into a covered transaction with a recipient or subrecipient of Federal funds (such as the prime or general contractor). "Lower Tier Participant" refers any participant who has entered into a covered transaction with a First Tier Participant or other Lower Tier Participants (such as subcontractors and suppliers).

e. The prospective lower tier participant agrees by submitting this proposal that, should the proposed covered transaction be entered into, it shall not knowingly enter into any lower tier covered transaction with a person who is debarred, suspended, declared ineligible, or voluntarily excluded from participation in this covered transaction, unless authorized by the department or agency with which this transaction originated. 2 CFR 1200.220 and 1200.332.

f. The prospective lower tier participant further agrees by submitting this proposal that it will include this clause titled "Certification Regarding Debarment, Suspension, Ineligibility and Voluntary Exclusion-Lower Tier Covered Transaction," without modification, in all lower tier covered transactions and in all solicitations for lower tier covered transactions exceeding the \$25,000 threshold. 2 CFR 180.220 and 1200.220.

g. A participant in a covered transaction may rely upon a certification of a prospective participant in a lower tier covered transaction that is not debarred, suspended, ineligible, or voluntarily excluded from the covered transaction, unless it knows that the certification is erroneous. A participant is responsible for ensuring that its principals are not suspended, debarred, or otherwise ineligible to participate in covered transactions. To verify the eligibility of its principals, as well as the eligibility of any lower tier prospective participants, each participant may, but is not required to, check the System for Award Management website (<https://www.sam.gov/>), which is compiled by the General Services Administration. 2 CFR 180.300, 180.320, 180.330, and 180.335.

h. Nothing contained in the foregoing shall be construed to require establishment of a system of records in order to render in good faith the certification required by this clause. The knowledge and information of participant is not required to exceed that which is normally possessed by a prudent person in the ordinary course of business dealings.

i. Except for transactions authorized under paragraph e of these instructions, if a participant in a covered transaction knowingly enters into a lower tier covered transaction with a person who is suspended, debarred, ineligible, or voluntarily

excluded from participation in this transaction, in addition to other remedies available to the Federal Government, the department or agency with which this transaction originated may pursue available remedies, including suspension and/or debarment. 2 CFR 180.325.

\*\*\*\*\*

#### **4. Certification Regarding Debarment, Suspension, Ineligibility and Voluntary Exclusion--Lower Tier Participants:**

a. The prospective lower tier participant certifies, by submission of this proposal, that neither it nor its principals:

(1) is presently debarred, suspended, proposed for debarment, declared ineligible, or voluntarily excluded from participating in covered transactions by any Federal department or agency, 2 CFR 180.355;

(2) is a corporation that has been convicted of a felony violation under any Federal law within the two-year period preceding this proposal (USDOT Order 4200.6 implementing appropriations act requirements); and

(3) is a corporation with any unpaid Federal tax liability that has been assessed, for which all judicial and administrative remedies have been exhausted, or have lapsed, and that is not being paid in a timely manner pursuant to an agreement with the authority responsible for collecting the tax liability. (USDOT Order 4200.6 implementing appropriations act requirements)

b. Where the prospective lower tier participant is unable to certify to any of the statements in this certification, such prospective participant should attach an explanation to this proposal.

\*\*\*\*\*

#### **XI. CERTIFICATION REGARDING USE OF CONTRACT FUNDS FOR LOBBYING**

This provision is applicable to all Federal-aid construction contracts and to all related subcontracts which exceed \$100,000. 49 CFR Part 20, App. A.

1. The prospective participant certifies, by signing and submitting this bid or proposal, to the best of his or her knowledge and belief, that:

a. No Federal appropriated funds have been paid or will be paid, by or on behalf of the undersigned, to any person for influencing or attempting to influence an officer or employee of any Federal agency, a Member of Congress, an officer or employee of Congress, or an employee of a Member of Congress in connection with the awarding of any Federal contract, the making of any Federal grant, the making of any Federal loan, the entering into of any cooperative agreement, and the extension, continuation, renewal, amendment, or modification of any Federal contract, grant, loan, or cooperative agreement.

b. If any funds other than Federal appropriated funds have been paid or will be paid to any person for influencing or attempting to influence an officer or employee of any Federal agency, a Member of Congress, an officer or employee of Congress, or an employee of a Member of Congress in connection with this Federal contract, grant, loan, or

cooperative agreement, the undersigned shall complete and submit Standard Form-LLL, "Disclosure Form to Report Lobbying," in accordance with its instructions.

2. This certification is a material representation of fact upon which reliance was placed when this transaction was made or entered into. Submission of this certification is a prerequisite for making or entering into this transaction imposed by 31 U.S.C. 1352. Any person who fails to file the required certification shall be subject to a civil penalty of not less than \$10,000 and not more than \$100,000 for each such failure.

3. The prospective participant also agrees by submitting its bid or proposal that the participant shall require that the language of this certification be included in all lower tier subcontracts, which exceed \$100,000 and that all such recipients shall certify and disclose accordingly.

#### **XII. USE OF UNITED STATES-FLAG VESSELS:**

This provision is applicable to all Federal-aid construction contracts, design-build contracts, subcontracts, lower-tier subcontracts, purchase orders, lease agreements, or any other covered transaction. 46 CFR Part 381.

This requirement applies to material or equipment that is acquired for a specific Federal-aid highway project. 46 CFR 381.7. It is not applicable to goods or materials that come into inventories independent of an FHWA funded-contract.

When oceanic shipments (or shipments across the Great Lakes) are necessary for materials or equipment acquired for a specific Federal-aid construction project, the bidder, proposer, contractor, subcontractor, or vendor agrees:

1. To utilize privately owned United States-flag commercial vessels to ship at least 50 percent of the gross tonnage (computed separately for dry bulk carriers, dry cargo liners, and tankers) involved, whenever shipping any equipment, material, or commodities pursuant to this contract, to the extent such vessels are available at fair and reasonable rates for United States-flag commercial vessels. 46 CFR 381.7.

2. To furnish within 20 days following the date of loading for shipments originating within the United States or within 30 working days following the date of loading for shipments originating outside the United States, a legible copy of a rated, 'on-board' commercial ocean bill-of-lading in English for each shipment of cargo described in paragraph (b)(1) of this section to both the Contracting Officer (through the prime contractor in the case of subcontractor bills-of-lading) and to the Office of Cargo and Commercial Sealift (MAR-620), Maritime Administration, Washington, DC 20590. (MARAD requires copies of the ocean carrier's (master) bills of lading, certified onboard, dated, with rates and charges. These bills of lading may contain business sensitive information and therefore may be submitted directly to MARAD by the Ocean Transportation Intermediary on behalf of the contractor). 46 CFR 381.7.

**ATTACHMENT A - EMPLOYMENT AND MATERIALS  
PREFERENCE FOR APPALACHIAN DEVELOPMENT  
HIGHWAY SYSTEM OR APPALACHIAN LOCAL ACCESS  
ROAD CONTRACTS (23 CFR 633, Subpart B, Appendix B)**

This provision is applicable to all Federal-aid projects funded under the Appalachian Regional Development Act of 1965.

1. During the performance of this contract, the contractor undertaking to do work which is, or reasonably may be, done as on-site work, shall give preference to qualified persons who regularly reside in the labor area as designated by the DOL wherein the contract work is situated, or the subregion, or the Appalachian counties of the State wherein the contract work is situated, except:

a. To the extent that qualified persons regularly residing in the area are not available.

b. For the reasonable needs of the contractor to employ supervisory or specially experienced personnel necessary to assure an efficient execution of the contract work.

c. For the obligation of the contractor to offer employment to present or former employees as the result of a lawful collective bargaining contract, provided that the number of nonresident persons employed under this subparagraph (1c) shall not exceed 20 percent of the total number of employees employed by the contractor on the contract work, except as provided in subparagraph (4) below.

2. The contractor shall place a job order with the State Employment Service indicating (a) the classifications of the laborers, mechanics and other employees required to perform the contract work, (b) the number of employees required in each classification, (c) the date on which the participant estimates such employees will be required, and (d) any other pertinent information required by the State Employment Service to complete the job order form. The job order may be placed with the State Employment Service in writing or by telephone. If during the course of the contract work, the information submitted by the contractor in the original job order is substantially modified, the participant shall promptly notify the State Employment Service.

3. The contractor shall give full consideration to all qualified job applicants referred to him by the State Employment Service. The contractor is not required to grant employment to any job applicants who, in his opinion, are not qualified to perform the classification of work required.

4. If, within one week following the placing of a job order by the contractor with the State Employment Service, the State Employment Service is unable to refer any qualified job applicants to the contractor, or less than the number requested, the State Employment Service will forward a certificate to the contractor indicating the unavailability of applicants. Such certificate shall be made a part of the contractor's permanent project records. Upon receipt of this certificate, the contractor may employ persons who do not normally reside in the labor area to fill positions covered by the certificate, notwithstanding the provisions of subparagraph (1c) above.

5. The provisions of 23 CFR 633.207(e) allow the contracting agency to provide a contractual preference for the use of mineral resource materials native to the Appalachian region.

6. The contractor shall include the provisions of Sections 1 through 4 of this Attachment A in every subcontract for work which is, or reasonably may be, done as on-site work.

**FEDERAL AID PROVISIONS**

**December 1980**

**NOTICE OF REQUIREMENT FOR AFFIRMATIVE ACTION TO ENSURE  
 EQUAL EMPLOYMENT OPPORTUNITY (EXECUTIVE ORDER 11246)**

1. The Offeror's or Bidders attention is called to the "Equal Opportunity Clause" and the Standard Federal Equal Employment Opportunity Construction Contract Specifications" set forth therein.
2. The goals and timetables for minority and female participation, expressed in percentage terms for the Contractor's aggregate workforce in each trade on all construction work in the covered area, are as follows:
3. Construction contractors which are participating in an approved Hometown Plan (see 41 CFR 60-4.5) are required to comply with the goals of the Hometown Plan with regard to construction work they perform in the area covered by the Hometown Plan. With regard to all their covered construction work, such contractors are required to comply with the following goals:

Goals for Female participation for each trade

AREA COVERED

Goals for women apply nationwide

GOALS AND TIMETABLES

**Goals**

Timetable	(Percent)
From April 1, 1978 until March 31, 1979	3.1
From April 1, 1979 until March 31, 1980	5.1
From April 1, 1980 until March 31, 1981	6.9

**Goals for Minority Participation for Each Trade**

**County                                      Goal (Percent)                                      County                                      Goal (Percent)**

Adair	4	Linn	4
Andrew	3.2	Livingston	10
Atchison	10	McDonald	2.3
Audrain	4	Macon	4
Barry	2.3	Madison	11.4
Barton	2.3	Maries	11.4
Bates	10	Marion	3.1
Benton	10	Mercer	10
Bollinger	11.4	Miller	4
Boone	6.3	Mississippi	11.4
Buchanan	3.2	Moniteau	4
Butler	11.4	Monroe	4
Caldwell	10	Montgomery	11.4
Callaway	4	Morgan	4
Camden	4	New Madrid	26.5
Cape Girardeau	11.4	Newton	2.3
Carroll	10	Nodaway	10

TAP 9901(313) and 16696  
Business 50W  
Cole County

Carter	11.4	Oregon	2.3
Cass	12.7	Osage	4
Cedar	2.3	Ozark	2.3
Chariton	4	Pemiscot	26.5
Christian	2	Perry	11.4
Clark	3.4	Pettis	10
Clay	12.7	Phelps	11.4
Clinton	10	Pike	3.1
Cole	4	Platte	12.7
Cooper	4	Polk	2.3
Crawford	11.4	Pulaski	2.3
Dade	2.3	Putnam	4
Dallas	2.3	Ralls	3.1
Daviess	10	Randolph	4
DeKalb	10	Ray	12.7
Dent	11.4	Reynolds	11.4
Douglas	2.3	Ripley	11.4
Dunklin	26.5	St. Charles	14.7
Franklin	14.7	St. Clair	2.3
Gasconade	11.4	St. Francois	11.4
Gentry	10	Ste. Genevieve	11.4
Greene	2	St. Louis City	14.7
Grundy	10	St. Louis County	14.7
Harrison	10	Saline	10
Henry	10	Schuylar	4
Hickory	2.3	Scotland	4
Holt	10	Scott	11.4
Howard	4	Shannon	2.3
Howell	2.3	Shelby	4
Iron	11.4	Stoddard	11.4
Jackson	12.7	Stone	2.3
Jasper	2.3	Sullivan	4
Jefferson	14.7	Taney	2.3
Johnson	10	Texas	2.3
Knox	4	Vernon	2.3
Laclede	2.3	Warren	11.4
Lafayette	10	Washington	11.4
Lawrence	2.3	Wayne	11.4
Lewis	3.1	Webster	2.3
Lincoln	11.4	Worth	10
		Wright	2.3

These goals are applicable to all of the contractor's construction work (whether or not is Federal or federally assisted) performed in the covered area. If the contractor performs construction work in a geographical area located outside of the covered area, it shall apply the goals established for such geographical area where the work is actually performed. With regard to this second area, the contractor also is subject to the goals for both its federally involved and nonfederally involved construction.

The Contractor's compliance with the Executive Order and the regulations in 41 CFR Part 60-4 shall be based on Its Implementation of the Equal Opportunity Clause, specific affirmative action obligations required by the specifications set forth in 41 CFR 60-4.3(a), and its effort to meet the goals. The hours of minority and female employment and training must be substantially uniform throughout the length of the contract, and in each trade, and the Contractor shall make a good faith effort to employ minorities and women evenly on each of its projects. The transfer of minority, or female employees or trainees from Contractor to Contractor or



from project to project for the sole purpose of meeting the Contractor's goals shall be a violation of the contract, the Executive Order and the regulations in 41 CFR Part 60-4. Compliance with the goals will be measured against the total work hours performed.

4. The Contractor shall provide written notification to the Director of the Office of Federal Contract Compliance Programs within 10 working days of award of any construction subcontract in excess of \$10,000 at any tier for construction work under the contract resulting from this solicitation. The notification shall list the name, address and telephone number of the subcontractor; employer identification number; estimated dollar amount of the subcontract; estimated starting and completion dates of the subcontract; and the geographical area in which the subcontract is to be performed.
5. As used in this Notice, and in the contract resulting from this solicitation, the "covered area" of the county, route and limits described in the proposal for the work.

July 1986

**STANDARD FEDERAL EQUAL EMPLOYMENT OPPORTUNITY CONSTRUCTION**  
**CONTRACT SPECIFICATIONS (EXECUTIVE ORDER 11246)**

1. As used in these specifications:
  - a. "Covered area" means the geographical area described in the solicitation which this contract resulted.
  - b. "Director" mean Director, Office of Federal Contract Compliance Programs, United States Department of labor, or any person to who the Director delegates authority;
  - c. "Employer Identification Number" means the Federal Social Security number used on the Employer's quarterly Federal Tax Return, U.S. Treasury Department Form 941;
  - d. "Minority" includes;
    - (i) Black (all persons having origins in any of the Black African racial groups not of Hispanic origin);
    - (ii) Hispanic (all persons of Mexican, Puerto Rican, Cuban, Central or South American or other Spanish Culture or origin, regardless of race);
    - (iii) Asian and pacific islander (all persons having origins in any of the original peoples of the Far East, southeast Asia, the Indian Subcontinent, or the Pacific Islands; and
    - (iv) American Indian or Alaskan Native (all persons having origins in any of the original peoples of North American and maintain identifiable affiliations through membership and participation or community identifications.
2. Whenever the Contractor, or any Subcontractor at any tier, subcontractors a portion of the work involving any construction trade, it shall physically include in each subcontract in excess of \$10,000 the provisions of these specifications and the Notice which contains the applicable goals for minority and female participation and which is set forth in the solicitations from which this contract resulted.
3. If the Contract is participating (pursuant to 41 CFR 60-4.5) in a Hometown Plan approved by the U.S. Department of Labor in the covered area either individually or through the association, its affirmative action obligations on all work in the Plan area (including goals and timetables) shall be in accordance with the Plan for those trades which have unions participating in the Plan. Contractors must be able to demonstrate their participation in and compliance with the provisions of any such Hometown Plan. Each Contractor or Subcontractor participating in an approved Plan is individually required to comply with its obligation under the EEO clause, and to make a good faith effort to achieve each goal under the Plan in each trade in which it has employees. The overall good faith performance by other Contractors or Subcontractors toward a goal in

an approved Plan does not excuse any covered Contractor's or Subcontractors' failure to take good faith efforts to achieve the Plan goals and timetables.

4. The Contractor shall implement the specific affirmative action standards provided in paragraphs 7a through 7p of these specifications. The goals set forth in the solicitation from which this contact resulted are expressed as percentages of the total hours of employment and training of minority and female utilization the Contractor should reasonably be able to achieve in each construction trade in which it has employees in the covered area. Covered Construction contractors performing construction work in geographical areas where they do not have a Federal or federally assisted construction contract shall apply the minority and female goals established for the geographical area where the work is being performed. Goals are published periodically in the Federal Register in notice form, and such notices may be obtained from any Office of Federal Contract Compliance Programs office or from Federal procurement contracting officers. The Contractor is expected to make substantially uniform progress toward its goals in each craft during the period specified.
5. Neither the provisions of any collective bargaining agreement, nor the failure by a union with who the Contractor has a collective bargaining agreement, to refer either minorities or women shall excuse the Contractor's obligations under these specifications, Executive Order 11246, or the regulations promulgated pursuant thereto.
6. In order for the nonworking training hours or apprentices and trainees to be counted in meeting the goal, such apprentices and trainees must be employed by the Contractor during the training period, and the Contractor must have made a commitment to employ the apprentices and trainees at the completion of their training, subject to the availability of employment opportunities. Trainees must be trained pursuant to training programs approved by the U.S. Department of Labor.
7. The contractor shall take specific affirmative actions to ensure equal employment opportunity. The evaluation of the Contractor's compliance with these specifications shall be used its effort to achieve maximum results from its actions. The Contractor shall document these efforts fully, and shall implement affirmative action steps at least as extensive as the following:
  - a. Ensure and maintain a working environment free of harassment, intimidation, and coercion at all sites, and all facilities at which the Contractor's employees are assigned to work. The Contractor shall specifically ensure that all foremen, superintendents, and other on-site supervisory personnel are aware of and carry out the Contractor's obligation to maintain such a working environment, with specific attention to minority or female individuals working at such sites or in such facilities.
  - b. Establish and maintain a current list of minority and female recruitment sources, provide written notification to minority and female recruitment sources and to community organizations when the Contractor or its unions have employment opportunities available, and maintain a record of the organizations' responses.
  - c. Maintain a current file or the names, addresses and telephone numbers of each minority and female off-the-street applicant and minority or female referral from a union, a recruitment source or community organization and what action was taken with respect to each such individual. If such individual was sent to the union hiring hall for referral and was not referred back to the Contractor by the union or, if referred not employed by the contractor, this shall be documented in the file with the reason therefore, along with whatever additional actions the Contractor may have taken.
  - d. Provide immediate written notification to the Director when the union or unions with which the Contractor has as collective bargaining agreement has not referred to the contractor a minority

person or woman sent by the Contractor, or when the Contractor has other information that the union referral process has impeded the Contractor's efforts to meet its obligations.

- e. Develop on-the-job training opportunities and/or participate in training programs for the area which expressly include minorities and women, including upgrading programs and apprenticeship and trainee programs relevant of the contractor's employment needs, especially those programs funded or approved by the Department of Labor. The contractor shall provide notice of these programs to the sources compiled under 7b above.
- f. Disseminate the Contractor's EEO policy by providing notice of the policy to unions and training programs and requesting their cooperation in assisting the Contractor in meeting its EEO obligations; by including it in any policy manual and collective bargaining agreement by publicizing it in the company newspaper, annual report, etc., by specific review of the policy with all management personnel and with all minority and female employees at least one a year; and by posting the company EEO policy on bulletin boards accessible to all employees at each location where construction work is performed.
- g. Review, at least annually, the company's EEO policy and affirmative action obligations under these specifications with all employees having any responsibility for hiring, assignment, layoff, termination or other employment decisions including specific review of these items with on-site supervisory personnel such as superintendents, General foreman, etc., prior to the initiation of construction work at any job site. A written record shall be made and maintained identifying the time and place of these meetings, person attending, subject matter discussed, and the disposition of the subject matter.
- h. Disseminate the Contractor's EEO policy externally by including it in any advertising in the news media, specifically including minority and female news media and providing written notification to and discussing the contractor's EEO policy with other Contractors and Subcontractors with who the Contractor does or anticipates doing business.
- i. Direct is a recruitment effort, both oral and written, to minority female and community organizations, to schools with minority and female students and to minority and female recruitment and training organizations serving the Contractor's recruitment area and employment needs. Not later than one month prior to the date for the acceptance or applicants for apprenticeship or other training by any recruitment source, the Contractor shall send written notification to organizations such as the above, describing the openings, screening procedures, and test to be used in the selection process.
- j. Encourage present minority and female employees to recruit other minority persons and women and, where reasonable, provide after school, summer vacations employment to minority and female youth both on the site and in other areas or contractor's workforce.
- k. Validate all tests and other selection requirements where there is an obligation to do so under 41 CFR Part 60-3.
- l. Conduct, at least annually, an inventory and evaluation at least of all minority and female personnel for promotional opportunities and encourage these employees to seek or to prepare for, through appropriate training, etc. such opportunities.
- m. Ensure that seniority practices, job classifications, work assignments and other personnel practices, do not have a discriminatory effect by continually monitoring all personnel and employment related activities to ensure that the EEO policy and the Contractor's obligation under these specifications are being carried out.

- n. Ensure that all facilities and company activities are non-segregated except that separate or single-user toilet and necessary changing facilities shall be provided to assure privacy between the sexes.
  - o. Document and maintain a record of all solicitations or offers for subcontracts from minority and female construction contractors and suppliers, including circulation of solicitations to minority and female contractor associations and other business associations.
  - p. Conduct a review, at least annually, of all supervisors' adherence to and performance under the Contractor's EEO policies and affirmative action obligations.
8. Contractors are encouraged to participate in voluntary associations which assist in fulfilling one or more of their affirmative action obligations (7a through 7p). The efforts of a contractor association, joint contractor union, contractor community, or other similar group of which the contractor is a member and participant, may be asserted as fulfilling anyone or more of its obligations under 7a through 7p of these specifications provided that the contractor actively participates in the group, makes every effort to assure that the group has a positive impact on the employment of minorities and women in the industry, ensures that the concrete benefits of the program are reflected in the contractor's minority and female workforce participation, makes a good faith effort to meet its individual goals and timetables, and can provide access to documentation which demonstrates the effectiveness of actions taken on behalf of the contractor. The obligation to comply, however, is the Contractor's and failure of such a group to fulfill an obligation shall not be a defense for the Contractor's noncompliance.
9. A single goal for minorities and a separate single goal for women have been established to provide equal employment opportunity and to take affirmative action for all minority groups, both male and female, and all women, both minority and non-minority. Consequently, the group is employed in a substantially disparate manner (for example, even though the Contractor has achieved its goals for women generally, the Contractor may be in violation of the executive order if a specific minority group of women is underutilized).
10. The Contractor shall not use the goals and timetables or affirmative action standards to discriminate against any person because of race, color, religion, sex, or national origin.
11. The Contractor shall not enter into any Subcontract with any person or firm debarred from Government contract pursuant to Executive Order 11246.
12. The Contractor shall carry out such sanctions and penalties for violation of these specifications and of the Equal Opportunity Clause, including suspension, termination and cancellation of existing subcontracts as may be imposed or ordered pursuant to Executive Order 11246, as amended, and its implementing regulations, by the Office of Federal Contract Compliance Programs. Any Contractor who fails to carry out such sanctions and penalties shall be in violation of these specifications and Executive Order 11246, as amended.
13. The Contractor, in fulfilling its obligations under these specifications, shall implement specific affirmative action steps, at least as extensive as those standards prescribed in paragraph 7 of these specifications, so as to achieve maximum results from its efforts to ensure equal employment opportunity. If the Contractor fails to comply with the requirements of the Executive Order, the implementing regulations, or these specifications, the Direct shall proceed in accordance with 41 CFR 60-4.8.
14. The Contractor shall designate a responsible official to monitor all employment related activity to ensure that the company EEO policy is being carried out to submit reports relating to the provisions hereof as may be required by the Government and to keep records. Records shall at least include for each employee the name, address, telephone numbers, construction trade, union affiliation if any, employee identification number when assigned, social security number, race, sex, status, (e.g. mechanic, apprentice, trainee, helper, or laborer), dates of changes in status, hours worked per week in the indicated trade, rat of pay, and locations at which the work was performed. Records shall be maintained in an easily understandable and retrievable

form; however, to the degree that existing records satisfy this requirement, contractors shall not be required to maintain separate records.

15. Nothing herein provided shall be constructed as a limitation upon the application of other laws which establish different standard of compliance or upon the application of requirements for the hiring of local or other area residents (e.g. those under the Public Works Employment Action of 1977 and the Community Development Block Grant Program.

#### **OPERATING POLICY STATEMENT**

The contractor shall accept as his operating policy the following statement, or one of equal coverage, which is designed to further the provision of equal employment opportunity to all persons without regard to their race, color, religion, sex, or national origin, and to promote the full realization of equal employment opportunity through a positive continuing program.

“It is the policy of this company to assure that applicants are employed, and that employees are treated during employment without regard to their race, religion, sex, color, or national origin. Such action shall include: employment, upgrading, demotion, or transfer, recruitment or recruitment advertising; layoff or termination; rates of pay or other forms of compensation; and selection for training, including apprenticeship, pre-apprenticeship, and/or on-the-job training.”

#### **SUPPLEMENTAL REPORTING REQUIREMENTS**

- A. The Contractor will keep such records as are necessary to determine compliance with the contractor’s equal employment opportunity obligations. The records kept by the contractor will be designed to indicate the number of minority and non-minority group members and women employed in each work classification on the project.
- B. All such records must be retained for a period of three years following completion of the contract work and shall be available at reasonable times and places for inspection by authorized representatives of the State Highway Agency and the Federal Highway Administration.
- C. The contractor and each covered subcontractor will submit to the State Highway Agency, for the month of July, for the duration of the project, a report (Form PR-1391) “Federal-Aid Highway Construction Contractors Annual EEO Report”, indicating the number of minority, women and non-minority group employees currently engaged in each work classification required by the contract work.

#### **NONDISCRIMINATION IN EMPLOYMENT**

**July 1990**

The following provisions are added by the State to the Required Contract Provisions of Federal-Aid Contracts.

The contractor is advised that the exemptions referred to in the Required Contract Provisions, Federal-Aid contracts under Section II, Nondiscrimination, Paragraph 3g, with respect to contracts and subcontracts, are substantial and are to be found in Chapter 60, Office of Federal Contract Compliance, Equal Employment Opportunity, Department of Labor (33 Federal Register 7804-7812, May 28, 1968, effective July 1, 1968, Chapter 60, Title 41, Code of Federal Regulations), by which contracts and subcontracts of \$10,000 or less and certain contracts and subcontracts for indefinite quantities are exempt.

The two pertinent exemption clauses are as follows:

60-1.5 Exemptions

- (a) General – (1) Transactions of \$10,000 or under. Contracts and Subcontractors not exceeding \$10,000, other than Government bills of lading, and other than contract and subcontracts with depositories of Federal funds in any amount and with financial institutions which are issuing and paying agents for U.S. savings bonds and savings notes, are exempt from the requirements of the equal opportunity clause. In determining the applicability of this exemption to any federally assisted construction contract, or subcontract thereunder, the amount of such contract or subcontract rather than the amount of the Federal financial assistance shall govern. No agency, contractor, or subcontractor shall procure supplies or services in a manner so as to avoid applicability of the equal opportunity clause: Provided, that where a contractor has contracts or subcontracts with the Government in any 12-month period which have an aggregate total value (or can reasonably be expected to have an aggregate total value) exceeding \$10,000, the \$10,000 or under exemption does not apply, and the contracts are subject to the order and the regulation issued pursuant thereto regardless of whether any single contracts exceeds \$10,000.

# Missouri

## Division of Labor Standards

### WAGE AND HOUR SECTION

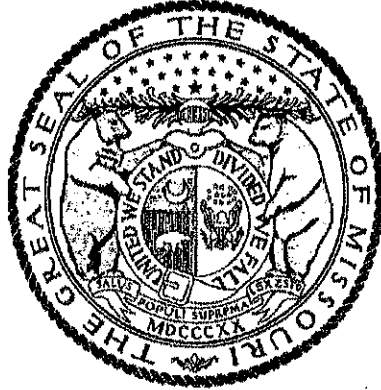

MIKE KEHOE, Governor

# Annual Wage Order No. 32

Section 026  
**COLE COUNTY**

In accordance with Section 290.262 RSMo 2000, within thirty (30) days after a certified copy of this Annual Wage Order has been filed with the Secretary of State as indicated below, any person who may be affected by this Annual Wage Order may object by filing an objection in triplicate with the Labor and Industrial Relations Commission, P.O. Box 599, Jefferson City, MO 65102-0599. Such objections must set forth in writing the specific grounds of objection. Each objection shall certify that a copy has been furnished to the Division of Labor Standards, P.O. Box 449, Jefferson City, MO 65102-0449 pursuant to 8 CSR 20-5.010(1). A certified copy of the Annual Wage Order has been filed with the Secretary of State of Missouri.

Original Signed by \_\_\_\_\_

Logan Hobbs, Director  
Division of Labor Standards

Filed With Secretary of State: \_\_\_\_\_ **March 10, 2025**

Last Date Objections May Be Filed: **April 9, 2025**

Prepared by Missouri Department of Labor and Industrial Relations

OCCUPATIONAL TITLE	**Prevailing Hourly Rate
Asbestos Worker	\$64.96
Boilermaker	\$32.28*
Bricklayer-Stone Mason	\$32.28*
Carpenter	\$54.62
Lather	
Linoleum Layer	
Millwright	
Pile Driver	
Cement Mason	\$32.28*
Plasterer	
Communication Technician	\$61.08
Electrician (Inside Wireman)	\$61.85
Electrician Outside Lineman	\$82.94
Lineman Operator	
Lineman - Tree Trimmer	
Groundman	
Groundman - Tree Trimmer	
Elevator Constructor	\$32.28*
Glazier	\$49.32
<b>Ironworker</b>	<b>\$85.05</b>
Laborer	\$44.70
General Laborer	
First Semi-Skilled	
Second Semi-Skilled	
Mason	\$62.12
Marble Mason	
Marble Finisher	
Terrazzo Worker	
Terrazzo Finisher	
Tile Setter	
Tile Finisher	
Operating Engineer	\$68.28
Group I	
Group II	
Group III	
Group III-A	
Group IV	
Group V	
Painter	\$43.73
Plumber	\$73.50
Pipe Fitter	
Roofer	\$55.60
Sheet Metal Worker	\$60.62
Sprinkler Fitter	\$69.41
Truck Driver	\$32.28*
Truck Control Service Driver	
Group I	
Group II	
Group III	
Group IV	

\*The Division of Labor Standards received fewer than 1,000 reportable hours for this occupational title. The public works contracting minimum wage is established for this occupational title using data provided by Missouri Economic Research and Information Center.

\*\*The Prevailing Hourly Rate includes any applicable fringe benefit amounts for each occupational title as defined in RSMo Section 290.210.



Heavy Construction Rates for  
COLE County

Section 026

OCCUPATIONAL TITLE	**Prevailing Hourly Rate
Carpenter	\$57.08
Millwright	
Pile Driver	
Electrician (Outside Lineman)	\$82.94
Lineman Operator	
Lineman - Tree Trimmer	
Groundman	
Groundman - Tree Trimmer	
Laborer	\$52.43
General Laborer	
Skilled Laborer	
Operating Engineer	\$69.38
Group I	
Group II	
Group III	
Group IV	
Truck Driver	\$32.28*
Truck Control Service Driver	
Group I	
Group II	
Group III	
Group IV	

Use Heavy Construction Rates on Highway and Heavy construction in accordance with the classifications of construction work established in 8 CSR 30-3.040(3).

Use Building Construction Rates on Building construction in accordance with the classifications of construction work established in 8 CSR 30-3.040(2).

If a worker is performing work on a heavy construction project within an occupational title that is not listed on the Heavy Construction Rate Sheet, use the rate for that occupational title as shown on the Building Construction Rate Sheet.

\*The Division of Labor Standards received fewer than 1,000 reportable hours for this occupational title. Public works contracting minimum wage is established for this occupational title using data provided by Missouri Economic Research and Information Center.

\*\*The Prevailing Hourly Rate includes any applicable fringe benefit amounts for each occupational title.

# OVERTIME and HOLIDAYS

## OVERTIME

For all work performed on a Sunday or a holiday, not less than twice (2x) the prevailing hourly rate of wages for work of a similar character in the locality in which the work is performed or the public works contracting minimum wage, whichever is applicable, shall be paid to all workers employed by or on behalf of any public body engaged in the construction of public works, exclusive of maintenance work.

For all overtime work performed, not less than one and one-half (1½) the prevailing hourly rate of wages for work of a similar character in the locality in which the work is performed or the public works contracting minimum wage, whichever is applicable, shall be paid to all workers employed by or on behalf of any public body engaged in the construction of public works, exclusive of maintenance work or contractual obligation. For purposes of this subdivision, "**overtime work**" shall include work that exceeds ten hours in one day and work in excess of forty hours in one calendar week; and

A thirty-minute lunch period on each calendar day shall be allowed for each worker on a public works project, provided that such time shall not be considered as time worked.

## HOLIDAYS

January first;  
The last Monday in May;  
July fourth;  
The first Monday in September;  
November eleventh;  
The fourth Thursday in November; and  
December twenty-fifth;

If any holiday falls on a Sunday, the following Monday shall be considered a holiday.

"General Decision Number: M020250001 09/05/2025

Superseded General Decision Number: M020240001

State: Missouri

Construction Types: Heavy and Highway

Counties: Missouri Statewide.

HEAVY AND HIGHWAY CONSTRUCTION PROJECTS

Note: Contracts subject to the Davis-Bacon Act are generally required to pay at least the applicable minimum wage rate required under Executive Order 14026 or Executive Order 13658. Please note that these Executive Orders apply to covered contracts entered into by the federal government that are subject to the Davis-Bacon Act itself, but do not apply to contracts subject only to the Davis-Bacon Related Acts, including those set forth at 29 CFR 5.1(a)(1).

If the contract is entered into on or after January 30, 2022, or the contract is renewed or extended (e.g., an option is exercised) on or after January 30, 2022:	<ul style="list-style-type: none"><li>. Executive Order 14026 generally applies to the contract.</li><li>. The contractor must pay all covered workers at least \$17.75 per hour (or the applicable wage rate listed on this wage determination, if it is higher) for all hours spent performing on the contract in 2025.</li></ul>
If the contract was awarded on or between January 1, 2015 and January 29, 2022, and the contract is not renewed or extended on or after January 30, 2022:	<ul style="list-style-type: none"><li>. Executive Order 13658 generally applies to the contract.</li><li>. The contractor must pay all covered workers at least \$13.30 per hour (or the applicable wage rate listed on this wage determination, if it is higher) for all hours spent performing on that contract in 2025.</li></ul>

The applicable Executive Order minimum wage rate will be adjusted annually. If this contract is covered by one of the

Executive Orders and a classification considered necessary for performance of work on the contract does not appear on this wage determination, the contractor must still submit a conformance request.

Additional information on contractor requirements and worker protections under the Executive Orders is available at <http://www.dol.gov/whd/govcontracts>.

Modification Number	Publication Date
0	01/03/2025
1	01/31/2025
2	02/07/2025
3	02/21/2025
4	04/11/2025
5	05/16/2025
6	06/13/2025
7	07/18/2025
8	08/15/2025
9	08/29/2025
10	09/05/2025

CARP0002-002 05/01/2024

ST. LOUIS COUNTY AND CITY

	Rates	Fringes
Carpenters.....	\$ 41.71	21.85

---

CARP0005-006 05/01/2024

CASS (Richards-Gebauer AFB ONLY), CLAY, JACKSON, PLATTE AND RAY COUNTIES

	Rates	Fringes
Carpenters:		
CARPENTERS & LATHERS.....	\$ 44.63	22.40
MILLWRIGHTS & PILEDRIVERS...	\$ 44.63	22.40

---

CARP0011-001 05/01/2024

	Rates	Fringes
Carpenter and Piledriver		
ADAIR, AUDRAIN (West of Hwy 19), BOONE, CALLAWAY,		

CHARITON, COLE, COOPER, HOWARD, KNOX, LINN, MACON, MILLER, MONITEAU, MONROE, OSAGE, PUTNAM, RANDOLPH, SCHUYLER, SHELBY AND SULLIVAN COUNTIES.....\$ 35.61	22.40
ATCHISON, ANDREW, BATES, CALDWELL, CARROLL, DAVIESS, DEKALB, GENTRY, GRUNDY, HARRISON, HENRY, HOLT, LIVINGSTON, MERCER, NODAWAY, ST. CLAIR, SALINE AND WORTH COUNTIES.....\$ 34.98	22.40
AUDRAIN (East of Hwy.19), RALLS, MARION, LEWIS, CLARK AND SCOTLAND COUNTIES.\$ 35.61	22.40
BARRY, BARTON, CAMDEN, CEDAR, CHRISTIAN, DADE, DALLAS, DOUGLAS, GREENE, HICKORY, JASPER, LACLEDE, LAWRENCE, MCDONALD, NEWTON, OZARK, POLK, STONE, TANEY, VERNON, WEBSTER AND WRIGHT COUNTIES.\$ 33.25	22.40
BENTON, MORGAN AND PETTIS...\$ 34.98	22.40
BOLLINGER, BUTLER, CAPE GIRARDEAU, DUNKLIN, MISSISSIPPI, NEW MADRID, PEMISCOT, PERRY, STE. GENEVIEVE, SCOTT, STODDARD AND WAYNE COUNTIES.....\$ 35.37	22.40
BUCHANAN, CLINTON, JOHNSON AND LAFAYETTE COUNTIES.....\$ 34.98	22.40
CARTER, HOWELL, OREGON AND RIPLEY COUNTIES.....\$ 34.04	22.40
CRAWFORD, DENT, GASCONADE, IRON, MADISON, MARIES, MONTGOMERY, PHELPS, PULASKI, REYNOLDS, SHANNON AND TEXAS COUNTIES.....\$ 35.37	22.40
FRANKLIN COUNTY.....\$ 42.19	22.40
JEFFERSON AND ST. CHARLES COUNTIES.....\$ 42.19	22.40
LINCOLN COUNTY.....\$ 38.04	22.40
PIKE, ST. FRANCOIS AND WASHINGTON COUNTIES.....\$ 36.13	22.40
WARREN COUNTY.....\$ 38.04	22.40

-----  
ELEC0001-002 06/02/2024

BOLLINGER, BUTLER, CAPE GIRARDEAU, CARTER, DUNKLIN, FRANKLIN,  
 IRON, JEFFERSON, LINCOLN, MADISON, MISSISSIPPI, NEW MADRID,  
 PEMISCOT, PERRY, REYNOLDS, RIPLEY, ST. CHARLES, ST. FRANCOIS,  
 ST. LOUIS (City and County), STE. GENEVIEVE, SCOTT, STODDARD,  
 WARREN, WASHINGTON AND WAYNE COUNTIES

	Rates	Fringes
Electricians.....	\$ 47.04	18.196

-----  
 ELEC0002-001 09/09/2024

ADAIR, AUDRAIN, BOONE, CALLAWAY, CAMDEN, CARTER, CHARITON,  
 CLARK, COLE, COOPER, CRAWFORD, DENT, FRANKLIN, GASCONADE,  
 HOWARD, HOWELL, IRON, JEFFERSON, KNOX, LEWIS, LINCON, LINN,  
 MACON, MARIES, MARION, MILLER, MONITEAU, MONROE, MONTGOMERY,  
 MORGAN, OREGON, OSAGE, PERRY, PHELPS, PIKE, PULASKI, PUTNAM,  
 RALLS, RANDOLPH, REYNOLDS, RIPLEY, ST. CHARLES, ST. FRANCOIS,  
 ST. LOUIS (City and County), STE. GENEVIEVE, SCHUYLER,  
 SCOTLAND, SHANNON, SHELBY, SULLIVAN, TEXAS, WARREN AND  
 WASHINGTON COUNTIES

	Rates	Fringes
Line Construction:		
Equipment Operator.....	\$ 47.77	24.68
Groundman & Truck Driver....	\$ 36.49	20.56
Lineman & Cable Splicer.....	\$ 55.65	27.56

-----  
 ELEC0053-005 01/01/2025

ANDREW, ATCHINSON, BARRY, BARTON, BATES, BENTON, BUCHANAN,  
 CALDWELL, CARROLL, CASS, CEDAR, CHRISTIAN, CLAY, CLINTON, DADE,  
 DALLAS, DAVIES, DEKALB, DOUGLAS, GENTRY, GREENE, GRUNDY,  
 HARRISON, HENRY, HICKORY, HOLT, LAFAYETTE, JACKSON, JASPER,  
 LACLEDE, LAWRENCE, LIVINGSTON, JOHNSON, MCDONALD, MERCER,  
 NEWTON, NODAWAY, OZARK, PETTIS, PLATTE, POLK, RAY, SALINE, ST.  
 CLAIR, STONE, TANEY, VERNON, WEBSTER, WORTH AND WRIGHT COUNTIES

	Rates	Fringes
Line Construction:		
Groundman Powderman.....	\$ 37.14	1.5%+19.76
Groundman.....	\$ 34.65	1.5%+18.93
Lineman Operator.....	\$ 52.45	1.5%+26.05
Lineman.....	\$ 56.18	1.5%+24.22

ELEC0095-001 06/01/2025

BARRY, BARTON, CEDAR, DADE, JASPER, LAWRENCE, MCDONALD, NEWTON,  
ST CLAIR, AND VERNON COUNTIES

	Rates	Fringes
Electricians:		
Cable Splicers.....	\$ 25.40	12.19
Electricians.....	\$ 32.25	20.81

-----  
ELEC0124-007 08/26/2024

BATES, BENTON, CARROLL, CASS, CLAY, COOPER, HENRY, JACKSON,  
JOHNSON, LAFAYETTE, MORGAN, PETTIS, PLATTE, RAY AND SALINE  
COUNTIES:

	Rates	Fringes
Electricians.....	\$ 51.01	26.25

-----  
ELEC0257-003 03/01/2025

AUDRAIN (Except Cuivre Township), BOONE, CALLAWAY, CAMDEN,  
CHARITON, COLE, CRAWFORD, DENT, GASCONADE, HOWARD, MARIES,  
MILLER, MONITEAU, OSAGE, PHELPS AND RANDOLPH COUNTIES

	Rates	Fringes
Electricians:		
Cable Splicers.....	\$ 30.42	16.085
Electricians.....	\$ 40.50	23.26

-----  
ELEC0350-002 12/01/2024

ADAIR, AUDRAIN (East of Highway 19), CLARK, KNOX, LEWIS, LINN,  
MACON, MARION, MONROE, MONTGOMERY, PIKE, PUTNAM, RALLS,  
SCHUYLER, SCOTLAND, SHELBY AND SULLIVAN COUNTIES

	Rates	Fringes
Electricians.....	\$ 37.60	22.145

-----  
ELEC0453-001 09/01/2024

	Rates	Fringes
--	-------	---------

Electricians:

CHRISITAN, DALLAS, DOUGLAS, GREENE, HICKORY, HOWELL, LACLEDE, OREGON, OZARK, POLK, SHANNON, WEBSTER and WRIGHT COUNTIES..\$ 32.40	19.11
PULASKI and TEXAS COUNTIES..\$ 39.70	19.84
STONE and TANEY COUNTIES....\$ 28.65	18.34

-----  
ELEC0545-003 06/01/2025

ANDREW, BUCHANAN, CLINTON, DEKALB, ATCHISON, HOLT, MERCER,  
GENTRY, HARRISON, DAVIESS, GRUNDY, WORTH, LIVINGSTON, NODAWAY,  
AND CALDWELL COUNTIES

	Rates	Fringes
Electricians:.....	\$ 43.20	21.50

-----  
ELEC0702-004 01/06/2025

BOLLINGER, BUTLER, CAPE GIRARDEAU, DUNKLIN, MADISON,  
MISSISSIPPI, NEW MADRID, PEMISCOT, SCOTT, STODDARD AND WAYNE  
COUNTIES

	Rates	Fringes
Line Construction:		
Groundman - Class A.....	\$ 38.18	29%+8.85
Groundman-Equipment Operator Class II (all other equipment).....	\$ 46.49	29%+8.85
Heavy-Equipment Operator Class I (all crawler type equipment D-4 and larger)...	\$ 52.13	29%+8.85
Lineman.....	\$ 74.55	29%+8.85

-----  
ENGI0101-001 05/01/2025

AREA 1  
ANDREW, ATCHISON, BATES, BENTON, BUCHANAN, CALDWELL, CARROLL,  
CHARITON, CLINTON, COOPER, DAVIESS, DEKALB, GENTRY, GRUNDY,  
HARRISON, HENRY, HOLT, HOWARD, JOHNSON, LAFAYETTE, LINN,  
LIVINGSTON, MERCER, NODAWAY, PETTIS, SALINE, SULLIVAN AND WORTH  
COUNITES



	Rates	Fringes
Power equipment operators:		
GROUP 1.....	\$ 38.83	21.87
GROUP 2.....	\$ 38.43	21.87
GROUP 3.....	\$ 36.43	21.87

POWER EQUIPMENT OPERATORS CLASSIFICATIONS

GROUP 1: Asphalt roller operator, finish; asphalt paver and spreader; asphalt plant operator; auto grader or trimmer or sub-grader; backhoe; blade operator (all types); boilers - 2; booster pump on dredge; bulldozer operator; boring machine (truck or crane mounted); clamshell operator; concrete mixer paver; concrete plant operator; concrete pump operator; crane operator; derrick or derrick trucks; ditching machine; dragline operator; dredge engineman; dredge operator; drill cat with compressor mounted (self-contained) or similar type self-propelled rotary drill (not air tract); drilling or boring machine (rotary-self-propelled); finishing machine operator; greaser; high loader-fork lift-skid loader (all types); hoisting engineer (2 active drums); locomotive operator (standard guage); mechanics and welders (field and plants); mucking machine operator; pile drive operator; pitman crane or boom truck (all types); push cat; quad track; scraper operators (all types); shovel operator; sideboom cats; side discharge spreader; skimmer scoop operators; slip form paver operator (CMI, Rex, Gomeco or equal); la tourneau rooter (all tiller types); tow boat operator; truck crane; wood and log chippers (all types).

GROUP 2: A-frame truck operator; articulated dump truck; back filler operator; boilers (1); chip spreader; churn drill operator; compressor; concrete mixer operator, skip loader; concrete saws (self-propelled); conveyor operator; crusher operator; distributor operator; elevating grader operator; farm tractor (all attachments); fireman rig; float operator; form grade operator; hoisting engine (one drum); maintenance operator; multiple compactor; pavement breaker, self-propelled hydra-hammer (or similar type); paymill operator; power shield; pumps; roller operator (with or without blades); screening and washing plant; self-propelled street broom or sweeper; siphons and jets; straw blower; stump cutting machine; siphons and jets; tank car heater operator (combination boiler and booster); welding machine; vibrating machine operator (not hand held); welding machine.

GROUP 3: (a) Oiler;  
           (b) Oiler driver

(c) Mechanic.

HOURLY PREMIUMS:

THE FOLLOWING CLASSIFICATIONS SHALL RECEIVE (\$ .25) ABOVE GROUP 1 RATE: Dragline operator - 3 yds. & over; shovel 3 yds. & over; clamshell 3 yds. & over; Crane, rigs or piledrivers, 100' of boom or over (incl. jib.), hoist - each additional active drum over 2 drums

THE FOLLOWING CLASSIFICATIONS SHALL RECEIVE (\$ .50) ABOVE GROUP 1 RATE: Tandem scoop operator; crane, rigs or piledrivers 150' to 200' of boom (incl. jib.)

THE FOLLOWING CLASSIFICATIONS SHALL RECEIVE (\$ .75) ABOVE GROUP 1 RATE: Crane rigs, or piledrivers 200 ft. of boom or over (including jib.)

-----  
ENGI0101-005 04/01/2025

CASS, CLAY, JACKSON, PLATTE AND RAY COUNTIES

	Rates	Fringes
Power equipment operators:		
GROUP 1.....	\$ 40.17	22.29
GROUP 2.....	\$ 39.13	22.29
GROUP 3.....	\$ 34.66	22.29
GROUP 4.....	\$ 38.01	22.29

POWER EQUIPMENT OPERATORS CLASSIFICATIONS

GROUP 1: Asphalt roller operator, finish; asphalt paver and spreader; asphalt plant operator; auto grader or trimmer or sub-grader; backhoe; blade operator (all types); boilers-2; booster pump on dredge; boring machine (truck or crane mounted); bulldozer operator; clamshell operator; concrete cleaning decontamination machine operator; concrete mixer paver; concrete plant operator; concrete pump operator; crane operator; derrick or derrick trucks; ditching machine; dragline operator; dredge engineman; dredge operator; drillcat with compressor mounted (self-contained) or similar type self propelled rotary drill (not air tract); drilling or boring machine (rotary - self-propelled); finishing machine operator; greaser; heavy equipment robotics operator/mechanic; horizontal directional drill operator; horizontal directional drill locator; loader-forklift - skid loader (all types); hoisting engineer (2 active drums); locomotive operator

(standard guage); master environmental maintenance mechanic; mechanics and welders (field and plants); mucking machine operator; piledrive operator; pitman crane or boom truck (all types); push cat; quad-track; scraper operators (all types); shovel operator; side discharge spreader; sideboom cats; skimmer scoop operator; slip-form paver (CMI, REX, Gomaco or equal); la tourneau rooter (all tiller types); tow boat operator; truck crane; ultra high perssure waterjet cutting tool system operator/mechanic; vacuum blasting machine operator/mechanic; wood and log chippers (all types)

GROUP 2: ""A"" Frame truck operator; back filler operator; boilers (1); chip spreader; churn drill operator; concrete mixer operator, skip loader; concrete saws (self-propelled); conveyor operator; crusher operator; distributor operator; elevating grader operator; farm tractor (all attachments); fireman rig; float operator; form grader operator; hoisting engine (1 drum); maintenance operator; multiple compactor; pavement breaker, self-propelled hydra- hammer (or similar type); power shield; paymill operator; pumps; siphons and jets; stump cutting machine; tank car heater operator (combination boiler and booster); compressor; roller operator (with or without blades); screening and washing plant; self-propelled street broom or sweeper; straw blower; tank car heater operator (combination boiler and booster); vibrating machine operator (not hand held)

GROUP 3: Oilers

GROUP 4: Oiler Driver (All Types)

FOOTNOTE:

HOURLY PREMIUMS FOLLOWING CLASSIFICATIONS SHALL RECEIVE (\$1.00) ABOVE GROUP 1 RATE:

Clamshells - 3 yd. capacity or over; Cranes or rigs, 80 ft. of boom or over (including jib); Draglines, 3 yd. capacity or over;

Piledrivers 80 ft. of boom or over (including jib);

Shovels & backhoes, 3 yd. capacity or over.

-----  
ENGI0101-022 05/01/2025

BARRY, BARTON, CAMDEN, CEDAR, CHRISTIAN, DADE, DALLAS, DOUGLAS, GREENE, HICKORY, JASPER, LACLEDE, LAWRENCE, MCDONALD, NEWTON, OZARK, POLK, ST. CLAIR, STONE, TANEY, VERNON, WEBSTER AND WRIGHT COUNTIES and CITY OF SPRINGFIELD

	Rates	Fringes
Power equipment operators:		
GROUP 1.....	\$ 36.60	19.32
GROUP 2.....	\$ 36.25	19.32
GROUP 3.....	\$ 36.05	19.32
GROUP 4.....	\$ 34.00	19.32

**POWER EQUIPMENT OPERATORS CLASSIFICATIONS**

GROUP 1: Asphalt finishing machine & trench widening spreader; asphalt plant console operator; autograder; automatic slipform paver; backhoe; blade operator - all types; boat operator - tow; boilers-2; central mix concrete plant operator; clamshell operator; concrete mixer paver; crane operator; derrick or derrick trucks; ditching machine; dozer operator; dragline operator; dredge booster pump; dredge engineman; dredge operator; drill cat with compressor mounted on cat; drilling or boring machine rotary self-propelled; highloader; hoisting engine - 2 active drums; launch hammer wheel; locomotive operator; - standard gauge; mechanic and welders; mucking machine; off-road trucks; piledriver operator; pitman crane operator; push cat operator; quad trac; scoop operator - all types; shovel operator; sideboom cats; skimmer scoop operators; trenching machine operator; truck crane.

GROUP 2: A-frame; asphalt hot-mix silo; asphalt plant fireman (drum or boiler); asphalt plant man; asphalt plant man; asphalt plant mixer operator; asphalt roller operator; backfiller operator; barber-greene loader; boat operator (bridges and dams); chip spreader; concrete mixer operator - skip loader; concrete plant operator; concrete pump operator; crusher operator; dredge oiler; elevating grader operator; fork lift; greaser-fleet; hoisting engine - 1; locomotive operator - narrow gauge; multiple compactor; pavement breaker; powerbroom - self-propelled; power shield; rooter; side discharge concrete spreader; slip form finishing machine; stumpcutter machine; throttle man; tractor operator (over 50 h.p.); winch truck.

GROUP 3: Boilers - 1; chip spreader (front man); churn drill operator; clef plane operator; concrete saw operator (self-propelled); curb finishing machine; distributor operator; finishing machine operator; flex plane operator; float operator; form grader operator; pugmill operator; roller operator, other than high type asphalt; screening & washing plant operator; siphons & jets; sub-grading machine operator; spreader box operator, self-propelled (not

asphalt); tank car heater operator (combination boiler & booster); tractor operator (50 h.p. or less); Ulmac, Ulric or similar spreader; vibrating machine operator, not hand;

GROUP 4: Grade checker; Oiler; Oiler-Driver

HOURLY PREMIUMS:

The following classifications shall receive \$ .25 above GROUP 1 rate:

Clamshells - 3 yds. or over; Cranes - Rigs or Piledrivers, 100 ft. of boom or over (including jib); Draglines - 3 yds. or over; Hoists - each additional active drum over 2 drums; Shovels - 3 yds. or over;

The following classifications shall receive \$ .50 above GROUP 1 rate:

Tandem scoop operator; Cranes - Rigs or Piledrivers, 150 ft. to 200 ft. of boom (including jib); Tandem scoop.

The following classifications shall receive \$ .75 above GROUP 1 rate:

Cranes - Rigs or Piledrivers, 200 ft. of boom or over (including jib.).

-----  
 ENGI0513-004 05/05/2025

FRANKLIN, JEFFERSON, LINCOLN, ST CHARLES, AND WARREN COUNTIES

	Rates	Fringes
Power equipment operators:		
GROUP 1.....	\$ 45.96	30.96
GROUP 2.....	\$ 45.96	30.96
GROUP 3.....	\$ 44.66	30.96
GROUP 4.....	\$ 44.22	30.96

POWER EQUIPMENT OPERATORS CLASSIFICATIONS

GROUP 1: Backhoe, Cable; Backhoe, Hydraulic (2 cu yds bucket and under regardless of attachment, one oiler for 2 or 3, two oilers for 4 through 6); Backhoe, Hydraulic over 2 cu yds; Cableway; Crane, Crawler or Truck; Crane, Hydraulic - Truck or Cruiser mounted, 16 tons and over; Crane, Locomotive; crane with boom including jib over 100 ft from pin to pin; Crane using rock socket tool; Derrick, Steam; Derrick Car and Derrick Boat; Dragline, 7 cu yds and over; Dredge; Gradall, Crawler or tire mounted; Locomotive, Gas, Steam & other powers; Pile Driver, Land or Floating; Scoop,

Skimmer; Shovel, Power (Electric, Gas, Steam or other powers); Shovel, Power (7 cu yds and over); Switch Boat; Whirley; Air Tugger with air compressor; Anchor Placing Barge; Asphalt Spreader; Athey Force Feeder Loader, self-propelled; Backfilling Machine; Boat Operator - Push Boat or Tow Boat (job site); Boiler, High Pressure Breaking in Period; Boom Truck, Placing or Erecting; Boring Machine, Footing Foundation; Bullfloat; Cherry Picker; Combination Concrete Hoist and Mixer (such as Mixermobile); Compressor, Two 125 CFM and under; Compressor, Two through Four over 125 CFM; Compressor when operator runs throttle; Concrete Breaker (Truck or Tractor mounted); Concrete Pump (such as Pumpcrete machine); Concrete Saw (self-propelled); Concrete Spreader; Conveyor, Large (not selfpropelled) hoisting or moving brick and concrete into, or into and on floor level, one or both; Crane, Cimbing (such as Linden); Crane, Hydraulic - Rough Terrain, self-propelled; Crane, Hydraulic - Truck or Cruiser mounted - under 16 tons; Drilling machine - Self-powered, used for earth or rock drilling or boring (wagon drills and any hand drills obtaining power from other souces including concrete breakers, jackhammers and Barco equipmnet no engineer required); Elevating Grader; Engine Man, Dredge; Excavator or Powerbelt Machine; Finishing Machine, self- propelled oscillating screed; Forklift; Generators, Two through Six 30 KW or over; Grader, Road with power blade; Greaser; Highlift; Hoist, Concrete and Brick (Brick cages or concrete skips operating or on tower, Towermobile, or similar equipment); Hoist, Three or more drums in use; Hoist, Stack; Hydro-Hammer; Lad-A-Vator, hoisting brick or concrete; Loading Machine such as Barber-Greene; Mechanic on job site

GROUP 2: Air Tugger with plant air; Boiler (for power or heating shell of building or temporary enclosures in connection with construction work); Boiler, Temporary; Compressor, One over 125 CFM; Compressor, truck mounted; Conveyor, Large (not self- propelled); Conveyor, Large (not self- propelled) moving brick and concrete (distributing) on floor level; Curb Finishing Machine; Ditch Paving Machine; Elevator (outside); Endless Chain Hoist; Fireman (as required); Form Grader; Hoist, One Drum regardless of size (except brick or concrete); Lad-A-Vator, other hoisting; Manlift; Mixer, Asphalt, over 8 cu ft capacity; Mixer, one bag capacity or less; Mixer, without side loader, two bag capacity or more; Mixer, with side loader, regardless of size, not Paver; Mud Jack (where mud jack is used in conjenction with an air compressor, operator shall be paid \$ .55 per hour in addition to his basic hourly rate for covering both operations); Pug Mill operator; Pump, Sump - self powered, automatic controlled over 2""; Scissor

Lift (used for hoisting); Skid Steer Loader; Sweeper, Street; Tractor, small wheel type 50 HP and under with grader blade and similar equipment; Welding Machine, One over 400 amp; Winch, operating from truck

GROUP 3: Boat operator - outboard motor, job site; Conveyors (such as Con-Vay-It) regardless of how used; Elevator (inside); Heater operator, 2 through 6; Sweeper, Floor

GROUP 4: Crane type

HOURLY PREMIUMS:

Backhoe, Hydraulic 2 cu yds or less without oiler - \$2.00;  
 Crane, climbing (such as Linden) - \$.50;  
 Crane, Pile Driving and Extracting - \$ .50  
 Crane with boom (including job) over 100 ft from pin to pin - add \$.01 per foot to maximum of \$4.00);  
 Crane, using rock socket tool - \$ .50;  
 Derrick, diesel, gas or electric hoisting material and erecting steel (150 ft or more above ground) - \$ .50;  
 Dragline, 7 cu yds and over - \$ .50;  
 Hoist, Three or more drums in use - \$ .50;  
 Scoop, Tandem - \$.50;  
 Shovel, Power - 7 cu yds and over - \$ .50;  
 Tractor, Tandem Crawler - \$ .50;  
 Tunnel, man assigned to work in tunnel or tunnel shaft - \$ .50;  
 Wrecking, when machines are working on second floor or higher - \$ .50

-----  
 ENGI0513-006 05/01/2025

ADAIR, AUDRAIN, BOLLINGER, BOONE, BUTLER, CALLAWAY, CAPE GIRARDEAU, CARTER, CLARK, COLE, CRAWFORD, DENT, DUNKLIN, GASCONADE, HOWELL, IRON, KNOX, LEWIS, MACON, MADISON, MARIES, MARION, MILLER, MISSISSIPPI, MONITEAU, MONROE, MONTGOMERY, MORGAN, NEW MADRID, OREGON, OSAGE, PEMISCOT, PERRY, PHELPS, PIKE, PULASKI, PUTNAM, RALLS, RANDOLPH, REYNOLDS, RIPLEY, ST. FRANCOIS, STE. GENEVIEVE, SCHUYLER, SCOTLAND, SCOTT, SHANNON, SHELBY, STODDARD, TEXAS, WASHINGTON, AND WAYNE COUNTIES

	Rates	Fringes
Power equipment operators:		
GROUP 1.....	\$ 40.39	30.33
GROUP 2.....	\$ 40.04	30.33

GROUP 3.....	\$ 39.84	30.33
GROUP 4.....	\$ 36.19	30.33

POWER EQUIPMENT OPERATORS CLASSIFICATIONS

GROUP 1: Asphalt finishing machine & trench widening spreader, asphalt plant console operator; autograder; automatic slipform paver; back hoe; blade operator - all types; boat operator tow; boiler two; central mix concrete plant operator; clam shell operator; concrete mixer paver; crane operator; derrick or derrick trucks; ditching machine; dozer operator; dragline operator; dredge booster pump; dredge engineman; dredge operator; drill cat with compressor mounted on cat; drilling or boring machine rotary self-propelled; highloader; hoisting engine 2 active drums; launchhammer wheel; locomotive operator standrad guage; mechanics and welders; mucking machine; piledriver operator; pitman crane operator; push cat operator; quad-trac; scoop operator; sideboom cats; skimmer scoop operator; trenching machine operator; truck crane, shovel operator.

GROUP 2: A-Frame; asphalt hot-mix silo; asphalt roller operator asphalt plant fireman (drum or boiler); asphalt plant man; asphalt plant mixer operator; backfiller operator; barber-greene loader; boat operator (bridge & dams); chip spreader; concrete mixer operator skip loader; concrete plant operator; concrete pump operator; dredge oiler; elevating graded operator; fork lift; grease fleet; hoisting engine one; locomotive operator narrow guage; multiple compactor; pavement breaker; powerbroom self-propelled; power shield; rooter; slip-form finishing machine; stumpcutter machine; side discharge concrete spreader; throttleman; tractor operator (over 50 hp); winch truck; asphalt roller operator; crusher operator.

GROUP 3: Spreader box operator, self-propelled not asphalt; tractor operator (50 h.p. or less); boilers one; chip spreader (front man); churn drill operator; compressor over 105 CFM 2-3 pumps 4" & over; 2-3 light plant 7.5 KWA or any combination thereof; clef plane operator; compressor maintenance operator 2 or 3; concrete saw operator (self-propelled); curb finishing mancine; distributor operator; finishing machine operator; flex plane operator; float operator; form grader operator; pugmill operator; riller operator other than high type asphalt; screening & washing plant operator; siphons & jets; subgrading machine operator; tank car heater (combination boiler & booster); ulmac, ulric or similar spreader; vibrating machine operator; hydrobroom.



GROUP 4: Oiler; grout machine; oiler driver; compressor over 105 CFM one; conveyor operator one; maintenance operator; pump 4" & over one.

FOOTNOTE: HOURLY PREMIUMS

- Backhoe hydraulic, 2 cu. yds. or under Without oiler - \$2.00
- Certified Crane Operator - \$1.50;
- Certified Hazardous Material Operator \$1.50;
- Crane, climbing (such as Linden) - \$0.50;
- Crane, pile driving and extracting - \$0.50;
- Crane, with boom (including jib) over 100' from pin to pin add \$0.01 per foot to maximum of \$4.00;
- Crane, using rock socket tool - \$0.50;
- Derrick, diesel, gas or electric, hoisting material and erecting steel (150' or more above the ground) - \$0.50;
- Dragline, 7 cu. yds, and over - \$0.50;
- Hoist, three or more drums in use - \$0.50; Scoop, Tandem - \$0.50;
- Shovel, power - 7 cu. yds. or more - \$0.50;
- Tractor, tandem crawler - \$0.50;
- Tunnel, man assigned to work in tunnel or tunnel shaft - \$0.50;
- Wrecking, when machine is working on second floor or higher - \$0.50;

-----  
 ENGI0513-007 05/05/2025

ST. LOUIS CITY AND COUNTY

	Rates	Fringes
Power equipment operators:		
GROUP 1.....	\$ 45.96	30.96
GROUP 2.....	\$ 45.96	30.96
GROUP 3.....	\$ 44.66	30.96
GROUP 4.....	\$ 44.22	30.96

POWER EQUIPMENT OPERATORS CLASSIFICATIONS

GROUP 1: Backhoe, cable or hydraulic; cableway; crane crawler or truck; crane, hydraulic-truck or cruiser mounted 16 tons & over; crane locomotive; derrick, steam; derrick car & derrick boat; dragline; dredge; gradall, crawler or tire mounted; locomotive, gas, steam & other powers; pile driver, land or floating; scoop, skimmer; shovel, power (steam, gas, electric or other powers); switch boat; whirley.

GROUP 2: Air tugger w/air compressor; anchor-placing barge; asphalt spreader; atehy force feeder loader (self-propelled); backfilling machine; backhoe-loader; boat operator-push boat or tow boat (job site); boiler, high pressure breaking in period; boom truck, placing or erecting; boring machine, footing foundation; bull- float; cherry picker; combination concrete hoist & mixer (such as mixer mobile); compressor (when operator runs throttle); concrete breaker (truck or tractor mounted); concrete pump, such as pump-crete machine; concrete saw (self-propelled), concrete spreader; conveyor, large (not self-propelled), hoisting or moving brick and concrete into, or into and on floor level, one or both; crane, hydraulic-rough terrain, self-propelled; crane hydraulic-truck or cruiser mounted-under 16 tons; drilling machines, self-powered use for earth or rock drilling or boring (wagon drills nd any hand drills obtaining power from other sources including concrete breakers, jackhammers and barco equipment-no engineer required); elevating grader; engineman, dredge; excavator or powerbelt machine; finishing machine, self-propelled oscillating screed; forklift; grader, road with power blade; highlift. greaser; hoist, stack, hydro-hammer; loading machine (such as barber-greene); machanic, on job site; mixer, pipe wrapping machines; plant asphalt; plant, concrete producing or ready-mix job site; plant heating-job site; plant mixing-job site; plant power, generating-job site; pumps, two through six self-powered over 2"; pumps, electric submersible, two through six, over 4"; quad-track; roller, asphalt, top or sub-grade; scoop, tractor drawn; spreader box; sub-grader; tie tamper; tractor-crawler, or wheel type with or without power unit, power take-offs and attachments regardless of size; trenching machine; tunnel boring machine; vibrating machine automatic, automatic propelled; welding machines (gasoline or diesel) two through six; well drilling machine

GROUP 3: Conveyor, large (not self-propelled); conveyor, large (not self-propelled) moving brick and concrete distributing) on floor level; mixer two or more mixers of one bag capacity or less; air tugger w/plant air; boiler, for power or heating on construction projects; boiler, temporary; compressor (mounted on truck; curb finishing machine; ditch paving machine; elevator; endless chain hoist; form grader; hoist, one drum regardless of size; lad-a-vator; manlift; mixer, asphalt, over 8 cu. ft. capacity, without side loader, 2 bag capacity or more; mixer, with side loader, regardless of size; pug mill operator; pump, sump-self-powered, automatic controlled over 2" during use in connection with construction work;

sweeper, street; welding machine, one over 400 amp.; winch operating from truck; scissor lift (used for hoisting); tractor, small wheel type 50 h.p. & under with grader blade & similar equipment; Oiler on dredge and on truck crane.

GROUP 4: Boat operator-outboard motor (job site); conveyor (such as con-vay-it) regardless of how used; sweeper, floor

HOURLY PREMIUMS:

Backhoe, hydraulic	
2 cu. yds. or under without oiler	\$2.00
Certified Crane Operator	1.50
Certified Hazardous Material Operator	1.50
Crane, climbing (such as Linden)	.50
Crane, pile driving and extracting	.50
Crane, with boom (including jib) over 100' (from pin to pin) add \$.01 per foot to maximum of	4.00
Crane, using rock socket tool	.50
Derrick, diesel, gas or electric, hoisting material and erecting steel (150' or more above ground)	.50
Dragline, 7 cu. yds. and over	.50
Hoist, three (3) or more drums in use	.50
Scoop, Tandem	.50
Shovel, power - 7 cu. yds. or more	.50
Tractor, tandem crawler	.50
Tunnel, man assigned to work in tunnel or tunnel shaft	.50
Wrecking, when machine is working on second floor or higher	.50

-----  
IRON0010-012 04/01/2025

Rates                      Fringes

Ironworkers:

ANDREW, BARTON, BENTON,  
CAMDEN, CEDAR, CHARITON,  
CHRISTIAN, COOPER, DADE,  
DALLAS, DAVIESS, DE KALB,  
GENTRY, GREENE, GRUNDY,  
HARRISON, HICKORY, HOLT,  
HOWARD, LACLEDE, LINN,  
LIVINGSTON, MERCER,  
MONITEAU, MORGAN, NODAWAY,  
PETTIS, POLK, PUTNAM,  
RANDLOPH, ST. CLAIR,  
SULLIVAN, TANEY, VERNON,

WEBSTER, WRIGHT and WORTH  
 Counties and portions of  
 ADAIR, BOONE, MACON,  
 MILLER and RANDOLPH  
 Counties.....\$ 36.00                    34.25  
 ATCHISON, BATES, BUCHANAN,  
 CALDWELL, CARROLL, CASS,  
 CLAY, CLINTON, HENRY,  
 JACKSON, JOHNSON,  
 LAFAYETTE, PETTIS, PLATTE,  
 SALINE, AND RAY COUNTIES....\$ 39.00                    34.25

-----  
 IRON0010-020 04/01/2025

BARRY, JASPER, LAWRENCE, MCDONALD, NEWTON AND STONE Counties

	Rates	Fringes
Ironworkers:.....	\$ 36.00	34.25

-----  
 IRON0321-002 08/01/2023

DOUGLAS, HOWELL and OZARK COUNTIES

	Rates	Fringes
Ironworker.....	\$ 27.00	20.96

-----  
 IRON0396-004 08/07/2024

ST. LOUIS (City and County), ST. CHARLES, JEFFERSON, IRON,  
 FRANKLIN, LINCOLN, WARREN, WASHINGTON, ST. FRANCOIS, STE.  
 GENEVIEVE, and REYNOLDS Counties; and portions of MADISON,  
 PERRY, BOLLINGER, WAYNE, and CARTER Counties

	Rates	Fringes
Ironworker.....	\$ 41.67	31.25

-----  
 IRON0396-009 08/07/2024

AUDRAIN, CALLAWAY, COLE, CRAWFORD, DENT, GASCONADE, MARIES,  
 MONTGOMERY, OSAGE, PHELPS, PIKE, PULASKI, TEXAS and WRIGHT  
 Counties; and portions of BOONE, CAMDEN, DOUGLAS, HOWELL,  
 LACLEDE, MILLER, MONROE, OREGON, SHANNON and RALLS Counties

	Rates	Fringes
--	-------	---------

Ironworker.....\$ 41.67 31.25

-----  
IRON0577-005 06/01/2024

ADAIR, CLARK, KNOX, LEWIS, MACON, MARION, MONROE, RALLS,  
SCHUYLER, SCOTLAND, AND SHELBY COUNTIES

Rates Fringes

Ironworker.....\$ 34.05 25.30

-----  
IRON0782-003 08/01/2023

CAPE GIRARDEAU, MISSISSIPPI, NEW MADRID, SCOTT, & STODDARD  
Counties; and portions of BOLLINGER, BUTLER, CARTER, DUNKLIN,  
MADISON, PEMISCOT, PERRY, RIPLEY, and WAYNE Counties

Rates Fringes

Ironworkers:

Locks, Dams, Bridges and  
other major work on the  
Mississippi and Ohio River

only.....\$ 38.77 29.51

All Other Work.....\$ 33.47 24.12

-----  
LAB00042-003 06/04/2025

ST. LOUIS (City and County)

Rates Fringes

LABORER

Plumber Laborer.....\$ 40.82 17.56

-----  
LAB00042-005 06/04/2025

ST. LOUIS (City and County)

Rates Fringes

LABORER

Dynamiter, Powderman.....\$ 40.82 17.56

Laborers, Flaggers.....\$ 40.82 17.56

Wrecking.....\$ 40.82 17.56

-----  
LAB00110-005 05/01/2024

Jefferson and Washington Counties

	Rates	Fringes
LABORER (Jefferson County)		
GROUP 1.....	\$ 38.24	15.55
GROUP 2.....	\$ 38.24	15.55
LABORER (Washington County)		
GROUP 1.....	\$ 35.13	15.55
GROUP 2.....	\$ 35.12	15.55

LABORERS CLASSIFICATIONS

GROUP 1 - General laborer-flagman, carpenter tenders; salamander Tenders; Dump Man; Ticket Takers; loading trucks under bins, hoppers, and conveyors; track man; cement handler; dump man on earth fill; georgie buggy man; material batch hopper man; spreader on asphalt machine; material mixer man (except on manholes); coffer dams; riprap pavers rock, block or brick; scaffolds over ten feet not self-supported from ground up; skip man on concrete paving; wire mesh setters on concrete paving; all work in connection with sewer, water, gas, gasoling, oil, drainage pipe, conduit pipe, tile and duct lines and all other pipe lines; power tool operator; all work in connection with hydraulic or general dredging operations; form setters, puddlers (paving only); straw blower nozzle man; asphalt plant platform man; chuck tender; crusher feeder; men handling creosote ties or creosote materials; men working with and handling epoxy material; topper of standing trees; feeder man on wood pulverizers, board and willow mat weavers and cabelee tiers on river work; deck hands; pile dike and revetment work; all laborers working on underground tunnels less than 25 ft. where compressed air is not used; abutement and pier hole men working six (6) ft. or more below ground; men working in coffer dams for bridge piers and footing in the river; barco tamper; jackson or any other similar tamp; cutting torch man; liners, curb, gutters, ditch lines; hot mastic kettlemen; hot tar applicator; hand blade operator; mortar men or brick or block manholes; rubbing concrete, air tool operator under 65 lbs.; caulker and lead man; chain or concrete saw under 15 h.p.; signal Gan; Guard rail and sign erectors.

GROUP 2 - Skilled laborers - Vibrator man; asphalt raker; head pipe layer on sewer work; batterboard man on pipe and ditch work; cliff scalers working from bosun's chairs; scaffolds or platforms on dams or power plants over 10 ft. high; air tool operator over 65 lbs.; stringline man on

concrete paving; sandblast man; laser beam man; wagon drill; churn drill; air track drill and all other similar type drills, gunite nozzle man; pressure grout man; screed man on asphalt; concrete saw 15 h.p. and over; grade checker; strigline man on electronic grade control; manhole builder; dynamite man; powder man; welder; tunnel man; waterblaster - 1000 psi or over; asbestos and/or hazardous waste removal and/or disposal

-----  
 LAB00579-005 05/01/2023

	Rates	Fringes
LABORER (ANDREW, ATCHISON, BUCHANAN, CALDWELL, CLINTON, DAVIESS, DEKALB, GENTRY, GRUNDY, HARRISON, HOLT, LIVINGSTON, MERCER, NODAWAY and WORTH COUNTIES.)		
GROUP 1.....	\$ 29.04	16.59
GROUP 2.....	\$ 29.39	16.59
LABORER (BARRY, BARTON, BATES, BENTON, CAMDEN, CARROLL, CEDAR, CHRISTIAN, DADE, DALLAS, DOUGLAS, GREENE, HENRY. HICKORY, JASPER, JOHNSON, LACLEDE, LAWRENCE, MCDONALD, MORGAN, NEWTON, OZARK, PETTIS, POLK, ST.CLAIR, SALINE, STONE, TANEY, VERNON, WEBSTER and WRIGHT COUNTIES)		
GROUP 1.....	\$ 28.23	15.60
GROUP 2.....	\$ 28.78	15.60
LABORER (LAFAYETTE COUNTY)		
GROUP 1.....	\$ 29.78	15.85
GROUP 2.....	\$ 30.13	15.85

LABORERS CLASSIFICATIONS

GROUP 1: General Laborers - Carpenter tenders; salamander tenders; loading trucks under bins; hoppers & conveyors; track men & all other general laborers; air tool operator; cement handler-bulk or sack; dump man on earth fill; georgie buggy man; material batch hopper man; material mixer man (except on manholes); coffer dams; riprap pavers - rock, block or brick; signal man; scaffolds over ten feet not self-supported from ground up; skipman on concrete paving; wire mesh setters on concrete paving; all work in

connection with sewer, water, gas, gasoline, oil drainage pipe, conduit pipe, tile and duct lines and all other pipe lines; power tool operator, all work in connection with hydraulic or general dredging operations; puddlers (paving only); straw blower nozzle man; asphalt plant platform man; chuck tender; crusher feeder; men handling creosote ties or creosote materials; men working with and handling epoxy material or materials (where special protection is required); rubbing concrete; topper of standing trees; batter board man on pipe and ditch work; feeder man on wood pulverizers; board and willow mat weavers and cable tiers on river work; deck hands; pile dike and revetment work; all laborers working on underground tunnels less than 25 feet where compressed air is not used; abutment and pier hole men working six (6) feet or more below ground; men working in coffer dams for bridge piers and footings in the river; ditchliners; pressure groutmen; caulker; chain or concrete saw; cliffscalers working from scaffolds, bosuns' chairs or platforms on dams or power plants over (10) feet above ground; mortarmen on brick or block manholes; toxic and hazardous waste work.

GROUP 2: Skilled Laborers - Head pipe layer on sewer work; laser beam man; Jackson or any other similar tamp; cutting torch man; form setters; liners and stringline men on concrete paving, curb, gutters; hot mastic kettleman; hot tar applicator; sandblasting and gunite nozzle men; air tool operator in tunnels; screed man on asphalt machine; asphalt raker; barco tamper; churn drills; air track drills and all similar drills; vibrator man; stringline man for electronic grade control; manhole builders-brick or block; dynamite and powder men; grade checker.

-----  
 LAB00660-004 05/01/2024

Clark, Knox, Lewis, Marion, Pike, Ralls, Scotland, Shelby Counties

	Rates	Fringes
LABORER		
GROUP 1.....	\$ 35.13	15.55
GROUP 2.....	\$ 35.13	15.55

LABORERS CLASSIFICATIONS

GROUP 1 - General laborer-flagman, carpenter tenders; salamander Tenders; Dump Man; Ticket Takers; loading trucks



under bins, hoppers, and conveyors; track man; cement handler; dump man on earth fill; georgie buggy man; material batch hopper man; spreader on asphalt machine; material mixer man (except on manholes); coffer dams; riprap pavers rock, block or brick; scaffolds over ten feet not self-supported from ground up; skip man on concrete paving; wire mesh setters on concrete paving; all work in connection with sewer, water, gas, gasoling, oil, drainage pipe, conduit pipe, tile and duct lines and all other pipe lines; power tool operator; all work in connection with hydraulic or general dredging operations; form setters, puddlers (paving only); straw blower nozzle man; asphalt plant platform man; chuck tender; crusher feeder; men handling creosote ties or creosote materials; men working with and handling epoxy material; topper of standing trees; feeder man on wood pulverizers, board and willow mat weavers and cabelee tiers on river work; deck hands; pile dike and revetment work; all laborers working on underground tunnels less than 25 ft. where compressed air is not used; abutement and pier hole men working six (6) ft. or more below ground; men working in coffer dams for bridge piers and footing in the river; barco tamper; jackson or any other similar tamp; cutting torch man; liners, curb, gutters, ditch lines; hot mastic kettlemen; hot tar applicator; hand blade operator; mortar men or brick or block manholes; rubbing concrete, air tool operator under 65 lbs.; caulker and lead man; chain or concrete saw under 15 h.p.; signal Gan; Guard rail and sign erectors.

GROUP 2 - Skilled laborers - Vibrator man; asphalt raker; head pipe layer on sewer work; batterboard man on pipe and ditch work; cliff scalers working from bosun's chairs; scaffolds or platforms on dams or power plants over 10 ft. high; air tool operator over 65 lbs.; stringline man on concrete paving; sandblast man; laser beam man; wagon drill; churn drill; air track drill and all other similar type drills, gunite nozzle man; pressure grout man; screed man on asphalt; concrete saw 15 h.p. and over; grade checker; strigline man on electronic grade control; manhole builder; dynamite man; powder man; welder; tunnel man; waterblaster - 1000 psi or over; asbestos and/or hazardous waste removal and/or disposal

---

LAB00660-006 06/02/2025

Lincoln, Montgomery, St Charles and Warren Counties

Rates

Fringes

LABORER (Common or General).....\$ 36.91	15.62
Lincoln, Monntomery, and Warrner Counties.....\$ 39.76	15.96
St. Charles County.....\$ 41.18	15.96

-----  
LAB00662-001 05/01/2024

Callaway, Cole, Miller and Moniteau Counties

	Rates	Fringes
LABORER		
GROUP 1.....\$ 38.24	38.24	15.55
GROUP 2.....\$ 38.24	38.24	15.55

LABORERS CLASSIFICATIONS

GROUP 1 - General laborer-flagman, carpenter tenders; salamander Tenders; Dump Man; Ticket Takers; loading trucks under bins, hoppers, and conveyors; track man; cement handler; dump man on earth fill; georgie buggy man; material batch hopper man; spreader on asphalt machine; material mixer man (except on manholes); coffer dams; riprap pavers rock, block or brick; scaffolds over ten feet not self-supported from ground up; skip man on concrete paving; wire mesh setters on concrete paving; all work in connection with sewer, water, gas, gasoling, oil, drainage pipe, conduit pipe, tile and duct lines and all other pipe lines; power tool operator; all work in connection with hydraulic or general dredging operations; form setters, puddlers (paving only); straw blower nozzle man; asphalt plant platform man; chuck tender; crusher feeder; men handling creosote ties or creosote materials; men working with and handling epoxy material; topper of standing trees; feeder man on wood pulverizers, board and willow mat weavers and cabelee tiers on river work; deck hands; pile dike and revetment work; all laborers working on underground tunnels less than 25 ft. where compressed air is not used; abutement and pier hole men working six (6) ft. or more below ground; men working in coffer dams for bridge piers and footing in the river; barco tamper; jackson or any other similar tamp; cutting torch man; liners, curb, gutters, ditch lines; hot mastic kettlemen; hot tar applicator; hand blade operator; mortar men or brick or block manholes; rubbing concrete, air tool operator under 65 lbs.; caulker and lead man; chain or concrete saw under 15 h.p.; signal Gan; Guard rail and sign erectors.

GROUP 2 - Skilled laborers - Vibrator man; asphalt raker; head pipe layer on sewer work; batterboard man on pipe and ditch work; cliff scalers working from bosun's chairs; scaffolds or platforms on dams or power plants over 10 ft. high; air tool operator over 65 lbs.; stringline man on concrete paving; sandblast man; laser beam man; wagon drill; churn drill; air track drill and all other similar type drills, gunite nozzle man; pressure grout man; screed man on asphalt; concrete saw 15 h.p. and over; grade checker; strigline man on electronic grade control; manhole builder; dynamite man; powder man; welder; tunnel man; waterblaster - 1000 psi or over; asbestos and/or hazardous waste removal and/or disposal

-----  
 LAB00663-002 04/01/2025

CASS, CLAY, JACKSON, PLATTE AND RAY COUNTIES

	Rates	Fringes
LABORER		
GROUP 1.....	\$ 36.24	15.87
GROUP 2.....	\$ 37.45	15.87

LABORERS CLASSIFICATIONS

GROUP 1: General laborers, Carpenter tenders, salamander tenders, loading trucks under bins, hoppers and conveyors, track men and all other general laborers, air tool operator, cement handler (bulk or sack), chain or concrete saw, deck hands, dump man on earth fill, Georgie Buggies man, material batch hopper man, scale man, material mixer man (except on manholes), coffer dams, abutments and pier hole men working below ground, riprap pavers rock, black or brick, signal man, scaffolds over ten feet not self-supported from ground up, skipman on concrete paving, wire mesh setters on concrete paving, all work in connection with sewer, water, gas, gasoling, oil, drainage pipe, conduit pipe, tile and duct lines and all other pipelines, power tool operator, all work in connection with hydraulic or general dredging operations, straw blower nozzle man, asphalt plant platform man, chuck tender, crusher feeder, men handling creosote ties on creosote materials, men working with and handling epoxy material or materials (where special protection is required), topper of standing trees, batter board man on pipe and ditch work, feeder man on wood pulverizers, board and willow mat weavers and cable tiers on river work, deck hands, pile dike and revetment work, all laborers working on underground tunnels less than

25 feet where compressed air is not used, abutment and pier hole men working six (6) feet or more below ground, men working in coffer dams for bridge piers and footings in the river, ditchliners, pressure groutmen, caulker and chain or concrete saw, cliffscalers working from scaffolds, bosuns' chairs or platforms on dams or power plants over (10) feet above ground, mortarmen on brick or block manholes, signal man.

GROUP 2: Skilled Laborer - spreader or screed man on asphalt machine, asphalt raker, grade checker, vibrator man, concrete saw over 5 hp., laser beam man, barco tamper, jackson or any other similar tamp, wagon driller, churn drills, air track drills and other similar drills, cutting torch man, form setters, liners and stringline men on concrete paving, curb, gutters and etc., hot mastic kettleman, hot tar applicator, hand blade operators, mortar men on brick or block manholes, sand blasting and gunnite nozzle men, rubbing concrete, air tool operator in tunnels, head pipe layer on sewer work, manhole builder (brick or block), dynamite and powder men.

-----  
 LAB00840-011 05/01/2024

Crawford, Dent, Franklin, Gasconade, Howell, Maries, Oregon, Osage, Phelps, Pulaski, Shannon and Texas Counties

	Rates	Fringes
LABORER (Crawford, Dent, Gasconade, Howell, Maries, Oregon, Osage, Phelps, Pulaski, Shannon and Texas Counties)		
GROUP 1.....	\$ 35.13	15.55
GROUP 2.....	\$ 35.13	15.55
LABORER (Franklin County)		
GROUP 1.....	\$ 38.19	15.55
GROUP 2.....	\$ 38.19	15.55

LABORERS CLASSIFICATIONS

GROUP 1 - General laborer-flagman, carpenter tenders; salamander Tenders; Dump Man; Ticket Takers; loading trucks under bins, hoppers, and conveyors; track man; cement handler; dump man on earth fill; georgie buggy man; material batch hopper man; spreader on asphalt machine; material mixer man (except on manholes); coffer dams;

riprap pavers rock, block or brick; scaffolds over ten feet not self-supported from ground up; skip man on concrete paving; wire mesh setters on concrete paving; all work in connection with sewer, water, gas, gasoling, oil, drainage pipe, conduit pipe, tile and duct lines and all other pipe lines; power tool operator; all work in connection with hydraulic or general dredging operations; form setters, puddlers (paving only); straw blower nozzle man; asphalt plant platform man; chuck tender; crusher feeder; men handling creosote ties or creosote materials; men working with and handling epoxy material; topper of standing trees; feeder man on wood pulverizers, board and willow mat weavers and cabelee tiers on river work; deck hands; pile dike and revetment work; all laborers working on underground tunnels less than 25 ft. where compressed air is not used; abutment and pier hole men working six (6) ft. or more below ground; men working in coffer dams for bridge piers and footing in the river; barco tamper; jackson or any other similar tamp; cutting torch man; liners, curb, gutters, ditch lines; hot mastic kettlemen; hot tar applicator; hand blade operator; mortar men or brick or block manholes; rubbing concrete, air tool operator under 65 lbs.; caulker and lead man; chain or concrete saw under 15 h.p.; signal Gan; Guard rail and sign erectors.

GROUP 2 - Skilled laborers - Vibrator man; asphalt raker; head pipe layer on sewer work; batterboard man on pipe and ditch work; cliff scalers working from bosun's chairs; scaffolds or platforms on dams or power plants over 10 ft. high; air tool operator over 65 lbs.; stringline man on concrete paving; sandblast man; laser beam man; wagon drill; churn drill; air track drill and all other similar type drills, gunite nozzle man; pressure grout man; screed man on asphalt; concrete saw 15 h.p. and over; grade checker; strigline man on electronic grade control; manhole builder; dynamite man; powder man; welder; tunnel man; waterblaster - 1000 psi or over; asbestos and/or hazardous waste removal and/or disposal

-----  
LAB00955-012 05/01/2024

Adair, Audrain, Boone, Chariton, Cooper, Howard, Linn, Macon, Monroe, Putnam, Randolph, Schuyler and Sullivan Counties

Rates Fringes

LABORER

GROUP 1.....	\$ 35.13	15.55
GROUP 2.....	\$ 35.13	15.55

LABORERS CLASSIFICATIONS

GROUP 1 - General laborer-flagman, carpenter tenders; salamander Tenders; Dump Man; Ticket Takers; loading trucks under bins, hoppers, and conveyors; track man; cement handler; dump man on earth fill; georgie buggy man; material batch hopper man; spreader on asphalt machine; material mixer man (except on manholes); coffer dams; riprap pavers rock, block or brick; scaffolds over ten feet not self-supported from ground up; skip man on concrete paving; wire mesh setters on concrete paving; all work in connection with sewer, water, gas, gasoling, oil, drainage pipe, conduit pipe, tile and duct lines and all other pipe lines; power tool operator; all work in connection with hydraulic or general dredging operations; form setters, puddlers (paving only); straw blower nozzle man; asphalt plant platform man; chuck tender; crusher feeder; men handling creosote ties or creosote materials; men working with and handling epoxy material; topper of standing trees; feeder man on wood pulverizers, board and willow mat weavers and cabelee tiers on river work; deck hands; pile dike and revetment work; all laborers working on underground tunnels less than 25 ft. where compressed air is not used; abutment and pier hole men working six (6) ft. or more below ground; men working in coffer dams for bridge piers and footing in the river; barco tamper; jackson or any other similar tamp; cutting torch man; liners, curb, gutters, ditch lines; hot mastic kettlemen; hot tar applicator; hand blade operator; mortar men or brick or block manholes; rubbing concrete, air tool operator under 65 lbs.; caulker and lead man; chain or concrete saw under 15 h.p.; signal Gan; Guard rail and sign erectors.

GROUP 2 - Skilled laborers - Vibrator man; asphalt raker; head pipe layer on sewer work; batterboard man on pipe and ditch work; cliff scalers working from bosun's chairs; scaffolds or platforms on dams or power plants over 10 ft. high; air tool operator over 65 lbs.; stringline man on concrete paving; sandblast man; laser beam man; wagon drill; churn drill; air track drill and all other similar type drills, gunite nozzle man; pressure grout man; screed man on asphalt; concrete saw 15 h.p. and over; grade checker; strigline man on electronic grade control; manhole builder; dynamite man; powder man; welder; tunnel man; waterblaster - 1000 psi or over; asbestos and/or hazardous waste removal and/or disposal

LAB01104-005 05/01/2024

Bollinger, Butler, Cape Girardeau, Carter, Dunklin, Iron, Madison, Mississippi, New Madrid, Pemiscot, Perry, Reynolds, Ripley, Scott, St Francois, Ste Genevieve, Stoddard and Wayne Counties

	Rates	Fringes
LABORER		
GROUP 1.....	\$ 35.13	15.55
GROUP 2.....	\$ 35.13	15.55

LABORERS CLASSIFICATIONS

GROUP 1 - General laborer-flagman, carpenter tenders; salamander Tenders; Dump Man; Ticket Takers; loading trucks under bins, hoppers, and conveyors; track man; cement handler; dump man on earth fill; georgie buggy man; material batch hopper man; spreader on asphalt machine; material mixer man (except on manholes); coffer dams; riprap pavers rock, block or brick; scaffolds over ten feet not self-supported from ground up; skip man on concrete paving; wire mesh setters on concrete paving; all work in connection with sewer, water, gas, gasoling, oil, drainage pipe, conduit pipe, tile and duct lines and all other pipe lines; power tool operator; all work in connection with hydraulic or general dredging operations; form setters, puddlers (paving only); straw blower nozzle man; asphalt plant platform man; chuck tender; crusher feeder; men handling creosote ties or creosote materials; men working with and handling epoxy material; topper of standing trees; feeder man on wood pulverizers, board and willow mat weavers and cabelee tiers on river work; deck hands; pile dike and revetment work; all laborers working on underground tunnels less than 25 ft. where compressed air is not used; abutement and pier hole men working six (6) ft. or more below ground; men working in coffer dams for bridge piers and footing in the river; barco tamper; jackson or any other similar tamp; cutting torch man; liners, curb, gutters, ditch lines; hot mastic kettlemen; hot tar applicator; hand blade operator; mortar men or brick or block manholes; rubbing concrete, air tool operator under 65 lbs.; caulker and lead man; chain or concrete saw under 15 h.p.; signal Gan; Guard rail and sign erectors.

GROUP 2 - Skilled laborers - Vibrator man; asphalt raker; head pipe layer on sewer work; batterboard man on pipe and ditch work; cliff scalers working from bosun's chairs; scaffolds or platforms on dams or power plants over 10 ft. high; air tool operator over 65 lbs.; stringline man on concrete paving; sandblast man; laser beam man; wagon drill; churn drill; air track drill and all other similar type drills, gunite nozzle man; pressure grout man; screed man on asphalt; concrete saw 15 h.p. and over; grade checker; strigline man on electronic grade control; manhole builder; dynamite man; powder man; welder; tunnel man; waterblaster - 1000 psi or over; asbestos and/or hazardous waste removal and/or disposal

-----  
 PAIN002-002 09/01/2007

CLARK, FRANKLIN, JEFFERSON, LEWIS, LINCOLN, MARION, PIKE, RALLS, ST. CHARLES, ST. LOUIS (CITY & COUNTY), AND WARREN COUNTIES

	Rates	Fringes
Painters:		
Brush and Roller; Taper.....	\$ 28.61	10.24
High work over 60 feet.....	\$ 29.11	10.24
Lead Abatement.....	\$ 29.36	10.24
Pressure Roller; High work under 60 ft.....	\$ 28.86	10.24
Spray & Abrasive Blasting; Water Blasting (Over 5000 PSI).....	\$ 30.61	10.24
Taper (Ames Tools & Bazooka).....	\$ 30.21	10.24

-----  
 PAIN002-006 04/01/2023

ADAIR, AUDRAIN, BOONE, CALLAWAY, CHARITON, COLE, GASCONADE, HOWARD, KNOX, LINN, MACON, MONROE, MONTGOMERY, OSAGE, PUTNAM, RANDOLPH, SCHUYLER, SCOTLAND, SHELBY AND SULLIVAN COUNTIES and the City of Booneville.

	Rates	Fringes
Painters:		
Bridges, Dams, Locks or Powerhouses.....	\$ 28.49	15.03
Brush and Roll; Taping,		



Paperhanging.....	\$ 26.49	15.03
Epoxy or Any Two Part Coating; Sandblasting; Stage or other Aerial Work - Platforms over 50 feet high; Lead Abatement.....	\$ 27.49	15.03
Spray; Structural Steel (over 50 feet).....	\$ 27.49	15.03
Tapers using Ames or Comparable Tools.....	\$ 27.24	15.03

-----  
PAIN003-004 04/01/2019

CASS, CLAY, CLINTON, JACKSON, JOHNSON, LAFAYETTE, PLATTE & RAY  
COUNTIES

Rates Fringes

Painters:

Bridgeman; Lead Abatement; Sandblast; Storage Bin & Tanks.....	\$ 33.41	17.76
Brush & Roller.....	\$ 30.54	17.76
Drywall.....	\$ 31.74	17.76
Paper Hanger.....	\$ 31.04	17.76
Stageman; Beltman; Stelman; Elevator Shaft; Bazooka, Boxes and Power Sander; Sprayman; Dipping...	\$ 32.41	17.76
Steeplejack.....	\$ 36.98	17.76

-----  
PAIN003-011 04/01/2019

BATES, BENTON, CALDWELL, CARROLL, COOPER, DAVIESS, GRUNDY,  
HARRISON, HENRY, LIVINGSTON, MERCER, MONITEAU, MORGAN, PETTIS &  
SALINE COUNTIES

Rates Fringes

Painters:

Bridgeman; Lead Abatement; Sandblast; Storage Bin & Tanks.....	\$ 26.73	17.76
Brush & Roller.....	\$ 24.43	17.76
Drywall.....	\$ 25.39	17.76
Paper Hanger.....	\$ 24.83	17.76
Stageman; Beltman; Stelman; Elevator Shaft;		

Bazooka, Boxes and Power Sander; Sprayman; Dipping...\$ 26.35	17.76
Steeplejack.....\$ 29.58	17.76

-----  
PAIN1185-008 04/01/2025

CAMDEN, CRAWFORD, DENT, LACLEDE, MARIES, MILLER, PHELPS,  
PULASKI AND TEXAS COUNTIES

	Rates	Fringes
Painters:		
Brush and Roller.....\$ 33.90		17.21
Floor Work.....\$ 34.90		17.21
Lead Abatement.....\$ 33.25		17.21
Spray.....\$ 34.90		17.21
Structural Steel, Sandblasting and All Tank Work.....\$ 35.90		17.21
Taping, Paperhanging.....\$ 34.90		17.21

-----  
PAIN1292-002 09/01/2024

BOLLINGER, BUTLER, CAPE GIRARDEAU, CARTER, DUNKLIN,  
MISSISSIPPI, NEW MADRID, OREGON, PEMISCOT, PERRY, REYNOLDS,  
RIPLEY, SCOTT, SHANNON, STODDARD and WAYNE COUNTIES

	Rates	Fringes
Painters:		
Bridges, Stacks & Tanks.....\$ 35.30		17.65
Brush & Roller.....\$ 29.80		17.65
Spray & Abrasive Blasting; Waterblasting (over 5000 PSI).....\$ 31.80		17.65

Height Rates (All Areas):  
Over 60 ft. \$0.50 per hour.  
Under 60 ft. \$0.25 per hour.

-----  
PAIN1292-003 09/01/2024

IRON, MADISON, ST. FRANCOIS, STE. GENEVIEVE and WASHINGTON  
COUNTIES

	Rates	Fringes
--	-------	---------

Painters:

Bridges, Stacks & Tanks.....	\$ 35.30	17.65
Brush & Roller.....	\$ 30.95	17.65
Spray & Abrasive Blasting; Waterblasting (Over 5000 PSI).....	\$ 32.95	17.65

Height Rates (All Areas):

Over 60 ft. \$0.50 per hour

Under 60 ft. \$0.25 per hour.

-----  
\* PAIN2012-001 04/01/2025

ANDREW, ATCHISON, BUCHANAN, DE KALB, GENTRY, HOLT, NODAWAY &  
WORTH COUNTIES

	Rates	Fringes
--	-------	---------

Painters:

Brush & Roller.....	\$ 36.18	19.97
Sandblaster.....	\$ 40.76	19.97
Steeplejack.....	\$ 44.33	19.97

-----  
PAIN2015-001 04/01/2012

BARRY, BARTON, CEDAR, CHRISTIAN, DADE, DALLAS, DOUGLAS, GREENE,  
HICKORY, HOWELL, JASPER, LAWRENCE, MCDONALD, NEWTON, OZARK,  
POLK, ST. CLAIR, STONE, TANEY, VERNON, WEBSTER, and WRIGHT  
COUNTIES

	Rates	Fringes
--	-------	---------

Painters:

Finisher.....	\$ 20.18	11.33
Painter.....	\$ 19.75	11.76
Sandblaster, High Man, Spray Man, Vinyl Hanger, Tool Operator.....	\$ 21.18	11.33

-----  
PLAS0518-006 03/01/2025

BARRY, BARTON, CEDAR, CHRISTIAN, DADE, DALLAS, DOUGLAS, GREENE,  
HICKORY, JASPER, LACLEDE, LAWRENCE, MCDONALD, NEWTON, OZARK,  
POLK, ST. CLAIR, STONE, TANEY, VERNON, WEBSTER, AND WRIGHT  
COUNTIES

	Rates	Fringes
CEMENT MASON/CONCRETE FINISHER...	\$ 30.37	12.43
-----		
PLAS0518-007 04/01/2025		

CASS (Richards-Gebaur AFB only), CLAY, JACKSON, PLATTE AND RAY COUNTIES

	Rates	Fringes
Cement Masons:.....	\$ 39.06	18.71
-----		
PLAS0518-011 04/01/2025		

ANDREW, ATCHISON, BATES, BUCHANNAN, CLINTON, DEKALB, GENTRY, HENRY, HOLT, JOHNSON, LAFAYETTE, NODAWAY & WORTH COUNTIES

	Rates	Fringes
CEMENT MASON/CONCRETE FINISHER...	\$ 40.13	20.50
-----		
PLAS0518-019 03/01/2025		

Adair, Audrain, Benton, Boone, Callaway, Caldwell, Camden, Carroll, Chariton, Cole, Cooper, Daviess, Gasconade, Grundy, Harrison, Howard, Linn, Livingston, Macon, Maries, Mercer, Miller, Moniteau, Monroe, Montgomery, Morgan, Osage, Pettis, Putnam, Randolph, Saline, Schuyler, Shelby and Sullivan Counties

	Rates	Fringes
CEMENT MASON/CONCRETE FINISHER...	\$ 33.52	15.88
-----		
PLAS0527-001 04/01/2023		

	Rates	Fringes
CEMENT MASON FRANKLIN, LINCOLN AND WARREN COUNTIES.....	\$ 37.29	20.23
JEFFERSON, ST. CHARLES COUNTIES AND ST. LOUIS (City and County).....	\$ 38.46	20.13
-----		
PLAS0527-004 06/01/2023		

CRAWFORD, DENT, IRON, MADISON, MARION, PHELPS, PIKE, PULASKI,  
 RALLS, REYNOLDS, ST. FRANCOIS, STE. GENEVIEVE, SHANNON, TEXAS,  
 WASHINGTON COUNTIES

	Rates	Fringes
CEMENT MASON.....	\$ 32.00	19.72
-----		
PLAS0908-001 05/01/2025		

BOLLINGER, BUTLER, CAPE GIRARDEAU, CARTER, DUNKLIN, HOWELL,  
 MISSISSIPPI, NEW MADRID, OREGON, PEMISCOT, PERRY, RIPLEY,  
 SCOTT, STODDARD, AND WAYNE COUNTIES

	Rates	Fringes
CEMENT MASON.....	\$ 35.10	18.78
-----		
PLUM0008-003 06/01/2024		

CASS, CLAY, JACKSON, JOHNSON, AND PLATTE COUNTIES

	Rates	Fringes
Plumbers.....	\$ 56.63	24.54
-----		
PLUM0008-017 06/01/2024		

BATES, BENTON, CARROLL, HENRY, LAFAYETTE, MORGAN, PETTIS, RAY,  
 ST. CLAIR, SALINE AND VERNON COUNTIES

	Rates	Fringes
Plumbers.....	\$ 56.63	24.54
-----		
PLUM0045-003 08/01/2024		

ANDREW, ATCHISON, BUCHANAN, CALDWELL, CLINTON, DAVIESS, DEKALB,  
 GENTRY, HARRISON, HOLT, NODAWAY AND WORTH COUNTIES

	Rates	Fringes
Plumbers and Pipefitters.....	\$ 47.45	26.15
-----		
PLUM0178-003 11/01/2024		

BARRY, CEDAR, CHRISTIAN, DADE, DALLAS, DOUGLAS, GREENE,  
 HICKORY, LACLEDE, LAWRENCE, POLK, STONE, TANEY, WEBSTER AND  
 WRIGHT COUNTIES

	Rates	Fringes
Plumbers and Pipefitters.....	\$ 39.35	15.72
-----		
PLUM0178-006 11/01/2022		

BARTON, JASPER, MCDONALD AND NEWTON COUNTIES

	Rates	Fringes
Plumbers and Pipefitters		
Projects \$750,000 & under....	\$ 32.78	15.32
Projects over \$750,000.....	\$ 35.75	15.32
-----		
PLUM0533-004 06/01/2024		

BATES, BENTON, CARROLL, CASS, CLAY, HENRY, HICKORY, JACKSON,  
 JOHNSON, LAFAYETTE, MORGAN, PETTIS, PLATTE, RAY, SALINE, ST.  
 CLAIR AND VERNON COUNTIES

	Rates	Fringes
Pipefitters.....	\$ 55.56	25.80
-----		
PLUM0562-004 07/01/2023		

ADAIR, AUDRAIN, BOLLINGER, BOONE, BUTLER, CALLAWAY, CAMDEN, CAPE  
 GIRARDEAU, CARTER, CHARITON, CLARK, COLE, COOPER, CRAWFORD,  
 DENT, DUNKLIN, FRANKLIN, GASCONADE, GRUNDY, HOWARD, HOWELL,  
 IRON, JEFFERSON, KNOX, LEWIS, LINCOLN, LINN, LIVINGSTON, MACON,  
 MADISON, MARIES, MARION, MERCER, MILLER, MISSISSIPPI, MONITEAU,  
 MONROE, MONTGOMERY, NEW MADRID, OREGON, OSAGE, PEMISCOTT,  
 PERRY, PHELPS, PIKE, PULASKI, PUTNAM, RALLS, RANDOLPH,  
 REYNOLDS, RIPLEY, ST. CHARLES, ST. FRANCOIS, STE. GENEVIEVE, ST.  
 LOUIS, SCHUYLER, SCOTLAND, SCOTT, SHANNON, SHELBY, STODDARD,  
 SULLIVAN, TEXAS, WARREN, WASHINGTON, AND WAYNE COUNTIES.

	Rates	Fringes
Plumbers and Pipefitters		
Mechanical Contracts		
including all piping and		

temperature control work \$7.0 million & under.....	\$ 46.66	21.99
Mechanical Contracts including all piping and temperature control work over \$7.0 million.....	\$ 46.66	21.99

-----  
 PLUM0562-016 07/01/2023

CAMDEN, COLE, CRAWFORD, FRANKLIN, JEFFERSON, MARIES, MILLER,  
 MONITEAU, OSAGE, PHELPS, PULASKI, ST. CHARLES, ST. LOUIS (City  
 and County), WARREN and WASHINGTON COUNTIES

	Rates	Fringes
Plumbers		
Mechanical Contracts including all piping and temperature control work \$7.0 million & under.....	\$ 46.66	21.99
Mechanical Contracts including all piping and temperature control work over \$7.0 million.....	\$ 46.66	21.99

-----  
 TEAM0013-001 05/01/2025

	Rates	Fringes
Truck drivers (ADAIR, BUTLER, CLARK, DUNKIN, HOWELL, KNOX, LEWIS, OREGON, PUTNAM, RIPLEY, SCHUYLER AND SCOTLAND COUNTIES)		
GROUP 1.....	\$ 35.84	15.85
GROUP 2.....	\$ 35.99	15.85
GROUP 3.....	\$ 36.11	15.85
GROUP 4.....	\$ 35.74	15.85

Truck drivers (AUDRAIN,  
 BOLLINGER, BOONE, CALLAWAY,  
 CAPE GIRARDEAU, CARTER, COLE,  
 CRAWFORD, DENT, GASCONADE,  
 IRON, MACON, MADISON, MARIES,  
 MARION, MILLER, MISSISSIPPI,  
 MONROE, MONTGOMERY, NEW  
 MADRID, OSAGE, PEMISCOT,  
 PERRY, PHELPS, PIKE, PULASKI,  
 RALLS, REYNOLDS, ST.  
 FRANCOIS, STE. GENEVIEVE,

SCOTT, SHANNON, SHELBY,  
 STODDARD, TEXAS, WASHINGTON  
 AND WAYNE COUNTIES)

GROUP 1.....	\$ 36.57	15.85
GROUP 2.....	\$ 36.72	15.85
GROUP 3.....	\$ 36.84	15.85
GROUP 4.....	\$ 36.73	15.85

Truck drivers (FRANKLIN,  
 JEFFERSON and ST. CHARLES  
 COUNTIES)

GROUP 1.....	\$ 38.93	15.85
GROUP 2.....	\$ 39.08	15.85
GROUP 3.....	\$ 39.15	15.85
GROUP 4.....	\$ 39.04	15.85

Truck drivers (LINCOLN and  
 WARREN COUNTIES)

GROUP 1.....	\$ 37.58	15.85
GROUP 2.....	\$ 38.73	15.85
GROUP 3.....	\$ 37.80	15.85
GROUP 4.....	\$ 37.69	15.85

TRUCK DRIVERS CLASSIFICATIONS:

GROUP 1: Flat Bed Trucks, Single Axle; Station Wagons;  
 Pickup Trucks; Material Trucks, Single Axle; Tank Wagon,  
 Single Axle

GROUP 2: Agitator and Transit Mix Trucks

GROUP 3: Flat Bed Trucks, Tandem Axle; Articulated Dump  
 Trucks; Material Trucks, Tandem Axle; Tank Wagon, Tandem  
 Axle

GROUP 4: Semi and/or Pole Trailers; Winch, Fork & Steel  
 Trucks; Distributor Drivers and Operators; Tank Wagon,  
 Semi-Trailer; Insley Wagons, Dumpsters, Half-Tracks,  
 Speedace, Euclids and other similar equipment; A-Frame and  
 Derrick Trucks; Float or Low Boy

-----  
 TEAM0056-001 05/01/2025

Rates Fringes

Truck drivers (ANDREW,  
 BARTON, BATES, BENTON,  
 CALDWELL, CAMDEN, CARROLL,  
 CEDAR, CHARITON, CHRISTIAN,  
 CLINTON, COOPER, DADE,  
 DALLAS, DAVIESS, DEKALB,



DOUGLAS, GREENE, HENRY,  
 HICKORY, HOWARD, JASPER,  
 LACLEDE, LAWRENCE, LINN,  
 LIVINGSTON, MONITEAU, MORGAN,  
 NEWTON, PETTIS, POLK,  
 RANDOLPH, ST. CLAIR, SALINE,  
 VERNON, WEBSTER AND WRIGHT  
 COUNTIES)

GROUP 1.....	\$ 36.27	15.85
GROUP 2.....	\$ 36.43	15.85
GROUP 3.....	\$ 36.42	15.85
GROUP 4.....	\$ 36.54	15.85

Truck drivers: (ATCHISON,  
 BARRY, GENTRY, GRUNDY,  
 HARRISON, HOLT, MCDONALD,  
 MERCER, NODAWAY, OZARK,  
 STONE, SULLIVAN, TANEY AND  
 WORTH COUNTIES)

GROUP 1.....	\$ 35.54	15.85
GROUP 2.....	\$ 35.70	15.85
GROUP 3.....	\$ 35.69	15.85
GROUP 4.....	\$ 35.81	15.85

Truck drivers; (BUCHANAN,  
 JOHNSON AND LAFAYETTE  
 COUNTIES)

GROUP 1.....	\$ 35.93	15.75
GROUP 2.....	\$ 36.04	15.75
GROUP 3.....	\$ 36.08	15.75
GROUP 4.....	\$ 36.08	15.75

TRUCK DRIVER CLASSIFICATIONS

GROUP 1: Flat bed trucks single axle; station wagons; pickup trucks; material trucks single axle; tank wagons single axle.

GROUP 2: Agitator and transit mix-trucks.

GROUP 3: Flat bed trucks tandem axle; articulated dump trucks; material trucks tandem axle; tank wagons tandem axle.

GROUP 4: Semi and/or pole trailers; winch, fork & steel trucks; distributor drivers & operators; tank wagons semi-trailer; insley wagons, dumpsters, half-tracks, speedace, euclids & other similar equipment; A-frames and derrick trucks; float or low boy.

-----  
 TEAM0245-001 03/26/2012

BARRY, BARTON, CAMDEN, CEDAR, CHRISTIAN, DALLAS, DENT, DOUGLAS,  
 GREENE, HICKORY, HOWELL, JASPER, LACLEDE, LAWRENCE, MCDONALD,  
 MILLER, NEWTON, OZARK, PHELPS, POLK, PULASKI, SHANNON, STONE,  
 TANEY, TEXAS, VERNON, WEBSTER AND WRIGHT COUNTIES

	Rates	Fringes
Truck drivers:		
Traffic Control Service		
Driver.....	\$ 20.45	0.00

PAID HOLIDAYS: New Year's Day, Decoration Day, July 4th,  
 Labor Day, Thanksgiving Day, Christmas Day, employee's  
 birthday and 2 personal days.

-----  
 TEAM0541-001 04/01/2025

CASS, CLAY, JACKSON, PLATTE AND RAY COUNTIES

	Rates	Fringes
Truck drivers:		
GROUP 1.....	\$ 38.61	15.85
GROUP 2.....	\$ 38.04	15.85
GROUP 3.....	\$ 37.52	15.85

TRUCK DRIVERS CLASSIFICATIONS

GROUP 1: Mechanics and Welders, Field; A-Frame Low Boy-Boom  
 ruck Driver.

GROUP 2: Articulated Dump Truck; Insley Wagons: Dump Trucks,  
 Excavating, 5 cu yds and over; Dumpsters; Half-Tracks:  
 Speedace: Euclids & similar excavating equipment Material  
 trucks, Tandem Two teams; Semi-Trailers; Winch trucks-Fork  
 trucks; Distributor Drivers and Operators; Agitator and  
 Transit Mix; Tank Wagon Drivers, Tandem or Semi; One Team;  
 Station Wagons; Pickup Trucks; Material Trucks, Single  
 Axle; Tank Wagon Drivers, Single Axle

GROUP 3: Oilers and Greasers - Field

-----  
 TEAM0682-002 05/01/2025

ST LOUIS CITY AND COUNTY

	Rates	Fringes
Truck drivers:		
GROUP 1.....	\$ 37.83	9.85+a+b+c
GROUP 2.....	\$ 37.83	9.85+a+b+c
GROUP 3.....	\$ 37.83	9.85+a+b+c

a. PENSION: 5/1/2012 - \$182.20 per week.

b. HAZMAT PREMIUM: If Hazmat certification on a job site is required by a state or federal agency or requested by project owner or by the employer, employees on that job site shall receive \$1.50 premium pay.

#### TRUCK DRIVERS CLASSIFICATIONS

GROUP 1 - Pick-up trucks; forklift, single axle; flatbed trucks; job site ambulance, and trucks or trailers of a water level capacity of 11.99 cu. yds. or less

GROUP 2 - Trucks or trailers of a water level capacity of 12.0 cu yds. up to 22.0 cu yds. including euclids, speedace and similar equipment of same capacity and compressors

GROUP 3 - Trucks or trailers of a water level capacity of 22.0 cu. yds & over including euclids, speedace & all floats, flatbed trailers, boom trucks, winch trucks, including small trailers, farm wagons tilt-top trailers, field offices, tool trailers, concrete pumps, concrete conveyors & gasoline tank trailers and truck mounted mobile concrete mixers

#### FOOTNOTE FOR TRUCK DRIVERS:

c. PAID HOLIDAYS: Christmas Day, Independence Day, Labor Day, Memorial Day, Veterans Day, New Years Day, Thanksgiving Day

d. PAID VACATION: 3 days paid vacation for 600 hours of service in any one contract year; 4 days paid vacation for 800 hours of service in any one contract year; 5 days paid vacation for 1,000 hours of service in any one contract year. When such an employee has completed 3 years of continuous employment with the same employer and then works the above required number of hours, he shall receive double the number of days of vacation specified above. When such an employee has completed 10 years of continuous employment with the same employer and then works the above required number of hours, he shall receive triple the number of days of vacation specified above. When such an employee has

completed 15 years of continuous employment with the same employer and then works the above required number of hours, he shall receive 4 times the number of days of vacation specified above.

-----

WELDERS - Receive rate prescribed for craft performing operation to which welding is incidental.

=====

Note: Executive Order (EO) 13706, Establishing Paid Sick Leave for Federal Contractors applies to all contracts subject to the Davis-Bacon Act for which the contract is awarded (and any solicitation was issued) on or after January 1, 2017. If this contract is covered by the EO, the contractor must provide employees with 1 hour of paid sick leave for every 30 hours they work, up to 56 hours of paid sick leave each year. Employees must be permitted to use paid sick leave for their own illness, injury or other health-related needs, including preventive care; to assist a family member (or person who is like family to the employee) who is ill, injured, or has other health-related needs, including preventive care; or for reasons resulting from, or to assist a family member (or person who is like family to the employee) who is a victim of, domestic violence, sexual assault, or stalking. Additional information on contractor requirements and worker protections under the EO is available at <https://www.dol.gov/agencies/whd/government-contracts>.

Unlisted classifications needed for work not included within the scope of the classifications listed may be added after award only as provided in the labor standards contract clauses (29CFR 5.5 (a) (1) (iii)).

-----

The body of each wage determination lists the classifications and wage rates that have been found to be prevailing for the type(s) of construction and geographic area covered by the wage determination. The classifications are listed in alphabetical order under rate identifiers indicating whether the particular rate is a union rate (current union negotiated rate), a survey rate, a weighted union average rate, a state adopted rate, or a supplemental classification rate.

Union Rate Identifiers

A four-letter identifier beginning with characters other than ""SU"", ""UAVG"", ?SA?, or ?SC? denotes that a union rate was prevailing for that classification in the survey. Example: PLUM0198-005 07/01/2024. PLUM is an identifier of the union whose collectively bargained rate prevailed in the survey for this classification, which in this example would be Plumbers. 0198 indicates the local union number or district council number where applicable, i.e., Plumbers Local 0198. The next number, 005 in the example, is an internal number used in processing the wage determination. The date, 07/01/2024 in the example, is the effective date of the most current negotiated rate.

Union prevailing wage rates are updated to reflect all changes over time that are reported to WHD in the rates in the collective bargaining agreement (CBA) governing the classification.

#### Union Average Rate Identifiers

The UAVG identifier indicates that no single rate prevailed for those classifications, but that 100% of the data reported for the classifications reflected union rates. EXAMPLE: UAVG-OH-0010 01/01/2024. UAVG indicates that the rate is a weighted union average rate. OH indicates the State of Ohio. The next number, 0010 in the example, is an internal number used in producing the wage determination. The date, 01/01/2024 in the example, indicates the date the wage determination was updated to reflect the most current union average rate.

A UAVG rate will be updated once a year, usually in January, to reflect a weighted average of the current rates in the collective bargaining agreements on which the rate is based.

#### Survey Rate Identifiers

The ""SU"" identifier indicates that either a single non-union rate prevailed (as defined in 29 CFR 1.2) for this classification in the survey or that the rate was derived by computing a weighted average rate based on all the rates reported in the survey for that classification. As a weighted average rate includes all rates reported in the survey, it may include both union and non-union rates. Example: SUFL2022-007 6/27/2024. SU indicates the rate is a single non-union prevailing rate or a weighted average of survey data for that classification. FL indicates the State of Florida. 2022 is the year of the survey on which these classifications and rates are based. The next number, 007 in the example, is an internal number used in producing the wage determination. The date, 6/27/2024 in the example, indicates the survey completion date

for the classifications and rates under that identifier.

?SU? wage rates typically remain in effect until a new survey is conducted. However, the Wage and Hour Division (WHD) has the discretion to update such rates under 29 CFR 1.6(c)(1).

#### State Adopted Rate Identifiers

The ""SA"" identifier indicates that the classifications and prevailing wage rates set by a state (or local) government were adopted under 29 C.F.R 1.3(g)-(h). Example: SAME2023-007 01/03/2024. SA reflects that the rates are state adopted. ME refers to the State of Maine. 2023 is the year during which the state completed the survey on which the listed classifications and rates are based. The next number, 007 in the example, is an internal number used in producing the wage determination. The date, 01/03/2024 in the example, reflects the date on which the classifications and rates under the ?SA? identifier took effect under state law in the state from which the rates were adopted.

-----

#### WAGE DETERMINATION APPEALS PROCESS

1) Has there been an initial decision in the matter? This can be:

- a) a survey underlying a wage determination
- b) an existing published wage determination
- c) an initial WHD letter setting forth a position on a wage determination matter
- d) an initial conformance (additional classification and rate) determination

On survey related matters, initial contact, including requests for summaries of surveys, should be directed to the WHD Branch of Wage Surveys. Requests can be submitted via email to [davisbaconinfo@dol.gov](mailto:davisbaconinfo@dol.gov) or by mail to:

Branch of Wage Surveys  
Wage and Hour Division  
U.S. Department of Labor  
200 Constitution Avenue, N.W.  
Washington, DC 20210

Regarding any other wage determination matter such as conformance decisions, requests for initial decisions should be directed to the WHD Branch of Construction Wage Determinations. Requests can be submitted via email to [BCWD-Office@dol.gov](mailto:BCWD-Office@dol.gov) or

by mail to:

Branch of Construction Wage Determinations  
Wage and Hour Division  
U.S. Department of Labor  
200 Constitution Avenue, N.W.  
Washington, DC 20210

2) If an initial decision has been issued, then any interested party (those affected by the action) that disagrees with the decision can request review and reconsideration from the Wage and Hour Administrator (See 29 CFR Part 1.8 and 29 CFR Part 7). Requests for review and reconsideration can be submitted via email to [dba.reconsideration@dol.gov](mailto:dba.reconsideration@dol.gov) or by mail to:

Wage and Hour Administrator  
U.S. Department of Labor  
200 Constitution Avenue, N.W.  
Washington, DC 20210

The request should be accompanied by a full statement of the interested party's position and any information (wage payment data, project description, area practice material, etc.) that the requestor considers relevant to the issue.

3) If the decision of the Administrator is not favorable, an interested party may appeal directly to the Administrative Review Board (formerly the Wage Appeals Board). Write to:

Administrative Review Board  
U.S. Department of Labor  
200 Constitution Avenue, N.W.  
Washington, DC 20210.

=====

END OF GENERAL DECISION"

This RER has been completed, only administrators may edit this document now, they will contact you if any information changes.

Date Completed: 08/15/2025  
Completed By: Holly Cantrell

## Request for Environmental Review Form#:2025-10-00093

Alternative Project Delivery Method (such as Design/Build)

### ~Project Information

Prefix:	TAP	Project Number:	9901313	Bridge Number:	
District:	Central District	County:		Sponsor:	Doug Reese
				Sponsor Email:	rdoug48@gmail.com
TIP Number:		Rte/Street:	Carel Rd, Henwick Ln		
MoDOT Job Number:		TIGER Grant Funds:		Is this project on or adjacent to MoDOT Right of Way:	No
Location/Stream Crossing :	NONE				
TMS Project Description - termini (no stations):	CITY OF ST. MARTINS; COLE CO; SIDEWALK CONSTRUCTION ON Bus 50 AND Carel N to Henwick				
Describe RER project improvements in full detail:	Approximately 3400 LF of 6-ft wide sidewalk on W side of Carel Rd from Bus 50 W to Henwick Ln and S/E side of Henwick Ln from Carel Rd to Bus 50 W; approximately 1400 LF of curb and gutter at locations of sidewalk where none currently exists; storm/drainage improvements and relocation of utilities as needed.				
District Liaison:	Joanie Prenger - 573-751-7399	Contact:	None selected		
Email:	Joanie.Prenger@modot.mo.gov	Email:			
Contact:	None selected	Contact:	None selected		
Email:		Email:			
Date Desired:	12/08/2024	Submit Date:	11/08/2024		
Desired A-Date:					
Responsible Individual:	Brian Williams - (10/21/2024 9:26:43 AM) - 573-636-3303	Submitted By:	Brian Williams - (11/8/2024 12:00:00 AM) - 573-636-3303		
<b>Existing Condition</b>					
ADT:	300	Speed Limit:	30		
Number of Travel Lanes:	2	Lane Width:	Varies, 10'-14'		
Shoulder Width:	0	Curb and Gutter:	No		
Bridge width, measured from gutterline to gutterline:	N/A	Sidewalks:	None		
<b>Proposed Design Improvement</b>					
ADT:	≥300	Speed Limit:	30	Design Speed:	30
Number of Travel Lanes:	2	Lane Width:	Varies, 10'-14'		
Shoulder Width:	0	Curb and Gutter:	Yes		
Bridge width, measured from gutterline to gutterline:	N/A	Sidewalks:	Left		
Bridge Length:	N/A	Roadway length:	3400'		
Railroad Crossing:	No	Drainage District (If Applicable):	Central District		
<b>Program Year:</b>					
Preliminary Engineering:	2025	Right of Way:	2025		



Construction: 2025

Has the sponsor documented that the project has:

- 1. Independent utility,
- 2. Logical termini, and
- 3. Does not restrict consideration of alternatives for other reasonably foreseeable transportation improvements?:

Project breakout from previous or larger project? *If checked explain:*

### Acres - From all sources (e.g. donated from public or private entities):

Additional R/W (acres): 0      Temp Easement (acres): 0      Permanent Easement (acres): 0

ROW may be needed, but, not yet determined? Yes

Is ANY Federally-owned land impacted by the project?  Yes  No

### Land Disturbance:

Will project involve 1 acre or more? Yes

Acres of Tree Clearing: 0.05 acres

DO NOT CLEAR TREES W/O MODOT'S PRIOR WRITTEN APPROVAL.

### Number of Displacements(do not include partial takes that do not displace):

Residential:  Yes  No

Commercial:  Yes  No

No. of People:

Residences:

No. of Employees:

Businesses:

### Any Public Involvement planned or completed:

Yes 8/14/2025 - A public hearing was held by the City of St. Martins on 8/12/2025 at City Hall. The advertisement on the social media site as well as personal notification by the Mayer to the adjoining property owners, meeting minutes, and the sign in sheet have been uploaded to the RER.

### Average Daily Traffic:

ADT Construction Year: ≥300

ADT Design Year: ≥300

### Traffic Impacts:

Road Closure Planned:  Yes  No

Bridge Closure Planned:  Yes  No

Days/Months Closed:

Detour > 25 mi rural (including local roads)  Yes  No

Detour > 5 mi urban (including local roads, census defined urban)  Yes  No

Detour Info:

### Bicycle / Pedestrian Consideration

Pedestrian facilities considered: Yes

Bicycle facilities considered: Yes

### National Flood Insurance Program (NFIP) and Hydraulic Design Data:

Project involves land purchased through FEMA Hazard Mitigation Grant Program (Flood buyout property)

*If checked, give details:*

Is ANY construction taking place on MoDOT owned property under this project?

Yes  No

Is highway improvement located within 4 miles of an existing airport?

**Known Concerns: Provide information you have about these resources that you have observed in the area.**

- Parkland:** No parkland exists within the project limits.
- Wetland/404 Permit:** No wetlands or jurisdictional waterways are located within the project limits.
- Land Disturbance / Stormwater:** SWPPP will be required, DNR land disturbance permit will be applied for if necessary after final determination of disturbed areas.
- Farmland:** No impact to farmland anticipated, project limits are entirely within City limits.
- Threatened & Endangered Species:** No impact to threatened & endangered species is anticipated; all tree clearing will take place in areas with no suitable bat habitat/roost trees.
- Migratory Birds: Are there birds nesting on the structure?**  Unknown  Yes  No  
No bridges, box culverts, water crossings, or other structures with suitable migratory bird habitat exist within the project limits. No impact to migratory birds is anticipated.
- Hazardous Waste:** No hazardous waste is known to be present within project limits.
- Cultural Resources:** No cultural resources are known to be present within project limits.

LPA Comments:

**Project Attachments:**

**\*\*NOTE: If making updates to an attachment, please use a different filename than the original.**

**\*\*The combined size of attachments in one upload must be less than 100MB**

**Attachments:**

- TAP9901-313\_Public\_Hearing\_Sign-in-sheet\_8-12-2025.pdf
- City of St. Martins advertising of Public hearing.pdf
- BOARD MEETING AUGUST 12 2025.pdf
- NHRR Follow-up.pdf
- Photos of Trees to be Cleared.pdf
- 16450 SITE PLAN 2025-3-6.pdf
- TEMemo.pdf
- T&E Checklist.pdf
- 2025-10-00093 Tree Clearing Limits.kmz
- 16450 Project Limits.pdf
- Species List\_Missouri Ecological Services Field Office.pdf
- project\_report\_st\_martins\_carel\_henw\_70756\_72471\_FINAL.pdf

**Required Information to be attached for each RER stage:**

- Cost-Share agreement, if applicable

- **Funding Application**
- Location map (county map, topographic map or aerial map) showing the project limits
- plan sheets as the become available
- KMZ file showing project area/study area and tree clearing limits
- Permits/documentation as required (floodplain, farmland form, NWP, asbestos & lead based paint inspection reports, Section 106 report, RCI and CRIR forms, SHPO concurrence letter, USFWS IPac Official Species List, MDC Heritage Review Report, Effects determination)

## RER Environmental Screenings

### Farmland Impact Status: N/A

Status Information:  N/A  Pending  Cleared Clearance Date:

Environmental Response: The project is within an existing urban development area and, therefore is not subject to the FPPA. Though the project is not entirely within an urbanized area as defined by the U.S. Census Bureau Urban Area Reference Map, the City of St. Martin's is considered an urban development area due to its density of 30 structures per 40-acre area. Therefore, the project is not subject to the Farmland Protection Policy Act.

LPA Action:

#### Attachments:

- Farmland Impact Submitted - Mark submitted when this review is ready to be sent to district staff.  
Last Updated: Aaron Stolte - 11/22/2024 11:35:46 AM

### Floodplain/Regulatory Floodway Status: N/A

Status Information:  N/A  Pending  Cleared Clearance Date:

Environmental Response: According to the attached FEMA floodplain map, the project is not located in the 100-year floodplain or the regulatory floodway. The project is not subject to floodplain permitting requirements.

LPA Action:

#### Attachments:

[FEMA NFP RER\\_2025-10-00093.png](#)

[FEMA FIRMETTE\\_29051C0105E.png](#)

[FEMA Firm\\_2025-10-00093.pdf](#)

- Floodplain/Regulatory Floodway Submitted - Mark submitted when this review is ready to be sent to district staff.  
Last Updated: Aaron Stolte - 11/22/2024 11:36:02 AM

### Land Disturbance / Stormwater Status: N/A

Status Information:  N/A  Possible Issues Noted Clearance Date:

Environmental Response: If the project is in a regulated MS4 area, adhere to the MS4 requirements as defined in the MS4 permit specific to that municipality. Stormwater routed into MoDOT's drainage system (e.g., ditches and stormwater conveyance systems) must be treated for water quality and/or quantity before entering the system. Any project with land disturbance of 1-acre or more requires a NDPEs land disturbance permit from MDNR.

LPA Action: If the project will disturb 1-acre or more of land, obtain a NPDES land disturbance permit from DNR. The LPA must also implement best management practices in accordance with that permit and the Clean Water Act.

#### Attachments:

- Land Disturbance / Stormwater Submitted - Mark submitted when this review is ready to be sent to district staff.  
Last Updated: Aaron Stolte - 11/22/2024 11:36:07 AM

### FEMA/SEMA Buyout Status: N/A

Status Information:  N/A  Pending  Cleared Clearance Date:

Environmental Response: According to the ArcMap GIS FEMA buyout layer, there are no flood buyout properties in the vicinity of the project. The project will not result in development on any FEMA buyout properties.

LPA Action: None

#### Attachments:

- FEMA/SEMA Buyout Submitted - Mark submitted when this review is ready to be sent to district staff.  
Last Updated: Aaron Stolte - 11/22/2024 11:36:19 AM

## Socioeconomic Impact

Status: Cleared

Status Information:  N/A  Pending  Cleared Clearance Date:  
08/14/2025

Environmental Response: 8/14/2025 UPDATE: The consultant uploaded (BOARD MEETING AUGUST 12 2025.pdf), (City of St. Martins advertising of Public hearing.pdf), and (TAP9901-313\_Public\_Hearing\_Sign-in-sheet\_8-12-2025.pdf) which show public involvement and notice of construction, as well as a sign in sheet and meeting minutes. This section can now be cleared. INITIAL SCREENING: The project does not require commercial or residential displacements; however, the project does require new right of way/temporary easements/permanent easements that are subject to the Uniform Relocation Assistance and Real Property Acquisition Policies Act of 1970, as amended. Road closures and detours will not be necessary during construction. Based on a review of EJSCREEN, no minority (people of color), low-income, or limited English Proficiency (LEP) populations were identified within the project area. There are no significant socioeconomic impacts associated with this project. Impacts will be temporary and limited to traffic disruptions, construction noise, and fugitive dust and emissions in the area of project construction. Additional detail on public involvement is required to clear this section.

LPA Action: 1. Conduct the acquisition of affected properties in accordance with the procedures established in the Uniform Relocation Assistance and Real Property Acquisition Policies Act of 1970, as amended. 2. Provide sufficient public notice of construction work and traffic management plans consistent with MoDOT's and local public involvement policies and procedures. 3. Public involvement is required for all MoDOT projects. See MoDOT EPG for more information: [https://epg.modot.org/index.php/Category:129\\_Public\\_Involvement](https://epg.modot.org/index.php/Category:129_Public_Involvement). For a low impact project such as this, routine methods such as social media, news releases, opportunity for meetings, etc. could be appropriate forms of public involvement. Provide information on how the public will be notified of the proposed project. Once the planned public engagement has occurred, please upload documentation of that engagement and include any meeting minutes and any materials presented on this project, as well as any sign-in sheets, any comments received, and any responses to those comments.

### Attachments:

Socioeconomic Impact Submitted - *Mark submitted when this review is ready to be sent to district staff.*

*Last Updated: Mackenzie Ressel - 8/14/2025 4:25:10 PM*

Threatened & Endangered Species Status: Cleared

Status Information:  No Effect  Pending  Cleared Clearance Date: 04/02/2025

Environmental Response: 4/2/2025 UPDATE: MoDOT has completed the T&E species review for the City of St. Martins sidewalk construction along Carel Road and Henwick Lane in Cole County, Missouri [TAP-9901(313)]. A copy of the effects determination document is uploaded to the TE section of the RER. The USFWS IPaC lists the following species for the project area: gray bat, Indiana bat, northern long-eared bat, monarch butterfly (proposed threatened), and western regal fritillary (proposed threatened). There are no critical habitats located within the project limits. Natural Heritage records indicate no known state ranked or state listed species within 1 mile of the project area. MoDOT has determined that there are no impacts to state-listed species as a result of the project. The project will not impact any known caves or suitable bat-roosting structures. Tree clearing is anticipated in association with the project, however, based on a review of site photos and Google Earth imagery, MoDOT has determined the trees to be removed as a result of the project do not provide suitable summer roosting habitat. The project does not include native prairie or marsh wetlands. As the designated non-federal representative of FHWA for USFWS Section 7 ESA requirements, MoDOT has determined the project will have No Effect on the gray bat, Indiana bat, and northern long-eared bat. The project will not jeopardize the continued existence of the proposed monarch butterfly and western regal fritillary. This completes the TE requirements for the project. 3/17/2025 UPDATE: The LPA has uploaded site plans and site photos showing trees that will be removed. At this time, all requested items have been received. MoDOT will prepare an effects determination memo. MoDOT may reach out with follow up questions throughout this process. INITIAL SCREENING: Impacts to threatened and endangered species must be assessed for this project. The LPA has uploaded an initial Level 3 MDC letter, an IPaC official species letter, a written determination of project impacts on each species listed from the IPaC/MDC, and a kmz of the tree clearing limits. Please note that photographs of the proposed trees to be cleared and a site plan is still required for MoDOT to draft a determination memo.

LPA Action: COMPLETED 1. Access the US Fish and Wildlife Service (USFWS) IPAC online tool at <http://ecos.fws.gov/ipac/> to obtain the official list of species for your county. 2. Access the MO Department of Conservation (MDC) online Natural Heritage Review website at <https://naturalheritagereview.mdc.mo.gov/> and generate a report. Contact MDC if the report indicates to do so. Submit the report, and MDC response, if required, to MoDOT. 3. Provide the amount, location, and time of year for tree clearing, or indicate there will be no tree clearing. 4. It is the responsibility of the LPA to make a written determination of their project impacts on each species listed from the IPaC. Further, the LPA must assess effects on any MDC listed species (endangered or species of conservation concern). If no effects are anticipated for a particular species, state the reason(s) why. For example: This project does not involve any tree clearing so there will be no effects on summer roosting habitat for listed bat species or this project does not impact any aquatic habitats so there will be no effects on listed fish or mussel species. 5. If there will be tree clearing, photograph the trees so that bark characteristics of the main trunk and large branches, along with any cavities, are clearly illustrated. 6. If the project involves bridgework, photograph the undersides of bridges illustrating any bird nests or unusual staining on the substructure or underside of the deck. (N/A) 7. Submit the full project limits, easements, access, construction date, and ground disturbance information.

- Attachments:
- [TE Complete - No Effect TAP-9901\(313\) City of St. Martins Sidewalk Construction along Carel Road and Henwick Lane in Cole County, Missouri.eml](#)
  - [TAP-9901313\\_MoDOT-Effects-Determination\\_Cole-County\\_Carel-Rd-Henwick-Ln-Sidewalk-Construction-St.-Martins\\_FINAL.pdf](#)

Threatened & Endangered Species Submitted - *Mark submitted when this review is ready to be sent to district staff.*  
Last Updated: Cassie Baumgartner - 4/2/2025 10:11:25 AM

Migratory Birds Status: N/A

Status Information:  N/A  Pending  Cleared Clearance Date:

Environmental Response: The sponsor has confirmed that the project will not impact bridges or other structures. Based on this information, there are no concerns related to migratory birds and no conflicts with the MBTA.

LPA Action:

- Attachments:
- Migratory Birds Submitted - *Mark submitted when this review is ready to be sent to district staff.*  
Last Updated: Aaron Stolte - 11/22/2024 11:39:32 AM

**Hazardous Waste Impact** Status: N/A

Status Information:  N/A  Pending  Cleared Clearance Date:

Environmental Response: According to the attached DNR E-START map, there are no Hazardous Substance Investigation and Cleanup Sites and no Regulated Petroleum and Hazardous Substance Storage Tank Facilities in the vicinity of the project area. There are no hazardous waste site concerns based on this information. However, the potential to encounter hazardous wastes from sites unknown to the LPA and MoDOT should always be a consideration.

LPA Action: If there is any hydroblasting, grooving, milling or diamond grinding related to the project, residue and associated water must be prevented from being released to waterways or adjacent wetlands. Any hazardous waste sites that are found during project construction will be addressed by the LPA sponsor in accordance with Federal and State Laws and Regulations. If any hazardous waste concerns arise, notify MoDOT's environmental specialist as soon as possible.

**Attachments:**

[DNR E-Start\\_2025-10-00093.png](#)

Hazardous Waste Impact Submitted - Mark submitted when this review is ready to be sent to district staff.

Last Updated: Aaron Stolte - 11/22/2024 11:39:41 AM

**Wetland Impact (Section 404/401)** Status: N/A

Status Information:  N/A  Pending  Cleared Clearance Date:

Environmental Response: According to the attached USFWS National Wetlands Inventory map, and Google Earth imagery, there are no wetlands, blue line streams, lakes, ponds, or other waters of the U.S. in or around the project area. The project is not anticipated to impact wetlands or waters of the U.S.

LPA Action: None

Wetland Permit Information:	404 Permit Number	Permit Submitted	Permit Received
	Permit Expiration	Compliance Certification Sent	Compliance Certification Received

**Attachments:**

[NWI RER 2025-10-00093.pdf](#)

Wetland Impact Submitted - Mark submitted when this review is ready to be sent to district staff.

Last Updated: Aaron Stolte - 11/22/2024 11:42:58 AM

**Noise Impact** Status: N/A

Status Information:  N/A  Pending  Cleared Clearance Date:

Environmental Response: This is a Type III project and a noise analysis is not required.

LPA Action:

**Attachments:**

Noise Impact Submitted - Mark submitted when this review is ready to be sent to district staff.

Last Updated: Aaron Stolte - 11/22/2024 12:40:04 PM

Cultural Resources Impact (Section 106/Historic 4f)

Status: Cleared

Section 106 Status:  Pending  Cleared

Section 106 SHPO

Submission Date:

Clearance Date:

04/03/2025

Project Specific Agreement Document:

N/A  PA  MOA

Select Programmatic Agreements Used:

First Choice:

Minor Projects PA 5.A.6

Second Choice:

Minor Projects PA 5.A.7

Third Choice:

Minor Projects PA 5.A.8

Built Environment

Response:

MoDOT has determined that the project is covered by Section V, Items 6, 7, 8, and 9 of the Programmatic Agreement Among the Federal Highway Administration, the Missouri Highway and Transportation Commission, the Advisory Council on Historic Preservation, and the Missouri State Historic Preservation Office for Minor Highway Projects.

Reviewer:

Althea Wunderler-Selby

Review completed for Built Environment

Archaeological

Response:

Disturbed (road construction, utilities, and drainages); no previously recorded sites or surveys. Shallow A-horizon soils.

Reviewer:

Geordon Taylor

Review completed for Archaeology

Environmental

Response:

3.20.25 - MoDOT has determined that the project is covered by Section V, Items 6, 7, 8, and 9 of the Programmatic Agreement Among the Federal Highway Administration, the Missouri Highway and Transportation Commission, the Advisory Council on Historic Preservation, and the Missouri State Historic Preservation Office for Minor Highway Projects. The project will result in No Historic Properties Affected and no additional Section 106 consultation is required at this time. 3.7.25 - Plans have been downloaded and are under review. 11.13.24 - Additional project detail is needed to determine whether a cultural resources survey is required.

LPA Action:

3.20.25 - No action is needed at this time. MoDOT will upload a PA form in the next two weeks and clear this section at that time. Be advised that if changes are made to the project (including but not limited to the addition of new right of way or easements, or the changing of the scope) the project will need to be reevaluated and additional clearances may be required. 11.13.24 - Please provide project plan sheets showing the limits of construction and any proposed right-of-way and/or easements.

Attachments:

PA\_Form\_2025-10-00093.pdf

Adverse Effect or Conditional No Adverse Effect

Based on the review of the project location and description noted above, there are no identified historic 4(f) resources affected that would preclude the setting of an A-date.

Checked by:

Geordon Taylor

on

04/03/2025

NA

Approved on:

Cultural Resources Impact Submitted - Mark submitted when this review is ready to be sent to district staff.

Last Updated: Geordon Taylor - 4/3/2025 9:33:28 AM

Public Land Impact (Section 4f/6f) Status: N/A

Status Information:  N/A  Pending  Cleared Clearance Date:

Environmental Response: According to Google Earth imagery, the Land and Water Conservation Fund online mapper, the All Trails website, and MoDNR Park and Site Status Viewer, there are no Section 4(f) or Section 6(f) resources in the vicinity of the project area. The project will not result in a use to any Section 4(f) properties, nor will it result in a conversion of any Section 6(f) lands.

LPA Action:

Attachments:

Based on the review of the project location and description noted above, there are no identified 4(f) or 6(f) resources affected that would preclude the setting of an A-date.  
Checked by: Aaron Stolte on 11/22/2024

Public Land Impact Submitted - Mark submitted when this review is ready to be sent to district staff.  
Last Updated: Aaron Stolte - 11/22/2024 12:44:18 PM

Other Status: N/A

Status Information:  N/A  Pending  Cleared Clearance Date:

Environmental Response: There are no WRP easements in the vicinity of the project. There are no airports within 4 miles of the project site.

LPA Action:

Attachments:

Other Screening Submitted - Mark submitted when this review is ready to be sent to district staff.  
Last Updated: Aaron Stolte - 11/22/2024 12:44:24 PM

NEPA Classification Status: Cleared

NEPA Right-Of-Way Permission: Not Applicable as determined or approved by: KYLE.GRAYSON@MODOT.MO.GOV  
NEPA Approval/Proceed to A-date Request: 04/04/2025 Re-evaluation Date:  
NEPA Classification: PCE  
This project qualifies for the programmatic categorical exclusion under Item#: 3 All Environmental Issues Cleared: 08/15/2025  
Commitments and/or Comments to Sponsor: UPDATE 08/15/25: If there are any changes in the scope of the project, MoDOT's Environmental section should review those changes. The sponsor is ultimately responsible for complying with all applicable state and federal laws. PCE approved for A-Date request ON 4/4/25 and for All Environmental Issues Cleared as of 08/15/25. THE LPA/CONSULTANT SHOULD REVIEW ALL SECTIONS ABOVE INCLUDING THOSE MARKED AS CLEARED/GREEN. UPDATE: If there are any changes in the scope of the project, MoDOT's Environmental section should review those changes. The sponsor is ultimately responsible for complying with all applicable state and federal laws. PCE approved for A-Date request as of 4/4/2025. All environmental issues cleared date will be provided once all sections are cleared. THE LPA/CONSULTANT SHOULD REVIEW ALL SECTIONS ABOVE INCLUDING THOSE MARKED AS CLEARED/GREEN. INITIAL: A Programmatic Categorical Exclusion (PCE) NEPA classification is anticipated for this proposed project but must be confirmed following resolution of pending items herein. The NEPA approval date will be given once the Cultural Resources, Threatened & Endangered Species, and Public Lands sections are cleared. THE LPA/CONSULTANT SHOULD REVIEW ALL SECTIONS ABOVE INCLUDING THOSE MARKED AS CLEARED/GREEN. Please note the following points of contact for the environmental review: -For Farmland, Socioeconomic, Noise, and Public Lands: Holly Cantrell, holly.cantrell@modot.mo.gov, 615-649-7391 -For Floodplain/Floodway, Land/Stormwater, FEMA/SEMA, T/E, Migratory Birds, Wetlands, and HazMat: Cassie Baumgartner, cassie.baumgartner@modot.mo.gov, 615-760-0185; and/or Aaron Stolte, aaron.stolte@modot.mo.gov, 612-326-9510 -For Cultural Resources: Archaeology: Geordon Taylor, geordon.taylor@modot.mo.gov, 918-895-6596 Historic Architecture: Kory Van Hemert, kory.vanhemert@modot.mo.gov, 918-907-3512

Attachments: [RE\\_Concurrence Request\\_2025-10-00093\\_CD\\_9901313\\_Carel Rd\\_Henwick Ln\\_COLE\\_MoDOT Concurrence.eml](#)

Last Submitted: 08/15/2025 by Holly Cantrell





## Missouri Department of Conservation

Missouri Department of Conservation's Mission is to protect and manage the forest, fish, and wildlife resources of the state and to facilitate and provide opportunities for all citizens to use, enjoy and learn about these resources.

### **Natural Heritage Review Level Three Report: Species Listed Under the Federal Endangered Species Act**

There are records of species listed under the Federal Endangered Species Act, and possibly also records for species listed Endangered by the state, or Missouri Species and/or Natural Communities of Conservation Concern within or near the the defined Project Area. Please contact the U.S. Fish and Wildlife Service and the Missouri Department of Conservation for further coordination.

**Foreword:** Thank you for accessing the Missouri Natural Heritage Review Website developed by the Missouri Department of Conservation with assistance from the U.S. Fish and Wildlife Service, the U.S. Army Corps of Engineers, Missouri Department of Transportation and NatureServe. The purpose of this report is to provide information to federal, state and local agencies, organizations, municipalities, corporations, and consultants regarding sensitive fish, wildlife, plants, natural communities, and habitats to assist in planning, designing, and permitting stages of projects.

#### **PROJECT INFORMATION**

**Project Name and ID Number:** St. Martins Carel and Henwick Sidewalk #15474

**User Project Number:** 16450

**Project Description:** Construction of sidewalk on W side of Carel Rd from Bus 50 W to Henwick Ln and S/E side of Henwick Ln from Carel Rd to Bus 50 W in St Martins; construction of curb and gutter at same locations where none exists; storm/drainage improvements and relocation of utilities as needed. Section 34 T45N R13W and Section 3 T44N R13W, 38.5981N, 92.3426W, Cole County.

**Project Type:** Transportation, Other

**Contact Person:** Stephen Simmons

**Contact Information:** [ssimmons@ess-inc.com](mailto:ssimmons@ess-inc.com) or 5736363303

**Disclaimer:** This NATURAL HERITAGE REVIEW REPORT identifies if a species or natural community tracked by the Natural Heritage Program is known to occur within or near the project area submitted, and shares recommendations to avoid or minimize project impacts to sensitive species or natural habitats. Incorporating information from the Natural Heritage Program into project plans is an important step in reducing impacts to Missouri's sensitive natural resources. If an occurrence record is present, or the proposed project might affect federally listed species, the user must contact the Department of Conservation or U.S. Fish and Wildlife Service for more information.

This Natural Heritage Review Report is not a site clearance letter for the project. Rather, it identifies public lands and records of sensitive resources located close to and/or potentially affected by the proposed project. If project plans or location change, this report may no longer be valid. Because land use conditions change and animals move, the existence of an occurrence record does not mean the species/habitat is still present. Therefore, reports include information about records near but not necessarily on the project site. Lack of an occurrence record does not mean that a sensitive species or natural community is not present on or near the project area. On-site verification is the responsibility of the project. However, the Natural Heritage Program is only one reference that should be used to evaluate potential adverse project impacts and additional information (e.g. wetland or soils maps, on-site inspections or surveys) should be considered. Reviewing current landscape and habitat information, and species' biological characteristics would additionally ensure that Missouri Species of Conservation Concern are appropriately identified and addressed in planning efforts.

**U.S. Fish and Wildlife Service – Endangered Species Act (ESA) Coordination:** Lack of a Natural Heritage Program occurrence record for federally listed species in your project area does not mean the species is not present, as the area may never have been surveyed. Presence of a Natural Heritage Program occurrence record does not mean the project will result in negative impacts. This report does not fulfill Endangered Species Act consultation with the U.S. Fish and Wildlife Service (USFWS) for listed species. Direct contact with the USFWS may be necessary to complete consultation and it is required for actions with a federal connection, such as federal funding or a federal permit; direct contact is also required if ESA concurrence is necessary. Visit [IPaC: Home \(fws.gov\)](https://www.fws.gov/ipac) to initiate USFWS Information for Planning and Conservation (IPaC) consultation. Contact the Columbia Missouri Ecological Field Services Office (573-234-2132, or by mail at 101 Park Deville Drive, Suite A, Columbia, MO 65203) for more information.

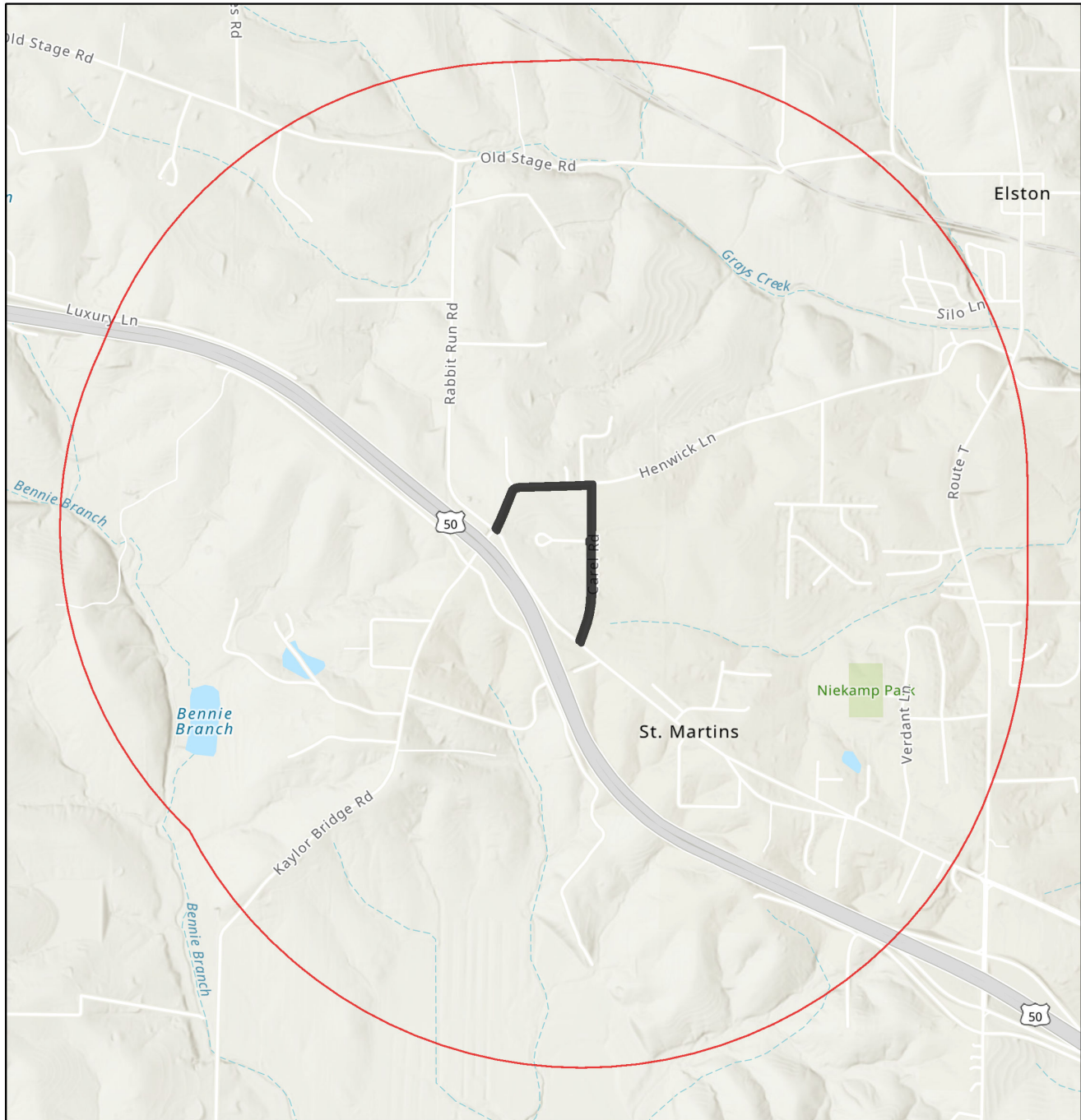

**Transportation Projects:** If the project involves the use of Federal Highway Administration transportation funds, these recommendations may not fulfill all contract requirements. Please contact the Missouri Department of Transportation at 573-526-4778 or visit [Home Page | Missouri Department of Transportation \(modot.org\)](https://www.modot.org) for additional information on recommendations.

# St. Martins Carel and Henwick Sidewalk



October 22, 2024

1:20,919

-  Buffered Project Boundary
-  Project Boundary

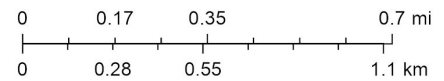

Missouri Dept. of Conservation, Missouri DNR, Esri, TomTom, Garmin, SafeGraph, GeoTechnologies, Inc, METI/NASA, USGS, EPA, NPS, US Census Bureau, USDA, USFWS, Esri, NASA, NGA, USGS, FEMA

## Species or Communities of Conservation Concern within the Area:

There are records of species listed under the Federal Endangered Species Act, and possibly also records for species listed Endangered by the state, or Missouri Species and/or Natural Communities of Conservation Concern within or near the defined Project Area. Please contact the U.S. Fish and Wildlife Service and the Missouri Department of Conservation for further coordination.

Email (preferred): [NaturalHeritageReview@mdc.mo.gov](mailto:NaturalHeritageReview@mdc.mo.gov)  
MDC Natural Heritage Review  
Science Branch  
P.O. Box 180  
Jefferson City, MO  
65102-0180  
Phone: 573-522-4115 ext. 3182

U.S. Fish and Wildlife Service  
Ecological Service  
101 Park Deville Drive  
Suite A  
Columbia, MO  
65203-0007  
Phone: 573-234-2132

## Other Special Search Results:

No results have been identified for this project location.

## Project Type Recommendations:

**Transportation -Other:** projects typically change the plants and animals that live on the right-of-way or in the vicinity. Minimize erosion and sedimentation/runoff to nearby streams and lakes by carefully adhering to any Clean Water Act permit conditions; and include design elements to manage stormwater so that present water discharge rates from the site to streams during heavy rain events are not increased. Revegetation of disturbed areas is recommended to minimize erosion, as is restoration with native plant species compatible with the local landscape and wildlife needs. Annuals like ryegrass may be combined with native perennials for quicker green-up. Avoid aggressive exotic perennials such as crown vetch and sericea lespedeza.

Maintenance of ground cover in utility corridors can have significant implications for sensitive resources. Native plant species typically require low maintenance over the long term, and provide more benefits to native wildlife. Use silt fences and/or vegetative filter strips to buffer streams and drainages, and monitor those after rain events and until a well-rooted ground cover is reestablished. Please see [Best Management Practices for Construction and Development Projects Affecting Missouri Rivers and Streams \(mo.gov\)](#) for projects near waterways.

## Project Location and/or Species Recommendations:

**Endangered Species Act Coordination - If this project has the potential to alter habitat (e.g. tree removal, projects in karst habitat) or cause direct mortality of bats, please coordinate directly with U.S. Fish and Wildlife Service (Ecological Services, 101 Park Deville Drive, Suite A, Columbia, Missouri 65203-0007; Phone 573-234-2132 Ext. 100 for Ecological Services) for further coordination under the Endangered Species Act. Indiana bats (*Myotis sodalis*, federal- and state-listed endangered) and Northern long-eared bats (*Myotis septentrionalis*, federal-listed threatened) may occur near the project area. Both of these species of bats hibernate during winter months in caves and mines. During the summer months, they roost and raise young under the bark of trees in wooded areas, often riparian forests and upland forests near perennial streams. During project activities, avoid degrading stream quality and where possible leave snags standing and preserve mature forest canopy. Do not enter caves known to harbor Indiana bats or Northern long-eared bats, especially from September to April.**

**Karst:** This county has known karst geologic features (e.g., caves, springs, and sinkholes, all characterized by subterranean water movement). Few karst features are recorded in Natural Heritage records, and ones not noted here may be encountered at the project site or affected by the project. Cave fauna (many of which are Species of Conservation Concern) are influenced by changes to water quality; please check your project site for any karst features and make every effort to protect groundwater in the project area. Additional information and specific recommendations are available at [Management Recommendations for Construction and Development Projects Affecting Missouri Karst Habitat \(mo.gov\)](#).

**Invasive exotic species** are a significant issue for fish, wildlife and agriculture in Missouri. Seeds, eggs, and larvae may be moved to new sites on boats or construction equipment. Please inspect and clean equipment thoroughly before moving between project sites. See [Managing Invasive Species in Your Community | Missouri Department of Conservation \(mo.gov\)](#) for more information.

- Remove any mud, soil, trash, plants or animals from equipment before leaving any water body or work area.
- Drain water from boats and machinery that have operated in water, checking motor cavities, live-well, bilge and transom wells, tracks, buckets, and any other water reservoirs.
- When possible, wash and rinse equipment thoroughly with hard spray or HOT water (>140° F, typically available at do-it-yourself car wash sites), and dry in the hot sun before using again.

**Streams and Wetlands – Clean Water Act Permits:** Streams and wetlands in the project area should be protected from activities that degrade habitat conditions. For example, soil erosion, water pollution, placement of fill, dredging, in-stream activities, and riparian corridor removal, can modify or diminish aquatic habitats. Streams and wetlands may be protected under the Clean Water Act and require a permit for any activities that result in fill or other modifications to the site. Conditions provided within the U.S. Army Corps of Engineers (USACE) Clean Water Act Section 404 permit ([Kansas City District Regulatory Branch \(army.mil\)](#)) and the Missouri Department of Natural Resources (DNR) issued Clean Water Act Section 401 Water Quality Certification ([Section 401 Water Quality Certification | Missouri Department of Natural Resources \(mo.gov\)](#)), if required, should help minimize impacts to the aquatic organisms and aquatic habitat within the area. Depending on your project type, additional permits may be required by the Missouri Department of Natural Resources, such as permits for stormwater, wastewater treatment facilities, and confined animal feeding operations. Visit [Wastewater Permits | Missouri Department of Natural Resources \(mo.gov\)](#) for more information on DNR permits. Visit both the USACE and DNR for more information on Clean Water Act permitting.

**For further coordination with the Missouri Department of Conservation and the U.S. Fish and Wildlife Services, please see the contact information below:**

Email (preferred): [NaturalHeritageReview@mdc.mo.gov](mailto:NaturalHeritageReview@mdc.mo.gov)  
MDC Natural Heritage Review  
Science Branch  
P.O. Box 180  
Jefferson City, MO  
65102-0180  
Phone: 573-522-4115 ext. 3182

U.S. Fish and Wildlife Service  
Ecological Service  
101 Park Deville Drive  
Suite A  
Columbia, MO  
65203-0007  
Phone: 573-234-2132

### **Miscellaneous Information**

FEDERAL Concerns are species/habitats protected under the Federal Endangered Species Act and that have been known near enough to the project site to warrant consideration. For these, project managers must contact the U.S. Fish and Wildlife Service Ecological Services (101 Park Deville Drive Suite A, Columbia, Missouri 65203-0007; Phone 573-234-2132; Fax 573-234-2181) for consultation.

STATE Concerns are species/habitats known to exist near enough to the project site to warrant concern and that are protected under the Wildlife Code of Missouri (RSMo 3 CSR 1 0). "State Endangered Status" is determined by the Missouri Conservation Commission under constitutional authority, with requirements expressed in the Missouri Wildlife Code, rule 3CSR 1 0-4.111. Species tracked by the Natural Heritage Program have a "State Rank" which is a numeric rank of relative rarity. Species tracked by this program and all native Missouri wildlife are protected under rule 3CSR 10-4.110 General Provisions of the Wildlife Code.

See [Missouri Species and Communities of Conservation Concern Checklist \(mo.gov\)](#) for a complete list of species and communities of conservation concern. Detailed information about the animals and some plants mentioned may be accessed at [Mofwis Search Results](#). Please contact the Missouri Department of Conservation to request printed copies of any materials linked in this document.

## Stephen Simmons

---

**From:** Natural Heritage Review <NaturalHeritageReview@mdc.mo.gov>  
**Sent:** Thursday, January 2, 2025 12:06 PM  
**To:** ssimmons@ess-inc.com  
**Subject:** NHRR for Cole County project 15474

Hello,

At this time, we have no additional recommendations regarding your Cole County project (St. Martins Carel and Henwick Sidewalk). Please refer to your automated report for ways to minimize impacts to Missouri's sensitive natural resources. Please let me know if you have any questions.

Thank you for using the Natural Heritage Review Program,

*Dillon Freiburger*

Environmental Review Analyst  
Missouri Department of Conservation  
Dillon.Freiburger@mdc.mo.gov





# United States Department of the Interior



FISH AND WILDLIFE SERVICE  
Missouri Ecological Services Field Office  
101 Park Deville Drive  
Suite A  
Columbia, MO 65203-0057  
Phone: (573) 234-2132 Fax: (573) 234-2181

In Reply Refer To:

10/23/2024 13:44:25 UTC

Project Code: 2025-0009733

Project Name: St. Martins Carel and Henwick Sidewalk

Subject: List of threatened and endangered species that may occur in your proposed project location or may be affected by your proposed project

To Whom It May Concern:

The enclosed species list identifies threatened, endangered, proposed and candidate species, as well as proposed and final designated critical habitat, that may occur within the boundary of your proposed project and/or may be affected by your proposed project. The species list fulfills the requirements of the U.S. Fish and Wildlife Service (Service) under section 7(c) of the Endangered Species Act (Act) of 1973, as amended (16 U.S.C. 1531 *et seq.*).

### **Threatened and Endangered Species**

The enclosed species list identifies threatened, endangered, proposed and candidate species, as well as proposed and final designated critical habitat, that may occur within the boundary of your proposed project and may be affected by your proposed project. The species list fulfills the requirement for obtaining a Technical Assistance Letter from the U.S. Fish and Wildlife Service (Service) under section 7(c) of the Endangered Species Act (Act) of 1973, as amended (16 U.S.C. 1531 *et seq.*).

New information based on updated surveys, changes in the abundance and distribution of species, changed habitat conditions, or other factors could change this list. **Note that under 50 CFR 402.12(e) of the regulations implementing section 7 of the Act, the accuracy of this species list should be verified after 90 days.** The Service recommends that verification be completed by visiting the IPaC website at regular intervals during project planning and implementation for updates to species lists and information. An updated list may be requested through the IPaC system by completing the same process used to receive the enclosed list.

### **Consultation Technical Assistance**

Refer to the Midwest Region [S7 Technical Assistance](#) website for step-by-step instructions for making species determinations and for specific guidance on the following types of projects:



projects in developed areas, HUD, pipelines, buried utilities, telecommunications, and requests for a Conditional Letter of Map Revision (CLOMR) from FEMA.

### Federally Listed Bat Species

Indiana bats, gray bats, and northern long-eared bats occur throughout Missouri and the information below may help in determining if your project may affect these species.

*Gray bats* - Gray bats roost in caves or mines year-round and use water features and forested riparian corridors for foraging and travel. If your project will impact caves, mines, associated riparian areas, or will involve tree removal around these features – particularly within stream corridors, riparian areas, or associated upland woodlots –gray bats could be affected.

*Indiana and northern long-eared bats* - These species hibernate in caves or mines only during the winter. In Missouri the hibernation season is considered to be November 1 to March 31. During the active season in Missouri (April 1 to October 31) they roost in forest and woodland habitats. Suitable summer habitat for Indiana bats and northern long-eared bats consists of a wide variety of forested/wooded habitats where they roost, forage, and travel and may also include some adjacent and interspersed non-forested habitats such as emergent wetlands and adjacent edges of agricultural fields, old fields and pastures. This includes forests and woodlots containing potential roosts (i.e., live trees and/or snags  $\geq 5$  inches diameter at breast height (dbh) for Indiana bat, and  $\geq 3$  inches dbh for northern long-eared bat, that have exfoliating bark, cracks, crevices, and/or hollows), as well as linear features such as fencerows, riparian forests, and other wooded corridors. These wooded areas may be dense or loose aggregates of trees with variable amounts of canopy closure. Tree species often include, but are not limited to, shellbark or shagbark hickory, white oak, cottonwood, and maple. Individual trees may be considered suitable habitat when they exhibit the characteristics of a potential roost tree and are located within 1,000 feet (305 meters) of other forested/wooded habitat. Northern long-eared bats have also been observed roosting in human-made structures, such as buildings, barns, bridges, and bat houses; therefore, these structures should also be considered potential summer habitat and evaluated for use by bats. If your project will impact caves or mines or will involve clearing forest or woodland habitat containing suitable roosting habitat, Indiana bats or northern long-eared bats could be affected.

Examples of unsuitable habitat include:

- Individual trees that are greater than 1,000 feet from forested or wooded areas;
- Trees found in highly-developed urban areas (e.g., street trees, downtown areas);
- A pure stand of less than 3-inch dbh trees that are not mixed with larger trees; and
- A stand of eastern red cedar shrubby vegetation with no potential roost trees.

### Using the IPaC Official Species List to Make No Effect and May Affect Determinations for Listed Species

1. If IPaC returns a result of “There are no listed species found within the vicinity of the project,” then project proponents can conclude the proposed activities will have **no effect** on any federally listed species under Service jurisdiction. Concurrence from the Service is not required for **No Effect** determinations. No further consultation or coordination is required. Attach this letter to the dated IPaC species list report for your records. An example ["No Effect" document](#) also can be found on the S7 Technical Assistance website.

2. If IPaC returns one or more federally listed, proposed, or candidate species as potentially present in the action area of the proposed project – other than bats (see #3 below) – then project proponents can conclude the proposed activities **may affect** those species. For assistance in determining if suitable habitat for listed, candidate, or proposed species occurs within your project area or if species may be affected by project activities, you can obtain [Life History Information for Listed and Candidate Species](#) through the Species website.
3. If IPaC returns a result that one or more federally listed bat species (Indiana bat, northern long-eared bat, or gray bat) are potentially present in the action area of the proposed project, project proponents can conclude the proposed activities **may affect** these bat species **IF** one or more of the following activities are proposed:
  - a. Clearing or disturbing suitable roosting habitat, as defined above, at any time of year;
  - b. Any activity in or near the entrance to a cave or mine;
  - c. Mining, deep excavation, or underground work within 0.25 miles of a cave or mine;
  - d. Construction of one or more wind turbines; or
  - e. Demolition or reconstruction of human-made structures that are known to be used by bats based on observations of roosting bats, bats emerging at dusk, or guano deposits or stains.

If none of the above activities are proposed, project proponents can conclude the proposed activities will have **no effect** on listed bat species. Concurrence from the Service is not required for **No Effect** determinations. No further consultation or coordination is required. Attach this letter to the dated IPaC species list report for your records. An example "[No Effect](#)" document also can be found on the S7 Technical Assistance website.

If any of the above activities are proposed in areas where one or more bat species may be present, project proponents can conclude the proposed activities **may affect** one or more bat species. We recommend coordinating with the Service as early as possible during project planning. If your project will involve removal of over 5 acres of suitable forest or woodland habitat, we recommend you complete a Summer Habitat Assessment prior to contacting our office to expedite the consultation process. The Summer Habitat Assessment Form is available in Appendix A of the most recent version of the [Range-wide Indiana Bat Summer Survey Guidelines](#).

### **Other Trust Resources and Activities**

*Bald and Golden Eagles* - Although the bald eagle has been removed from the endangered species list, this species and the golden eagle are protected by the Bald and Golden Eagle Act and the Migratory Bird Treaty Act. Should bald or golden eagles occur within or near the project area please contact our office for further coordination. For communication and wind energy projects, please refer to additional guidelines below.

*Migratory Birds* - The Migratory Bird Treaty Act (MBTA) prohibits the taking, killing, possession, transportation, and importation of migratory birds, their eggs, parts, and nests, except when specifically authorized by the Service. The Service has the responsibility under the MBTA

to proactively prevent the mortality of migratory birds whenever possible and we encourage implementation of recommendations that minimize potential impacts to migratory birds. Such measures include clearing forested habitat outside the nesting season (generally March 1 to August 31) or conducting nest surveys prior to clearing to avoid injury to eggs or nestlings.

*Communication Towers* - Construction of new communications towers (including radio, television, cellular, and microwave) creates a potentially significant impact on migratory birds, especially some 350 species of night-migrating birds. However, the Service has developed [voluntary guidelines for minimizing impacts](#).

*Transmission Lines* - Migratory birds, especially large species with long wingspans, heavy bodies, and poor maneuverability can also collide with power lines. In addition, mortality can occur when birds, particularly hawks, eagles, kites, falcons, and owls, attempt to perch on uninsulated or unguarded power poles. To minimize these risks, please refer to [guidelines](#) developed by the Avian Power Line Interaction Committee and the Service. Implementation of these measures is especially important along sections of lines adjacent to wetlands or other areas that support large numbers of raptors and migratory birds.

*Wind Energy* - To minimize impacts to migratory birds and bats, wind energy projects should follow the Service's [Wind Energy Guidelines](#). In addition, please refer to the Service's [Eagle Conservation Plan Guidance](#), which provides guidance for conserving bald and golden eagles in the course of siting, constructing, and operating wind energy facilities.

#### **Next Steps**

Should you determine that project activities **may affect** any federally listed species or trust resources described herein, please contact our office for further coordination. Letters with requests for consultation or correspondence about your project should include the Consultation Tracking Number in the header. Electronic submission is preferred.

If you have not already done so, please contact the Missouri Department of Conservation (Policy Coordination, P. O. Box 180, Jefferson City, MO 65102) for information concerning Missouri Natural Communities and Species of Conservation Concern.

We appreciate your concern for threatened and endangered species. Please feel free to contact our office with questions or for additional information.

John Weber

Attachment(s):

- Official Species List

## OFFICIAL SPECIES LIST

This list is provided pursuant to Section 7 of the Endangered Species Act, and fulfills the requirement for Federal agencies to "request of the Secretary of the Interior information whether any species which is listed or proposed to be listed may be present in the area of a proposed action".

This species list is provided by:

**Missouri Ecological Services Field Office**

101 Park Deville Drive

Suite A

Columbia, MO 65203-0057

(573) 234-2132

## PROJECT SUMMARY

Project Code: 2025-0009733  
Project Name: St. Martins Carel and Henwick Sidewalk  
Project Type: Federal Grant / Loan Related  
Project Description: Construction of sidewalk on W side of Carel Rd from Bus 50 W to Henwick Ln and S/E side of Henwick Ln from Carel Rd to Bus 50 W in St Martins; construction of curb and gutter at same locations where none exists; storm/drainage improvements and relocation of utilities as needed. Section 34 T45N R13W and Section 3 T44N R13W, 38.5981N, 92.3426W, Cole County.

Project Location:

The approximate location of the project can be viewed in Google Maps: <https://www.google.com/maps/@38.60079265,-92.34210795659088,14z>

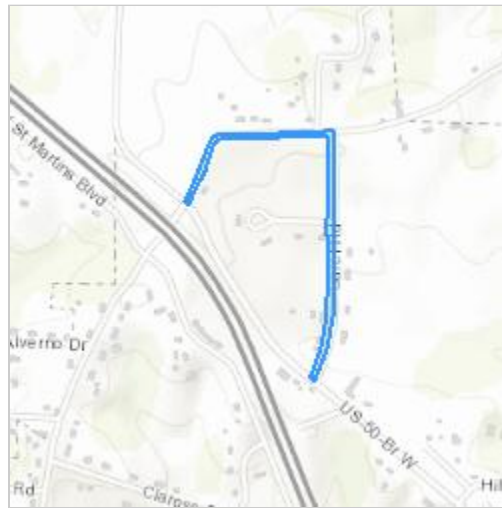

Counties: Cole County, Missouri

## ENDANGERED SPECIES ACT SPECIES

There is a total of 6 threatened, endangered, or candidate species on this species list.

Species on this list should be considered in an effects analysis for your project and could include species that exist in another geographic area. For example, certain fish may appear on the species list because a project could affect downstream species.

IPaC does not display listed species or critical habitats under the sole jurisdiction of NOAA Fisheries<sup>1</sup>, as USFWS does not have the authority to speak on behalf of NOAA and the Department of Commerce.

See the "Critical habitats" section below for those critical habitats that lie wholly or partially within your project area under this office's jurisdiction. Please contact the designated FWS office if you have questions.

- 
1. [NOAA Fisheries](#), also known as the National Marine Fisheries Service (NMFS), is an office of the National Oceanic and Atmospheric Administration within the Department of Commerce.

**MAMMALS**

NAME	STATUS
Gray Bat <i>Myotis grisescens</i> No critical habitat has been designated for this species. Species profile: <a href="https://ecos.fws.gov/ecp/species/6329">https://ecos.fws.gov/ecp/species/6329</a>	Endangered
Indiana Bat <i>Myotis sodalis</i> There is <b>final</b> critical habitat for this species. Your location does not overlap the critical habitat. Species profile: <a href="https://ecos.fws.gov/ecp/species/5949">https://ecos.fws.gov/ecp/species/5949</a> General project design guidelines: <a href="https://ipac.ecosphere.fws.gov/project/MVPL25V5IVCDBF6KLQ2VO3XPLU/documents/generated/7280.pdf">https://ipac.ecosphere.fws.gov/project/MVPL25V5IVCDBF6KLQ2VO3XPLU/documents/generated/7280.pdf</a>	Endangered
Northern Long-eared Bat <i>Myotis septentrionalis</i> No critical habitat has been designated for this species. Species profile: <a href="https://ecos.fws.gov/ecp/species/9045">https://ecos.fws.gov/ecp/species/9045</a> General project design guidelines: <a href="https://ipac.ecosphere.fws.gov/project/MVPL25V5IVCDBF6KLQ2VO3XPLU/documents/generated/7280.pdf">https://ipac.ecosphere.fws.gov/project/MVPL25V5IVCDBF6KLQ2VO3XPLU/documents/generated/7280.pdf</a>	Endangered
Tricolored Bat <i>Perimyotis subflavus</i> No critical habitat has been designated for this species. Species profile: <a href="https://ecos.fws.gov/ecp/species/10515">https://ecos.fws.gov/ecp/species/10515</a>	Proposed Endangered

**INSECTS**

NAME	STATUS
Monarch Butterfly <i>Danaus plexippus</i> No critical habitat has been designated for this species. Species profile: <a href="https://ecos.fws.gov/ecp/species/9743">https://ecos.fws.gov/ecp/species/9743</a>	Candidate
Western Regal Fritillary <i>Argynnis idalia occidentalis</i> No critical habitat has been designated for this species. Species profile: <a href="https://ecos.fws.gov/ecp/species/12017">https://ecos.fws.gov/ecp/species/12017</a>	Proposed Threatened

**CRITICAL HABITATS**

THERE ARE NO CRITICAL HABITATS WITHIN YOUR PROJECT AREA UNDER THIS OFFICE'S JURISDICTION.

YOU ARE STILL REQUIRED TO DETERMINE IF YOUR PROJECT(S) MAY HAVE EFFECTS ON ALL ABOVE LISTED SPECIES.

## **IPAC USER CONTACT INFORMATION**

Agency: St. Martins city  
Name: Stephen Simmons  
Address: 802 El Dorado Dr  
City: Jefferson City  
State: MO  
Zip: 65101  
Email: ssimmons@ess-inc.com  
Phone: 5736363303

## **LEAD AGENCY CONTACT INFORMATION**

Lead Agency: Missouri Department of Transportation

You have indicated that your project falls under or receives funding through the following special project authorities:

- FAST-41





# ADA CHECKLIST

Revised December 22, 2022

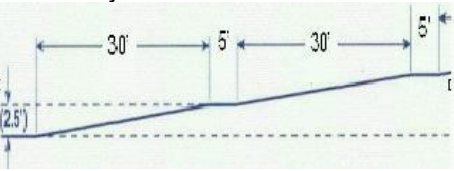

Job No. \_\_\_\_\_ Route \_\_\_\_\_ County \_\_\_\_\_ Location \_\_\_\_\_

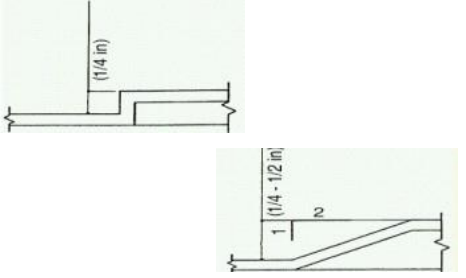
<b>Pedestrian Access Route (PROWAG R204)</b>				
<b>Figures/Examples</b>	<b>Requirements <sup>1</sup></b>	<b>YES</b>	<b>NO</b>	<b>NA</b>
<p><b>Sidewalk Width</b></p> 	<ul style="list-style-type: none"> <li>The minimum continuous and unobstructed clear width of a pedestrian access route shall be 4.0 feet, exclusive of the width of the curb.</li> <li>The continuous clear width of pedestrian access routes for medians and pedestrian refuge islands must be 5 feet minimum in order to allow for passing space.</li> <li>MoDOT Sidewalks shall be 5 feet wide minimum. <sup>2</sup></li> <li>MoDOT Sidewalks located within 2 feet of the back of curb are to be constructed 6 feet wide minimum and constructed adjacent to the back of the curb. <sup>2</sup></li> <li>Exception: an unaltered, existing sidewalk shall be 3 feet wide minimum and shall provide 5 foot x 5 foot passing spaces at intervals of 200 feet maximum. <sup>2</sup></li> <li>Detectable warning surfaces shall be provided, where a curb ramp, landing, or blended transition connects to a street. Where commercial driveways are provided with traffic control devices or otherwise are permitted to operate like public streets, detectable warnings should be provided at the junction between the pedestrian route and the street.</li> <li>Gratings, access covers, and other appurtenances shall not be located on curb ramps, landings, blended transitions, and gutters within the pedestrian access route.</li> <li>Grade breaks shall not be permitted on the surface of curb ramps, blended transitions, landings, and gutter areas within the pedestrian access route. Surface slopes that meet at grade breaks shall be flush.</li> </ul>			
<p><b>Passing Spaces</b></p>	<ul style="list-style-type: none"> <li>Walkways in pedestrian access routes that are less than 5 feet in clear width shall provide passing spaces at intervals of 200 feet maximum.</li> <li>Pedestrian access routes at passing spaces shall be 5 feet wide for a distance of 5 feet.</li> </ul>			
<p><b>Sidewalk Running Slope</b> The grade that is parallel to the direction of travel, expressed as a ratio of rise to run or as a percent.</p>	<ul style="list-style-type: none"> <li>The running slope of a pedestrian access route shall be 5 percent maximum.</li> </ul> <p><b><u>Roadway Grade Exception:</u></b> Where pedestrian access routes are contained within a street or highway right-of-way, the grade of the pedestrian access route is permitted to equal the general grade established for the adjacent street or highway.</p> <ul style="list-style-type: none"> <li>Running Slopes shall be measured using a calibrated 2 foot long digital level.</li> </ul>			

Figures/Examples	Requirements <sup>1</sup>	YES	NO	NA
<p><b>Sidewalk Cross Slope</b>            The grade that is perpendicular to the direction of accessible pedestrian travel, measured perpendicular to the curb line or edge of the street or highway, or measured perpendicular to the running grade.</p>	<ul style="list-style-type: none"> <li>• The cross slope of the walkway of a pedestrian access route shall be 2 percent maximum. (Roadway Grade Exception may be considered)</li> <li>• 2010 ADA/ABA allows for cross slopes of up to ¼ inch per foot (2.08 percent).</li> <li>• In either case, a cross slope measurement of 2.1 percent or greater is not ADA compliant.</li> <li>• Cross Slopes shall be measured using a calibrated 2 foot long digital level.</li> </ul>			
<p><b>Sidewalk Ramps</b></p> <p>For example, a ramp segment with the maximum allowed running slope of 8.33% would require 5' x 5' landing after every 30' of run.</p> 	<ul style="list-style-type: none"> <li>• A sidewalk segment (not contained within a street or highway border) with a running grade in excess of 5 percent but less than 8.33 percent is by definition a sidewalk ramp.</li> <li>• The clear width of landings, blended transitions, and curb ramps, excluding flares, shall be 4.0 feet minimum.</li> <li>• Cross slope of ramp runs shall be 2 percent maximum.</li> <li>• The rise for any ramp run shall be 30 inches maximum.</li> <li>• Ramps shall have landings at the top and the bottom of each ramp run.</li> <li>• Ramp runs with a rise greater than 6 inches shall have handrails.</li> <li>• Handrails shall be provided on both sides of stairs and ramps.</li> <li>• Edge protection shall be provided on each side of ramp runs.</li> <li>• Detectable warning surfaces shall be provided, where a curb ramp, landing, or blended transition connects to a street.</li> <li>• Gratings, access covers, and other appurtenances shall not be located on ramps, landings, blended transitions, and gutters within the pedestrian access route.</li> <li>• Grade breaks shall not be permitted on the surface of ramps, blended transitions, landings, and gutter areas within the pedestrian access route. Surface slopes that meet at grade breaks shall be flush.</li> </ul>			

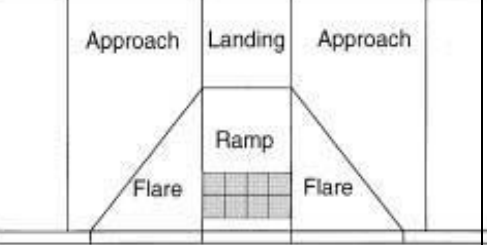
Figures/Examples	Requirements <sup>1</sup>	YES	NO	NA
<p>Vertical Alignment</p>	<ul style="list-style-type: none"> <li>Vertical alignment shall be planar within curb ramp runs, blended transitions, landings, and gutter areas within the pedestrian access route, and within clear spaces required for accessible pedestrian signals, street furniture, and operable parts.</li> <li>Grade breaks shall not be permitted on the surface of curb ramps, blended transitions, landings, and gutter areas within the pedestrian access route.</li> <li>Grade breaks shall be flush.</li> <li>Running Slopes and Cross Slopes shall be measured using a calibrated 2 foot long digital level.</li> <li>Where the pedestrian access route crosses rail tracks at grade, the surface of the pedestrian access route shall be level and flush with the top of the rail at the outer edges of the rail. The surface between the rails shall be aligned with the top of the rail.</li> </ul>			
<p>Changes in Level</p>  	<ul style="list-style-type: none"> <li>Changes in level at grade breaks shall be flush.</li> <li>Changes in level of ¼ inch high maximum shall be permitted to be vertical.</li> <li>Changes in level between ¼ inch high maximum and ½ inch high maximum shall be beveled with a slope not steeper than 1v:2h.</li> <li>The bevel shall be applied across the entire level change.</li> <li>Changes in level greater than ½ inch high shall be ramp grade or flatter, a slope of 8.33 percent or less.</li> </ul>			

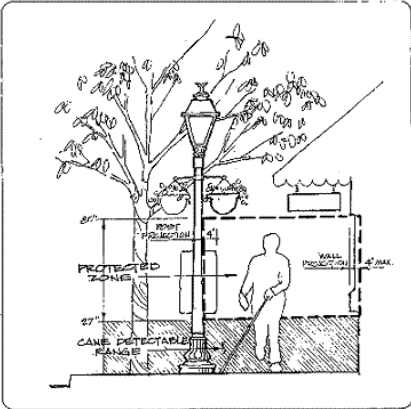
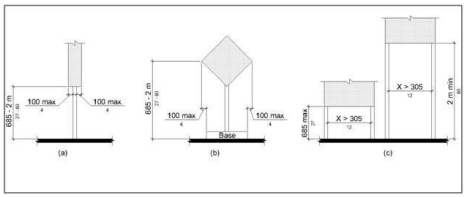
Figures/Examples	Requirements <sup>1</sup>	YES	NO	NA
<p><b>Landing</b> A required level space required at both ends of a ramp. An area 5' x 5' with no slope greater than 2 percent. This space can be used as a place to rest, turn or pass another user.</p> <p>Landings that are contained within a street or highway border are permitted to use the Roadway Grade Exception for running slopes or cross slopes in the direction of the roadway travel being matched.</p>	<ul style="list-style-type: none"> <li>The landing clear width shall be at least as wide as the widest ramp run leading to the landing.</li> <li>The clear width of landings, blended transitions, and curb ramps, excluding flares, shall be 4 feet minimum.</li> <li>The landing clear length shall be 5 feet long minimum.</li> <li>Landing slopes shall be 2 percent maximum.</li> <li>Changes in level at grade breaks shall be flush.</li> <li>Detectable warning surfaces shall be provided, where a curb ramp, landing, or blended transition connects to a street. Detectable warning shall be located on the landing or blended transition at the back of curb.</li> <li>Gratings, access covers, and other appurtenances shall not be located on curb ramps, landings, blended transitions, and gutters within the pedestrian access route.</li> <li>Grade breaks shall not be permitted on the surface of curb ramps, blended transitions, landings, and gutter areas within the pedestrian access route. Surface slopes that meet at grade breaks shall be flush.</li> </ul>			
 <p>The diagram illustrates a cross-section of a pedestrian access route. It shows a central 'Landing' area flanked by 'Approach' areas. A 'Ramp' leads up to the landing, and 'Flare' areas are shown on either side of the ramp. Below the landing and approach areas is a 'Gutter'.</p>	<p><b><u>Roadway Grade Exception:</u></b> The grade of pedestrian access routes within sidewalks is permitted to equal the general grade established for the adjacent street or highway. The cross slope of curb ramps, blended transitions, landings, and turning spaces at pedestrian street crossings without yield or stop control where vehicles can proceed through the intersection without slowing or stopping, and at midblock pedestrian street crossings are permitted to equal the street or highway grade.</p>			
	<ul style="list-style-type: none"> <li>Running Slopes and Cross Slopes shall be measured using a calibrated 2 foot long digital level.</li> </ul>			

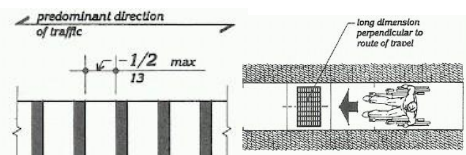
Figures/Examples	Requirements <sup>1</sup>	YES	NO	NA
 	<ul style="list-style-type: none"> <li>• Protruding objects on sidewalks and other pedestrian circulation paths shall not reduce the clear width required for pedestrian accessible routes.</li> <li>• Objects with leading edges more than 27 inches and not more than 80 inches above the finish floor or ground shall protrude 4 inches maximum horizontally into the circulation path.</li> <li>• Free-standing objects mounted on posts or pylons shall overhang circulation paths 4 inches maximum measured horizontally from the post or pylon base when located 27 inches minimum and 80 inches maximum above the finish floor or ground. The base dimension shall be 2.5 inches thick minimum. (2011 PROWAG R402.3)</li> <li>• Where a sign or other obstruction is mounted between posts or pylons and the clear distance between the posts or pylons is greater than 12 inches, the lowest edge of such sign or obstruction shall be 27 inches maximum or 80 inches minimum above the finish floor or ground.</li> <li>• Vertical clearance shall be 80 inches high minimum. Guardrails or other barriers shall be provided where the vertical clearance is less than 80 inches high. The leading edge of such guardrail or barrier shall be located 27 inches maximum above the finish floor or ground.</li> <li>• Guardrails or other barriers shall be provided where the vertical clearance is less than 80 inches high. The leading edge of such guardrail or barrier shall be located 27 inches maximum above the finish surface or ground.</li> </ul>			
   <p data-bbox="357 1209 546 1242">Wrong Installation</p>	<ul style="list-style-type: none"> <li>• Openings in floor and ground surfaces shall not allow passage of a sphere more than 1/2 inch diameter. Elongated openings shall be placed so that the long dimension is perpendicular to the dominant direction of travel.</li> <li>• Gratings, access covers, and other appurtenances shall not be located on curb ramps, landings, blended transitions, and gutters within the pedestrian access route.</li> <li>• Lift holes for manhole/utility covers shall not have an opening greater than 1/2 inch. Plugging of holes greater than 1/2 inch with a material approved by the engineer is acceptable as long as it complies with the changes in level requirements.</li> </ul>			

**ENTRANCES (PROWAG R301)**

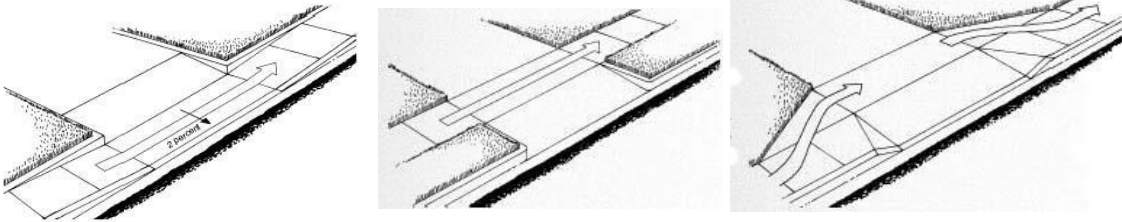
Figures/Examples	Requirements <sup>1</sup>	YES	NO	NA
	<ul style="list-style-type: none"> <li>The minimum continuous and unobstructed clear width of a pedestrian access route provided across commercial and residential entrances shall be 4 feet minimum.</li> <li>Cross slope shall be 2 percent maximum.</li> <li>Be cautious with the transition from the driveway to the roadway to avoid grade combinations that will cause vehicles to bottom out when driving over the transition. <sup>2</sup></li> </ul> 			

**EDGE PROTECTION (PROWAG R406.8)**

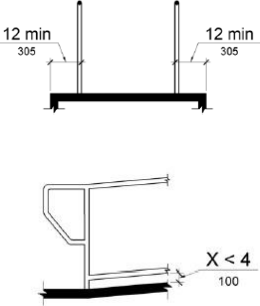
Figures/Examples	Requirements <sup>1</sup>	YES	NO	NA
	<ul style="list-style-type: none"> <li>Edge protection shall be provided on each side of ramp runs and at each side of ramp landings.</li> <li>A curb or barrier shall be provided that prevents the passage of a 4 inch diameter sphere, where any portion of the sphere is within 4 inches of the finish floor or ground surface.</li> <li>Edge-protection shall not be required when the floor or ground surface of the ramp run or landing extends 12 inches minimum beyond the inside face of a handrail.</li> <li>Edge protection shall not be required on curb ramps and their landings.</li> <li>Edge protection shall not be required on ramps that are not required to have handrails and have flares not steeper than 1:10.</li> <li>Edge protection shall not be required on the sides of ramp landings having a vertical drop-off of 1/2 inch maximum within 10 inches horizontally of the minimum landing area.</li> </ul>			



## HANDRAIL AND PEDESTRIAN GUARDRAIL (PROWAG R408)

Figures/Examples	Requirements <sup>1</sup>	YES	NO	NA
	<ul style="list-style-type: none"> <li>The clear width of walking surfaces shall be 4.0 feet minimum.</li> <li>Handrails are required on ramp runs with a rise greater than 6 inches and on certain stairways. Handrails are not required on walking surfaces with running slopes less than 1:20. Where required, handrails shall be provided on both sides of stairs and ramps.</li> <li>Handrails shall be continuous within the full length of each stair flight or ramp run. Inside handrails on switchback or dogleg stairs and ramps shall be continuous between flights or runs.</li> <li>Top of gripping surfaces of handrails shall be 34 inches minimum and 38 inches maximum vertically above walking surfaces, stair nosings, and ramp surfaces. Handrails shall be at a consistent height above walking surfaces, stair nosings, and ramp surfaces.</li> <li>Clearance between handrail gripping surfaces and adjacent surfaces shall be 1 1/2 inches minimum.</li> <li>Handrail gripping surfaces with a circular cross section shall have an outside diameter of 1 1/4 inches minimum and 2 inches maximum.</li> <li>Handrail gripping surfaces with a non-circular cross section shall have a perimeter dimension of 4 inches minimum and 6 1/4 inches maximum, and a cross-section dimension of 2 1/4 inches maximum.</li> <li>Handrail gripping surfaces and any surfaces adjacent to them shall be free of sharp or abrasive elements and shall have rounded edges.</li> <li>Handrails shall not rotate within their fittings.</li> <li>Ramp handrails shall extend horizontally above the landing for 12 inches minimum beyond the top and bottom of ramp runs. Extensions shall return to a wall, guard, or the landing surface, or shall be continuous to the handrail of an adjacent ramp run.</li> <li>At the top of a stair flight, handrails shall extend horizontally above the landing for 12 inches minimum beginning directly above the first riser nosing. Extensions shall return to a wall, guard, or the landing surface, or shall be continuous to the handrail of an adjacent stair flight.</li> <li>At the bottom of a stair flight, handrails shall extend at the slope of the stair flight for a horizontal distance at least equal to one tread depth beyond the last riser nosing. Extension shall return to a wall, guard, or the landing surface, or shall be continuous to the handrail of an adjacent stair flight.</li> <li>See Edge Protection section above (also PROWAG 406.8) for additional details.</li> </ul>			

### STAIRWAYS (PROWAG R407)

Figures/Examples	Requirements <sup>1</sup>	YES	NO	NA
	<ul style="list-style-type: none"> <li>All steps on a flight of stairs shall have uniform riser heights and uniform tread depths. Risers shall be 4 inches high minimum and 7 inches high maximum. Treads shall be 11 inches deep minimum.</li> <li>Open risers are not permitted.</li> <li>The radius of curvature at the leading edge of the tread shall be 1/2 inch maximum. Nosings that project beyond risers shall have the underside of the leading edge curved or beveled. Risers shall be permitted to slope under the tread at an angle of 30 degrees maximum from vertical. The permitted projection of the nosing shall extend 1 1/2 inches maximum over the tread below.</li> <li>Stairs shall have handrails complying with PROWAG 2005 R408.</li> </ul>			

### UNOBSTRUCTED REACH RANGES (PROWAG R406)

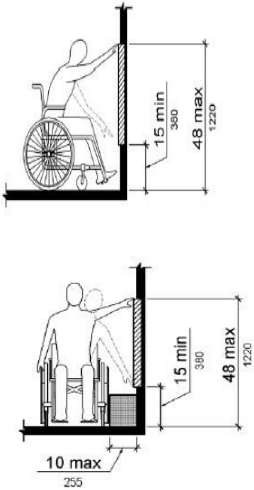
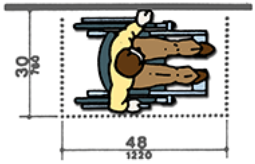
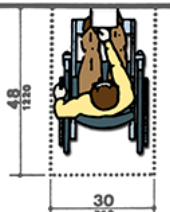
Figures/Examples	Requirements <sup>1</sup>	YES	NO	NA
	<p><b>Forward Reach</b></p> <ul style="list-style-type: none"> <li>Where a forward reach is unobstructed, the high forward reach shall be 48 inches maximum and the low forward reach shall be 15 inches minimum above the finish floor or ground.</li> </ul> <p><b>Side Reach</b></p> <ul style="list-style-type: none"> <li>Where a clear floor or ground space allows a parallel approach to an element and the side reach is unobstructed, the high side reach shall be 48 inches maximum and the low side reach shall be 15 inches minimum above the finish floor or ground.</li> <li><b>EXCEPTION:</b> An obstruction shall be permitted between the clear floor or ground space and the element where the depth of the obstruction is 10 inches maximum. (2011 PROWAG R406.3)</li> </ul> <div style="display: flex; justify-content: space-around; align-items: center;"> <div style="text-align: center;"> <p>Parallel Approach</p>  </div> <div style="text-align: center;"> <p>Forward Approach</p>  </div> </div>			



## CURB RAMPS (PROWAG R303)

Figures/Examples	Requirements <sup>1</sup>	YES	NO	NA
<p>A curb ramp, blended transition, or a combination of curb ramps and blended transitions shall connect the pedestrian access routes at each pedestrian street crossing.</p> <p><b>15 Foot Rule:</b> For a compliant curb ramp to exceed 8.33 percent running grade, its constructed length must exceed 15.0 feet.</p>	<ul style="list-style-type: none"> <li>• The clear width of ramps, excluding the flares, shall be 4.0 feet minimum.</li> <li>• Ramp runs shall have a running slope between 5 percent minimum and 8.33 percent maximum but shall not require the ramp length to exceed 15.0 feet.</li> </ul> <p><b>Exception: 15 Foot Rule:</b> The running slope for a curb ramp is not limited to 8.33 percent maximum if the constructed curb ramp length exceeds 15 feet in length.</p> <ul style="list-style-type: none"> <li>• Cross slope of ramp runs shall be 2 percent maximum. (Roadway Grade Exception may be considered)</li> <li>• The cross slope at midblock crossings shall be permitted to be warped to meet street or highway grade.</li> <li>• Ramps shall have landings at the top and the bottom of each ramp run.             <ul style="list-style-type: none"> <li>- The landing clear width shall be at least as wide as the widest ramp run leading to the landing.</li> <li>- The landing clear length shall be 5.0 feet long minimum.</li> <li>- Ramps that change direction between runs at landings shall have a clear landing 5.0 feet minimum by 5.0 feet minimum.</li> </ul> </li> <li>• Handrails and Edge protection shall not be required on curb ramps and their landings.</li> <li>• Curb height = 0 inches within curb ramp spaces. 2</li> <li>• Curb ramps must be flush with street.</li> <li>• The counter slope of the gutter or street at the foot of a curb ramp, landing, or blended transition shall be 5 percent maximum. (R303.3.5)</li> <li>• The adjacent surfaces at transitions at curb ramps to walks, gutters, and streets shall be at the same level.</li> <li>• Flared sides with a slope of 10 percent maximum, measured parallel to the curbline, shall be provided where a pedestrian circulation path crosses the curb ramp.             <ul style="list-style-type: none"> <li>- In alterations, where there is no landing at the top of curb ramps, curb ramp flares shall be provided and shall not be steeper than 1:12.</li> </ul> </li> <li>• Detectable warning surfaces shall be provided, where a curb ramp, landing, or blended transition connects to a street.</li> <li>• Gratings, access covers, and other appurtenances shall not be located on curb ramps, landings, blended transitions, and gutters within the pedestrian access route.</li> <li>• Grade breaks shall not be permitted on the surface of curb ramps, blended transitions, landings, and gutter areas within the pedestrian access route. Surface slopes that meet at grade breaks shall be flush.</li> <li>• Grade Breaks at the top and bottom of curb ramp runs shall be perpendicular to the direction of the ramp run.</li> </ul>			

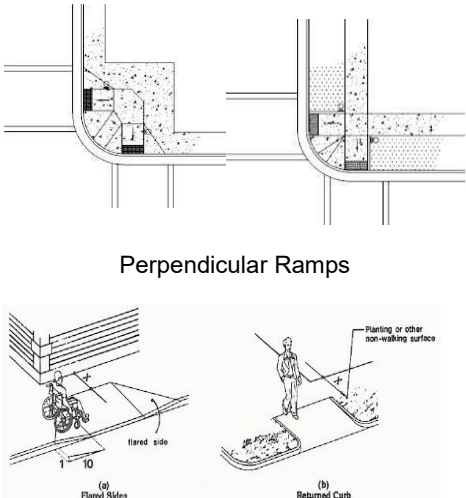
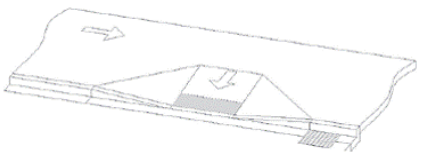
Figures/Examples	Requirements <sup>1</sup>	YES	NO	NA
 <p style="text-align: center;">Perpendicular Ramps</p> <p style="text-align: center;">(a) Flared Sides      (b) Returned Curb</p> <p style="text-align: center;">X = 4' Min. Flared Sides in Pathway      Flared Sides Not in Pathway</p> <p><b><u>Roadway Grade Exception:</u></b> Where curb ramps, landings and blended transitions are contained within a street or highway right-of-way, the grade of the pedestrian access route is permitted to be modified to equal the general grade established for the adjacent street or highway.</p> 	<ul style="list-style-type: none"> <li>• Perpendicular curb <b>ramps</b> shall have a running slope that cuts through or is built up to the curb at right angles or meets the gutter grade break at right angles.</li> <li>• The clear width of landings, blended transitions, and curb ramps, excluding flares, shall be 4.0 feet minimum.</li> <li>• The running slope shall be 5 percent minimum and 8.33 percent maximum but shall not require the ramp length to exceed 15.0 feet.</li> <li>• The cross slope at intersections shall be 2 percent maximum. (Roadway Grade Exception may be considered)</li> <li>• The cross slope at midblock crossings shall be permitted to be warped to meet street or highway grade.</li> </ul> <p><b><u>Roadway Grade Exception:</u></b> The grade of pedestrian access routes within sidewalks is permitted to equal the general grade established for the adjacent street or highway. The cross slope of curb ramps, blended transitions, landings, and turning spaces at pedestrian street crossings without yield or stop control where vehicles can proceed through the intersection without slowing or stopping, and at midblock pedestrian street crossings are permitted to equal the street or highway grade.</p> <ul style="list-style-type: none"> <li>• A landing 4.0 feet minimum by 4.0 feet minimum shall be provided at the top of the curb ramp and shall be permitted to overlap other landings and clear space.</li> <li>• Flared sides with a slope of 10 percent maximum, measured parallel to the curbline, shall be provided where a pedestrian circulation path crosses the curb ramp.</li> <li>• If the flared sides are not in the pathway (grass next to ramp), then there is no maximum slope and can be vertical curbs. (See adjacent figure for further explanation.)</li> <li>• Detectable warning surfaces shall be provided, where a curb ramp, landing, or blended transition connects to a street.</li> <li>• Gratings, access covers, and other appurtenances shall not be located on curb ramps, landings, blended transitions, and gutters within the pedestrian access route.</li> <li>• Grade breaks at the top and bottom of perpendicular curb ramps shall be perpendicular to the direction of ramp run. At least one end of the bottom grade break shall be at the back of curb.</li> <li>• Grade breaks shall not be permitted on the surface of curb ramps, blended transitions, landings, and gutter areas within the pedestrian access route. Surface slopes that meet at grade breaks shall be flush.</li> <li>• Where both ends of the bottom grade break are 5.0 feet or less from the back of curb, the detectable warning shall be located on the ramp surface at the bottom grade break. Where either end of the bottom grade break is more than 5.0 feet from the back of curb, the detectable warning shall be located on the lower landing.</li> </ul>			

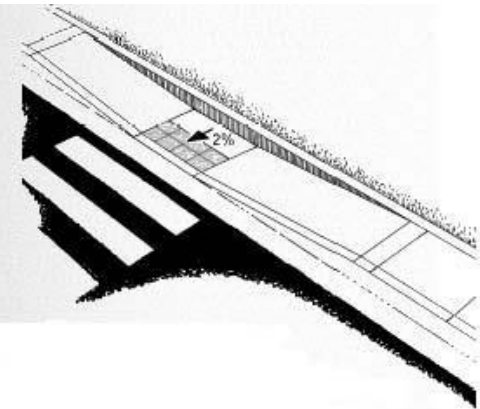
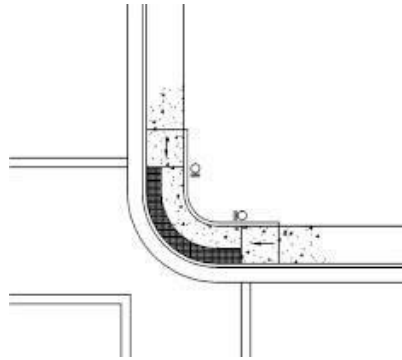

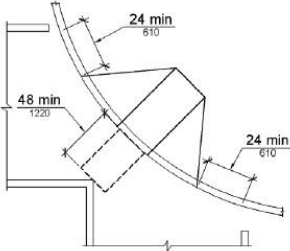
Figures/Examples	Requirements <sup>1</sup>	YES	NO	NA
 <p data-bbox="86 625 562 803">Curb Ramps and landings that are contained within a street or highway border may use the Roadway Grade Exception for slopes or cross slopes in the direction of the roadway travel being matched.</p>	<ul data-bbox="588 138 1722 406" style="list-style-type: none"> <li>• <b>Parallel curb ramps</b> shall have a running slope that is in-line with the direction of sidewalk travel.</li> <li>• The clear width of landings, blended transitions, and curb ramps, excluding flares, shall be 4.0 feet minimum.</li> <li>• The running slope shall be 5 percent minimum and 8.33 percent maximum but shall not require the ramp length to exceed 15.0 feet.</li> <li>• The cross slope shall be 2 percent maximum. (Roadway Grade Exception may be considered)</li> </ul> <p data-bbox="630 430 1743 633"><b>Roadway Grade Exception:</b> The grade of pedestrian access routes within sidewalks is permitted to equal the general grade established for the adjacent street or highway. The cross slope of curb ramps, blended transitions, landings, and turning spaces at pedestrian street crossings without yield or stop control where vehicles can proceed through the intersection without slowing or stopping, and at midblock pedestrian street crossings are permitted to equal the street or highway grade.</p> <ul data-bbox="588 657 1722 1063" style="list-style-type: none"> <li>• A landing 4.0 feet minimum by 4.0 feet minimum shall be provided at the bottom of the ramp run and shall be permitted to overlap other landings and clear floor or ground space.</li> <li>• Where a parallel curb ramp does not occupy the entire width of a sidewalk, drop-offs at diverging segments shall be protected.</li> <li>• Detectable warning surfaces shall be provided, where a curb ramp, landing, or blended transition connects to a street.</li> <li>• Gratings, access covers, and other appurtenances shall not be located on curb ramps, landings, blended transitions, and gutters within the pedestrian access route.</li> <li>• Grade breaks shall not be permitted on the surface of curb ramps, blended transitions, landings, and gutter areas within the pedestrian access route. Surface slopes that meet at grade breaks shall be flush.</li> </ul>			
	<ul data-bbox="588 1079 1743 1485" style="list-style-type: none"> <li>• <b>Blended Transitions</b> shall have a running slope of 5 percent maximum and cross slope shall be 2 percent maximum.</li> <li>• The clear width blended transitions, excluding flares, shall be 4.0 feet minimum.</li> <li>• Detectable warning surfaces shall be provided where a blended transition connects to a street.</li> <li>• Gratings, access covers, and other appurtenances shall not be located on blended transitions within the pedestrian access route.</li> <li>• Grade breaks at the top and bottom of perpendicular curb ramps shall be perpendicular to the direction of ramp run. At least one end of the bottom grade break shall be at the back of curb. Grade breaks shall not be permitted on the surface of blended transitions and gutter areas within the pedestrian access route. Surface slopes that meet at grade breaks shall be flush.</li> </ul>			

Figures/Examples	Requirements <sup>1</sup>	YES	NO	NA
 	<ul style="list-style-type: none"> <li>• <b>Diagonal Curb Ramps or corner type curb ramps are no longer preferred design types. A design that provides individual ramps for each crossing direction is recommended by the US Access Board.</b></li> <li>• Diagonal Curb Ramps or corner type curb ramps with returned curbs or other well-defined edges shall have the edges parallel to the direction of pedestrian flow.</li> <li>• The bottom of diagonal curb ramps shall have a clear space 48 inches minimum outside active traffic lanes of the roadway.</li> <li>• Diagonal curb ramps provided at marked crossings shall provide the 48 inches minimum clear space within the markings.</li> <li>• Diagonal curb ramps with flared sides shall have a segment of curb 24 inches long minimum located on each side of the curb ramp and within the marked crossing.</li> </ul> <p><b>Roadway Grade Exception:</b> The grade of pedestrian access routes within sidewalks is permitted to equal the general grade established for the adjacent street or highway. The cross slope of curb ramps, blended transitions, landings, and turning spaces at pedestrian street crossings without yield or stop control where vehicles can proceed through the intersection without slowing or stopping, and at midblock pedestrian street crossings are permitted to equal the street or highway grade.</p> <ul style="list-style-type: none"> <li>• Detectable warning surfaces shall be provided, where a curb ramp, landing, or blended transition connects to a street.</li> <li>• Gratings, access covers, and other appurtenances shall not be located on curb ramps, landings, blended transitions, and gutters within the pedestrian access route.</li> <li>• Grade breaks shall not be permitted on the surface of curb ramps, blended transitions, landings, and gutter areas within the pedestrian access route. Surface slopes that meet at grade breaks shall be flush.</li> <li>• Running and cross slope at midblock crossings shall be permitted to be warped to meet street or highway grade.</li> </ul>			

**DETECTABLE WARNINGS DEVICES (TRUNCATED DOMES) (PROWAG R304)**



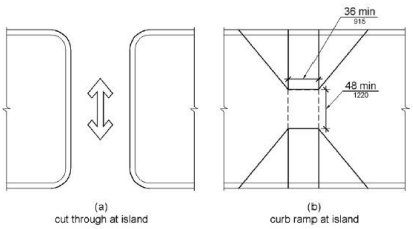

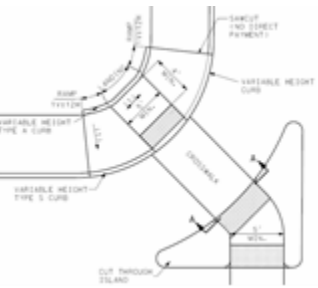
Figures/Examples	Requirements <sup>1</sup>	YES	NO	NA
<p>A surface feature of truncated dome material built in or applied to the walking surface to advise of an upcoming change from pedestrian to vehicular way.</p>	<ul style="list-style-type: none"> <li>• Detectable warnings shall consist of a surface of truncated domes aligned in a square or radial grid pattern complying with 2010 ADA Standards. Detectable warning surfaces shall contrast visually with adjacent gutter, street or highway, or walkway surfaces, either light-on-dark or dark-on-light.</li> <li>• Detectable warning surfaces shall extend 24 inches minimum in the direction of travel and the full width of the curb ramp (exclusive of flares), the landing, or the blended transition. Detectable warning surfaces are required where curb ramps, blended transitions, or landings provide a flush pedestrian connection to the street.</li> <li>• Sidewalk crossings of residential driveways should not generally be provided with detectable warnings, since the pedestrian right-of-way continues across most driveway aprons and overuse of detectable warning surfaces should be avoided in the interests of message clarity. However, where commercial driveways are provided with traffic control devices or otherwise are permitted to operate like public streets, detectable warnings should be provided at the junction between the pedestrian route and the street.</li> <li>• Perpendicular Curb Ramps: Where both ends of the bottom grade break are 5 feet or less from the back of curb, the detectable warning shall be located on the ramp surface at the bottom grade break. Where either end of the bottom grade break is more than 5 feet from the back of curb, the detectable warning shall be located on the lower landing.</li> <li>• Landings and Blended Transitions: The detectable warning shall be located on the landing or blended transition at the back of curb.</li> <li>• Rail Crossings: The detectable warning surface shall be located so that the edge nearest the rail crossing is 6 feet minimum and 15 feet maximum from the centerline of the nearest rail. The rows of truncated domes in a detectable warning surface shall be aligned to be parallel with the direction of wheelchair travel.</li> <li>• Detectable warnings at cut-through islands shall be located at the curb line in-line with the face of curb and shall be separated by a 2.0 foot minimum length of walkway without detectable warnings. Where the island has no curb, the detectable warning shall be located at the edge of roadway.</li> <li>• Exception, when detectable warnings are required by a manufacturer's installation specifications to be embedded into concrete with a surrounding edge, domes may be installed at less than the required full width. Under this exception, the detectable warning surface shall never be more than 2 inches from the edge of the curb ramp, the landing, or the blended transition. <sup>2</sup></li> <li>• Detectable warnings shall not be stamped into concrete.</li> </ul>			

## ISLANDS AND MEDIANS (PROWAG R305.4)



Figures/Examples	Requirements <sup>1</sup>	YES	NO	NA
  	<ul style="list-style-type: none"> <li>Medians and pedestrian refuge islands in crosswalks shall contain a pedestrian access route, including passing space and connecting to each crosswalk.</li> <li>Raised islands in crossings shall be cut through level with the street or have curb ramps and required landings at both sides.</li> <li>All median island passage spaces shall provide a clear width of 5 feet minimum. <sup>2</sup></li> <li>Medians and pedestrian refuge islands shall be 6.0 feet minimum in length in the direction of pedestrian travel.</li> </ul> <p><b><u>Roadway Grade Exception:</u></b> The grade of pedestrian access routes within sidewalks is permitted to equal the general grade established for the adjacent street or highway. The cross slope of curb ramps, blended transitions, landings, and turning spaces at pedestrian street crossings without yield or stop control where vehicles can proceed through the intersection without slowing or stopping, and at midblock pedestrian street crossings are permitted to equal the street or highway grade.</p> <ul style="list-style-type: none"> <li>Each curb ramp shall have a level area 48 inches long minimum by 36 inches wide minimum at the top of the curb ramp in the part of the island intersected by the crossings.</li> <li>Each 48 inch minimum by 36 inch minimum area shall be oriented so that the 48 inch minimum length is in the direction of the running slope of the curb ramp it serves. The 48 inch minimum by 36 inch minimum areas and the accessible route shall be permitted to overlap.</li> <li>Detectable warning surfaces shall be provided, where a curb ramp, landing, or blended transition connects to a street. Medians and pedestrian refuge islands shall have detectable warnings at curb ramps and blended transitions.</li> <li>Detectable warnings at cut-through islands shall be located at the curb line in-line with the face of curb and shall be separated by a 2.0 foot minimum length of walkway without detectable warnings. Where the island has no curb, the detectable warning shall be located at the edge of roadway.</li> <li>Gratings, access covers, and other appurtenances shall not be located on curb ramps, landings, blended transitions, and gutters within the pedestrian access route.</li> <li>Grade breaks shall not be permitted on the surface of curb ramps, blended transitions, landings, and gutter areas within the pedestrian access route. Surface slopes that meet at grade breaks shall be flush.</li> </ul>			



**ACCESSIBLE PEDESTRIAN SIGNALS (PUSHBUTTONS) (PROWAG R306 and EPG 902.6.1 – EPG 902.6.15)**

Figures/Examples	Requirements <sup>1</sup>	YES	NO	NA
    	<ul style="list-style-type: none"> <li>• Each crosswalk with pedestrian signal indication shall have an accessible pedestrian signal which includes audible and vibrotactile indications of the WALK interval at new signalized intersections and shall be considered at existing intersections being altered or are needing maintenance applications. Where a pedestrian pushbutton is provided, it shall be integrated into the accessible pedestrian signal.</li> <li>• Accessible pedestrian signals shall be located so that the vibrotactile feature can be contacted from the level landing serving a curb ramp, if provided, or from a clear floor or ground space that is in line with the crosswalk line adjacent to the vehicle stop line.</li> <li>• Accessible pedestrian pushbuttons shall be located within a reach range complying with EPG 642.</li> <li>• A clear floor or ground space shall be provided at the pushbutton and shall connect to or overlap the pedestrian access route.</li> </ul> <p><b>Roadway Grade Exception:</b> Clear spaces required at accessible pedestrian signals and pedestrian pushbuttons and at other accessible elements are permitted to have a running slope or cross slope consistent with the grade of the adjacent pedestrian access route.</p> <ul style="list-style-type: none"> <li>• Pedestrian signals shall comply with PROWAG 2005 R306 and EPG 902.6.1 through 902.6.15.             <ul style="list-style-type: none"> <li>- Pushbuttons are a minimum 2 inches across in one dimension, raised (not recessed), contrast visually with the housing or mounting, and have a maximum force of 3.5 pounds to activate operable parts.</li> <li>- The control face of the pushbuttons is installed parallel to the direction of the crosswalk it serves.</li> <li>- The location of pushbuttons for new construction are within a longitudinal distance of 5 feet maximum from the crosswalk line, and 30 inches minimum to 6 feet maximum from the curb line.</li> <li>- For audible pedestrian signal devices only, pushbuttons are a minimum 10 feet apart.</li> <li>- Pushbuttons are located at a height of approximately 42 inches, but no higher than 48 inches from the ground and within 10 inch reach from a level paved clear floor or ground space with minimum dimensions of 48 inches x 30 inches positioned for a parallel approach to the pushbutton. For a forward approach space (30 x 48 inches) the allowed reach range is 0 inches.</li> <li>- Where pushbuttons for the visually impaired are installed, tactile signs are to be provided that meet ADA requirements.</li> </ul> </li> </ul>			

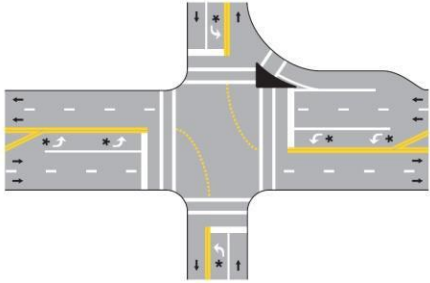
**PEDESTRIAN STREET CROSSINGS (PROWAG R305 and EPG 642)**

Figures/Examples	Requirements <sup>1</sup>	YES	NO	NA
 	<ul style="list-style-type: none"> <li>• Crosswalks shall contain a pedestrian access route that connects to departure and arrival walkways through any median or pedestrian refuge island.</li> <li>• Marked crosswalks shall be 6 feet wide minimum.</li> <li>• The grade of the pedestrian access route is permitted to equal the general grade established for the adjacent street or highway, except that where pedestrian access routes are contained within pedestrian street crossings a maximum grade of 5 percent is required.</li> <li>• A 5 percent maximum cross slope is specified for pedestrian access routes contained within pedestrian street crossings without yield or stop control.</li> <li>• Crossings with Stop Control: The cross slope shall be 2 percent maximum.</li> <li>• The cross slope at midblock crossings shall be permitted to be warped to meet street or highway grade.</li> <li>• The running slope shall be 5 percent maximum, measured parallel to the direction of pedestrian travel in the crosswalk.</li> <li>• Accessible pedestrian signals and pedestrian pushbuttons provided at pedestrian crossings with pedestrian signals (See EPG 642 for applicability) shall comply with EPG 902.6.8 through 902.6.15. Operable parts shall comply with EPG 902.6.9 – 902.6.15.</li> <li>• Crosswalk pavement marking is 6 inches wide white.</li> <li>• Stop bar is at minimum 4 feet from the crosswalk.</li> <li>• Curb ramps at marked crossings shall be wholly contained within the markings, excluding any flared sides.</li> <li>• Gratings, access covers, and other appurtenances shall not be located on curb ramps, landings, blended transitions, and gutters within the pedestrian access route.</li> <li>• Grade breaks shall not be permitted on the surface of curb ramps, blended transitions, landings, and gutter areas within the pedestrian access route. Surface slopes that meet at grade breaks shall be flush.</li> <li>• Beyond the curb face, a clear space of 4.0 feet minimum by 4.0 feet minimum shall be provided within the width of the crosswalk and wholly outside the parallel vehicle travel lane.</li> </ul>			



**ALTERNATE CIRCULATION PATH (PROWAG R302)**

Figures/Examples	Requirements <sup>1</sup>	YES	NO	NA
	<ul style="list-style-type: none"> <li>• Alternate circulation paths shall contain a pedestrian access route.</li> <li>• To the maximum extent feasible, the alternate circulation path shall be provided on the same side of the street as the disrupted route.</li> <li>• Where the alternate circulation path is exposed to adjacent construction, excavation drop-offs, traffic, or other hazards, it shall be protected with a pedestrian barricade or channelizing device complying with MUTCD 6F-58, 6F-63, and 6F-66.</li> <li>• Pedestrian barricades and channelizing devices shall be continuous, stable, and non-flexible and shall consist of a wall, fence, or enclosures specified in section 6F-58, 6F-63, and 6F-66 of the MUTCD (incorporated by reference; see PROWAG 2005 R104.2.4).</li> <li>• A detectable continuous bottom edge shall be provided 2 inches maximum above the ground or walkway surface.</li> <li>• Devices shall provide a continuous surface or upper rail at 3.0 feet minimum above the ground or walkway surface.</li> <li>• Support members shall not protrude into the alternate circulation path.</li> </ul>			

**BUS BOARDING AND ALIGHTING AREAS (PROWAG R410)**

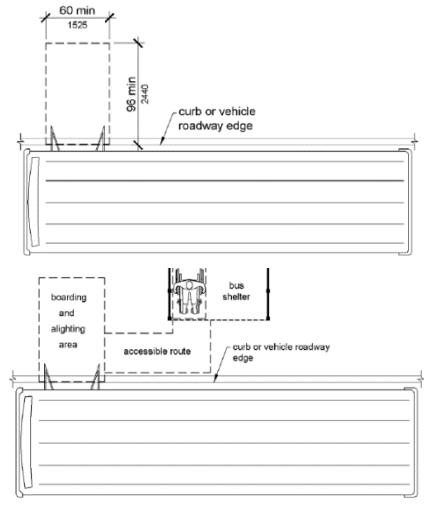
Figures/Examples	Requirements <sup>1</sup>	YES	NO	NA
	<ul style="list-style-type: none"> <li>• Bus stop boarding and alighting areas shall have a firm, stable surface.</li> <li>• Bus stop boarding and alighting areas shall provide a clear length of 8 feet minimum, measured perpendicular to the curb or vehicle roadway edge, and a clear width of 5 feet minimum, measured parallel to the vehicle roadway.</li> <li>• Bus stop boarding and alighting areas shall be connected to streets, sidewalks, or pedestrian paths by an accessible route.</li> <li>• Parallel to the roadway, the slope of the bus stop boarding and alighting area shall be the same as the roadway, to the maximum extent practicable. Perpendicular to the roadway, the slope of the bus stop boarding and alighting area shall not be steeper than 2 percent.</li> <li>• Bus shelters shall provide a minimum 30 inch by 48 inch clear floor or ground space entirely within the shelter.</li> <li>• Bus shelters shall be connected by an accessible route to a boarding and alighting area.</li> </ul>			

<sup>1</sup> Any “NO” answer means that location is ADA non-compliant and needs to be corrected before final acceptance of the work, except as follows. Although exceptions listed in the above requirements may not meet MoDOT current policy standards, work that does meet the minimum ADA standards will be accepted as ADA compliant. Where it is technically infeasible to correct deficiencies as part of the current work, those locations will be labeled as non-compliant and marked “NO”. These items will be added to the Transition Plan Inventory for correction at a later date. (Guidance is provided in ADA documents and in the EPG on what may be considered as technically infeasible.)

<sup>2</sup> A MoDOT requirement.

**Unless otherwise noted, all notes on this form are direct ADA requirements as published in either the PROWAG dated November 23, 2005 or ADA/ABA Standards from 2010.**

All exceptions and technically infeasible locations should be discussed with the project manager and/or area engineer prior to acceptance of the work. All exceptions and technically infeasible locations will need to be thoroughly documented by the engineer, and that documentation will be attached to this form and retained as part of the final acceptance records.

All slope and grade measurements for ADA compliance will be made using a calibrated 2 foot long digital level.

**US Access Board PROWAG**

**R202.3.1 Prohibited Reduction in Required Access.** An alteration shall not decrease or have the effect of decreasing the accessibility of a facility or an accessible connection to an adjacent building or site below the requirements for new construction in effect at the time of the alteration.

<b>Inspector Name:</b> _____ <b>Inspector Signature:</b> _____	<b>Date:</b>
<b>Contractor Representative Name:</b> _____ <b>Contractor Representative Signature:</b> _____	<b>Date:</b>
<b>Resident Engineer or Area Engineer Name:</b> _____ <b>Resident Engineer or Area Engineer Signature:</b> _____	<b>Date:</b>
<b>Distribution:</b> <input type="checkbox"/> <b>Project Office</b> <input type="checkbox"/> <b>District Permit Office</b>	

# ***SAMPLE***

## **ADA EXCEPTIONS DOCUMENTATION**

Job No. \_\_\_\_\_ Route \_\_\_\_\_ County \_\_\_\_\_ Location \_\_\_\_\_

<u>Item</u>	<u>Location</u>	<u>Standard</u>	<u>As Built</u>	<u>Discussion</u>
Sidewalk Width	Third Street Sta 3+00 to 7+00 RT	5' wide	Exist 3' wide	Required 5' x 5' Passing Space added at 5+00
Curb Ramp Grade	SE Quad of Main & First	8.33%	11.2%	As-built Curb Ramp is 16.0' long
Parallel Ramp Landing running grade (turning space)	Sta 35+20 to 35+25 Rt Rte 14	2.00%	2.6%	Landing running grade matches existing roadway grade
Sidewalk Grade	Sta 23+45 to 23+52	5.0%	8.4%	Match existing floor at two exist doorways, Straight grade between fixed elevations

Inspector Name: _____	
Inspector Signature: _____	<b>Date:</b>
Resident Engineer or Area Engineer Name: _____	
Resident Engineer or Area Engineer Signature: _____	<b>Date:</b>
<b>Distribution:</b> <input type="checkbox"/> Project Office <input type="checkbox"/> District Permit Office	

# CITY OF ST. MARTINS, MISSOURI

## PLANS FOR PROPOSED MILLING, OVERLAY, AND STRIPING ON CAREL RD., O'ROURKE ST., AND HENWICK LN., G16696

SEPTEMBER 19, 2025

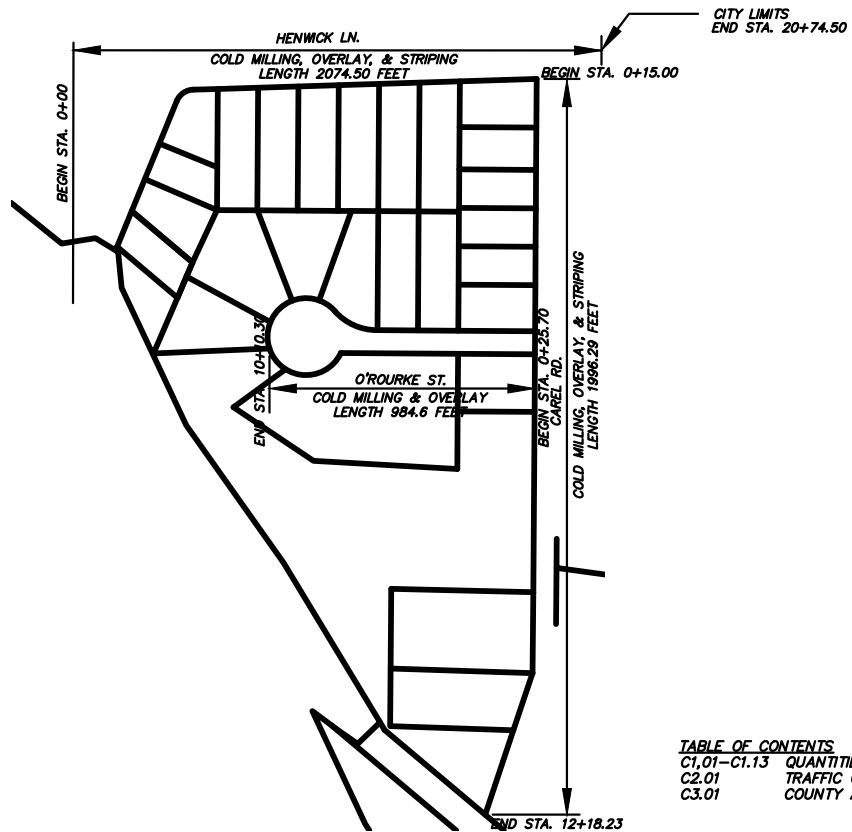

**TABLE OF CONTENTS**

C1.01-C1.13	QUANTITIES
C2.01	TRAFFIC CONTROL
C3.01	COUNTY ADD ALTERNATE

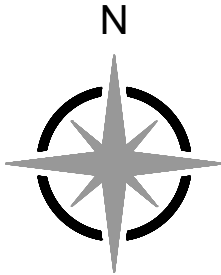

**SITE LOCATION MAP**  
NOT TO SCALE



**Engineering Surveys  
& Services**

DELIVERING YOUR VISION™

Missouri Engineering Corp. # 2004005018



APPROVED BY THE PLANNING AND ZONING COMMISSION,  
ST. MARTINS, MISSOURI, ON \_\_\_\_\_

\_\_\_\_\_  
DARYL RATHIEL, MAYOR

\_\_\_\_\_  
DOUG REECE, CITY ADMINISTRATOR

IF ORIGINAL SIGNATURE OR DIGITAL  
AUTHENTICATION IS NOT PRESENT THIS  
MEDIA SHOULD NOT BE CONSIDERED A  
CERTIFIED DOCUMENT.

09/19/2025

STATE OF MISSOURI

KELLY A. LOHSANDT

NUMBER

PE-2021032813

PROFESSIONAL ENGINEER

*Kelly A. Lohsandt*

KELLY A. LOHSANDT  
PROFESSIONAL ENGINEER  
PE-2021032813

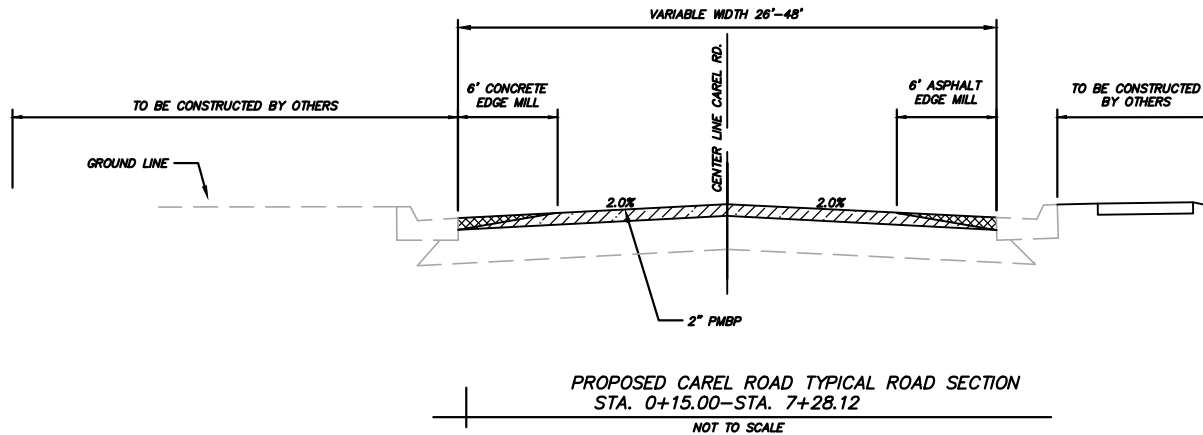
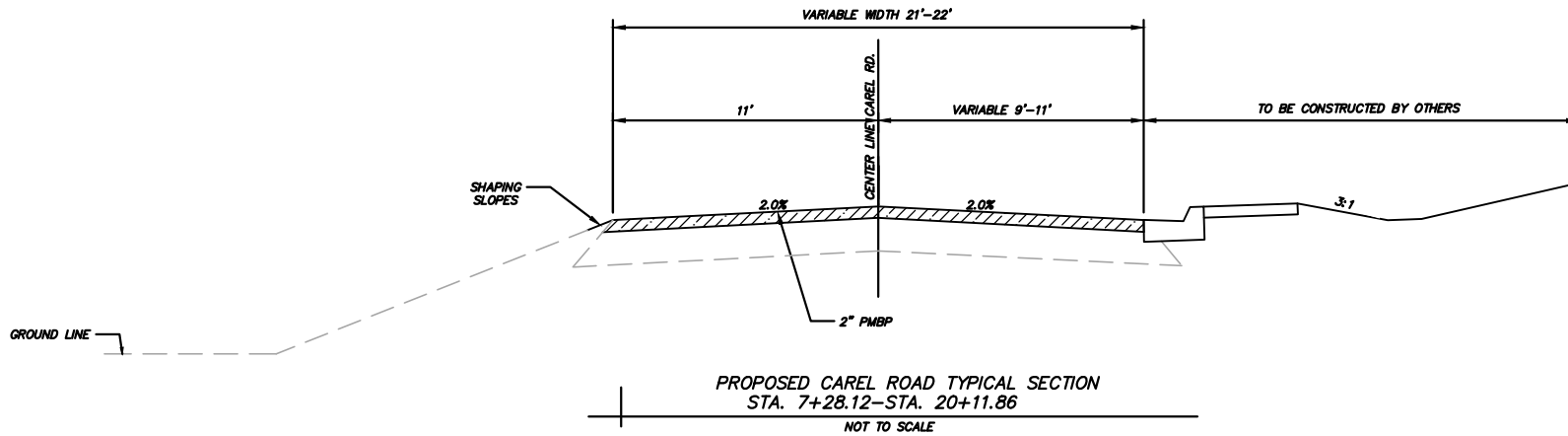

IF ORIGINAL SIGNATURE OR DIGITAL AUTHENTICATION IS NOT PRESENT THIS MEDIA SHOULD NOT BE CONSIDERED A CERTIFIED DOCUMENT.

09/19/2025



G16696  
C-1.01

ST. MARTINS, COLE COUNTY, MISSOURI



Missouri Engineering Corp. # 2004005018

TYPICAL SECTION

09/19/2025

KELLY A. LOHSANDT  
PROFESSIONAL ENGINEER  
PE-2021032813

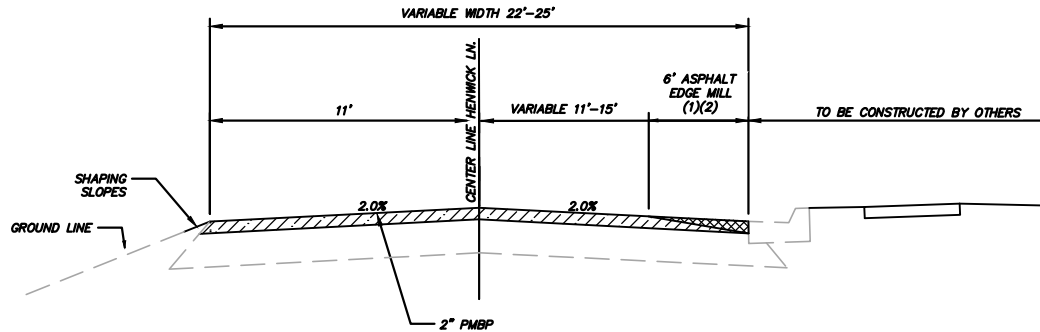

PROPOSED HENWICK LN TYPICAL SECTION  
STA. 1+50.35-STA. 16+74.43

NOT TO SCALE

NOTES

- (1) EXCEPT EDGE MILLING FROM STA. LIMITS OF NEW CURB AND GUTTER STA. 1+50.35-STA. 3+57.35 AND STA. 4+48.43-STA. 4+91.76.
- (2) CONCRETE EDGE MILL FROM STA. 16+57.43-STA. 16+74.43.
- (3) EDGE MILL THROUGH THE LIMITS OF BUSINESS 50 AND RABBIT RUN TO MATCH EXISTING.

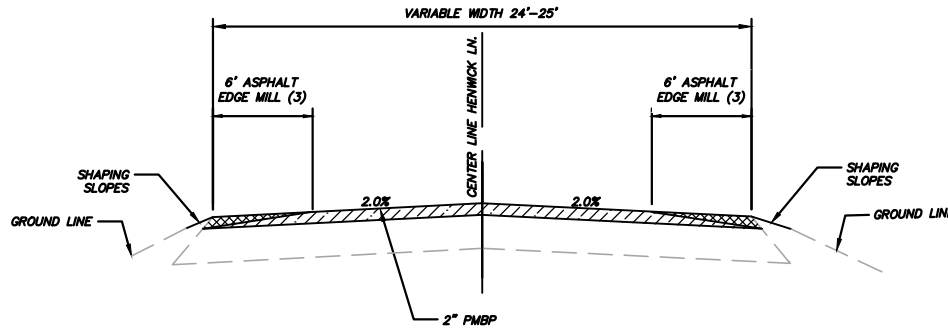

PROPOSED HENWICK LN TYPICAL SECTION  
STA. 0+00-STA. 1+50.35

NOT TO SCALE

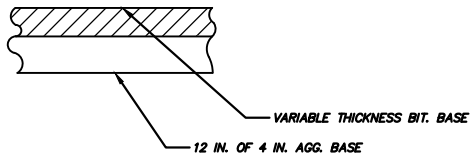

PAVEMENT REPAIR TYPICAL SECTION

NOT TO SCALE

IF ORIGINAL SIGNATURE OR DIGITAL AUTHENTICATION IS NOT PRESENT THIS MEDIA SHOULD NOT BE CONSIDERED A CERTIFIED DOCUMENT.

09/19/2025



G16696

C-1.02

ST. MARTINS, COLE COUNTY, MISSOURI

TYPICAL SECTION

09/19/2025

KELLY A. LOHSANDT  
PROFESSIONAL ENGINEER  
PE-2021032813



Missouri Engineering Corp. # 2004005018

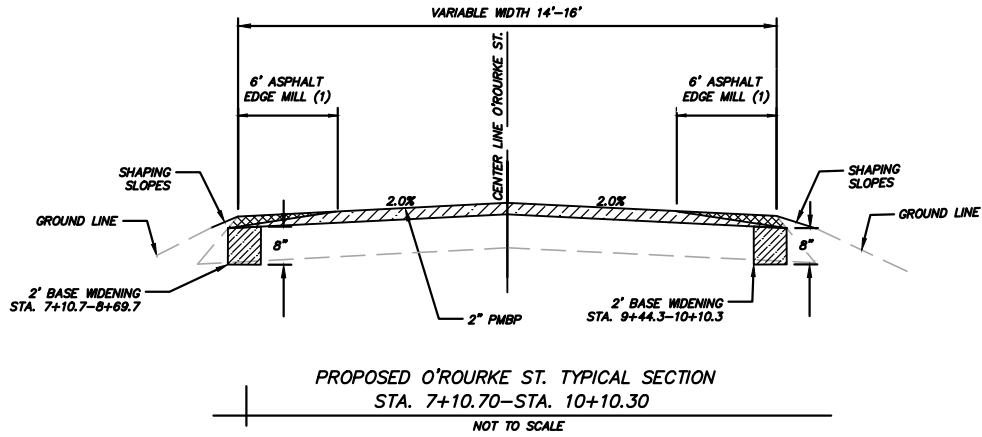

**NOTES**  
 (1) EDGE MILL THROUGH THE LIMITS OF ALL DRIVEWAYS TO MATCH EXISTING.  
 (2) EDGE MILL LIMITS OF EXISTING CURB AND GUTTER TO MATCH EXISTING.

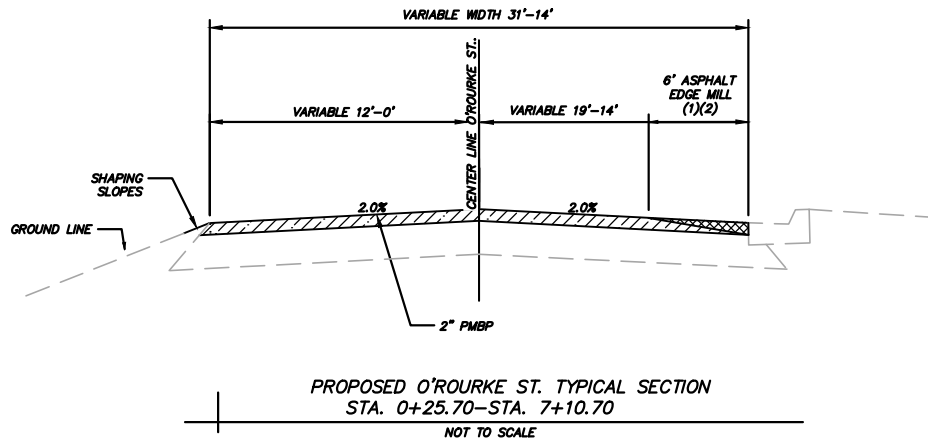

IF ORIGINAL SIGNATURE OR DIGITAL AUTHENTICATION IS NOT PRESENT THIS MEDIA SHOULD NOT BE CONSIDERED A CERTIFIED DOCUMENT.

09/19/2025



G16696  
C-1.03

ST. MARTINS, COLE COUNTY, MISSOURI



TYPICAL SECTION

09/19/2025

Missouri Engineering Corp. # 2004005018

KELLY A. LOHSANDT  
PROFESSIONAL ENGINEER  
PE-2021032813

PAVING SCHEDULE					
STATION	2" BITUMINOUS PAVEMENT	BASE WIDENING	TACK COAT	SHAPING SLOPES CL 2	REMARKS
	(TONS)	(TONS)	(GALLONS)	(STA.)	
CAREL ROAD					
STA. 0+15.00 - STA. 12+18.23	640.0		540.0	13.0	
HENWICK LANE					
STA. 0+00.00 - STA. 20+74.50	710.0		550.0	25.0	
O'ROURKE STREET					
STA. 0+25.70 - STA. 10+10.30	290.0		240.0	13.0	
STA. 7+10.70 - STA. 8+69.70		15.0			
STA. 9+44.30 - STA. 10+10.30		7.0			
SUBTOTAL	1640.0	22.0	1330.0	51.0	
TOTAL	1640.0	22.0	1330.0	51.0	

NOTE:  
ASPHALT QUANTITIES INCLUDE 10%  
FOR RUTTING AND IRREGULARITIES.

IF ORIGINAL SIGNATURE OR DIGITAL AUTHENTICATION IS NOT PRESENT THIS MEDIA SHOULD NOT BE CONSIDERED A CERTIFIED DOCUMENT.

09/19/2025



G16696  
C-1.04  
ST. MARTINS, COLE COUNTY, MISSOURI



2B - SHEET  
09/19/2025

Missouri Engineering Corp. # 2004005018

KELLY A. LOHSANDT  
PROFESSIONAL ENGINEER  
PE-2021032813



MILLING SCHEDULE				
STATION	ASPHALT EDGE MILL	CONCRETE EDGE MILL	"MODIFIED COLDMILLING "	REMARKS
	(SQ YD)	(SQ YD)	(SQ YD)	
CAREL ROAD				
STA.0+15.00 TO STA. 7+71.00	680.0	720.0		MATCH EXISTING GUTTER
STA. 9+70.00 - STA. 11+10.00 LT.	93.0			DRIVEWAY MATCH EXISTING
STA. 14+97.57 - STA. 16+31.57 LT.	100.0			DRIVEWAY MATCH EXISTING
STA. 19+11.86 - STA. 20+11.86			240	DEPTH TRANSITION
SUBTOTAL	873.0	720.0	240	

IF ORIGINAL SIGNATURE OR DIGITAL AUTHENTICATION IS NOT PRESENT THIS MEDIA SHOULD NOT BE CONSIDERED A CERTIFIED DOCUMENT.

09/19/2025



G16696  
C-1.05  
ST. MARTINS, COLE COUNTY, MISSOURI



Missouri Engineering Corp. # 2004005018

2B - SHEET  
09/19/2025

KELLY A. LOHSANDT  
PROFESSIONAL ENGINEER  
PE-2021032813

MILLING SCHEDULE				
STATION	ASPHALT EDGE MILL	CONCRETE EDGE MILL	"MODIFIED COLDMILLING "	REMARKS
	(SQ YD)	(SQ YD)	(SQ YD)	
HENWICK LANE				
STA. 0+00.00 - STA. 1+00.00			212.0	DEPTH TRANSITION
STA.0+25.00 - STA. 1+66.40 LT & RT	160.0			BUS. 50 & RABIT RUN MATCH EXIST
STA. 5+17.30- STA. 16+07.51 RT.	731.0			MATCH EXISTING GUTTER
STA. 7+19.48 - STA. 8+40.79	80.0			DRIVEWAY MATCH EXISTING
STA. 8+30.05 - STA. 9+49.03	76.0			DRIVEWAY MATCH EXISTING
STA.9+40.42 - STA. 10+54.16	75.0			DRIVEWAY MATCH EXISTING
SUBTOTAL	1047.0		212	

IF ORIGINAL SIGNATURE OR DIGITAL AUTHENTICATION IS NOT PRESENT THIS MEDIA SHOULD NOT BE CONSIDERED A CERTIFIED DOCUMENT.

09/19/2025



G16696  
C-1.06  
ST. MARTINS, COLE COUNTY, MISSOURI  
2B - SHEET  
09/19/2025



Missouri Engineering Corp. # 2004005018

KELLY A. LOHSANDT  
PROFESSIONAL ENGINEER  
PE-2021032813

MILLING SCHEDULE				
STATION	ASPHALT EDGE MILL	CONCRETE EDGE MILL	"MODIFIED COLDMILLING "	REMARKS
	(SQ YD)	(SQ YD)	(SQ YD)	
O'ROURKE STREET				
STA. 0+25.70 - STA 1+25.70			278	DEPTH TRANSITION
STA. 0+25+70 - STA. 7+10.70 RT	458.0			MATCH EXISTING GUTTER
STA. 0+61.96 - STA 1+82.76 LT	80.0			DRIVEWAY MATCH EXISTING
STA. 1+91.82 - STA 3+08.40 LT	77.0			DRIVEWAY MATCH EXISTING
STA. 6+60.10 - STA. 781.12 RT	80.0			DRIVEWAY MATCH EXISTING
STA. 8+15.90 - STA. 8+95.73 RT.	53.0			DRIVEWAY MATCH EXISTING
SUBTOTAL	695.0		278	
TOTAL	2615	720	730	

IF ORIGINAL SIGNATURE OR DIGITAL AUTHENTICATION IS NOT PRESENT THIS MEDIA SHOULD NOT BE CONSIDERED A CERTIFIED DOCUMENT.

09/19/2025



G16696  
C-1.07  
ST. MARTINS, COLE COUNTY, MISSOURI



Missouri Engineering Corp. # 2004005018

2B - SHEET  
09/19/2025

KELLY A. LOHSANDT  
PROFESSIONAL ENGINEER  
PE-2021032813

PAVEMENT MARKING SCHEDULE			
	4" YELLOW SKIPS	4" DOUBLE SOLID YELLOW	REMAORKS
	(FOOT)	(FOOT)	
CAREL ROAD			
STA. 0+15.00 - STA. 12+18.23	500.0		
HENWICK LN.			
STA. 0+00.00 - STA. 20+74.50		4160.0	
TOTAL	500.0	4160.0	

<b>MOBILIZATION</b>
1 LUMP SUM

IF ORIGINAL SIGNATURE OR DIGITAL AUTHENTICATION IS NOT PRESENT THIS MEDIA SHOULD NOT BE CONSIDERED A CERTIFIED DOCUMENT.

09/19/2025



G16696  
C-1.08  
ST. MARTINS, COLE COUNTY, MISSOURI



2B - SHEET  
09/19/2025

Missouri Engineering Corp. # 2004005018

KELLY A. LOHSANDT  
PROFESSIONAL ENGINEER  
PE-2021032813

ASPHALT PAVEMENT REPAIR - HENWICK LANE				
STATION	PVT REP. REMOVAL	BITUMINOUS BASE (PAVEMENT REPAIR)	SUBGRADE STABILIZATION	REMARKS
	SY	TON	SY	
STA. 0+00.00 - STA. 0+62.00	91	50		4 IN. DEEP 29 FT. WIDE
STA. 1+74.00 - STA. 2+04.00	73	33	87	8 IN DEEP 22 FT. WIDE
STA. 2+04.00 - STA. 2+19.00	37	13	43	6 IN DEEP 22 FT. WIDE
STA. 2+19.00 - STA. 2+82.00	91	41	119	6 IN DEEP 13 FT. WIDE
STA. 5+20.56 - STA. 5+82.56	69	23	110	6 IN. DEEP 10 FT. WIDE
STA. 6+34.56 - STA. 7+01.56	81.9	28	82	6 IN. DEEP 11 FT. WIDE
<b>TOTAL:</b>	<b>443</b>	<b>188</b>	<b>441</b>	

IF ORIGINAL SIGNATURE OR DIGITAL AUTHENTICATION IS NOT PRESENT THIS MEDIA SHOULD NOT BE CONSIDERED A CERTIFIED DOCUMENT.

09/19/2025



G16696  
C-1.09  
ST. MARTINS, COLE COUNTY, MISSOURI  
  
Missouri Engineering Corp. # 2004005018

2B - SHEET  
09/19/2025

*Kelly A. Lohsandt*

KELLY A. LOHSANDT  
PROFESSIONAL ENGINEER  
PE-2021032813

TEMPORARY TRAFFIC CONTROL				
ROAD WORK AHEAD (48X48) 16 SF (2)	ONE LANE ROAD AHEAD (48x48) 16 SF (7)	FLAGGER SYMBOL (48x48) 16 SF (8)	TRIMLINE CHANNELIZERS	REMARKS
(SF)	(SF)	(SF)	(EACH)	
64	64	64	10	
TOTAL			10	
192				

IF ORIGINAL SIGNATURE OR DIGITAL AUTHENTICATION IS NOT PRESENT THIS MEDIA SHOULD NOT BE CONSIDERED A CERTIFIED DOCUMENT.

09/19/2025



KELLY A. LOHSANDT  
PROFESSIONAL ENGINEER  
NUMBER PE-2021032813

*Kelly Lohsandt*

KELLY A. LOHSANDT  
PROFESSIONAL ENGINEER  
PE-2021032813

G16696  
C-1.10  
ST. MARTINS, COLE COUNTY, MISSOURI  
2B - SHEET  
09/19/2025



Missouri Engineering Corp. # 2004005018

Gravel A		
Station	4"	Remarks
	Gravel A (S.Y)	
Henwick Lane		
6+65.00 LT.	98.0	
7+56.00 LT.	18.0	
13+30.50 LT.	17.0	
14+57.50 LT.	6.0	
14+90.39 LT.	27.0	
15+17.11 LT.	23.0	
18+84.91 RT.	6.0	
20+69.83 RT.	15.0	
Subtotal	210.0	

IF ORIGINAL SIGNATURE OR DIGITAL AUTHENTICATION IS NOT PRESENT THIS MEDIA SHOULD NOT BE CONSIDERED A CERTIFIED DOCUMENT.

09/19/2025



G16696  
 C-1.11  
 ST. MARTINS, COLE COUNTY, MISSOURI  
  
 Missouri Engineering Corp. # 2004005018  
 2B - SHEET  
 09/19/2025

KELLY A. LOHSANDT  
 PROFESSIONAL ENGINEER  
 PE-2021032813

Gravel A		
Station	4" Gravel A	Remarks
	(S.Y)	
Carel Road		
9+83.63 LT.	28.0	
14+21.45 LT.	18.0	
14+95.19 LT.	24.0	
Subtotal	70.0	

IF ORIGINAL SIGNATURE OR DIGITAL AUTHENTICATION IS NOT PRESENT THIS MEDIA SHOULD NOT BE CONSIDERED A CERTIFIED DOCUMENT.

09/19/2025



G16696  
C-1.12

ST. MARTINS, COLE COUNTY, MISSOURI



Missouri Engineering Corp. # 2004005018

2B - SHEET  
09/19/2025

KELLY A. LOHSANDT  
PROFESSIONAL ENGINEER  
PE-2021032813



Gravel A		
Station	4" Gravel A	Remarks
	(S.Y)	
O'Rourke Street		
2+52.13 LT.	13.0	
7+22.50	18.0	
Subtotal	31.0	
Total	311.0	

IF ORIGINAL SIGNATURE OR DIGITAL AUTHENTICATION IS NOT PRESENT THIS MEDIA SHOULD NOT BE CONSIDERED A CERTIFIED DOCUMENT.

09/19/2025



G16696  
C-1.13

ST. MARTINS, COLE COUNTY, MISSOURI



2B - SHEET  
09/19/2025

Missouri Engineering Corp. # 2004005018

KELLY A. LOHSANDT  
PROFESSIONAL ENGINEER  
PE-2021032813

BITUMINOUS PAVEMENT MIXTURE PG 64-22 (BP-1)						ESTIMATE FACTOR = 1.987 TONS/CY	
LOCATION	LOG MI. TO LOG MI.	LENGTH (MI)	LENGTH (FT)	WIDTH (FT)	THICKNESS (IN)	TOTAL (TONS)	
<b>HENWICK LN</b>							
MAIN LINE	0.000	0.966	5,101.8	22	1.5	1,032.5	
RTE T APPROACH			3,220 SF		1.5	29.6	
<b>SUBTOTAL</b>						1,062.1	
<b>5% FOR IRREGULARITIES</b>						53.1	
<b>TOTAL</b>						<b>1,115.2</b>	
<b>HOMESTEAD AVE</b>							
MAIN LINE	0.005	0.214	1,105.0	28	1.5	284.6	
HENWICK LN APPROACH			1,040 SF		1.5	9.6	
<b>SUBTOTAL</b>						294.2	
<b>5% FOR IRREGULARITIES</b>						14.7	
<b>TOTAL</b>						<b>308.9</b>	

MODIFIED COLD MILLING (DEPTH TRANSITIONS)				
LOCATION	LENGTH (FT)	WIDTH (FT)	DEPTH (IN)	TOTAL (SY)
<b>HENWICK LN</b>				
RTE T APPROACH	10	110	0 to 1.5	122
<b>TOTAL</b>				<b>122</b>
<b>HOMESTEAD AVE</b>				
ST MARTIN CITY LIMITS (CONCRETE)	50	28	0 to 1.5	156
<b>TOTAL</b>				<b>156</b>

BUTT JOINT FOR DRIVEWAYS				
LOCATION	LENGTH (FT)	WIDTH (FT)	DEPTH (IN)	TOTAL (SY)
<b>HENWICK LN</b>				
7423 DRIVEWAY	22	2	1.5 to 0	5
7412 DRIVEWAY	23	3	1.5 to 0	8
7312 DRIVEWAY	28	2	1.5 to 0	6
7304 DRIVEWAY	23	2	1.5 to 0	5
7220 DRIVEWAY (WEST)	32	2	1.5 to 0	7
7220 DRIVEWAY (EAST)	32	2	1.5 to 0	7
7214 DRIVEWAY	27	6	1.5 to 0	18
7119 DRIVEWAY	22	2	1.5 to 0	5
409 HOMESTEAD AVE DRIVEWAY	20	2	1.5 to 0	4
6929 DRIVEWAY	20	2	1.5 to 0	4
6928 DRIVEWAY	20	2	1.5 to 0	4
<b>TOTAL</b>				<b>73</b>
<b>HOMESTEAD AVE</b>				
409 DRIVEWAY	26	5	1.5 to 0	14
403 DRIVEWAY (NORTH)	30	6	1.5 to 0	20
403 DRIVEWAY (SOUTH)	33	6	1.5 to 0	22
306 DRIVEWAY (NORTH)	22	5	1.5 to 0	12
306 DRIVEWAY (SOUTH)	32	5	1.5 to 0	18
301 DRIVEWAY	22	4	1.5 to 0	10
<b>TOTAL</b>				<b>96</b>

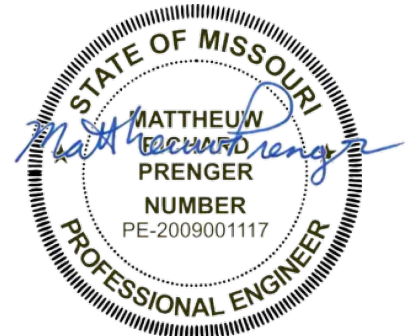

10-15-25

4" SOLID YELLOW WATERBORNE PAINT		
LOCATION	LENGTH (FT)	TOTAL (SY)
<b>HENWICK LN</b>		
MAINLINE - DOUBLE STRIPE	5130	10,260
<b>TOTAL</b>		<b>10,260</b>

C-1.14  
2B SHEET

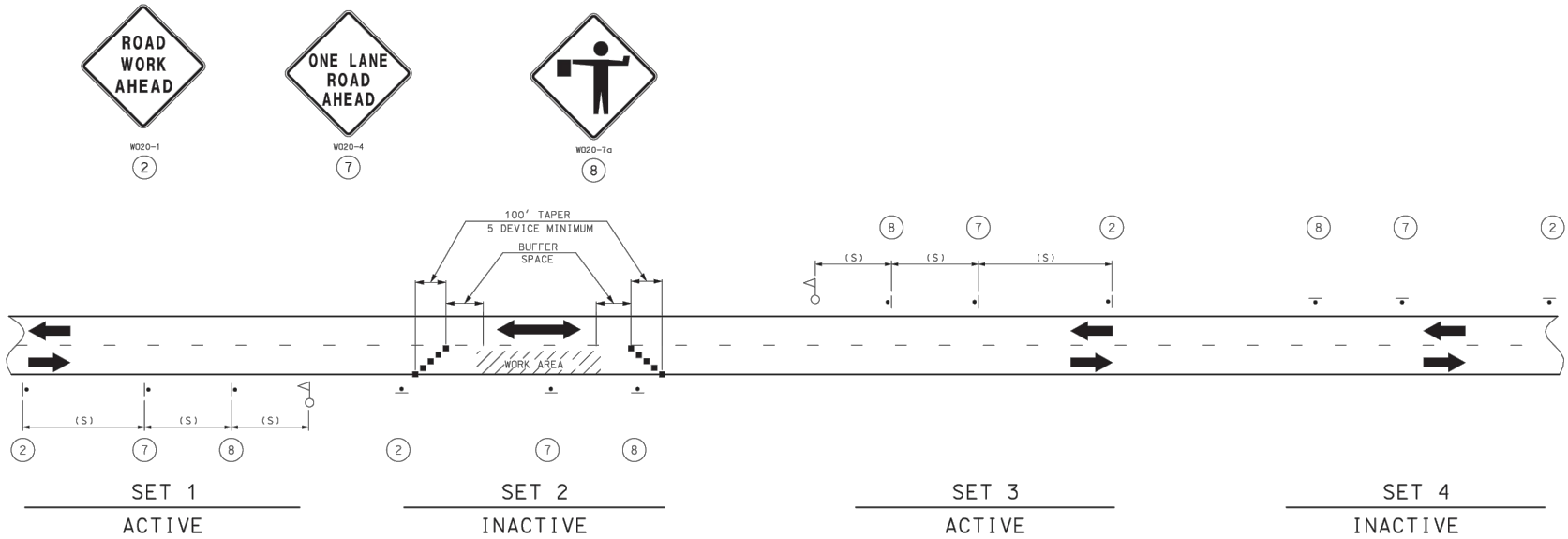

NOTES:

THIS PLAN IS FOR DAYLIGHT FLAGGING OPERATIONS ONLY. WHEN NIGHT WORK IS REQUIRED, OR OTHERWISE ALLOWED BY THE ENGINEER, WORK ZONE LIGHTING SHALL BE PROVIDED IN ACCORDANCE WITH SEC 616.5.2.

CHANNELIZING DEVICES LOCATED DOWNSTREAM OF THE ONE-LANE, TWO-WAY TAPER ARE OPTIONAL. THESE DEVICES SHOULD BE ELIMINATED WHEN THEIR USE WILL REDUCE THE USABLE LANE WIDTH, INCLUDING ANY ACCEPTABLE SHOULDERS, TO LESS THAN 10' OR WILL SIGNIFICANTLY AFFECT THE RESURFACING OPERATION.

SIGN SETS 1 AND 3 ARE ACTIVE AND (I.E., SIGNS FACE ONCOMING TRAFFIC) SIGN SETS 2 AND 4 ARE INACTIVE (I.E., SIGNS DO NOT FACE EITHER DIRECTION OF TRAFFIC) WHEN THE RESURFACING OPERATION IS LOCATED BETWEEN SIGN SETS 1 AND 3.

WHEN SIGN SETS 2 AND 4 ARE ACTIVE, SIGN SETS 1 AND 3 BECOME INACTIVE AND ARE ADVANCED TO BECOME SETS 2 AND 4 WITH SIGN LEGENDS TURNED AWAY FROM BOTH DIRECTIONS OF TRAFFIC. WHEN THE RESURFACING OPERATION ADVANCES TO BETWEEN SIGN SETS 2 AND 4, SIGN SETS 2 AND 4 BECOME ACTIVE (I.E., NEW SIGN SETS 1 AND 3) AND SIGN SETS 1 AND 3 ADVANCED IN THE DIRECTION OF THE OPERATION (I.E., NEW SIGN SETS 2 AND 4).

■ - CHANNELIZERS

○ - FLAGGER

SPEED	SIGN SPACING (FT) (1)	
	NON-DIVIDED HIGHWAYS (S)	BUFFER SPACE
PERMANENT POSTED (MPH)		LENGTH (FT)
0-35	200	250
40-45	350	360
50-55	500	495
60-70	1000	730

(1) SPACING BETWEEN SIGNS, BETWEEN LAST SIGN AND FLAGGER, BEGINNING OF TAPER OR SIGNED CONDITION.

SPACING MAY BE ADJUSTED AS NECESSARY TO MEET FIELD CONDITIONS.

IF ORIGINAL SIGNATURE OR DIGITAL AUTHENTICATION IS NOT PRESENT THIS MEDIA SHOULD NOT BE CONSIDERED A CERTIFIED DOCUMENT.

09/19/2025



G16696  
C-2.01

ST. MARTINS, COLE COUNTY, MISSOURI



09/19/2025

TEMPORARY TRAFFIC CONTROL

Missouri Engineering Corp. # 2004005018

KELLY A. LOHSANDT  
PROFESSIONAL ENGINEER  
PE-2021032813