

STP-5438 (613)

City of Clayton
10 N. Bemiston, Clayton, MO 63105

REQUEST FOR BID

BID OF

MoDOT Vendor Number (if required) _____

Bidder Name _____

Bidder Address _____

FOR
IMPROVING

Clayton CBD Resurfacing – Phase 1

**Clayton, MO
St. Louis County**

**INVITATION TO BID
ROADWAY RESURFACING PROJECT**

Notice to Contractors

Sealed bids for the Clayton CBD Resurfacing – Phase 1 STP-5438(613) Project will be received by the City of Clayton, Finance Department, 10 N. Bemiston Avenue, Clayton, MO 63105, until 1:30 PM, on October 26, 2023. Bids will be publicly opened and read aloud at 2:00 PM in the Police Department Courtroom at 10 N. Bemiston Avenue, Clayton, MO 63105.

The Scope of Work consists of a variable depth removal of the existing asphalt surface in order to correct the crown in the roadway, followed by replacement with a new 2” asphalt overlay for approximately 0.77 miles of roadway and the addition of concrete paver crosswalks. Replacement of underlying concrete slabs may be necessary in isolated locations as conditions require. Existing curb ramps will be replaced in order to bring them into ADA compliance and select signal components will require modification. Striping, traffic control and other items shall be included as shown in the specifications.

Bid packages will be available September 28, 2023 for view and download by visiting www.claytonmo.gov/vendors. A bid security in the amount of five percent (5%) of the bid amount must accompany each bid in accordance with the Bidders Checklist.

A pre-bid meeting will be held on October 12, 2023 at 10:00 AM in the Police Department Courtroom at 10 N. Bemiston Avenue, Clayton, MO 63105. **Attendance is strongly encouraged for bidders.**

All labor used in the construction of this public improvement shall be paid a wage no less than the prevailing hourly rate of wages of work of a similar character in this locality as established by the Department of Labor and Industrial Relations (Federal Wage Rate), or state wage rate, whichever is higher.

The City of Clayton hereby notifies all bidders that it will affirmatively ensure that in any contract entered into pursuant to this advertisement, businesses owned and controlled by socially and economically disadvantaged individuals will be afforded full opportunity to submit bids in response to this invitation and will not be discriminated against on the grounds of race, color, religion, creed, sex, age, ancestry, or national origin in consideration for an award.”

All bidders must be on MoDOT’s Qualified Contractor List per Section 102.2 of the Missouri Standard Specifications for Highway Construction, 2023 Edition (<https://www.modot.org/missouri-standard-specifications-highway-construction>) including all revisions. The contractor questionnaire must be on file 7 days prior to bid opening.

Contractors and sub-contractors who sign a contract to work on public works project provide a 10-Hour OSHA construction safety program, or similar program approved by the Department of Labor and Industrial Relations, to be completed by their on-site employees within sixty (60) days of beginning work on the construction project.

The City of Clayton reserves the right to accept or reject any bid and the waive any irregularities in the best interest of the City.

The DBE goal for this project is 12%

No 2nd tier subcontracting will be allowed on this project.

BIDDER CHECKLIST
FINAL CHECKLIST BEFORE SUBMITTING BID

- 1. Submit completed Contractor Questionnaire and/or Contractor Prequalification Questionnaire with attachments not later than seven (7) days prior to the date and hour of the bid opening. See Secs 101-103 of the Standard Specifications, and Rule 7 CSR 10-15.900, "Prequalifications to Bid of Certain Contractors". Questionnaire and Contact information are provided on MoDOT’s website.
- 2. For submittal of paper bids, the complete set of bidding documents includes all information through the DBE forms (for DBE forms see #7). The Technical Specifications/Job Special Provisions are for the bidder’s information only and is not to be returned with the bid.
- 3. If submitting the bid by mail, it is to be completed, executed, and submitted in a sealed envelope addressed to Matt Malick, City of Clayton, 10 N. Bemiston Ave., Clayton, MO 63105. Envelopes shall be sealed and labeled "SEALED BID ENCLOSED" on the face thereof and display the project name “Clayton CBD Resurfacing – Phase 1”.
- 4. Please read all items in the bidding document carefully. For paper bids, complete all items in ink or by typing in the information.
- 5. Sign this bidding document properly. If submitted in the name of a firm or corporation, the legal name of the firm or corporation should appear in the space designated, and be signed for by one or more persons legally qualified to execute papers in the name of said firm or corporation. Affix Corporate Seal if the Bidder is a Corporation.
- 6. For paper bids submit a bid bond executed by bidder and surety, or attach cashier's check to the bid bond form.
- 7. Submit the DBE Submittal Forms within 3 business days of the Bid Opening. The BDE Identification Submittal Form (Page 2 of this document) must be submitted for each DBE to be utilized on the project.
- 8. For paper bids, staple addenda to the bid in the appropriate part of the bid. The letter accompanying the addenda should be stapled to the inside of the back cover of the bid and returned. The bidder should retain a duplicate copy.

.....

Below is a list of common mistakes made by bidders leading to non-responsive bids. Please refer to the Standard Specifications for the appropriate procedures for completing and submitting a bid.

- a) Not signing the bid
- b) Not incorporating the addendum into the bidding documents, including attaching the letter to the bid
- c) Not providing a bid bond
- d) Using pencil to fill out the bid
- e) Using white out to make corrections to the itemized bid sheets
- f) Not initialing changes made

.....

All questions concerning the bid document preparation can be directed to Matt Malick, Director of Public Works, at 314-290-8547. Project specific questions can be directed to Brady Jordan, Principal Engineer, Horner & Shifrin at 314-335-8661.

Special Needs: If you have special needs addressed by the Americans with Disabilities Act, please notify Matt Malick, Director of Public Works, at 314-290-8547 or through Missouri Relay System, TDD 1-800-735-2966, at least five (5) working days prior to the bid opening.

TABLE OF CONTENTS

Notice to Contractors

- Proposed Work..... (1)
- Compliance With Contract Provisions..... (2)
- Period of Performance (3)
- Liquidated Damages (4)
- Bid Guaranty..... (5)
- Certifications for Federal Jobs (6)
- Antidiscrimination (7)
- Federal and State Inspection (8)
- Prevailing Wage..... (9)
- Worker Eligibility Requirements (10)
- OSHA Training Requirements..... (11)
- Buy America Requirements (12)
- Addendum Acknowledgement..... (13)
- Signature and Identity of Bidder..... (14)
- Trainees..... (15)
- Subcontractor Disclosure (16)
- Project Award (17)
- Materials Inspections..... (18)
- Prime Contractor Requirements (19)
- Tax Exempt Status (20)
- Acceptance for Provision for Asphalt Cement Price Index..... (21b)

Itemized Bid Sheets

- Bid Bond
- DBE Identification Submittal
- DBE Provisions
- General Provisions (Other Than MoDOT)
- Job Special Provisions
- Form FHWA 1273
- Federal Aid Provisions
- Applicable State Wage Rates
- Applicable Federal Wage Rates
- Applicable Environmental and Cultural Permits and Clearances
- ADA Checklist
- Contract Forms

NOTICE TO CONTRACTORS

Sealed bids for the Clayton CBD Resurfacing – Phase 1 STP-5438(613) Project will be received by the City of Clayton, Finance Department, 10 N. Bemiston Avenue, Clayton, MO 63105, until 1:30 PM, on October 26, 2023. Bids will be publicly opened and read aloud at 2:00 PM in the Police Department Courtroom at 10 N. Bemiston Avenue, Clayton, MO 63105.

(1) **PROPOSED WORK:** The proposed work, hereinafter called the work, includes:

A variable depth removal of the existing asphalt surface in order to correct the crown in the roadway, followed by replacement with a new 2” asphalt overlay for approximately 0.77 miles of roadway and the addition of concrete paver crosswalks. Replacement of underlying concrete slabs may be necessary in isolated locations as conditions require. Existing curb ramps will be replaced in order to bring them into ADA compliance and select signal components will require modification. Striping, traffic control, and other items shall be included as shown in the specifications.

(2) **COMPLIANCE WITH CONTRACT PROVISIONS:** The bidder, having examined and being familiar with the local conditions affecting the work, and with the contract, contract documents, including the 2023 version of the Missouri Highways and Transportation Commission's "Missouri Standard Specifications for Highway Construction," and "Missouri Standard Plans for Highway Construction", their revisions, and the request for bid, including appendices, the special provisions and plans, hereby proposes to furnish all labor, materials, equipment, services, etc., required for the performance and completion of the work. All references are to the Missouri Standard Specifications for Highway Construction, as revised, unless otherwise noted.

The following documents are available on the Missouri Department of Transportation web page at www.modot.mo.gov under "Business with MoDOT" "Standards and Specifications". The effective version shall be determined by the letting date of the project.

General Provisions & Supplemental Specifications

Supplemental Revisions to Missouri Standard Plans
For Highway Construction (if applicable)

These supplemental bidding documents contain all current revisions to the bound printed versions and have important legal consequences. It shall be conclusively presumed that they are in the bidder's possession, and they have been reviewed and used by the bidder in the preparation of any bid submitted on this project.

- St. Louis County Highway Standard Specifications for Road and Bridge Construction (2022 edition)
- Metropolitan St. Louis Sewer District Standard Construction Details and Specification (2009 edition)

Please note that within the above-listed documents, the term “Commission” shall be replaced with the term, City of Clayton, and the term “Engineer” is a reference to the Engineer of Record from Horner & Shifrin.

The contracting authority for this contract is the City of Clayton.

(3) **PERIOD OF PERFORMANCE:** If the bid is accepted, the bidder agrees that work shall be diligently prosecuted at such rate and in such manner as, in the judgment of the engineer, is necessary for the completion of the work within the time specified as follows in accordance with Sec 108:

Calendar Days: 365 days

(4) **LIQUIDATED DAMAGES:** The bidder agrees that, should the bidder fail to complete the work in the time specified or such additional time as may be allowed by the engineer under the contract, the amount of liquidated

damages to be recovered in accordance with Sec 108 shall be as follows:

Liquidated damages per day \$ 1,100

Schedule of Deductions for Each Day of Overrun in Contract Time, Original Contract Amount (or the Engineer's Estimate of the Total Construction Cost)		
From (\$)	To, and including (\$)	Assessment, per Day (\$)
0	25,000	475
25,001	50,000	475
50,001	100,000	500
100,001	500,000	700
500,001	1,000,000	950
1,000,001	2,000,000	1,100
2,000,001	3,000,000	1,225
3,000,001	4,000,000	1,625
4,000,001	5,000,000	2,025
5,000,001	6,000,000	2,425
6,000,001	7,000,000	2,825
7,000,001	8,000,000	3,225
8,000,001	9,000,000	3,625
9,000,001	10,000,000	4,025
10,000,001	70,000,000	4,300

(5) **BID GUARANTY:** The bidder shall submit a Bid Guaranty of at least 5% of the bid amount. Bid bond requirements expressed as a dollar amount are not allowed. The bid guaranty can be in the form of a cashier's check, certified check or bid bond. Bid bonds must be guaranteed by a surety company authorized by the director of the department of insurance, financial institutions and professional registration to conduct surety business in the state of Missouri. A sample project bid bond form is included in the bid book. The bidder shall mark the box below to identify the type of Bid Guaranty. If the bidder fails to enter into a contract with the City on the terms stated in his bid, or fails to furnish a performance bond as required by the Contract Documents, the amount of the Bid Guaranty shall be forfeited to the City as liquidated damages, not as a penalty. The City will have the right to retain the Bid Guaranty of bidders to whom an award is being considered until either (a) the City-Contractor Agreement has been executed and the performance bond has been furnished, (b) the specified time has elapsed so that bids may be withdrawn, or (c) all bids have been rejected. The Bid Guaranty of all bidders to whom an award is not being considered shall be returned promptly after the bid opening.

- Paper Bid Bond
- Cashier's Check

(6) **CERTIFICATIONS FOR FEDERAL JOBS:** By signing and submitting this bid, the bidder makes the certifications appearing in Sec. 102.18.1 (regarding affirmative action and equal opportunity), Sec. 102.18.2 (regarding disbarment, eligibility, indictments, convictions, or civil judgments), Sec. 102.18.3 (regarding anti-collusion), and Sec. 102.18.4 (regarding lobbying activities). Any necessary documentation is to accompany the bid submission, as required

by these sections. As provided in Sec. 108.13, the contracting authority may terminate the contract for acts of misconduct, which includes but is not limited to fraud, dishonesty, and material misrepresentation or omission of fact within the bid submission.

(7) **ANTIDISCRIMINATION:** The Contracting Authority hereby notifies all bidders that it will affirmatively insure that in any contract entered into pursuant to this advertisement, businesses owned and controlled by socially and economically disadvantaged individuals will be afforded full opportunity to submit bids in response to this invitation and will not be discriminated against on the grounds of race, color, religion, creed, sex, age, ancestry, or national origin in consideration for an award.

(8) **FEDERAL AND STATE INSPECTION:** The Federal Government is participating in the cost of construction of this project. All applicable Federal laws, and the regulations made pursuant to such laws, shall be observed by the contractor, and the work will be subject to the inspection of the appropriate State or Federal Agency in the same manner as provided in Sec 105.10 of the Missouri Standard Specifications for Highway Construction with all revisions applicable to this bid and contract.

(9) **PREVAILING WAGE (FEDERAL AND STATE):** This contract requires payment of the prevailing hourly rate of wages for each craft or type of work required to execute the contract as determined by the Missouri Department of Labor and Industrial Relations, and requires adherence to a schedule of minimum wages as determined by the United States Department of Labor. For work performed anywhere on this project, the contractor and the contractor's subcontractors shall pay the higher of these two applicable wage rates. The applicable state wage rates for this contract are detailed in "Annual Wage Order No. 29", that is attached to this bidding document. The applicable federal wage rates for this contract are the effective Davis-Bacon federal wage rates posted the tenth day before the bid opening date and are attached herein.

These supplemental bidding documents have important legal consequences. It shall be conclusively presumed that they are in the bidder's possession, and they have been reviewed and used by the bidder in the preparation of any bid submitted on this project.

(10) **WORKER ELIGIBILITY REQUIREMENTS:** Execution of the construction contract for this project is dependent upon the awarded bidder providing an Affidavit of Compliance AND E-Verify Memorandum-of-Understanding (MOU) between the bidder and Department of Homeland Security to the Contracting Authority as required by section 285.530 RSMo. The cover page and signature page of the E-Verify MOU and the Affidavit must be submitted prior to award of this contract.

A sample Affidavit of Compliance can be found at the Missouri Attorney General's website at the following link:

http://ago.mo.gov/forms/Affidavit_of_Compliance.pdf

All bidders must also be enrolled in the E-Verify Program, and include their MOU prior to contract execution. Bidders who are not enrolled will need to go to the following website link and select "Enroll in the Program" to get started. After completing the program, they will receive their E-Verify MOU with Department of Homeland Security. This document will need to be printed out and kept on file so that a copy can be attached to the Affidavit of Compliance.

http://www.dhs.gov/files/programs/gc_1185221678150.shtm

This requirement also applies to subcontractors and contract labor, but this contract only requires submittal of the verification documents for the prime contractor. It is the prime contractor's responsibility to verify the worker eligibility of their subcontractors in order to protect their own company from liability as required by section 285.530 RSMo.

(11) **OSHA TEN HOUR TRAINING REQUIREMENTS:** Missouri Law, 292.675 RSMO, requires any awarded contractor and its subcontractor(s) to provide a ten-hour Occupational Safety and Health Administration (OSHA) Construction Safety Program (or a similar program approved by the Missouri Department of Labor and Industrial Relations as a qualified substitute) for their on-site employees (laborers, workmen, drivers, equipment operators, and craftsmen) who have not previously completed such a program and are directly engaged in actual construction of the improvement (or working at a nearby or adjacent facility used for construction of the improvement). The awarded contractor and its subcontractor(s) shall require all such employees to complete this ten-hour program, pursuant to 292.675 RSMO, unless they hold documentation on their prior completion of said program. Penalties, for Non-Compliance include contractor

forfeiture to the Contracting Authority in the amount of \$2,500, plus \$100 per contractor and subcontractor employee for each calendar day such employee is employed beyond the elapsed time period for required program completion under 292.675 RSMO.

(12) BUY AMERICA REQUIREMENTS: Construction contracts shall assure compliance with Section 165 of the Surface Transportation Assistance Act of 1982, Section 337 of the Surface Transportation and Uniform Relocation Assistance Act of 1987, 23 CFR 635.410, and the Bipartisan Infrastructure Law (2021) Build America, Buy America Act Publication L. No. 117-58 regarding Buy America provisions on the procurement of foreign products and materials. On all contracts involving Federal-aid, all products of iron, steel, or a coating of steel which are incorporated into the work must have been manufactured in the United States. Construction materials consisting primarily of non-ferrous metals, plastic and polymer-based products, glass, lumber, or drywall also require Buy America certification. Cement and cementitious materials; aggregates such as stone, sand, or gravel; or aggregate binding agents or additives are excluded from this requirement. In addition, manufactured products are currently exempted under the 1983 waiver from FHWA. The Contracting Authority may allow minimal amounts of these materials from foreign sources, provided the cost does not exceed 0.1 percent of the contract sum or \$2,500, whichever is greater. The Contractor certifies that these materials are of domestic origin. Additional information regarding the “Buy America” requirements can be found at:

<https://www.fhwa.dot.gov/construction/cqit/buyam.cfm>

(13) ADDENDUM ACKNOWLEDGEMENT: The undersigned states that the all addenda (if applicable) have been received, acknowledged and incorporated into their bid, prior to submittal. For paper bids, staple addenda to the bid in the appropriate part of the bid.

(14) SIGNATURE AND IDENTITY OF BIDDER: The undersigned states that the following provided information is correct and that (if not signing with the intention to bind themselves to become the responsible and sole bidder) they are the agent of, and they are signing and executing this, as the bid of

_____, which is the correct LEGAL NAME as stated on the contractor questionnaire.

a) The organization submitting this bid is a(n) (1) individual bidder, (2) partnership, (3) joint venturer (whether individuals or corporations, and whether doing business under a fictitious name), or (4) corporation. Indicate by marking the appropriate box below.

- sole individual partnership joint venture
- corporation, incorporated under laws of state of _____.

b) If the bidder is doing business under a fictitious name, indicate below by filling in the fictitious name

Executed by bidder this _____ day of _____ 20____.

THE BIDDER CERTIFIES THAT THE BIDDER AND ITS OFFICIALS, AGENTS, AND EMPLOYEES HAVE NEITHER DIRECTLY NOR INDIRECTLY ENTERED INTO ANY AGREEMENT, PARTICIPATED IN ANY COLLUSION, OR OTHERWISE TAKEN ANY ACTION IN RESTRAINT OF FREE COMPETITIVE BIDDING IN CONNECTION WITH THIS BID, AND THAT THE BIDDER INTENDS TO PERFORM THE WORK WITH ITS OWN BONAFIDE EMPLOYEES AND SUBCONTRACTORS, AND DID NOT BID FOR THE BENEFIT OF ANOTHER CONTRACTOR.

THE BIDDER ACKNOWLEDGES THAT THIS IS AN UNSWORN DECLARATION, EXECUTED UNDER PENALTY OF PERJURY UNDER THE LAWS OF THE UNITED STATES AND/OR FALSE DECLARATION UNDER THE LAWS OF MISSOURI, AND ANY OTHER APPLICABLE STATE OR FEDERAL LAWS. THE FAILURE TO PROVIDE THIS CERTIFICATION IN THIS BID MAY MAKE THIS BID NON-RESPONSIVE, AND CAUSE IT TO BE REJECTED.

THE BIDDER CERTIFIES THAT THE BIDDER'S COMPANY KNOWINGLY EMPLOYS ONLY INDIVIDUALS WHO ARE AUTHORIZED TO WORK IN THE UNITED STATES IN ACCORDANCE WITH APPLICABLE FEDERAL AND STATE LAWS AND ALL PROVISIONS OF MISSOURI EXECUTIVE ORDER NO. 07-13 FOR CONTRACTS WITH THE CONTRACTING AUTHORITY.

- Check this box ONLY if the bidder REFUSES to make any or all of these certifications. The bidder may provide an explanation for the refusal(s) with this submittal.

Signature of Bidder's Owner, Officer, Partner or Authorized Agent

Please print or type name and title of person signing here

Attest:

Secretary of Corporation if Bidder is a Corporation

Affix Corporate Seal (If Bidder is a Corporation)

NOTE: If bidder is doing business under a fictitious name, the bid shall be executed in the legal name of the individual, partners, joint ventures, or corporation, and registration of fictitious name filed with the secretary of state, as required by sections 417.200 to 417.230 RSMo. If the bidder is a corporation not organized under the laws of Missouri, it shall procure a certificate of authority to do business in Missouri, as required by section 351.572 et seq RSMo. A certified copy of such registration of fictitious name or certificate of authority to do business in Missouri shall be filed with the Missouri Highways and Transportation Commission, as required by the standard specifications.

(15) **TRAINEES:** By submitting this bid, the bidder certifies that the bidder is familiar with the Training Provision in the Missouri Highways and Transportation Commission's "General Provisions and Supplement Specifications" which are available on the Missouri Department of Transportation web page at www.modot.mo.gov under "Business with MoDOT" "Standards and Specifications". The number of trainee hours provided under this contract will be 0 slots at 1000 hours per slot or 0 hours.

(16) **SUBCONTRACTOR DISCLOSURE:** Requirements contained within Sec 102.7.8 of the Missouri Standard Specification for Highway Construction shall be waived for this contract.

(17) **PROJECT AWARD:** This project will be awarded to the lowest, responsive, responsible bidder.

(18) **MATERIALS INSPECTIONS:** All technicians who perform, or are required by the FHWA to witness, such sampling and testing shall be deemed as qualified by virtue of successfully completing the requirements of EPG 106.18 Technician Certification Program, for that specific technical area.

(19) **PRIME CONTRACTOR REQUIREMENTS:** The limitation in Sec 108.1.1 of the Missouri Standard Specifications for Highway Construction that "the contractor's organization shall perform work amounting to not less than 40 percent of the total contract cost" is waived for this contract. Instead, the less restrictive terms of the Federal Highway Administration's rule at Title 23 Code of Federal Regulations (CFR) § 635.116(a) shall apply, so that the contractor must perform project work with its own organization equal to and not less than 30 percent of the total original contract price. Second-tier subcontracting will not be permitted on this contract. All other provisions in Sec 108.1.1 et seq. of the Missouri Standard Specifications for Highway Construction shall remain in full force and effect, and shall continue to govern the contractor and its subcontractors, in accordance with the provisions of Title 23 CFR § 635.116.

(20) **SALES AND USE TAX EXEMPTION:** The City of Clayton, a tax exempt entity, will furnish a Missouri Project Exemption Certificate as described in Section 144.062 RSMo to the awarded contractor who in turn may use the certificate to purchase materials for a specific project performed for the tax exempt entity. Only the materials and supplies incorporated or consumed during the construction of the project are exempt. The certificate will be issued to the contractor for a specific project for a defined period of time.

(21) **(b) ACCEPTANCE FOR PROVISION FOR ASPHALT CEMENT PRICE INDEX, SEAL COAT PRICE INDEX, UNDERSEAL PRICE INDEX OR UBAWS MEMBRANE PRICE INDEX:** Bidders have the option to accept the provision for Asphalt Cement Price Index, Seal Coat Price Index, Underseal Price Index and/or UBAWS Membrane Price Index in accordance with the General Provisions. The bidder must mark each box below if they choose to accept the provision. The Asphalt Cement Provision applies only to projects that have a quantity of asphalt wet ton mix pay items or converted square yard quantity over 1,000 tons, the Seal Coat Provision applies only to projects that have a quantity that exceeds 50,000 square yards, the Underseal Provision applies only to any projects that have a quantity that exceeds 10,000 gallons, and the UBAWS Membrane provision applies only to projects that have a quantity that exceeds 5,000 square yards. The above quantity limits apply to an individual project or any number of projects in the contract combination.

Asphalt Cement Seal Coat Underseal UBAWS Membrane

ITEMIZED BID: The bidder should complete the following section in accordance with Sec 102.7. The bidder proposes to furnish all labor, materials, equipment, services, etc. required for the performance and completion of the work, as follows:

ITEMIZED BID: The bidder should complete the following section in accordance with Sec 102.7. The bidder proposes to furnish all labor, materials, equipment, services, etc. required for the performance and completion of the work, as follows:

CENTRAL BUSINESS DISTRICT RESURFACING PROJECT - PHASE 1						
PROJECT NO: STP-5438(613)						
BID FORM						
LINE NO.	ITEM NUMBER	ITEM DESCRIPTION	UNIT	QUANTITY	UNIT PRICE	TOTAL
ROADWAY ITEMS:						
1	JSP - G	REMOVAL OF IMPROVEMENTS	L.S.	1		
2	404-12.71	SUPERPAVE ASPHALTIC CONCRETE MIXTURE SP125 (PG 70-22) CLP	TON	2774.9		
3	JSP - N	HIGH TENSILE STRENGTH SYNTHETIC FIBERS FOR ASPHALT	LBS.	2775		
4	407-10.27	TACK-EMULSIFIED ASPHALT (SS-1H)	GAL.	2600		
5	412-10.04	PAVEMENT SURFACING AND TEXTURING (0" TO 4"), CONCRETE OR ASPHALT	S.Y.	25923		
6	JSP - FF	EMULSIFIED MALTENE-BASED REJUVENATOR	S.Y.	25923		
7	JSP - H	CONCRETE BASE (8", NON-REINFORCED)	S.Y.	1235		
8	JSP - I	ADJUST SERVICE VALVE BOX TO GRADE	EACH	9		
9	604-20.30	ADJUSTING MANHOLE TO GRADE	EACH	11		
10	604-52.99	CONNECTING PIPE TO EXISTING STRUCTURE	EACH	1		
11	604-90.50	REPLACE PRECAST INLET STONE AND ADJUST TO GRADE	EACH	1		
12	JSP - Q	VARIABLE HEIGHT TRENCH DRAIN SYSTEM	L.F.	43		
13	JSP - R	CONCRETE CURB AND GUTTER, TYPE A (8 IN.)	L.F.	670		
14	612-10.20	MOVEABLE BARRICADES WITH MODEL "B" AMBER FLASHERS (2 EACH PER BARRICADE)	EACH	20		
15	612-60.92	ARROW PANEL, TYPE "B" (NOISELESS), RENTAL	EACH	4		
16	612-70.00	CHANGEABLE MESSAGE BOARD (NOISELESS), RENTAL	EACH	2		
17	JSP - E	CONSTRUCTION SIGNS	S.F.	400		
18	JSP - E	CHANNELIZER (TRIM LINE)	EACH	300		
19	619-00.00	MOBILIZATION	L.S.	1		
20	726-58.12	8" POLYVINYL CHLORIDE PIPE	L.F.	69		
21	806-45.08	INLET PROTECTION DEVICE, SINGLE UNIT - FILTER SOCK/ROLL	EACH	6		
22	806-45.09	INLET PROTECTION DEVICE, DOUBLE UNIT - FILTER SOCK/ROLL	EACH	3		
23	806-45.15	INLET PROTECTION DEVICE, GRATED UNIT - FILTER SOCK/ROLL	EACH	6		
24	JSP - AA	EXISTING SENSYS PUCKS (T.B.R. & REPLACED WITH NEW)	EACH	9		
25	904-95.31	ADJUSTMENT OF PREFORMED PULL BOX	EACH	26		
26	904-95.40	ADJUSTMENT OF CONCRETE SINGLE PULL BOX	EACH	1		
BICYCLE FACILITIES:						
27	JSP - T	PAVEMENT MARKING, BICYCLE SHARED LANE SYMBOL	EACH	13		
28	JSP - S	ROADWAY SIGN - BIKES MAY USE FULL LANE (MUTCD R4-11)	EACH	6		

CENTRAL BUSINESS DISTRICT RESURFACING PROJECT - PHASE 1						
PROJECT NO: STP-5438(613)						
BID FORM CONTINUED						
LINE NO.	ITEM NUMBER	ITEM DESCRIPTION	UNIT	QUANTITY	UNIT PRICE	TOTAL
PEDESTRIAN FACILITIES:						
29	JSP - U	CONCRETE SIDEWALK (5" THICK)	S.Y.	524.2		
30	JSP - U	CONCRETE SIDEWALK, CURB RAMP (7" THICK)	S.Y.	163.6		
31	JSP - U	DETECTABLE WARNING SURFACE	S.F.	256.8		
32	JSP - X	BRICK PAVER CARRIAGE STRIP	S.F.	408.4		
PAVEMENT MARKING AND STRIPING:						
33	JSP - T	4 IN. WHITE HIGH BUILD WATERBORNE PAVEMENT MARKING PAINT, TYPE L BEADS	L.F.	5578		
34	JSP - T	4 IN. YELLOW HIGH BUILD WATERBORNE PAVEMENT MARKING PAINT, TYPE L BEADS	L.F.	7631		
35	JSP - T	12 IN. WHITE HIGH BUILD WATERBORNE PAVEMENT MARKING PAINT, TYPE L BEADS	L.F.	1518		
36	JSP - T	24 IN. WHITE HIGH BUILD WATERBORNE PAVEMENT MARKING PAINT, TYPE L BEADS	L.F.	428		
37	JSP - T	PAVEMENT MARKING, LEFT TURN ARROW	EACH	34		
38	JSP - T	PAVEMENT MARKING, RIGHT TURN ARROW	EACH	16		
39	JSP - T	PAVEMENT MARKING, THROUGH ARROW	EACH	5		
40	JSP - T	PAVEMENT MARKING, COMBINATION STRAIGHT LEFT	EACH	2		
41	JSP - T	PAVEMENT MARKING, COMBINATION STRAIGHT RIGHT	EACH	4		
42	JSP - T	PAVEMENT MARKING WORD "STOP"	EACH	5		
43	JSP - T	ACCESSIBLE PARKING SPACE PAVEMENT MARKING	EACH	6		
44	JSP - S	RESERVED PARKING SIGN (MUTCD R7-8)	EACH	2		
TRAFFIC SIGNAL ITEMS:						
45	902-52.00	CONDUIT, 2 IN., TRENCH	L.F.	25		
46	904-49.22	DETECTOR, PEDESTRIAN PUSH BUTTON, APS, FREEZEPROOF	EACH	2		
47	904-85.05	CABLE, DETECTOR LOOP, #14 GAUGE, 1 CONDUCTOR, W/TUBE JACKET (IN CONDUIT AND PULL BOX)	L.F.	34		
48	904-85.06	CABLE, DETECTOR LOOP, #14 GAUGE, 1 CONDUCTOR, W/TUBE JACKET (IN SAWED SLOT)	L.F.	368		
49	904-85.34	CABLE, COMMUNICATION, #18 GAUGE, 4 CONDUCTOR (APS)	L.F.	230		
50	904-95.10	OPENING DRILLED IN EXISTING CONCRETE PULL BOX	EACH	2		
51	JSP - Y	NEW STANCTION POST (INCLUDES BASE)	EACH	2		
NON-PARTICIPATORY ITEMS:						
52	JSP - V	BRICK PAVER CROSSWALK	S.F.	5910		
53	JSP - W	PCC BASE FOR CONCRETE PAVERS	L.F.	750		
TOTAL	BASE BID WRITTEN:				BASE BID NUMBERS:	

CENTRAL BUSINESS DISTRICT RESURFACING PROJECT - PHASE 1 PROJECT NO: STP-5438(613) BID FORM CONTINUED						
LINE NO.	ITEM NUMBER	ITEM DESCRIPTION	UNIT	QUANTITY	UNIT PRICE	TOTAL
		ADD ALTERNATE A:				
54	404-12.71	SUPERPAVE ASPHALTIC CONCRETE MIXTURE SP125 (PG 70-22) CLP	TON	27.9		
55	JSP - N	HIGH TENSILE STRENGTH SYNTHETIC FIBERS	LBS.	28		
56	407-10.27	TACK-EMULSIFIED ASPHALT (SS-1H)	GAL.	30		
57	412-10.04	PAVEMENT SURFACING AND TEXTURING (0" TO 4"), CONCRETE OR ASPHALT	S.Y.	260		
58	904-85.05	CABLE, DETECTOR LOOP, #14 GAUGE, 1 CONDUCTOR, W/TUBE JACKET (IN CONDUIT AND PULL BOX)	L.F.	159		
59	904-85.06	CABLE, DETECTOR LOOP, #14 GAUGE, 1 CONDUCTOR, W/TUBE JACKET (IN SAWED SLOT)	L.F.	712		
TOTAL	ADD ALTERNATE A WRITTEN:				ADD ALTERNATE A NUMBERS:	
TOTAL	BASE BID PLUS ADD ALTERNATE WRITTEN:				BASE BID PLUS ADD ALTERNATE A NUMBERS:	

BID BOND

KNOW ALL PERSONS BY THESE PRESENTS, that we _____
as principal and _____
as surety, are held and firmly bound unto the (Insert LPA Name) _____ in the penal sum
of _____ Dollars (\$) _____ to be paid to the commission to
be credited to the state road fund, the principal and surety binding themselves, their heirs, executors, administrators, successors,
and assigns, jointly and severally, firmly by these presents.

Sealed with our seals and dated this _____

THE CONDITION OF THIS OBLIGATION is such that

WHEREAS the principal is submitting herewith a bid to the commission on route(s)

in _____ County(ies),
project (s) _____

for construction or improvement of state highway as set out in said bid;

NOW THEREFORE, if the commission shall accept the bid of the principal and if the principal shall properly
execute and deliver to the commission the contract, contract bond, and evidence of insurance coverage in compliance with the
requirements of the bid, the specifications, and the provisions of section 227.100 RSMo, to the satisfaction of the commission,
then this obligation shall be void and of no effect, otherwise to remain in full force and effect.

In the event the said principal shall, in the judgment of the commission, fail to comply with any requirement as
set forth in the preceding paragraph, then the state of Missouri, acting by and through the commission, shall immediately and
forthwith be entitled to recover the full penal sum above set out, together with court costs, attorney's fees, and any other expense
of recovery.

The principal and surety hereby certify that the document is the original or a verbatim copy of the bid bond form
furnished by the Commission, in accordance with Sec 102.9 of the Missouri Standard Specifications for Highway Construction.

NOTE: This bond must be executed by the principal, and by a corporate surety authorized to conduct surety business in the
state of Missouri.

SEAL By _____
Principal
Signature

SEAL By _____
Surety
Signature of Attorney in Fact

ITEMIZED BID: The bidder should complete the following section in accordance with Sec 102.7. The bidder proposes to furnish all labor, materials, equipment, services, etc. required for the performance and completion of the work, as follows:

CENTRAL BUSINESS DISTRICT RESURFACING PROJECT - PHASE 1						
PROJECT NO: STP-5438(613)						
BID FORM						
LINE NO.	ITEM NUMBER	ITEM DESCRIPTION	UNIT	QUANTITY	UNIT PRICE	TOTAL
ROADWAY ITEMS:						
1	JSP - G	REMOVAL OF IMPROVEMENTS	L.S.	1		
2	404-12.71	SUPERPAVE ASPHALTIC CONCRETE MIXTURE SP125 (PG 70-22) CLP	TON	2774.9		
3	JSP - N	HIGH TENSILE STRENGTH SYNTHETIC FIBERS FOR ASPHALT	LBS.	2775		
4	407-10.27	TACK-EMULSIFIED ASPHALT (SS-1H)	GAL.	2600		
5	412-10.04	PAVEMENT SURFACING AND TEXTURING (0" TO 4"), CONCRETE OR ASPHALT	S.Y.	25923		
6	JSP - FF	EMULSIFIED MALTENE-BASED REJUVENATOR	S.Y.	25923		
7	JSP - H	CONCRETE BASE (8", NON-REINFORCED)	S.Y.	1235		
8	JSP - I	ADJUST SERVICE VALVE BOX TO GRADE	EACH	9		
9	604-20.30	ADJUSTING MANHOLE TO GRADE	EACH	11		
10	604-52.99	CONNECTING PIPE TO EXISTING STRUCTURE	EACH	1		
11	604-90.50	REPLACE PRECAST INLET STONE AND ADJUST TO GRADE	EACH	1		
12	JSP - Q	VARIABLE HEIGHT TRENCH DRAIN SYSTEM	L.F.	43		
13	JSP - R	CONCRETE CURB AND GUTTER, TYPE A (8 IN.)	L.F.	670		
14	612-10.20	MOVEABLE BARRICADES WITH MODEL "B" AMBER FLASHERS (2 EACH PER BARRICADE)	EACH	20		
15	612-60.92	ARROW PANEL, TYPE "B" (NOISELESS), RENTAL	EACH	4		
16	612-70.00	CHANGEABLE MESSAGE BOARD (NOISELESS), RENTAL	EACH	2		
17	JSP - E	CONSTRUCTION SIGNS	S.F.	400		
18	JSP - E	CHANNELIZER (TRIM LINE)	EACH	300		
19	619-00.00	MOBILIZATION	L.S.	1		
20	726-58.12	8" POLYVINYL CHLORIDE PIPE	L.F.	69		
21	806-45.08	INLET PROTECTION DEVICE, SINGLE UNIT - FILTER SOCK/ROLL	EACH	6		
22	806-45.09	INLET PROTECTION DEVICE, DOUBLE UNIT - FILTER SOCK/ROLL	EACH	3		
23	806-45.15	INLET PROTECTION DEVICE, GRATED UNIT - FILTER SOCK/ROLL	EACH	6		
24	JSP - AA	EXISTING SENSYS PUCKS (T.B.R. & REPLACED WITH NEW)	EACH	9		
25	904-95.31	ADJUSTMENT OF PREFORMED PULL BOX	EACH	26		
26	904-95.40	ADJUSTMENT OF CONCRETE SINGLE PULL BOX	EACH	1		
BICYCLE FACILITIES:						
27	JSP - T	PAVEMENT MARKING, BICYCLE SHARED LANE SYMBOL	EACH	13		
28	JSP - S	ROADWAY SIGN - BIKES MAY USE FULL LANE (MUTCD R4-11)	EACH	6		

CENTRAL BUSINESS DISTRICT RESURFACING PROJECT - PHASE 1						
PROJECT NO: STP-5438(613)						
BID FORM CONTINUED						
LINE NO.	ITEM NUMBER	ITEM DESCRIPTION	UNIT	QUANTITY	UNIT PRICE	TOTAL
PEDESTRIAN FACILITIES:						
29	JSP - U	CONCRETE SIDEWALK (5" THICK)	S.Y.	524.2		
30	JSP - U	CONCRETE SIDEWALK, CURB RAMP (7" THICK)	S.Y.	163.6		
31	JSP - U	DETECTABLE WARNING SURFACE	S.F.	256.8		
32	JSP - X	BRICK PAVER CARRIAGE STRIP	S.F.	408.4		
PAVEMENT MARKING AND STRIPING:						
33	JSP - T	4 IN. WHITE HIGH BUILD WATERBORNE PAVEMENT MARKING PAINT, TYPE L BEADS	L.F.	5578		
34	JSP - T	4 IN. YELLOW HIGH BUILD WATERBORNE PAVEMENT MARKING PAINT, TYPE L BEADS	L.F.	7631		
35	JSP - T	12 IN. WHITE HIGH BUILD WATERBORNE PAVEMENT MARKING PAINT, TYPE L BEADS	L.F.	1518		
36	JSP - T	24 IN. WHITE HIGH BUILD WATERBORNE PAVEMENT MARKING PAINT, TYPE L BEADS	L.F.	428		
37	JSP - T	PAVEMENT MARKING, LEFT TURN ARROW	EACH	34		
38	JSP - T	PAVEMENT MARKING, RIGHT TURN ARROW	EACH	16		
39	JSP - T	PAVEMENT MARKING, THROUGH ARROW	EACH	5		
40	JSP - T	PAVEMENT MARKING, COMBINATION STRAIGHT LEFT	EACH	2		
41	JSP - T	PAVEMENT MARKING, COMBINATION STRAIGHT RIGHT	EACH	4		
42	JSP - T	PAVEMENT MARKING WORD "STOP"	EACH	5		
43	JSP - T	ACCESSIBLE PARKING SPACE PAVEMENT MARKING	EACH	6		
44	JSP - S	RESERVED PARKING SIGN (MUTCD R7-8)	EACH	2		
TRAFFIC SIGNAL ITEMS:						
45	902-52.00	CONDUIT, 2 IN., TRENCH	L.F.	25		
46	904-49.22	DETECTOR, PEDESTRIAN PUSH BUTTON, APS, FREEZEPROOF	EACH	2		
47	904-85.05	CABLE, DETECTOR LOOP, #14 GAUGE, 1 CONDUCTOR, W/TUBE JACKET (IN CONDUIT AND PULL BOX)	L.F.	34		
48	904-85.06	CABLE, DETECTOR LOOP, #14 GAUGE, 1 CONDUCTOR, W/TUBE JACKET (IN SAWED SLOT)	L.F.	368		
49	904-85.34	CABLE, COMMUNICATION, #18 GAUGE, 4 CONDUCTOR (APS)	L.F.	230		
50	904-95.10	OPENING DRILLED IN EXISTING CONCRETE PULL BOX	EACH	2		
51	JSP - Y	NEW STANCTION POST (INCLUDES BASE)	EACH	2		
NON-PARTICIPATORY ITEMS:						
52	JSP - V	BRICK PAVER CROSSWALK	S.F.	5910		
53	JSP - W	PCC BASE FOR CONCRETE PAVERS	L.F.	750		
TOTAL	BASE BID WRITTEN:				BASE BID NUMBERS:	

CENTRAL BUSINESS DISTRICT RESURFACING PROJECT - PHASE 1						
PROJECT NO: STP-5438(613)						
BID FORM CONTINUED						
LINE NO.	ITEM NUMBER	ITEM DESCRIPTION	UNIT	QUANTITY	UNIT PRICE	TOTAL
		ADD ALTERNATE A:				
54	404-12.71	SUPERPAVE ASPHALTIC CONCRETE MIXTURE SP125 (PG 70-22) CLP	TON	27.9		
55	JSP - N	HIGH TENSILE STRENGTH SYNTHETIC FIBERS	LBS.	28		
56	407-10.27	TACK-EMULSIFIED ASPHALT (SS-1H)	GAL.	30		
57	412-10.04	PAVEMENT SURFACING AND TEXTURING (0" TO 4"), CONCRETE OR ASPHALT	S.Y.	260		
58	904-85.05	CABLE, DETECTOR LOOP, #14 GAUGE, 1 CONDUCTOR, W/TUBE JACKET (IN CONDUIT AND PULL BOX)	L.F.	159		
59	904-85.06	CABLE, DETECTOR LOOP, #14 GAUGE, 1 CONDUCTOR, W/TUBE JACKET (IN SAWED SLOT)	L.F.	712		
TOTAL	ADD ALTERNATE A WRITTEN:				ADD ALTERNATE A NUMBERS:	
TOTAL	BASE BID PLUS ADD ALTERNATE WRITTEN:				BASE BID PLUS ADD ALTERNATE A NUMBERS:	

BID BOND

KNOW ALL PERSONS BY THESE PRESENTS, that we _____
as principal and _____
as surety, are held and firmly bound unto the (Insert LPA Name) _____ in the penal sum
of _____ Dollars (\$) _____ to be paid to the commission to
be credited to the state road fund, the principal and surety binding themselves, their heirs, executors, administrators, successors,
and assigns, jointly and severally, firmly by these presents.

Sealed with our seals and dated this _____

THE CONDITION OF THIS OBLIGATION is such that

WHEREAS the principal is submitting herewith a bid to the commission on route(s)

in _____ County(ies),
project (s) _____

for construction or improvement of state highway as set out in said bid;

NOW THEREFORE, if the commission shall accept the bid of the principal and if the principal shall properly execute and deliver to the commission the contract, contract bond, and evidence of insurance coverage in compliance with the requirements of the bid, the specifications, and the provisions of section 227.100 RSMo, to the satisfaction of the commission, then this obligation shall be void and of no effect, otherwise to remain in full force and effect.

In the event the said principal shall, in the judgment of the commission, fail to comply with any requirement as set forth in the preceding paragraph, then the state of Missouri, acting by and through the commission, shall immediately and forthwith be entitled to recover the full penal sum above set out, together with court costs, attorney's fees, and any other expense of recovery.

The principal and surety hereby certify that the document is the original or a verbatim copy of the bid bond form furnished by the Commission, in accordance with Sec 102.9 of the Missouri Standard Specifications for Highway Construction.

NOTE: This bond must be executed by the principal, and by a corporate surety authorized to conduct surety business in the state of Missouri.

SEAL By _____
Principal
Signature

SEAL By _____
Surety
Signature of Attorney in Fact

Form ECR-101 (Rev. 05/2020)

DBE Identification Submittal Form

(For Local Program Agency (LPA) Projects)

Job Number: _____

Route: _____

County: _____

Prime Contractor: _____

Contract Amount: _____

Identification of Participating DBE's: Provide the requested information below for each DBE participating on the project. Submit this information with your bid or to _____ no later than 4:00 p.m. on the 3rd working day after the bid opening. Fax or e-mail transmittal is permitted. The fax number is _____ and the e-mail address for submittal is _____. Contact MoDOT's External Civil Rights Division (ECR) at (573) 526-2978 for questions and assistance on completion. **This page of this document must be received for each DBE utilized on the project.**

All information must be provided.

If awarded the contract for this project, the undersigned will use the following DBE to perform or furnish the work, supplies, and/or services as shown below:

DBE Name: _____ Address: _____

(A) Line No.	(B) Dollar Value of DBE Work** (Unit Price x Quantity of the Item in (A), or Lump Sum)	(C) Dollar value applicable to DBE Goal** (100%, 60%)	(D) Dollar amount applicable to DBE Goal (B x C)	(E) Percent of total contract amount for line item (D / total contract amount)	Add or Remove Lines	
					-	+
					-	+
					-	+
					-	+
					-	+
					-	+
					-	+
					-	+
					-	+
					-	+
DBE Total:				Total %		

**Cannot exceed contract amount for given item of work
 Trucking services credited at 100% if the DBE owns the trucks or is leasing from a DBE firm
 Allowed amount of participation will be in accordance with 49 CFR Part 26.
 Brokered services will only receive credit for fees.

Respectfully submitted:

Company Name (Prime Contractor)

Name / Title

Signed (Prime Contractor)

**Instructions for Completing the
DBE Identification Submittal Form
(For Local Program Agency (LPA) Projects)
(ECR-101)**

Submit this form with your bid or as outlined on front of page no later than 4:00 p.m. on the 3rd working day after the bid opening. Only DBE's listed on MoDOT's Missouri Regional Certification Committee (MRCC) directory may be used towards obtaining the DBE goal on the project. DBE firm must be certified with the appropriate North American Industrial Classification System (NAICS) code for the type of work being utilized to perform. The MRCC directory is available at the following link under the MRCC Directory tab: [HTTP://www.modot.org/welcome-external-civil-rights](http://www.modot.org/welcome-external-civil-rights)

- (A) Insert Bid Line Item in the same order as it appears in the bid document.
- (B) Insert the result from multiplying the unit price for the bid line item by the quantities listed in column (A); a lump sum, if applicable, may also be inserted.
- (C) Insert the percentage of column (B) that the DBE will perform. If the DBE is a supplier as that term is defined in 49 CFR Part 26.55, then only 60% of the value in column (B) can be applied towards the contract specific goal. If the DBE is furnishing and installing the line item, then 100% of the value can be applied.
- (D) Insert the result from dividing columns (B) and (C).
- (E) Insert the result from dividing column (D) from the total bid line item amount.

**DISADVANTAGED BUSINESS ENTERPRISE (DBE) PROGRAM REQUIREMENTS
FOR LOCAL PROGRAMS**

1.0 Program Applicability. The subsequent sections will apply only to contracts involving U.S. Department of Transportation (USDOT) federal-aid or federal funded participation. Federal-aid or federal funded participation includes, but is not limited to, any funds directly or indirectly received by MoDOT, or authorized for distribution to or through MoDOT, by the USDOT or any operating administration within the USDOT. These provisions will not apply to contracts funded exclusively with state funds, or state and local funds. Any contractor, subcontractor, supplier, DBE firm, and contract surety involved in the performance of a federal-aid contract shall be aware of and fully understand the terms and conditions of the USDOT DBE Program, as the terms appear in Title 49 CFR Part 26 (as amended), the USDOT DBE Program regulations; Title 7 CSR Division 10, Chapter 8 (as amended), and the Commission’s DBE Program rules.

2.0 DBE Program Distinguished From Other Affirmative Action Programs. The USDOT DBE Program established by the U.S. Congress is not the same as, and does not involve or utilize, any of the elements or authority of other state or local affirmative action programs, nor does the program rely upon state legislation or gubernatorial executive orders for implementation or authorization, other than the general authority given the Commission in Section 226.150, RSMo. The USDOT DBE Program is implemented by the Commission and MoDOT, through and in conjunction with the FHWA, FTA and FAA, as a “recipient” defined in Title 49 CFR 26.5.

3.0 Policy Regarding DBE Firms. It is the policy of the U. S. Department of Transportation and MoDOT that businesses owned by socially and economically disadvantaged individuals have an opportunity to participate in the performance of contracts funded in whole or in part with federal funds. Consequently, the requirements of 49 CFR Part 26 (as amended) and the Commission's implementing state regulations in Title 7 CSR Division 10, Chapter 8, "Disadvantaged Business Enterprise Program", will apply to any contract funded in whole or part with federal funds.

4.0 Opportunity for DBEs to Participate. Each contractor, subcontractor and supplier working on a contract funded in whole or in part with federal funds shall take all necessary and reasonable steps to ensure that DBEs have an opportunity to compete for and participate in performance on project contracts and subcontracts in which a DBE goal is established.

5.0 Required Contract Provision. The federal-aid contract will include the following provision, as mandated by USDOT at Title 49 CFR 26.13(b):

(a) The contractor, subrecipient or subcontractor shall not discriminate based on race, color, national origin, or gender in the performance of the contract. The contractor shall carry out applicable requirements of 49 CFR Part 26 in the award and administration of USDOT-assisted contracts. Failure by the contractor to carry out these requirements is a material breach of the contract, which may result in the termination of the contract or such other remedy, as the recipient deems appropriate.

In this provision, “contractor” will be defined as the contractor on the contract; sub-contractor, or material supplier performing the work on or for the project. For the purposes of any federal-aid contract awarded by the Local Public Agency (LPA), they will be designated as “the recipient”. The contractor shall include this same contract provision in every supply contract or subcontract the contractor makes or executes.

6.0 DBE Program Information. DBE Program information may be obtained from the MoDOT External Civil Rights Division, 105 W. Capitol Avenue, P.O. Box 270, Jefferson City, Missouri 65102-0270. Phone (573) 751-7801, Fax (573) 526-0558, E-Mail: dbe@modot.mo.gov. It will be the duty of each contractor, and for the contractor’s subcontractors to take the steps necessary to determine the legal obligations and limitations under the DBE Program, as an element of responsibility. It will be the duty of each certified DBE firm to know, understand and comply with the DBE firm’s legal obligations and limitations under the DBE Program, as a requirement of program participation.

7.0 DBE Certification, and the Missouri Unified Certification Program. MoDOT and other certifying agencies within Missouri have partnered to form the Missouri Regional Certification Committee (MRCC) and developed a Unified Certification Program (UCP) pursuant to 49 CFR 26.81 and 7 CSR 10-8.061. Only DBE firms certified by the MRCC are eligible to perform work on a federal-aid contract for DBE contract goal credit. It is the contractor’s responsibility to ensure firms identified for participation are approved certified DBE firms.

The MRCC DBE Directory can be found at the following link: <https://www.modot.org/welcome-external-civil-rights>

8.0 DBE Program-Related Certifications Made By Bidders and Contractors. If the bidder makes a written, express disclaimer of one or more certifications or assurances in the bid, the bid will be considered non-responsive. By submitting a bid on any project involving USDOT federal financial participation, and by entering into any contract on the basis of that bid, the contractor makes each of the following DBE Program-related certifications and assurances to USDOT, to the Commission, to MoDOT, and to the LPA:

(a) The bidder certifies that management and bidding officers have reviewed and understand the bidding and project construction and administration obligations of the USDOT DBE Program regulations at Title 49 CFR Part 26 (as amended), , and the Commission’s DBE Program rules at Title 7 CSR Division 10, Chapter 8 (as amended).

(b) The bidder agrees to ensure that certified DBE firms have a full and fair opportunity to participate in the performance of the contract financed in whole or in part with federal funds. The bidder certifies that all necessary and reasonable steps were taken to ensure that DBE firms have an opportunity to compete for, and perform work on the contract. The bidder further certifies that the bidder not discriminate on the basis of race, color, age, national origin or gender in the performance of the contract, or in the award of any subcontract.

(c) The bidder certifies that if awarded the federal-aid contract, the contractor will make a good faith effort to utilize certified DBE firms committed to with the awarded contract.

(d) The bidder certifies, that if awarded the federal-aid contract with less than the original DBE contract goal proposed by the Commission in the bid documents, as a result of an approved good faith effort, the revised lower amount shall become the final DBE goal, and that goal will be used to determine any liquidated damages to be assessed at the completion of the project.

(e) The bidder understands and agrees that if awarded the contract the contractor is legally responsible to ensure that the contractor and each DBE, comply fully with all regulatory and contractual requirements of the USDOT DBE Program, and that each DBE firm participating in the contract fully perform the designated tasks, with the DBE's own forces and equipment, under the DBE's own direct supervision and management. The bidder certifies, that if awarded the contract and if MoDOT or the Commission determine that the contractor, a DBE or any other firm retained by the contractor has failed to comply with the DBE Program requirements or federal or state DBE Program regulations, the Commission, through MoDOT, shall have the sole authority and discretion to determine the extent of the monetary value to which the DBE contract goals have not been met at the project completion, and to assess against and withhold monetary damages from the contractor up to the full amount of that breach. The bidder further understands and agrees that this clause authorizes the Commission, through MoDOT, to determine and fix the extent of the damages caused by a breach of any contractual or regulatory DBE Program requirement and that the damage assessment will be enforced in addition to, and not in lieu of, any other general liquidated damages clause in the contract. By submitting a bid for a federal-aid contract, the bidder irrevocably agrees to such an assessment of liquidated damages for DBE Program purposes, and authorizes the Commission and MoDOT to make such an assessment of liquidated damages against the contractor, and to collect that assessment from any sums due the contractor under the contract, or any other contract, or by other legal process. The bidder makes this certification, agreement and authorization on behalf of itself, for each federal-aid contract.

9.0 Designation of DBE firms to perform on contract. The bidder states and certifies that the DBE participation information submitted in the bid or within the contract designated time is true, correct and complete and that the information provided includes the names of all DBE firms that will participate in the contract, the specific line item (s) that each DBE firm will perform or partially perform, and the creditable dollar amounts of the participation of each DBE. The specific line item must reference the bid line number and item number contained in the proposal. The bidder further states and certifies that the bidder has committed to use each DBE firm listed for the work shown to meet the DBE contract goal and that each DBE firm listed has clearly confirmed to the bidder that the DBE firm will participate in and perform the work, with the DBE's own forces.

(a) The bidder certifies the bidder’s understanding that as the contractor on a contract funded in whole or in part by USDOT federal funds, the bidder may not unilaterally terminate, substitute for, or replace any DBE firm that was designated in the executed contract, in whole or in any part, with another DBE, any non-DBE firm or with the contractor's own forces or those of an affiliate, without the prior written consent of MoDOT. The bidder understands it must receive approval in writing from MoDOT for the termination of a DBE firm, or the substitution or replacement of a DBE before any substitute or replacement firm may begin work on the project in lieu of the DBE firm participation information listed in the executed contract. Unless MoDOT’s written consent is provided as outlined above, the bidder shall not be entitled to any payment of work or material unless it is performed or supplied by the listed DBE.

(1) The bidder further certifies understanding, that if a DBE firm listed in the bid or approved in the executed contract documents ceases to be a certified DBE firm, at any time during the performance of the contract work, and a contract or subcontract with that firm has not yet been executed by the prime and subcontractor, the contractor can not count any work performed by that firm after the date of the firm’s loss of eligibility toward meeting the DBE contract goal. The contractor can pursue efforts to replace the work planned with the decertified firm, with other certified DBEs, in coordination with MoDOT’s External Civil Rights Division. However, if the contractor has executed a subcontract with the firm before the DBE lost eligibility and ceased to be a certified DBE, the contractor may continue to receive credit toward the DBE contract goal for that firm's work.

(2) The bidder further certifies the bidder’s understanding, that the dollar value of any work completed by a DBE firm prior to approval of the DBE’s substitution or replacement, in writing, by MoDOT will not be credited toward meeting the DBE contract goal. No credit toward the DBE goal will be given for any amount withheld from payment to the DBE or “back charged” against monies owed to the DBE, regardless of the purpose or asserted debt.

10.0 Contract Goal, Good Faith Efforts Specified. The bidder may submit the completed “DBE Identification Submittal” information in the bid documents at the same time as, and within the sealed bid, at the time the bid is submitted. However, if that information is not completed and submitted with the initial sealed bid, then as a matter of responsiveness and responsibility, all bidders shall file the completed “DBE Identification Submittal” pages to the Local Agency on or before 4:00 p.m. of the third business day after the bid opening date. The Local Agency may permit telefax transmittal. No extension of time will be allowed for any reason. The means of transmittal and the risk of timely receipt of the information shall be the bidder’s.

10.1 Good Faith Effort Submittal. If the bidder is not able to meet the Commission’s DBE contract goal, the bidder has the opportunity to submit with and as a part of the bid, a true, accurate, complete and detailed written explanation of good faith efforts taken to meet the DBE Contract Goal established in the bid documents. The bidder shall use the

“DBE Identification Submittal” sheets for any DBE participation that will be committed towards the goal and an explanation, with any supporting documentation, for the inability to meet the full goal established on the contract. Any Good Faith efforts shall be submitted as part of the bid or within the three business days after the bid opening.

10.2 Bidders Good Faith Effort Described. MoDOT will consider the quality, quantity, and intensity of the different kinds of efforts that the bidder has made based upon 49 CFR Appendix A to Part 26 and the following additional efforts:

- (a) Providing documentation on any and all past GFE activities for review.
- (b) Past project DBE performance utilization.
- (c) Race neutral methods utilized on completed projects.

All good faith efforts are evaluated on a case-by-case basis whereas any of the numerous good faith elements listed individually or collectively is not a guarantee of approval.

10.3 Administrative Reconsideration of the Bidder’s Good Faith Efforts Made as a Part of the Bid Submittal. If MoDOT determines that the apparent low bidder has failed to adequately document in the bid that the bidder made a good faith effort to achieve sufficient DBE participation in the contract work, that firm will be offered the opportunity for administrative reconsideration upon written request, before MoDOT and the Commission reject that bid as non-responsive.

10.4 Forfeiture of Bid Bond possible when: The failure of either the apparent low bidder to file the completed and executed “DBE Identification Submittal”, listing actual, committed DBE participation equal to or greater than the DBE contract goal percentage specified in the bid by 4:00 p.m. on the third business day after the bid opening, will be cause for rejection of that bid. In addition, the bid surety bond or bid guaranty of the apparent low bidder will be forfeited to and become the property of the Local Agency upon demand, only if the contract is awarded

(a) Any bidder rejected for failure to submit the completed and executed “DBE Identification Submittal” information in the bidding documents, with full documentation of sufficient DBE participation to satisfy the DBE contract goal cannot submit a bid on the same, or substantially similar, project, when and if the project is re-advertised for bids. By submitting a bid on a federal-aid project, the bidder accepts and agrees to these provisions, and the disposition of the bidders bid bond or guaranty, upon demand by the Local Agency.

(b) The surety separately acknowledges the surety to be held and firmly bound to the Local Agency to immediately upon demand pay the face amount of the bid bond.

11.0 DBE Participation for Contract Goal Credit. In addition to participation outlined by 49 CFR part 26, the following shall apply:

In addition to allowances provided for in the Federal Regulations, a bidder may count toward the DBE contract goal the following expenditures to certified DBE firms that are not “regular dealers” or “manufacturers” for DBE program purposes:

- (1) A bidder may count toward the DBE contract goal 100 percent of the fees paid to a certified DBE trucker or hauler for delivery of material and supplies required on a job site, but not for the cost of those materials or supplies themselves, or for the removal or relocation of excess material from or at the job site, when the DBE certified trucking company is not also the manufacturer of or a regular dealer in those material and supplies, provided that the trucking or hauling fee is determined by MoDOT to be reasonable as compared with fees customarily charged by non-DBE firms for similar services. The certified DBE trucking firm shall also perform a CUF on the project and not operate merely as a pass through for the purposes of gaining credit toward the contract DBE goal. Prior to submitting a bid, the bidder shall determine, whether a DBE trucking firm will meet the criteria for performing a CUF on the project.
- (2) The bidder will receive DBE contract goal credit for the fees or commissions charged by and paid to a DBE broker who arranges or expedites sales, leases or other project work or service arrangements, provided that those fees are determined by MoDOT to be reasonable and not excessive, as compared with fees customarily charged by non-DBE firms for similar services. A broker will be defined as a person or firm that does not own or operate the delivery equipment necessary to transport materials, supplies or equipment to or from a job site. In most instances, the broker is merely the entity making arrangements for delivery of material, supplies, equipment, or arranging project services. To receive DBE contract goal credit, MoDOT must determine that the DBE broker has performed a CUF in providing the contract work or service.

12.0 DBE Required to Perform a Commercially Useful Function (CUF). The DBE CUF requirements are stated in 49 CFR Part 26, (26.55). Any questions or further information needed for CUF determinations should be directed to MoDOT’s External Civil Rights Division.

12.1 Quality Control (QC) and Quality Assurance (QA) Reviews. The prime contractor shall monitor their planned DBE project usage for CUF compliance and provide MoDOT information for areas of concern for further evaluation. MoDOT will perform a QA review, or compliance review, for DBE CUF and project documentation retained by the contractor through project completion. The contractor shall maintain all DBE related information it has received, documented and provided to MoDOT for a period of three years beyond the date of final inspection. MoDOT’s determination that a DBE’s participation may not count toward the project goal, or good faith effort level approved will be subject to administrative reconsideration.

12.2 MoDOT Makes Final Determination On Whether a CUF Is Performed. MoDOT will have the final authority to determine whether a DBE firm has performed a CUF on a federal-aid contract.

13.0 Verification of DBE Participation at project completion. (Assessment of Liquidated Damages Possible)

13.1 Prior to final payment by the Local Agency, the contractor shall file with the Local Agency a detailed list showing each DBE used on the contract work, and the work performed by each DBE. The list shall show the actual dollar amount paid to each DBE for the creditable work on the contract, less any rebates, kickbacks, deductions, withholdings or other repayments made. The list shall be certified under penalty of perjury, or other law, to be accurate and complete. MoDOT and the Commission will use this certification and other information available to determine if the contractor and the contractor's DBEs satisfied the DBE contract goal percentage specified in the contract and the extent to which the DBEs were fully paid for that work. The contractor shall acknowledge, by the act of filing the detailed list, that the information is supplied to obtain payment regarding a federal participation contract.

13.2 Failure on the part of the contractor to achieve the DBE participation to which the contractor committed in the contract may result in liquidated damages being imposed on the contractor by the Commission for breach of contract and for non-compliance. If the contract was awarded with less than the original DBE contract goal proposed by the Commission, the revised lower amount became the final DBE contract goal, and that goal will be used to determine any liquidated damages to be assessed. Additionally, the Commission or MoDOT may impose any other administrative sanctions or remedies available at law or provided by the contract in the event of breach by the contractor by failing to satisfy the contractor's DBE contract goal commitment. The contractor will be offered the opportunity for administrative reconsideration of any assessment of liquidated damages determined at the project completion, upon written request. The administrative reconsideration officer may consider all facts presented, including the legitimacy or business reason for back charges assessed against a DBE firm, in determining the final amount of liquidated damages.

14.0 Miscellaneous DBE Program Requirements. In accordance with Title 49 CFR Part 26 and the Commission's DBE Program rules in Title 7 CSR Division 10, Chapter 8, the contractor, for both the contractor and for the contractor's subcontractors and suppliers, whether DBE firms or not, shall commit to comply fully with the auditing, record keeping, confidentiality, cooperation and anti-intimidation or retaliation provisions contained in those federal and state DBE Program regulations. By bidding on a federal-aid contract, and by accepting and executing that contract, the contractor agrees to assume these contractual obligations, and to bind the contractor's subrecipients contractually, at the contractor's expense.

15.0 Data Collection from Bidders for DBE and Non-DBE Subcontractors, Suppliers, Manufacturers and/or Borkering used and not used in bids during the reporting period. MoDOT is a recipient of federal funds and is required by 49 CFR

26.11, to provide data about its DBE program. The information shall consist of all subcontractor quoting received for actual use and of consideration by the prime bidder. MoDOT will be requesting this information from bidding prime contractors and will provide prime bidders a form to submit the data by the last day of each month for the current letting. The information shall only include the names of both DBE and non-DBE companies that the prime bidders received quotes. MoDOT will then contact the DBEs and non-DBE subcontractors and request additional information from DBE and non-DBE subcontractors including current year of gross receipts and number of years in business. The information provided by the prime bidders shall not include any bid quote pricing regardless if it was used or not. This information will aid MoDOT in the determination of the availability of DBEs and will be used in subsequent availability studies.

GENERAL CONDITIONS

(General Conditions shall prevail over Specifications whenever in conflict therewith)

ARTICLE 1 - CONTRACT DOCUMENTS

1.1 DEFINITIONS

1.1.1 The Contract Documents. The Contract Documents consists of the Invitation for Bids and Bid Specifications previously issued by the City for the Work and Contractor's submission in response thereto, the City-Contractor Agreement, General Conditions of the City-Contractor Agreement, Non-Collusion Affidavit, the Performance and Payment Bond, the Drawings, the Technical Specifications, the Construction Schedule, all Addenda and all Modifications issued after execution of the Contract. a Modification is (1) a written amendment to the Contract signed by both parties, or (2) a Change Order.

1.1.2 The Contract. The Contract documents form the Contract. The Contract represents the entire and integrated agreement between the parties hereto and supersedes all prior negotiations, representations or agreements, both written and oral, including the bidding documents. The Contract may be amended or modified only by a Modification as defined in Subparagraph 1.1.1.

1.1.3 The Work. The term Work includes all labor necessary to complete the construction required by the Contract Documents, and all materials and equipment incorporated or to be incorporated in such construction.

1.1.4 The Project. The Project is the total construction of which the Work performed under the Contract Documents may be the whole or a part.

1.1.5 Notice to Proceed. The written notice from the City notifying the Contractor of the date on or before which Contractor is to begin prosecution of the work.

1.1.6 Standard Specifications:

The St. Louis County Standard Specifications for Highway Construction (March 15, 2022 edition).

The Standards Specifications for Construction of all sewer work shall be applicable sections of the Standard Construction Specification for Sewer and Drainage Facilities 2009 Metropolitan St. Louis Sewer District..

1.1.7 Substantial Completion: The state in the progress of the Work when the Work or a designated portion thereof is sufficiently complete in accordance with the Contract Documents so the City can reasonably occupy or utilize the Work for its intended use.

1.2 EXECUTION, CORRELATION, INTENT AND INTERPRETATIONS

1.2.1 The Contract Documents shall be signed in not less than triplicate by the City and Contractor.

1.2.2 The Contractor represents that Contractor has visited the site, become familiar with the local conditions under which the Work is to be performed, and correlated any observations with the requirements of the Contract Documents.

1.2.3 The Contract Documents are complementary, and what is required by any one shall be as binding as if required by all. The intention of the Contract Documents is to include all labor, materials, equipment and other items as provided in Subparagraph 3.3 necessary for execution and completion of the Work. Words which have well-known technical or trade meanings are used herein in accordance with such recognized meanings.

1.3 COPIES FURNISHED AND OWNERSHIP

1.3.1 Unless otherwise provided in the Contract Documents, the Contractor will be furnished a maximum of six (6) copies, free of charge, of the Drawings and Specifications for the execution of the work.

1.3.2 All Drawings, Specifications and copies thereof furnished by the City are and shall at all times remain property of the City. Such documents shall not be used on any other project.

ARTICLE 2 - CITY

2.1 DEFINITION

2.1.1 The term City means the City or its authorized representative.

2.2 CITY'S RIGHT TO STOP THE WORK

2.2.1 If the Contractor fails to correct defective Work or fails to supply materials or equipment in accordance with the Contract Documents, the City may order the Contractor to stop the Work, or any portion thereof, until the cause for such order has been eliminated.

2.3 CITY'S RIGHT TO CARRY OUT THE WORK

2.3.1 If the Contractor defaults or neglects to carry out the Work in accordance with the Contract Documents, or fails to perform any provision of the Contract, the City may, after seven (7) days' written notice to the Contractor and without prejudice to any other remedy City may have, make good such deficiencies. In such case an appropriate Change Order shall be issued deducting from the payments then or thereafter due the Contractor the cost of correcting such deficiencies. If the payments then or thereafter due the Contractor are not sufficient to cover such amount, the Contractor shall pay the difference to the City promptly upon request.

ARTICLE 3 - CONTRACTOR

3.1 DEFINITION

3.1.1 The Contractor is the person or organization identified as such in the City-Contractor Agreement and is referred to throughout the Contract Documents as if singular in number and masculine in gender. The term Contractor means the Contractor or Contractor's authorized representative. The Contractor shall not subcontract except in accordance with the terms of this Agreement.

3.2 SUPERVISION AND CONSTRUCTION PROCEDURES

3.2.1 The Contractor shall supervise and direct the Work, using his best skill and attention. Contractor shall be solely responsible for all construction means, methods, techniques, sequences and procedures and for coordinating all portions of the Work.

3.3 LABOR, MATERIALS AND EQUIPMENT

3.3.1 Unless otherwise specifically noted, the Contractor shall provide and pay for all labor, materials, equipment, tools, construction equipment and machinery, water, heat, utilities, transportation, and other facilities and services necessary for the proper execution and completion of the Work.

3.3.2 The Contractor shall at all times enforce strict discipline and good order among his employees and shall not employ on the Work any unfit person or anyone not skilled in the task assigned to him. If the City reasonably objects to any person employed by the Contractor, the employee shall be immediately dismissed from the Work.

3.3.3 The Contractor shall execute and complete the Work in such a manner that avoids jurisdictional and other disputes among labor unions.

3.3.4 The Contractor shall comply with, and is bound by, the provisions of Missouri statutes pertaining to the payment of wages on public works projects contained in sections 290.210 through 290.340 (RSMo 2000), and any amendments thereto, including, but not limited to the following:

- 1) In accordance with section 290.250, the Contractor shall not pay less than the prevailing hourly rate of wages specified by the Missouri Department of Labor and Industrial Relations Division of Labor Standards to all workers performing Work under the Agreement.
- 2) In accordance with section 290.250, the Contractor shall forfeit as a penalty to the City ten dollars (\$10.00) for each worker employed for each calendar day, or portion thereof, such worker is paid less than the said stipulated rates for any Work done under the Agreement, by him or by any Subcontractor under him and shall include provisions in all bonds guaranteeing the faithful performance of said prevailing hourly wage clause.
- 3) In accordance with section 290.265, the Contractor shall post a clearly legible statement of all prevailing hourly wage rates to be paid to all workers employed to complete the Work in a prominent and easily accessible place at the site of the Work and such notice shall remain posted during the full time that any workers shall be employed on the Work.
- 4) Certified payrolls shall also be submitted prior to final payment for all Work completed by the Contractor or Subcontractors.
- 5) In accordance with section 290.290, before final payment is made an affidavit must be filed by the Contractor stating that he has fully complied with the prevailing wage law. No payment shall be made unless and until this affidavit is filed therewith in proper form and order.

3.4 WARRANTY

3.4.1 Section removed

3.5 PERMITS, FEES AND NOTICES

3.5.1 The Contractor shall secure and pay for all permits, governmental fees and licenses necessary for the proper execution and completion of the Work.

3.5.2 The Contractor shall give all notices and comply with all laws, ordinances, rules, regulations and orders of any public authority bearing on the performance of the Work. If the Contractor observes that any of the Contract Documents are at variance therewith in any respect, he shall promptly notify the City in writing and any necessary changes shall be adjusted by appropriate Modification. If the Contractor performs any Work knowing it to be contrary to such laws, ordinances, rules and regulations and without such notice to the City, the Contractor shall assume full responsibility thereof and shall bear all costs attributable thereto.

3.6 SUPERINTENDENT

3.6.1 This person shall be a non-working superintendent who will be responsible for the satisfactory progression of the work and to ensure that all work is being completed in accordance with the plans and specifications. This person is also to relay any conflicts or discrepancies that arise in the plans to the City's representative for resolution or interpretation. The superintendent shall represent the Contractor and all communications given to the superintendent shall be as binding as if given to the Contractor.

3.7 RESPONSIBILITY FOR THOSE PERFORMING THE WORK

3.7.1 The Contractor shall be responsible to the City for the acts and omissions of all his employees and all Subcontractors, their agents and employees and all other persons performing any of the Work under a Contract with the Contractor.

3.8 DRAWINGS AND SPECIFICATIONS AT THE SITE

3.8.1 The Contractor shall maintain at the site for the City one copy of all Drawings, Specifications, Addenda, approved Shop Drawings, Change Orders and other Modifications, in good order and marked to record all changes made during construction. The Drawings, marked to record all changes made during construction, shall be delivered to the City upon completion of the Work. The Contractor shall also maintain on the project site a survey level, legs, and rod at all times, which are deemed adequate by the project engineer.

3.9 CLEANING UP AND STORAGE

3.9.1 The Contractor at all times shall keep the premises free from accumulation of waste materials or rubbish caused by his operations. The Contractor shall not "stockpile" any material on the jobsite and all excavated material shall be hauled off the site at the time of excavation. However, stockpiling of materials delivered and used on the same day will be allowed if all materials are in place or removed at the end of the day.

3.9.2 In conjunction with Sec. 106.5 of the Standard Specifications, the Contractor is responsible for securing his own project storage site which shall not be located on City Right-of-Way without prior written consent of the Director of Public Works. After completion of the Work the Contractor shall remove all remaining waste materials and rubbish from and about the Project as well

as all tools, construction equipment, machinery and surplus materials, and shall clean all surfaces and leave the Work "broom clean" or its equivalent, except as otherwise specified.

3.9.3 The Contractor shall make satisfactory arrangements to store material and equipment after delivery and during construction off of the City right-of-way. The City will assume no responsibility for these arrangements.

3.10 CASH ALLOWANCES

3.10.1 The Contractor acknowledges and agrees that the Contract Sum includes all cash allowances specified in the Contract Documents.

ARTICLE 4 - SUBCONTRACTORS

4.1 DEFINITION

4.1.1 A Subcontractor is a person or organization who has a direct contract with the Contractor to perform any of the Work.

4.1.2 Nothing contained in the Contract Documents shall create any contractual relation between the City and any Subcontractor or Sub-subcontractor.

4.2 AWARD OF SUBCONTRACTS AND OTHER CONTRACTS FOR PORTIONS OF THE WORK

4.2.1 Unless otherwise specified in the Contract Documents or in the Bidders Checklist, the Contractor shall submit a completed and signed Subcontractor Approval form, along with other required Bid documents to the City. Contractor shall complete and submit a Supplemental Subcontractor Approval form to the City in the event of any substitution or addition of a Subcontractor by the Contractor. No work shall be performed by a Subcontractor until such Subcontractor has been approved by the City.

4.2.2 Prior to the award of the Contract, the City will notify the Bidder in writing if the City, after due investigation, objects to any such person or entity proposed by the Bidder pursuant to Subparagraph 4.2.1 above. If the City objects to any such proposed person or entity, the Bidder may, at his option, (1) withdraw his Bid, or (2) submit an acceptable substitute person or entity with no adjustment in his bid price.

4.2.3 Contractor shall at all times during the term of the Contract be in compliance with Sec. 108.1 of the Standard Specifications and shall not subcontract more than forty nine percent (49%) of the total Contract cost.

4.2.4 The City reserves the right to reject a Subcontractor, if in the City's sole discretion, delays may result in the performance of Work as a result of Subcontractor's other obligation. The Contractor shall be held responsible, in addition to the submission of the "Subcontractor Approval Form," to apprise the City of any additional work which a Subcontractor accrues throughout the duration of the project. This shall include work for the City under a different Contract, or any other person or entity. If such said additional work shall detrimentally impact the progression of the Work under this Contract, the City retains the right to require the Contractor to submit a substitute Subcontractor for this work at no additional cost to the City.

4.2.5 The Contractor shall not contract with any Subcontractor or any person or organization (including those who are to furnish materials or equipment fabricated to a special design), for proposed proportions of the Work designated in the Contract Documents or in the Instruction to Bidders or, if none is so designated, with any Subcontractor proposed for the principal portions of the Work, who has been rejected by the City.

4.2.6 If the City requires a change of any proposed Subcontractor or person or organization during the execution of the Work approved under the present Contract, the Contract Sum shall be increased or decreased by the difference in cost resulting from such change and an appropriate Change Order shall be issued.

4.2.7 The Contractor shall not make any substitution for any proposed Subcontractor or person or organization that has not been accepted by the City prior to the Contract Award, unless the substitution is accepted by the City in writing prior to such substitution.

4.3 SUBCONTRACTUAL RELATIONS

4.3.1 All work performed for the Contractor by a Subcontractor shall be pursuant to an appropriate agreement between the Contractor and Subcontractor (and where appropriate between Subcontractors and Sub-subcontractors) which shall contain provisions that:

- 1) require the Work to be performed in accordance with the requirements of the Contract Documents;
- 2) require submission to the Contractor of applications for payment under each Subcontract to which the Contractor is a party, in reasonable time to enable the Contractor to apply for payment in accordance with Article 8 hereof;
- 3) require that all claims for additional costs, extensions of time, damages for delays or otherwise with respect to Subcontracted portions of the Work shall be submitted to the Contractor (via any Subcontractor or Sub-subcontractor where appropriate) in sufficient time so that the Contractor may comply in the manner provided in the Contract Documents for like claims by the Contractor upon the City;
- 4) waive all rights the contracting parties may have against one another for damages caused by fire or other perils covered by the property insurance described in Article 10 except such rights as they may have to the proceeds of such insurance held by the City as trustee;
- 5) obligate each Subcontractor specifically to consent to the provisions of this Paragraph 4.3; and
- 6) require the Subcontractor (and the Sub-subcontractor's to indemnify and hold harmless the City against all claims, damages, losses, expenses and attorneys' fees arising out of or resulting from the performance of the Work by Subcontractor, and its agents and employees, unless such claims, damages or losses are caused solely by the negligent act of the City.

4.4 PAYMENTS TO SUBCONTRACTORS

4.4.1 The Contractor shall pay each Subcontractor upon receipt of payment from the City, an amount equal to the percentage of completion allowed to the Contractor on account of such Subcontractor's Work, less the percentage retained from payments to the Contractor. The Contractor shall also require each Subcontractor to make similar payments to his Subcontractors.

4.4.2 If the City withholds payment to the Contractor for any cause that is the fault of the Contractor and not the fault of a particular Subcontractor, the Contractor shall pay that Subcontractor on demand for its Work to the extent completed.

4.4.3 The City shall not have any obligation to pay or to see to the payment of any sum to any Subcontractor or Sub-subcontractor.

ARTICLE 5 - SEPARATE CONTRACTS

5.1 CITY'S RIGHT TO AWARD SEPARATE CONTRACTS

5.1.1 The City reserves the right to award other contracts on other terms and conditions in connection with other portions of the Project.

5.1.2 During construction, it may become necessary to increase the amount of excavation or to utilize a soil stabilization process if unsuitable subgrade conditions are found. The Contractor shall immediately contact the project engineer if this condition occurs. The project engineer and the Contractor shall agree upon the existence of unsuitable subgrade, the depth in which to remove the unsuitable soil, and the extent of the problem area prior to any additional work. No payment will be made for any area that undergoes additional excavation that is not indicated in the above scope of work and has not been approved by the project engineer prior to the excavation. All additional excavation that becomes necessary shall be paid at the unit bid price for "Excavation." The City reserves the right to contract with a separate contractor for the use of a soil stabilization process. No direct payment will be made for delays incurred due to this process and the Contractor's only compensation will be the allotment of additional days for the delay. The number of days shall be from the time the Contractor initially notifies the City of an unsuitable subgrade condition and until two days after the completion of the soil stabilization process.

5.2 MUTUAL RESPONSIBILITY OF CONTRACTORS

5.2.1 The Contractor shall afford other contractors reasonable opportunity for the delivery and storage of their materials and equipment and the execution of their work, and shall properly connect and coordinate the Work with theirs.

5.2.2 If any part of the Work depends for proper execution or results upon the work of any other separate contractor, the Contractor shall inspect and promptly report to the City any apparent discrepancies or defects in such work that render it unsuitable for proper execution of the Work. Failure of the Contractor so to inspect and report shall constitute an acceptance of the other contractor's work as fit and proper to receive the Work, except as to defects which may develop in the other contractor's work after the execution of the Contractor's Work that could not have been discovered by the Contractor upon reasonable inspection.

5.2.3 If the Contractor causes damage to the work or property of any other contractor on the Project, and such separate contractor sues the City or initiates an arbitration proceeding on account of any damage alleged to have been so sustained, the City shall notify the Contractor who shall defend such proceedings at Contractor's own expense, and if any judgment or award against the City arises therefrom the Contractor shall pay or satisfy it and shall reimburse the City for all attorneys' fees and court or arbitration costs which the City has incurred.

5.3 CITY'S RIGHT TO CLEAN UP

5.3.1 If a dispute arises between the separate contractors as to their responsibility for cleaning up as required by Paragraph 3.9, the City may clean up and charge the cost thereof to the several contractors.

ARTICLE 6 - GENERAL PROVISIONS

6.1 GOVERNING LAW

6.1.1 The Contract shall be governed by the laws of the State of Missouri.

6.2 SUCCESSORS AND ASSIGNS

6.2.1 This Contract shall be binding upon the successors, assigns and legal representatives of each party in respect to all covenants, agreements and obligations contained in the Contract Documents. Neither party to the Contract shall assign the Contract without the prior written consent of the other, nor shall the Contractor assign any sums due or to become due to him hereunder, without the prior written consent of the City.

6.3 RIGHTS AND REMEDIES

6.3.1 The duties and obligations imposed by the Contract Documents and the rights and remedies available thereunder shall be in addition to and not a limitation of any duties, obligations, rights and remedies otherwise imposed or available by law.

6.4 ROYALTIES AND PATENTS

6.4.1 The Contractor shall pay all royalties and license fees payable on all designs, processes or products used in connection with the Work or incorporated therein, unless otherwise agreed upon by the City. The Contractor shall defend all suits or claims for infringement of any patent rights and shall indemnify and hold the City harmless from and against any loss on account thereof.

6.5 PERFORMANCE AND PAYMENT BOND

6.5.1 The Contractor shall furnish the performance and payment bond required in the City-Contractor Agreement.

ARTICLE 7 - TIME

7.1 DEFINITIONS

7.1.1 The Contract Time is the period of time allotted in the City-Contractor Agreement for completion of the Work. Said work shall include all punchlist items deemed necessary by the City, exclusive of MSD-generated punchlist items. The date of completion of the Contract shall be the date when all work including City punchlist items have been approved in writing by the City.

7.1.2 The date of commencement of the Work is the date established in the written Notice to Proceed from the City to the Contractor.

7.1.3. The term "day" as used in the Contract Documents shall mean calendar day.

7.2 PROGRESS AND COMPLETION

7.2.1 All time limits stated in the Contract Documents are of the essence.

7.2.2 The Contractor shall begin the Work on the date of commencement provided in the City-Contractor Agreement. The Contractor shall carry the Work forward expeditiously with adequate forces and shall complete it within the Contract Time and in accordance with the Construction Schedule.

ARTICLE 8 - PAYMENTS AND COMPLETION

8.1 CONTRACT SUM

8.1.1 The Contract Sum is stated in the City-Contractor Agreement and is the total amount payable by the City to the Contractor for the performance of the Work.

8.2 APPLICATION FOR PAYMENT

8.2.1 By 12:00 P.M. on or before the twentieth day of the month, upon Substantial Completion of various stages of the Work, and upon final completion of the Work, the Contractor shall submit to the City an itemized Application for Payment pursuant to the City-Contractor Agreement on such forms and supported by such data substantiating the Contractor's right to payment as the City may require.

8.2.2 If payments are to be made on account of materials or equipment to be incorporated into the Work and delivered and suitably stored at the site, such payments shall be conditioned upon submission by the Contractor of bills of sale or such other documents satisfactory to the City to establish the City's title to such materials or equipment or to otherwise protect the City's interest.

8.2.3 The Contractor warrants and guarantees that title to all Work, materials and equipment covered by an Application for Payment, whether incorporated into the Work or not, will pass to the City upon the receipt of such payment by the Contractor, free and clear of all liens, claims, security interests or encumbrances (hereinafter referred to as "liens").

8.3. PAYMENT

8.3.1 If the Contractor has made Application for Payment as above, the City will, in accordance with the City-Contractor Agreement, make payment to the Contractor for such amount as it determines to be properly due pursuant to the Contractor's Application for Payment, or state in writing the City's reasons for withholding all or any portion of such payment.

8.3.2 No progress payment, nor any partial or entire use or occupancy of the Work by the City, shall constitute an acceptance of any Work not completed in accordance with the Contract Documents.

8.4 COMPLETION AND FINAL PAYMENT

8.4.1 Upon receipt of written notice from the Contractor that the Work is fully completed and ready for final inspection and acceptance, and upon receipt of a final application for Payment, the City will promptly make such inspection and, when the City finds the Work acceptable under the Contract Documents and the Contract fully performed, the City will make final payment to the Contractor in accordance with the City-Contractor Agreement.

8.4.2 The final payment shall not become due until the Contractor submits to the City (1) an Affidavit that all payrolls, bills for materials and equipment, and other indebtedness incurred in connection with the execution and completion of the Work for which the City or its property might in any way be responsible, have been paid or otherwise satisfied, (2) consent of the surety, if any, to final payment, (3) if required by the City, other data establishing payment or satisfaction of all such obligations, such as receipts, releases and waivers of liens arising out of the Contract, to the extent and in such form as may be designated by the City and (4) Prevailing Wage Affidavit as required by subsection 3.3.4. If any Subcontractor refuses to furnish a release or waiver required by the City, the Contractor may furnish a bond satisfactory to the City indemnifying the City against any such lien. If any such lien remains unsatisfied after all payments are made, the Contractor shall refund to the City all moneys that the City may be compelled to pay in discharging such lien, including all costs and reasonable attorneys' fees.

8.4.3 The acceptance of final payment shall constitute a satisfaction of all claims by the Contractor, except those previously made in writing and still unsettled.

ARTICLE 9 - PROTECTION OF PERSONS AND PROPERTY

9.1 SAFETY PRECAUTIONS AND PROGRAMS

9.1.1 The Contractor shall initiate, maintain and supervise safety precautions and programs in connection with the performance of the Work.

9.2 SAFETY OF PERSONS AND PROPERTY

9.2.1 The Contractor shall take all reasonable precautions for the safety of, and shall provide all reasonable protection to prevent damage, injury or loss to:

- 1) all employees on the Work and all other persons who may be affected thereby;

2) all the Work, all materials and equipment to be incorporated therein, whether in storage on or off the site, under the care, custody or control of the Contractor or any of his Subcontractors or Sub-subcontractors; and

3) other property at the site or adjacent thereto, including trees, shrubs, lawns, walks, pavements, roadways, structures and utilities not designated for removal, relocation or replacement in the course of construction.

9.2.2 The Contractor shall comply with all applicable laws, ordinances, rules, regulations and lawful orders of any public authority having jurisdiction over the safety of persons or property to protect them from damage, injury or loss. The Contractor shall erect and maintain all reasonable safeguards for safety and protection, including posting danger signs and other warnings against hazards, promulgating safety regulations and notifying City and users of adjacent utilities. The Contractor shall provide signs, barrels, or any other safety devices that the City deems necessary for public safety. No additional payment will be made and this work shall be considered incidental to the Contract. The City will place safety devices as it deems necessary if the Contractor fails to provide the required items within 24 hours of notification. The Contract Sum shall be reduced by the cost of these devices.

9.2.3 When the use or storage of explosives or other hazardous materials or equipment is necessary for the execution of the Work, the Contractor shall exercise the utmost care and shall carry on such activities under the supervision of properly qualified personnel.

9.2.4 All damage or loss to any property caused in whole or in part by the Contractor, any Subcontractor, or any Sub-subcontractor, or anyone directly or indirectly employed by anyone for whose acts they may be liable, shall be remedied by the Contractor. The City shall document any complaint by any person regarding damage or loss to property caused by Contractor by requesting such complainant to complete a Damage Claim form. A copy of the Damage Claim form shall be submitted by the City to the Contractor and the Contractor shall correct the problem, repair such damage or otherwise compensate the complainant or file a claim for such damage with Contractor's insurance company within ten (10) days of the receipt of the Damage Claim form from the city. If the City shall have a legitimate basis for believing that such claim is valid, the City shall have the option to withhold payment of funds until (i) such damages are repaired; or (ii) the City has been provided with evidence that the Contractor has made restitution to the complainant.

9.2.5 The Contractor shall designate a responsible member of his organization at the site whose duty shall be the prevention of accidents. This person shall be the Contractor's superintendent unless otherwise designated in writing by the Contractor to the City.

ARTICLE 10 - PROPERTY INSURANCE

10.1 PROPERTY INSURANCE

10.1.1 Unless otherwise provided, the Contractor shall purchase and maintain property insurance upon the entire Work at the site to the full insurable value thereof. This insurance shall include the interests of the City, the Contractor, Subcontractors and Sub-subcontractors in the Work and shall insure against the perils of Fire, Extended Coverage, Vandalism and Malicious Mischief.

10.1.2 The Contractor shall purchase and maintain such steam, boiler and machinery insurance as may be required by the Contract Documents or by law. This insurance shall include the interests of the City, the Contractor, Subcontractors and Sub-subcontractors in the Work.

10.1.3 Certificates of Insurance acceptable to the City shall be filed with the City prior to commencement of the work. Certificates of Insurance must state on the certificate: **"The City of Clayton, its officers, boards, board members, commissions, commissioners, agents, and employees as additional insureds."** These Certificates shall contain a provision that coverages afforded under the policies will not be cancelled until at least fifteen days' prior written notice has been given to the City.

10.1.4 Any loss insured by property insurance maintained by the City shall be adjusted with the City and made payable to the City as trustee for the insureds, as their interests may appear, subject to the requirements of any applicable mortgage clause.

10.1.5 The City and Contractor waive all rights against each other for damages caused by fire or other perils to the extent covered by insurance provided under this Article, except such rights as they may have to the proceeds of such insurance held by the City as trustee. The Contractor shall require similar waivers by Sub-contractors and Sub-subcontractors in accordance with Subparagraph 4.3.1.

ARTICLE 11 - CHANGES IN THE WORK

11.1 CHANGE ORDERS

11.1.1 The City, without invalidating the Contract, may order Changes in the Work within the general scope of the Contract consisting of additions, deletions or other revisions, with the Contract Sum and the Construction Schedule being adjusted in accordance with the City-Contractor Agreement. All such changes in the Work shall be authorized by Change Order, and shall be executed under the applicable conditions of the Contract Documents.

11.1.2 A Change Order is a written order to the Contractor signed by the City, issued after the execution of the Contract, authorizing a change in the Work or an adjustment in the Contract Sum or the Construction Schedule. The Contract Sum and the Contract Time may be changed only by Change Order.

11.1.3 The cost or credit to the City resulting from a Change in the Work shall be determined in accordance with the City-Contractor Agreement.

11.2 CLAIMS FOR ADDITIONAL COST

11.2.1 If the Contractor wishes to make a claim for an increase in the Contract Sum, he shall give the City written notice thereof within twenty (20) days after the occurrence of the event giving rise to such claim. This notice shall be given by the Contractor before proceeding to execute the Work. No such claim shall be valid unless so made. Any change in the Contract Sum resulting from such claim shall be authorized by Change Order.

11.3 MINOR CHANGES IN THE WORK

11.3.1 The City shall have authority to order minor changes in the Work not involving an adjustment in the Contract Sum or the Construction Schedule and not inconsistent with the intent of the Contract Documents. Such changes may be effected by written Field Order or by other written order. Such changes shall be binding on the City and the Contractor.

ARTICLE 12 - UNCOVERING AND CORRECTION OF WORK

12.1 UNCOVERING OF WORK

12.1.1 If any Work should be covered contrary to the request of the City, it must, if required by the City, be uncovered for his observation and replaced, at the Contractor's expense.

12.1.2 If any Work has been covered which the City has not specifically requested to observe prior to being covered, the City may request to see such Work and it shall be uncovered by the Contractor. If such Work is found to be in accordance with the Contract Documents, the Cost of uncovering and replacement shall, by appropriate Change Order, be charged to the City. If such Work be found not in accordance with the Contract Documents, the Contractor shall pay such costs.

12.2 CORRECTION OF WORK

12.2.1 The Contractor shall promptly correct all Work rejected by the City as defective or as failing to conform to the Contract Documents, whether observed before or after substantial completion of the Work, and whether or not fabricated, installed or completed. The Contractor shall bear all cost of correcting such rejected Work.

12.2.2 If, within one year after the Date of Substantial Completion of the Work or within such longer period of time as may be prescribed by law or by the terms of any applicable special guarantee required by the Contract Documents, any of the Work is found to be defective or not in accordance with the Contract Documents, the Contractor shall correct it promptly after receipt of a written notice from the City.

12.2.3 All defective or non-conforming Work shall be removed from the site if necessary, and the Work shall be corrected to comply with the Contract Documents without additional cost to the City.

12.2.4 The Contractor shall bear the cost of making good all work of separate contractors destroyed or damaged by such removal or correction.

12.2.5 If the Contractor fails to correct such defective or non-conforming Work, the City may correct it in accordance with Paragraph 2.3.

12.3 ACCEPTANCE OF DEFECTIVE OR NON-CONFORMING WORK

12.3.1 If the City prefers to accept defective or non-conforming Work, City may do so instead of requiring its removal and correction, in which case a Change Order will be issued to reflect an appropriate reduction in the Contract Sum or, if the amount is determined after final payment, it shall be paid by the Contractor.

ARTICLE 13 - MISCELLANEOUS PROVISIONS

13.1 SCHEDULING OF WORK AND INTERFERENCE WITH TRAFFIC

13.1.1 The Contractor's Work must be scheduled and accomplished in stages such that local traffic is maintained during construction. It shall be the Contractor's responsibility to provide a traffic

way that is usable in all weather conditions. The Contractor shall construct and maintain in a safe condition temporary pavements and connections for local traffic.

13.1.2 Temporary guardrail, or other suitable temporary barriers shall be provided to protect traffic from the Work. At all times until final acceptance of the Work, the Contractor shall provide and maintain such signs, lights, watchmen and barriers, in addition to the temporary guardrail, as may be necessary to properly protect the Work and provide for safe and convenient public travel.

13.1.3 No additional payment shall be made for temporary guardrail, barriers, signs, lights, or other work as may be necessary to maintain traffic and to protect the work and the public and all labor, equipment and material necessary to accomplish this task shall be considered incidental

13.2 ACCESS

13.2.1 Areas of intersections and roadways within the construction limits shall be constructed in phases so that at no time will access be denied.

13.2.2 Access to private driveways will be limited by the nature of the Work. The Contractor shall schedule his work such that at no time during the life of this Contract will any driveway be denied access for any reason other than the curing of concrete. All concrete, including curbs, sidewalks and driveway pavements, shall be formed and poured within a two calendar day period for each and every driveway. Excavation for this work shall be accomplished a maximum of one calendar day prior to forming, however, access shall be provided immediately after excavation. At the end of the curing period, access shall be immediately supplied using asphalt or compacted aggregate. The first lift of all asphalt drives shall be completed and paved within fourteen (14) calendar days of their excavation.

13.2.3 All temporary materials used for access will be the responsibility of the Contractor and shall be included in the unit bid price for each related item. No separate payment will be made for the placement, maintenance or removal of said access.

13.2.4 If access is not supplied as set out above, the City will supply said access with its own forces, without notification to the Contractor, and will deduct such costs from the sums due the Contractor, notwithstanding any other provisions given this Contract. Wherever excavation affects pedestrian access to houses or public buildings, plank or other suitable bridges shall be placed at convenient intervals.

13.2.5 In the event any part of the Work to be performed hereunder shall require the Contractor or his Subcontractors to enter, cross or work upon or beneath the right-of-way or other property of a railroad, the Contractor shall comply with the related requirements for such Work as are set out in the Contract Documents.

13.3 CONSTRUCTION STAKING AND LAYOUT

13.3.1 The Contractor shall be responsible for providing labor, equipment and materials necessary for construction staking and layout as required, to the grades, elevations and alignment as determined by the City of Clayton. No separate payment will be made for construction staking and layout. No payment shall be made for restaking except as expressly authorized due to changes made by the City during construction.

13.4 OVERTIME

13.4.1 In order to provide sufficient control of work, the Contractor shall be required to inform the City of scheduled overtime work, including work on Saturdays, Sundays and City holidays at least forty-eight (48) hours in advance of any such work. If the Contractor fails to appear on a scheduled overtime period, the City shall deduct the cost for the City's assigned personnel from the Contract Sum for the time period scheduled.

13.5 CITY HOLIDAYS

13.5.1 There are eleven (11) city holidays. They are:

New Year's Day	July 4 th
Martin Luther King, Jr. Day	Labor Day
Thanksgiving Day	Day after Thanksgiving
President's Day	Christmas Eve
Memorial Day	Christmas Day
Juneteenth	

13.6 [Intentionally Left Blank]

13.7 INTERFERENCE WITH EXISTING WATER SERVICES AND MAINS

13.7.1 The Contractor shall minimize the outage of water service to residents. The cutting off of water service shall be only with the consent of the City. The Contractor shall notify the City and have their approval prior to commencing work on each water main or connection item.

13.7.2 The Contractor shall conduct his work in such a manner as not to endanger existing water mains, services or appurtenances. Mains and services shall be adequately supported where they cross or are adjacent to the excavation. The Contractor shall bear the cost of all repairs to water mains or appurtenances damaged because of contractor's own carelessness or neglect.

13.8 INTERRUPTION OF WATER SERVICE

13.8.1 When it becomes necessary to shut down any existing water main or service, a representative of the City shall be notified to be present during this operation. The total time for the main to be shut down should be held to a minimum and in no case shall any customer be without water service for more than eight (8) hours. The Contractor shall notify each water customer whose water service will be interrupted at least one hour prior to shutdown. The Contractor shall assume full responsibility for shutting down the main and notifying the customers.

13.9 PRECONSTRUCTION CONFERENCE

13.9.1 A preconstruction conference may be held prior to the issuance of a Notice to Proceed with the Work. This meeting will be attended by the Contractor, the City, and representatives of the various utility companies that have facilities in the project area. The meeting date will be established after the taking of bids and at a time convenient to all parties.

13.10 SEQUENCE OF WORK

13.10.1 A schedule of the Contractor's work shall be submitted to the City for approval with a listing of the order in which the Contract items will be constructed and the approximate dates for starting and finishing each Contract item.

13.10.2 The City shall have the right to specify the order of construction as deemed necessary.

13.11 CONSTRUCTION LIMITS

13.11.1 The construction limits consist of the public street rights-of-way and acquired easement areas. The Contractor shall limit operations accordingly. The Contractor shall acquire the property owners' permission for any activity outside the public right-of-way or easement areas.

13.12 ALTERED QUANTITIES

13.12.1 In accordance with Section 109.3 of the Standard Specifications, the City reserves the right to make changes in plan details which may vary the accepted quantities from those shown on the itemized Bid.

13.12.2 The Contractor shall accept, as payment in full, payment at the original Contract unit prices bid for the accepted quantities of work done. No allowance will be made for any increased expense or loss of expected profit suffered by the Contractor resulting directly from such altered quantities or indirectly from expenses derived by handling small quantities of materials or performing operations within restricted areas. No allowance shall be made for any increased expense or loss of expected profit suffered because of the anticipated use of specific equipment that was not used.

13.13 MEASUREMENT OF WEIGHED QUANTITIES

13.13.1 The Contractor's attention is directed to the fact that the City requires that all weight certificates be signed by a bonded Weighmaster. The Contractor must furnish the City's inspector on the job site with original weight certificates signed by a bonded Weighmaster for all materials supplied by the Contractor that are incorporated into his improvement, which payment therefore is based on weight.

13.14 ADDITIONS TO CONTRACT

13.14.1 Unit prices in this Agreement may be used to negotiate a Change Order for additional work involving similar projects.

13.15 PURCHASE OF MATERIALS AND EQUIPMENT

13.15.1 Sales to contractors who purchase construction materials and supplies to fulfill contracts for the City are not subject to sales tax. The City may monitor all supplies purchased, used, and consumed in fulfilling the project.

13.15.2 Contractors will be give a project exemption certificate.

13.15.3 Contractors must provide a copy of the City's exemption letter and the project exemption certificate to suppliers when purchasing materials and supplies to be consumed in the project.

13.15.4 Contractors are not exempt from sales tax on the purchase of machinery, equipment or tools used in fulfilling these contracts.

13.15.5 Suppliers shall render to the contractor invoices bearing the name of the City and the project identification number. These invoices must be retained by the purchasing contractor for a period of five (5) years.

13.15.6 Contractors must file a sales tax return for all excess re-saleable materials and supplies that are not returned to the supplier. This return must be filed and paid not later than the due date of the contractor's sales tax return following the month in which the contractor determines that the materials were not used in the project.

13.15.7 An exempt organization that fails to revise the project exemption certificate expiration date as necessary to complete any work required by the contract will be liable for any sales tax due as determined by an audit of the contractor.

13.16 TESTING

13.16.1 Materials Testing and Inspection Service: City may employ and pay for a qualified independent materials and geotechnical testing laboratory to perform testing and inspection service during construction operations. Contractor to coordinate all work.

13.16.2 The Contractor shall bear all costs of any inspections, tests, or approvals required under any laws, ordinances, rules, regulations or orders of any public authority having jurisdiction.

13.16.3 The City will provide any special inspection and testing services to verify the Work is performed in accordance with the Contract. The City will provide the Contractor with a listing of tests to be performed and approximate location or frequency. The Contractor will be required to notify the City forty-eight (48) hours prior to the time the Contractor will be ready for specific tests required by the City. If such special inspection or testing reveals failure of the Work to comply (1) with the requirements of the Contract Documents, or (2) with respect to the performance of the Work, with laws, ordinances, rules, regulations or orders of any public authority having jurisdiction, the Contractor shall bear the cost of the City's inspection and re-testing and such cost shall be deducted then or thereafter due Contractor. In all other cases, the City shall bear such costs.

13.17 SEWER SPECIFICATIONS

13.17.1 The Metropolitan St. Louis Sewer District Specifications (MSD Specifications), shall govern the Project, unless otherwise superseded by the Technical Specifications and Job Special Provisions.

13.18 CONTROL OF MATERIAL

13.18.1 All tickets will be collected to verify the quantity of each item in their original form only. Photocopies or facsimiles will not be accepted. All tickets shall be submitted on the day of delivery, either to the City personnel or the Public Works office or they will not be accepted for payment.

13.18.2 Contractors and subcontractors will be required to produce letters of certification or certified test reports from material producers and suppliers in order to determine compliance with specifications for designated materials prior to the incorporation thereof into the work.

13.18.3 The City will determine which materials are to be tested. The form and content of these test reports shall be in accordance with recognized standards and practices for this work or as otherwise determined by the City.

13.18.4 No direct payment will be made for this work.

13.19 MEASUREMENT OF QUANTITIES

13.19.1 Unless otherwise directed within the Technical Specifications, the quantities for which payment will be made will be those shown in the Agreement for the various items, provided the Project is constructed essentially to the lines and grades shown on the plans. Contract quantities will be used for final payment except when:

- a) Errors are formed in the original computations in excess of 15% of the contract quantities.
- b) An original cross section is found to have an average deviation from the true elevation in excess of one foot.
- c) An authorized change in grade, slope or typical section is made.
- d) Unauthorized deviations decrease the quantities on the plans.

When the above conditions are encountered, the correction or revisions will be computed and added to or deducted from the contract quantity.

13.19.2 When the plans have been altered or when disagreement exists between the Contractor and the City as to the accuracy of the plan quantities of any balance, or the entire project, either party shall have the right to request a re-computation of contract quantities within any area, by hand calculation of the average-end-area method for cubic yard quantities, and standard measurement methods for other quantities, by written notice to the other party. The written notice shall contain evidence that an error exists in the original groundline elevation or in the original computations which will affect the final payment quantity in excess of 15%. When such final measurement is required, it will be made from the latest available ground surface and the design section.

13.19.3 These specifications require that the Contractor must furnish the representative of the City, on the job site, with original weight certificates on a daily basis signed by a bonded weighmaster for all materials supplied by the Contractor that are incorporated into this work, which payment therefore is based on weight.

13.20 WORKMANSHIP

13.20.1 The Contractor shall at all times employ sufficient labor and equipment for prosecuting the work to full completion in the manner and time required by these specifications. All workmen shall have sufficient skill and experience to perform properly the work assigned to them.

13.20.2 The labor provided by the Contractor shall be directed to be of a workmanlike character with respect to the methods of construction and quality of completed work; and, shall not encumber the premises or adjacent property or streets with materials and/or equipment.

13.20.3 "Removal" shall be defined as removal and disposal off the site unless otherwise specified or directed by the engineer.

ARTICLE 14 - EQUAL OPPORTUNITY AND NON-DISCRIMINATION

14.1 EQUAL OPPORTUNITY

14.1.1 The contractor, with regard to the work performed by it after award and prior to completion of the Work, will not discriminate on the basis of race, age, color, religion, sex, national origin or disability in the selection and retention of subcontractors. The contractor will comply with Title VII of the Civil Rights Act of 1964, as the same has been or may be amended from time to time. In all solicitation either by competitive bidding or negotiations made by the contractor for work to be performed under a subcontract, including procurement of materials or equipment, each potential subcontractor or supplier shall be notified of the contractor's obligations under this contract and the regulations relative to nondiscrimination on the ground of race, color, age, religion, sex, national origin or disability.

14.1.2 The contractor will take action to ensure that applicants are employed and that employees are treated during employment without regard to their race, age, color, religion, sex, national origin or disability. Such action shall include, but not be limited to the employment, upgrading, demotion or transfer, recruitment or recruitment advertising, layoff or termination, rates of pay or other forms of compensation, and selection for training including apprenticeship. The contractor agrees to post notices pertaining to the foregoing in conspicuous places available to employees and applicants for employment.

14.1.3 The contractor will, in all solicitations or advertisements for employees placed by or on behalf of the contractor, state that all qualified applicants will receive consideration for employment without regard to race, color, age, religion, sex, national origin or disability.

14.1.4 The contractor will comply with all provisions of federal, state and local codes, ordinances and regulations governing the regulation of Equal Employment Opportunity and Non-Discrimination.

14.2 NON-DISCRIMINATION

14.2.1 During performance of the obligations set forth in this Agreement, Contractor agrees that it shall not discriminate against any employee or applicant for employment in the terms or conditions of employment including but not limited to: recruitment, selection, training, upgrading, promotion, demotion, transfer, layoff, or termination due to said person's race, religion, creed, color, sex, age, national origin, handicap, or disability.

14.3 GENERAL

14.3.1 In the event that any or all of the provision(s) of the foregoing paragraphs conflict with federal, state or other local laws, ordinances or regulations, then the requirements of such federal, state or local laws, ordinances, or regulations shall prevail. Compliance with the foregoing provisions shall not relieve the contractor from adherence to any and all additional requirements regarding equal

employment or non-discrimination set forth in such federal, state or other local laws, ordinances or regulations.

ARTICLE 15 - CONFLICTS OF INTEREST

15.1.1 The parties agree to abide by all applicable federal, state and local laws, ordinances and regulations relating to conflicts of interest. Additionally, but not in limitation of the foregoing, no elected official or other official of Clayton having any power of review or approval of any of the undertakings contemplated by this Agreement, shall knowingly participate in any decision(s) relating thereto which affect his or her personal interests or those of his/her immediate family, or those of any corporation or partnership in which he or she or a member of his/her immediate family is directly or indirectly interested.

15.1.2 Clayton shall not knowingly, after due inquiry, employ or contract with any person if a member of his or her immediate family is a member of the Clayton Board of Aldermen, or is employed by Clayton in an administrative capacity (i.e., those who have selection, hiring or supervisory or operational responsibility for the work to be performed pursuant to this Agreement); provided, however, that the foregoing shall not apply to temporary or seasonal employment. Clayton shall not knowingly, after due inquiry, employ or contract with any corporation or partnership if an elected official of Clayton or a person employed by Clayton in an administrative capacity (as defined in the foregoing sentence), or a member of the immediate family of such elected official or person employed in an administrative capacity shall have an interest, directly or indirectly, therein.

15.1.3 For the purposes of this section "immediate family" includes: husband, wife, son, daughter, father, mother, brother, sister, brother-in-law, sister-in-law, father-in-law, mother-in-law, uncle, aunt, nephew, niece, step-parent and step-child.

15.1.4 For purposes of this section, a person shall be deemed to have an interest in a corporation or partnership if he or she, or any member of his/her immediate family shall own, whether singularly or collectively, directly or indirectly, ten percent (10%) more of any corporation or partnership, or shall own an interest having a value of ten thousand dollars (\$10,000) or more therein, or an individual or a member of his/her immediate family shall receive, whether singularly or collectively, directly or indirectly, of a salary, gratuity, or other compensation or remuneration of five thousand dollars (\$5,000) or more per year therefrom.

15.1.5 In the event that any or all of the foregoing provision(s) shall conflict with federal, state or other local laws, ordinances or regulations, then the requirements of such federal, state or local laws, ordinances, or regulations shall prevail. Compliance with the foregoing provisions shall not relieve parties contracting with the City of Clayton from adherence to any and all additional requirements regarding conflicts of interest set forth in such federal, state or other local laws, ordinances or regulations.

ARTICLE 16 – ALIEN REGISTRATION, COMPLIANCE AND ENFORCEMENT

16.1 DEFINITIONS

16.1.1 "Business entity", any person or group of persons performing or engaging in any activity, enterprise, profession, or occupation for gain, benefit, advantage, or livelihood. The term "business entity" shall include but not be limited to self-employed individuals, partnerships, corporations, contractors, and subcontractors. The term "business entity" shall include any business entity that

possesses a business permit, license, or tax certificate issued by the state, any business entity that is exempt by law from obtaining such a business permit, and any business entity that is operating unlawfully without such a business permit. The term "business entity" shall not include a self-employed individual with no employees or entities utilizing the services of direct sellers as defined in subdivision (17) of subsection 12 of section 288.034, RSMo;

16.1.2 "Contractor", a person, employer, or business entity that enters into an agreement to perform any service or work or to provide a certain product in exchange for valuable consideration. This definition shall include but not be limited to a general contractor, subcontractor, independent contractor, contract employee, project manager, or a recruiting or staffing entity;

16.1.3 "Employee", any person performing work or service of any kind or character for hire within the state of Missouri;

16.1.4 "Employer", any person or entity employing any person for hire within the state of Missouri, including a public employer. Where there are two or more putative employers, any person or entity taking a business tax deduction for the employee in question shall be considered an employer of that person for purposes of this section;

16.1.5 "Employment", the act of employing or state of being employed, engaged, or hired to perform work or service of any kind or character within the state of Missouri;

16.1.6 "Federal work authorization program", any of the electronic verification of work authorization programs operated by the United States Department of Homeland Security or an equivalent federal work authorization program operated by the United States Department of Homeland Security to verify information of newly hired employees, under the Immigration Reform and Control Act of 1986 (IRCA), P.L.99-603;

16.1.7 "Knowingly", a person acts knowingly or with knowledge,
(a) With respect to the person's conduct or to attendant circumstances when the person is aware of the nature of the person's conduct or that those circumstances exist; or
(b) With respect to a result of the person's conduct when the person is aware that the person's conduct is practically certain to cause that result;

16.1.8 "Municipality", the City of Clayton, Missouri.

16.1.9 "Public employer", every department, agency, or instrumentality of the state of Missouri or any political subdivision of the state of Missouri;

16.1.10 "Unauthorized alien", an alien who does not have the legal right or authorization under federal law to work in the United States, as defined in 8 U.S.C. 1324a(h)(3);

16.1.11 "Work", any job, task, employment, labor, personal services, or any other activity for which compensation is provided, expected or due, including but not limited to all activities conducted by business entities.

16.2 ILLEGAL ACTS

16.2.1 No business entity or employer may knowingly employ, hire for employment, or continue to employ an unauthorized alien to perform work within the municipality.

16.2.2. Accordingly, if the amount to be paid pursuant to this contract or grant exceeds five thousand dollars by the municipality the contracting or grant recipient business entity shall, as a condition of the award of contract or grant, by sworn affidavit and provision of documentation, affirm its enrollment and participation in a federal work authorization program with respect to the employees working in connection with the contracted services. Every such business entity shall also sign an affidavit affirming that it does not knowingly employ any person who is an unauthorized alien in connection with the contracted services. No such business entity or employer shall violate subsection 16.2.1 of this section.

16.2.3 The affidavit shall be approved as to form by the municipal attorney.

16.2.4 An employer may enroll and participate in a federal work authorization program and shall verify the employment eligibility of every employee in the employer's hire whose employment commences after the employer enrolls in a federal work authorization program. The employer shall retain a copy of the dated verification report received from the federal government. Any business entity that participates in such program shall have an affirmative defense that such business entity has not violated subsection 16.2.1 of this section.

16.2.5 A general contractor or subcontractor of any tier shall not be liable under subsection 16.2.1 of this section when such general contractor or subcontractor contracts with its direct subcontractor who violates subsection 16.2.1 of this section, if the contract binding the contractor and subcontractor affirmatively states that the direct subcontractor is not knowingly in violation of subsection 16.2.1 of this section and shall not henceforth be in such violation and the contractor or subcontractor receives a sworn affidavit under the penalty of perjury attesting to the fact that the direct subcontractor's employees are lawfully present in the United States.

16.2.6 The determination of whether a worker is an unauthorized alien shall be made by the federal government. A determination of such status of an individual by the federal government shall create a rebuttable presumption as to that individual's status in any judicial proceedings brought under this section.

ARTICLE 17 – SAFETY PROGRAMS, COMPLIANCE AND PENALTIES

17.1 DEFINITIONS

17.1.1 "Construction", construction, reconstruction, demolition, painting and decorating, or major repair;

17.1.2 "Department", the Missouri department of labor and industrial relations;

17.1.3 "Person", any natural person, joint venture, partnership, corporation, or other business or legal entity;

17.1.4 "Municipality", the City of Clayton, Missouri;

17.1.5 "Public works", all fixed works constructed for public use or benefit or paid for wholly or in part out of public funds.

17.2 OSHA 10-HOUR TRAINING

17.2.1 Any person signing a contract to work on the construction of public works for the municipality shall provide a ten-hour Occupational Safety and Health Administration (OSHA) construction safety program for their on-site employees which includes a course in construction safety and health approved by OSHA or a similar program approved by the department which is at least as stringent as an approved OSHA program. All employees are required to complete the program within sixty days of beginning work on such construction project.

17.3 DOCUMENTATION

17.3.1 Any employee found on a worksite subject to this section without documentation of the successful completion of the course required under subsection 17.2.1 of this Article shall be afforded twenty days to produce such documentation before being subject to removal from the project.

17.4 PENALTIES

17.4.1 The contractor to whom the contract is awarded and any subcontractor under such contractor shall require all on-site employees to complete the ten-hour training program required under subsection 2 of this section. The contractor shall forfeit as a penalty to the municipality, two thousand five hundred dollars plus one hundred dollars for each employee employed by the contractor or subcontractor, for each calendar day, or portion thereof, such employee is employed without the required training. The penalty shall not begin to accrue until the time period in subsections 2 and 3 of this section have elapsed. The municipality shall withhold and retain therefrom, all sums and amounts due and owing as a result of any violation of this section when making payments to the contractor under the contract. The contractor may withhold from any subcontractor, sufficient sums to cover any penalties the public body has withheld from the contractor resulting from the subcontractor's failure to comply with the terms of this section. If the payment has been made to the subcontractor without withholding, the contractor may recover the amount of the penalty resulting from the fault of the subcontractor.

17.5 INVESTIGATION

17.5.1 In determining whether a violation of this section has occurred, and whether the penalty under subsection 4 of this section shall be imposed, the department shall investigate any claim of violation. Upon completing such investigation, the department shall notify the municipality and any party found to be in violation of this section of its findings and whether a penalty shall be assessed. Determinations under this section may be appealed in the Circuit Court of St. Louis County.

17.6 ENFORCEMENT

17.6.1 If the contractor or subcontractor fails to pay the penalty within forty-five days following notification by the department, the department shall pursue an enforcement action to enforce the monetary penalty provisions of subsection 4 of this section against the contractor or subcontractor found to be in violation of this section. If the court orders payment of the penalties as prescribed under subsection 4 of this section, the department shall be entitled to recover its actual cost of enforcement in addition to such penalty amount.

ARTICLE 18 - TRANSIENT EMPLOYERS

18.1 REQUIREMENTS

18.1.1 Per RSMo section 285.234, every transient employer, as defined in section 285.230 shall post in a prominent and easily accessible place at the work site a clearly legible copy of the following:

18.1.1.1 The notice of registration for employer withholding issued to such transient employer by the director of revenue;

18.1.1.2 Proof of coverage for workers' compensation insurance or self-insurance signed by the transient employer and verified by the department of revenue through the records of the division of workers' compensation; and

18.1.1.3 The notice of registration for unemployment insurance issued to such transient employer by the division of employment security.

18.2 ENFORCEMENT

18.2.1 Any transient employer failing to comply with the provisions of this section shall be liable for a penalty of five hundred dollars per day until the notices required by this section are posted as provided by this section.

CONTRACTOR’S AFFIDAVIT FOR PUBLIC CONSTRUCTION PROJECTS

The undersigned, being duly sworn, does state and depose as follows:

1. I am the _____(title) of _____(company) which is a contractor on the _____ Project, and authorized to sign this Affidavit on the Company’s behalf.

2. I have verified the information set forth in this Affidavit for the Contractor. If any subcontractors have been retained on the Project, I have also verified the information as to any subcontractor.

3. The Contractor and its subcontractors have Workers’ Compensation Insurance that covers its employees working on the Project and such insurance meets or exceeds the requirements established by law.

4. The Contractor and its subcontractors have verified the U.S. citizenship or lawful status of all workers employed on the Project and do not knowingly employ any person who is an unauthorized alien in connection with the contracted services.

5. The Contractor and its subcontractors have been informed by the City of the requirements to pay prevailing wage and will pay the prevailing wages to all workers employed on the Project as established by the applicable Annual Wage Order for the County where the Project occurs.

6. The Contractor and its subcontractors are in compliance with federal law requiring an accredited apprenticeship program, if applicable.

7. The Contractor and its subcontractors are enrolled and participate in a federal work authorization program with respect to employees working in connection with the contracted services.

Further Affiant sayeth naught.

Authorized Officer of Contractor

Subscribed and sworn to before me this ____ day of _____, 20 ____.

Notary Public
My commission expires:_____

JOB SPECIAL PROVISIONS – TABLE OF CONTENTS

(Job Special Provisions shall prevail over Specification and/or General Conditions whenever in conflict therewith)

The Standards Specifications for Construction of the Clayton CBD Resurfacing – Phase 1 Project shall be applicable sections of the 2022 St. Louis County Standard Specifications for Road and Bridge Construction. Items not covered by St. Louis County Standard Specifications shall follow the 2022 Missouri Standards Specifications Book for Highway Construction. These specifications shall govern all improvement work contained in this project and shown on the plans, unless otherwise noted.

The Standards Specifications for Construction of all sewer work shall be applicable sections of the Standard Construction Specification for Sewer and Drainage Facilities 2009 Metropolitan St. Louis Sewer District. This specification shall govern all improvement work contained in this project and shown on the plans.

- | | |
|---|---|
| A. Definitions | Q. Variable Height Trench Drain System |
| B. Project Contact for Contractor / Bidder Questions | R. Concrete Curb And Gutter, Type A (8 In.) |
| C. Modification to Measurement and Payment | S. Roadway Signs |
| D. Special Requirements | T. Pavement Markings and Symbols |
| E. Traffic Control (During Construction) | U. Concrete Sidewalks, Curb Ramps, and Detectable Warning Surface |
| F. Utilities | V. Brick Paver Crosswalk |
| G. Removal of Improvements | W. PCC Base for Concrete Pavers |
| H. Concrete Base (8", Non-Reinforced) | X. Brick Pavers Carriage Strip |
| I. Adjust Utility Service or Facility to Grade | Y. New Stanchion Post (Includes Base) |
| J. Equipment and/or Material Storage Area | Z. Sign Relocations |
| K. Removal and Salvage of City Signs | AA. Wireless Traffic Sensors |
| L. Aggregate Base Course | BB. ADA Compliance and Final Acceptance of Constructed Facilities |
| M. Superpave Asphalt | CC. LPA Buy America Requirements |
| N. High Tensile Strength Synthetic Fibers For Asphalt | DD. Add Alternate |
| O. Echelon Paving Requirement | EE. MoDOT Supplemental Revisions |
| P. Use of Meramec Sand and Gravel in Concrete | FF. Emulsified Maltene-Based Rejuvenator |

The responsibility of the undersigned Professional Engineer is limited to the Job Special Provisions contained herein. The Professional Engineer disclaims any responsibility for other documents, including which do not bear his/her seal and signature.

A. DEFINITIONS

1.0 The March 15, 2022 edition of the St. Louis County Standard Specifications for Road and Bridge Construction as published by the St. Louis County Department of Transportation (SLCDOT) shall be referred to as the PRIMARY technical specifications for the project. These specifications are available online at www.stlouisco.com.

1.1 The current edition of the City of Clayton’s Technical Specifications, attached herein to the Contract Documents, have, for the purpose of this contract, been adopted as the SECONDARY specifications.

1.2 If a bid item is neither identified within the Job Special Provisions, nor the St. Louis County Standard Specifications for Road and Bridge Construction, the 2022 edition of the Missouri Department of Transportation (MoDOT) Standard Specifications for Highway Construction shall be used for specifications, construction requirements, measurement and pay.

1.3 Storm Sewer System and Appurtenances. The 2009 edition of the Standard Construction Specifications for Sewers and Drainage Facilities as published by the Metropolitan St. Louis Sewer District, St. Louis, Missouri, have, for the purpose of this contract, been adopted as the technical specifications.

2.0 Unless otherwise stated, all references to “plans” refer to the construction plans provided with this contract.

3.0 Whenever the phrases or words “Missouri or St. Louis County Department of Transportation”, “MoDOT”, “St. Louis County”, or “State or County” appear in the Standard Specifications or the Job Special Provisions, both the phrases and the words shall be construed signifying the “City of Clayton” acting through the Board of Aldermen.

4.0 Whenever the phrases or words “Chief Engineer,” “Engineer,” or “Director” appear in the Standard Specifications and the Job Special Provisions, both the phrases and the words shall be construed as signifying the “City of Clayton.”

5.0 Whenever the words “State”, “City”, or “County” appear in the Standard Specifications and the Job Special Provisions, they shall be construed as signifying the “City of Clayton.”

B. PROJECT CONTACT FOR CONTRACTOR / BIDDER QUESTIONS

1.0 All questions concerning this project shall be forwarded to the project contacts listed below.

Brady Jordan, P.E
Horner & Shifrin, Inc.
401 S. 18th St., Ste. 400
St. Louis, MO 63103
Telephone Number: 314-335-8661
Email: bsjordan@hornershifrin.com

All questions concerning the bid document preparation can be directed to Rich Wilburn, Assistant

Director of Public Works, at 314-290-8565. Project specific questions can be directed to Brady Jordan, Principal Engineer, Horner & Shifrin at 314-335-8661.

C. MODIFICATION TO MEASUREMENT AND PAYMENT

1.0 General. The total Contract Price shall cover all Work required by the Contract Documents. All costs in connection with the proper and successful completion of the Work, including furnishing all materials, equipment, supplies, and appurtenances; providing all construction plant, equipment, and tools; and performing all necessary labor and supervision to fully complete the Work, shall be included in the unit and lump sum prices bid. All Work not specifically set forth as a pay item in the Bid Form shall be considered a subsidiary obligation of CONTRACTOR and all costs in connection therewith shall be included in the prices bid.

2.0 Estimated Quantities. All estimated quantities stipulated in the Bid Form or other Contract Documents are approximate and are to be used only (a) as a basis for estimating the probable cost of the Work and (b) for the purpose of comparing the bids submitted for the Work. The actual amounts of work done and materials furnished under unit price items may differ from the estimated quantities. The basis of payment for work and materials will be the actual amount of work done and material furnished. CONTRACTOR agrees that it will make no claim for damages, anticipated profits, or otherwise on account of any difference between the amounts of work actually performed and material actually furnished and the estimated amounts.

3.0 Incidentals. There will be no direct pay for the minimum following items, or any other items not specifically identified within these plans and specifications:

- (a) Granular Backfill
- (b) Full Depth Sawcutting
- (c) Irrigation Removal/Repair
- (d) Special Requirements
- (e) Resident Notification
- (f) Boneyard or laydown area
- (g) Site maintenance
- (h) Job Special Provisions, unless otherwise noted

D. SPECIAL REQUIREMENTS

CONTRACTOR'S WORK SCHEDULE

General: In all cases, the contractor shall notify the City Engineer, sufficiently in advance of operations, in order to provide for suitable inspection of the preparation work performed by the

Contractor. In no case shall the Contractor be permitted to begin operations without prior approval by the City Engineer. The City is to be contacted at the following phone number:

City of Clayton Public Works Department (314) 290-8540

Work Hours: Clayton noise ordinance dictates work hours of 7am – 6pm to comply with ordinance. Unless otherwise approved by the City Engineer, Central Business District lane drops can only occur between 9:00 AM and 4:00 PM due to high traffic volumes.

Schedule: It is expected that Notice to Proceed will be issued by November 15, 2023 and paving operations will take place in 2024. The contractor will need to prioritize and coordinate paving areas to be completed near schools during the summer months when school is not in session. The contractor will also need account for the schedule city events included in this bid package

Due to the high volume within the Central Business District, it is expected that paving operations will take place overnight or on weekends as approved by the City. Temporary pavement markings shall be installed prior to the roadway opening. No separate payment shall be made for temporary pavement markings.

Staging: Contractor shall schedule work in a manner to account for pedestrian routes and on street parking needs of the area. In cases where multiple streets are being paved the contractor shall allow for on-street parking on neighboring streets (i.e. do not pave more than 2 consecutive streets without allowing an open street for parking). Contractor shall submit a paving sequence plan with the construction schedule. Paving phasing plan shall be developed with input from City and shall be establish in a manner to maintain emergency vehicle access and minimize detours. Care shall be taken to avoid putting equipment/trucks on newly paved roads.

NOTIFICATION OF BUSINESSES / RESIDENTS

General: If affecting access to a business, the contractor will be required to notify property owners and business owners adjacent to the affected sidewalk 24 hours prior to any work being done and make every effort to maintain access at all times the business is open.

Notification of Businesses / Residents: The contractor will be required to notify property owners and business owners adjacent to the effected roadways prior to any work being done. The City Engineer shall approve the letter prior to distribution. The contractor shall mail or hand-deliver the letters at least one (1) week, but not more than one (1) month, prior to work beginning in each phase area. If the paving phase begins 6 weeks or more after the initial letter, a secondary letter shall be sent by the contractor prior to paving to notify properties. This letter shall also be approved by the City prior to distribution. **One letter per household (i.e. 6 family unit = 6 letters).**

NO PARKING SIGNS or PARKING METER HOODS

General: The contractor shall be responsible for prior notification of residents regarding no parking on streets during construction operations. Temporary "No Parking" signs clearly noting the **Day, Date and Time/Duration** (example...Monday, January 1, 7am-6pm) of construction activity shall be provided and installed at minimum intervals of 25 feet and maximum intervals of 50 feet, 48 hours in advance of work. The contractor shall notify the City when "No Parking" signs are placed or revised so that staff may document the existing conditions. **The signs will be supplied by the contractor and approved by the City Engineer. They must be thick paperboard as produced by Wazco or an approved equal.** If the area is serviced by parking meters, a parking meter rental application shall be completed by the contractor and submitted to the Public Works Dept. 48 hours prior to the request, no fee will be charged to the contractor. Public Works will provide hoods on these meters to prevent parking. This shall apply to localized parking, during paving operations the roadway will be closed and no permits will be necessary.

Installation: The contractor shall attach temporary no parking signs using plastic/wire ties or staples to trees or wooden utility poles or attach to wooden stakes supplied by contractor.

Removal: The signs will be removed and disposed of by the Contractor approximately two (2) hours after construction operations have been completed or as directed by the City Engineer.

CLEANING UP

General: The Contractor at all times shall keep the premises free from accumulation of waste materials or rubbish caused by his operations. Stormwater Erosion Best Management Practices shall be installed and maintained as necessary to minimize or eliminate site runoff.

The Contractor shall provide a restroom and trash barrel within a reasonable distance (typically 500 feet or less) of any area where work is occurring. The trash barrel will be labeled as such and emptied at least weekly. Trash left elsewhere in the work area, such as in the overdig, will not be tolerated.

When forms are being stored on grass, i.e. lying, they will be stacked on top of not more than two 4x4 inch pieces of lumber. The purpose of this lumber is to eliminate the grass being killed beneath the forms when they are being stored prior to, or following placement of concrete. If the forms are stored on pavement, the lumber is not required. Storage of the forms on sidewalks shall not be allowed. Care shall be taken to ensure that forms are not laid on sprinkler system heads.

Any soil remaining on the pavement following backfill of the overdig shall be removed within 24 hours. Barricades, which are no longer required on a street or sidewalk, shall be moved to the storage area within 24 hours of opening the pavement/sidewalk. At no time shall items stored in the right-of-way or on the pavement block the drainage of water through the area.

Concrete Truck Washout: Concrete trucks must be washed out in a manner compliant with MSD and MDNR guidelines. They can generally be washed out into areas that have been excavated in preparation for future concrete placement. If this is not an option, it is recommended that the contractor provide a dumpster lined in plastic for washout or a City approved disposal

device. At no time shall concrete washout occur on grass areas, pavement to remain in place, or in a location that drains directly into sewers.

End of Day: At the end of each work day the Contractor shall remove all remaining waste materials and rubbish from and about the project as well as all tools, construction equipment, machinery and surplus materials, and shall clean all surfaces (streets, sidewalks, curbs, tree boxes, private property, and cars) and leave the job site "broomclean" or its equivalent. **Failure to comply with this section will result in an immediate Stop Work order.**

ENCOUNTERED TREE ROOTS

General: The City shall be notified if tree roots are encountered during the course of construction that will need to be altered. The City will have a staff arborist review the situation and make recommendations on the cutting/removal of the tree roots. **Any tree roots encountered shall be saw cut vertically** and removed to a depth of 6" below the finished subgrade with the resultant excavation to be filled with a select compacted earth acceptable to the City. Removal of any tree roots shall be considered incidental and no separate payment will be made.

STORAGE OF EQUIPMENT

General: Equipment and materials shall be stored offsite unless otherwise approved by the City Engineer. The contractor may make arrangements to store equipment and materials on private property, however this shall be done in accordance with City Ordinance and is subject to approval by City Engineer.

DRIVEWAY APPROACH AND PEDESTRIAN ACCESS

General: Access to driveways will be limited by the nature of the Work. The Contractor shall schedule his work such that at no time during the life of this Contract shall any driveway be denied access for any reason other than construction activities and the curing of concrete. All concrete, including curbs, sidewalks and driveway pavements, shall be formed and poured within a two-calendar day period for each and every driveway. Excavation for this work shall be accomplished a maximum of one calendar day prior to forming, however, access shall be provided immediately after excavation.

All temporary materials used for access shall be the responsibility of the Contractor and shall be included in his unit bid price for each related item. No separate payment shall be made for the placement, maintenance or removal of said access.

If said access is not supplied as set out above, the City shall supply said access with its own forces, without notification to the Contractor, and shall deduct such costs from the sums due the Contractor, notwithstanding any other provisions given in this Contract.

Wherever excavation affects pedestrian access to houses or public buildings, plank or other suitable bridges shall be placed at appropriate intervals. No separate payment will be made for providing pedestrian access.

SPRINKLER SYSTEMS AND UNDERGROUND ELECTRIC FENCES

General: It shall be the Contractor's responsibility to repair or replace sprinkler systems and any underground electric fences that are damaged due to construction activities to the satisfaction of the City Engineer. This shall include all sprinkler systems and underground electric fences on City right-of-way and private property. The Contractor shall be required to make the necessary repairs within five (5) working days.

If said repairs are not completed as set out above, the City shall make the necessary repairs, and shall deduct the repair cost from the sums due the Contractor.

PROTECTION OF TRAFFIC SIGNAL LOOP DETECTORS

General: Traffic signal loop detectors shall be protected at all times. It is the responsibility of the contractor to locate all lines associated with the traffic loop detectors. If the contractor determines the planned improvements will conflict with traffic signal loop detectors located in the field the contractor shall notify the City prior to disturbing the traffic signal loop detectors. Any disturbance to the detector loops by the contractor, without approval from the City Engineer, shall be repaired at the sole expense of the contractor.

Replacement: If the signal loop detectors are damaged, it is the responsibility of the contractor to coordinate with the City or County and repair the damage as stipulated in the Technical Specifications within seven (7) calendar days after paving.

INSPECTION AND TESTING

General: In accordance with Section 105.13 of the St. Louis County Specifications, the Contractor is responsible for the maintenance of all items completed by him and his subcontractors until acceptance by the City of Clayton, either partial or final, as provided for in Sections 105.15.1 and 105.15.2, respectively. Maintenance shall include removal and replacement of damaged items, either existing or newly constructed, or portions of items to the extent necessary for the work to fully comply with the specifications.

Brick Paver Crosswalks: The Contractor shall at all times protect Brick Paver crosswalks located throughout the City. The Contractor shall take extra precaution to ensure that sealing material does not drip, spill, or track onto the crosswalks. Any damage caused to the crosswalks as part of this project shall be repaired at the Contractor's expense, as determined by the City Engineer.

Replacement: No direct or additional payment will be made for the cost of repair or replacement of damaged items. No adjustment in final quantities will be made.

Basis of Payment: No direct payment will be made for following these Special Requirements.

E. TRAFFIC CONTROL (DURING CONSTRUCTION)

1.0 Section 616 of the St. Louis County Standard Specification for Road and Bridges shall be amended as follows:

2.0 Description. At all times until final acceptance of the work, Contractor shall provide and maintain such signs, lights, watchmen and barriers as directed by the City Engineer. In accordance with section 104.6 of the St. Louis County Specifications, the Contractor will be required to maintain all traffic, through and local, as defined in Sections 104.6.1 and 104.6.2, respectively.

This work shall consist of furnishing, placing and maintaining flags, barricades, drums, cones and furnishing flagmen in accordance with the Manual of Uniform Traffic Control Devices, the contract, the plans, or as directed by the City Engineer.

Additional sign, barricades, or other safety devices shall be placed as directed by the City Engineer and maintained throughout the project. Other work which is necessary solely to bring the construction areas to a level of safe operation as determined by good construction practice and the City shall be included in this item.

Barricades shall have an operating, flashing warning light securely attached to each as directed by the City Engineer.

Project information signs and advance warning signs located off the project limits shall be the responsibility of the Contractor. The Contractor shall maintain traffic control devices in good condition as described for all work until acceptance by the City Engineer.

2.1 Traffic Flow: Contractor shall schedule and accomplish work in stages such that local traffic is maintained during construction. No direct payment will be made for any inconvenience or time lost because of the interference of traffic. All traffic control shall be according to the standards of the Manual on Uniform Traffic Control Devices developed by the Federal Highway Administration.

2.2 Devices: Contractor will be required to provide and install sufficient traffic control devices (i.e., orange, 42 inch tall cones, **(NO BARRELS)** to barricade alley entrances, driveways, and parking lots in each city block during operations as directed by the City Engineer. It shall be the responsibility of the Contractor to provide, install, and maintain such signs, cones, lane delineators, and other facilities that may be necessary to protect the work and provide for safe travel through the construction area. **Cones, 42 inches tall, shall be used to provide safe travel to public. NO BARRELS WILL BE PERMITTED.**

3.0 A Traffic Control Plan shall be prepared and submitted for the City's approval prior to the Preconstruction Conference. Said plan shall indicate the location of all proposed signage, the

projected work in accordance with the Manual of Uniform Traffic Control Devices. The Contractor shall not deviate from this plan without the consent of the City.

4.0 Method of Measurement. Temporary Traffic Control items will not individually be measured unless otherwise specified.

The traffic control quantities shown in the plans are based on potential closure scenarios, and shown only as a way for the Contractor to gauge needs of the Traffic Control effort.

5.0 Basis of Payment. Payment for traffic control shall be based on the percentage of the project that has been accepted by the City. The furnishing, placing and maintaining traffic control will be paid for as Channelizing Device (EACH) as well as Construction Signs (SF), MOVEABLE BARRICADES WITH MODEL "B" AMBER FLASHERS (2 EACH PER BARRICADE) (EACH), ARROW PANEL, TYPE "B" (NOISELESS), RENTAL (EACH), and CHANGEABLE MESSAGE BOARD (NOISELESS), RENTAL (EACH) and shall be full compensation for all labor, equipment, materials and incidentals necessary to provide the traffic control required for execution of the construction. No separate or additional payment will be made for moving traffic control equipment from one portion of the project to another.

5.1 No payment will be made for the relocation, movement, or replacement of any individual construction traffic staging item used for this work. This work is a roving, moving construction zone and as such, the Contractor acknowledges that relocation and re-use of items is required.

F. UTILITIES

1.0 For informational purposes only, the following is a list of names, addresses, and telephone numbers of the known utility companies in the area of the construction work for this improvement:

<u>Utility Name</u>	<u>Known Required Adjustment</u>
Spire Energy 4118 Shrewsbury Avenue St. Louis, MO 63103 Contact: Brian Langenbacher Telephone: 314-768-7767	No
AT&T 12851 Manchester Rd Des Peres, MO 63131 Contact: Terry Rodgers Telephone: 636-448-4621	No

Missouri American Water Company 727 Craig Road St.Louis, MO 63141 Contact: Priyanka Sidella Telephone: 314-343-7586	No
Charter Communications 815 Charter Commons Town & Country, MO 63017 Contact: Sue Sheldon Telephone: 314-386-1645	No
Ameren 1901 Chouteau Ave. St.Louis, MO 63103 Contact: Les Nolan Telephone: 314-992-8903	No
Verizon 500 Technology Dr Weldon Spring, MO 63304 Contact: Ryan Tasker Telephone: 314-565-6946	No
City of Clayton (Lighting, Traffic, Signals, and Irrigation) 10 N Bemiston Ave. Clayton, MO 63105 Contact: Mike Leady Telephone: 314-290-8550	No
St. Louis County (Traffic and Signals) Telephone: 314-615-0215	No

1.1 The existence and approximate location of utility facilities known to exist, as shown on the plans, are based upon the best information available to the City at this time. This information is provided by the City "as-is" and the City expressly disclaims any representation or warranty as to the completeness, accuracy, or suitability of the information for any use. Reliance upon this information is done at the risk and peril of the user, and the City shall not be liable for any damages that may arise from any error in the information. It is, therefore, the responsibility of the contractor to verify the above listing information indicating existence, location and status of any facility. Such verification includes direct contact with the listed utilities.

1.2 The contractor agrees that any effects of the presence of the utilities, their relocation, contractor's coordination of work with the utilities and any delay in utility relocation shall not be compensable as a suspension of work, extra work, a change in the work, as a differing site condition or otherwise including but, without limitation, delay, impact, incidental or consequential

damages. The contractor's sole remedy for the effects of the presence of utilities, delay in their relocation or any other effects shall be an excusable delay as provided in Section 105.7.3. The contractor waives, for itself, its subcontractors and suppliers the compensability of the presence of utilities, delay in their relocation and any cost to the contractor, its subcontractors and suppliers in any claim or action arising out of or in relation to the work under the contract.

1.3 The contractor shall be solely responsible and liable for incidental and consequential damage to any utility facilities or interruption of the service caused by it or its subcontractors operation. The contractor shall hold and save harmless the City from damages to any utility facilities interruption of service by it or its subcontractor's operation.

2.0 It shall be noted by the contractor that MoDOT is a member of Missouri One Call (800 Dig Rite). Some work on this project may be in the vicinity of MoDOT utility facilities, which includes but is not limited to traffic signal cables, highway lighting circuits, ITS cables, cathodic protection cables, etc. Prior to beginning work, the contractor shall request locates from Missouri One Call. The contractor shall also complete the Notice of Intent to Perform Work form located at the Missouri Department of Transportation website:

<http://www.modot.mo.gov/asp/intentToWork.shtml>

The contractor shall submit the form over the web (preferred method) or by fax to the numbers on the printed form. The notice must be submitted a minimum of 2 and a maximum of 10 working days prior to excavation just as Missouri One Call requires.

Potential required utility adjustments:

Spire Energy: No conflict is anticipated

AT&T: No conflict is anticipated

Missouri American Water Company (MAWC): No conflict is anticipated

Charter: No conflict is anticipated

Ameren: No conflict is anticipated

Verizon: No conflict is anticipated

City of Clayton: No conflict is anticipated

St. Louis County: No conflict is anticipated. Coordination with County with installation of new detector loops and pavement striping at the MeramacAve/Shaw Park Dr and Bonhomme Ave/Hanley Rd intersections will be necessary.

4.0 Basis of Payment. No direct payment will be made for Utility Coordination. Utility Coordination should be considered part of, and incidental to the pay item “Mobilization”. No payment will be made to the Contractor for Remobilization if the Contractor pulls off of the site.

G. REMOVAL OF IMPROVEMENTS

1.0 Description. This work shall consist of the removal and disposal of all existing improvements, except those designated or permitted to be left in place or to be removed under other items of work, from the right-of-way and within the limits of any construction area outside the right-of-way. Improvements, to be left in place within construction limits, must be adequately protected and remain in operating condition.

Removal of improvements shall include removing all buildings, drainage structures, all rigid, reinforced, flexible or combination pavements, curb, curb and gutter, sidewalk, curb ramps, medians, pavement and sidewalk subbase, signs, utility chambers other objects or structures including scattered or piled bricks, stones, broken masonry, rubbish, debris, etc. from building demolition work, signal related items, and other existing improvements. This item shall also include full depth saw cuts, the salvaging of materials as designated in the contract, and the backfilling of the resulting trenches, holes and pits, and any grading work required to shape, smooth, and finish the disturbed areas.

The plans may not show a complete list of all items to be removed. There may be an undetermined number of abandoned utilities, basement or foundation walls, columns, footings, other types of building appurtenances, or other improvements encountered. The Contractor shall determine for himself the extent of the work to be performed under this item and shall base his bid accordingly. When portions of existing buildings are to be removed and portions are to remain, the Contractor shall exercise extreme care to protect the portions of the buildings that are to remain. The Contractor shall confine his activities within the construction limits and the easement lines shown on the plans.

2.0 Materials. All concrete material must be taken to an approved concrete-recycling facility, and documentation of delivery (load tickets) must be provided.

3.0 Equipment. All equipment and tools necessary for handling material and performing all parts of work shall be satisfactory to the City Engineer as to design, capacity and mechanical condition, and in accordance with Section 202 of the Standard Specifications

4.0 Execution. This work includes all locations where removals of sidewalks, curb ramps, curbs, roadway, medians, signs, and other materials will occur, as directed by the City Engineer.

The improvements to be removed shall be freed from adjacent structures to remain by saw cutting through the complete depth of the structure. The improvements inside the full depth saw cut shall be broken by methods suitable to the Contractor and approved by the City Engineer. The Contractor's removal operation shall not cause damage to the existing improvement that is to be used in place, underground utilities, drainage structures, irrigation facilities or other buried improvements under the improvements. Any damage including damage to improvements that are to be used in place shall be repaired by the Contractor at no expense to the City.

Sufficient pavement removal shall be made to provide for a smooth riding surface, proper grades to provide positive drainage to stormwater inlets and secure connections to existing pavement to be used in place.

The Contractor shall be required to perform all work in phases to maintain traffic. The City will coordinate this phasing with the Contractor prior to starting the work. No additional payment or extension of time will be made to the Contractor for any phased construction.

All items removed shall be properly disposed of off the project site by the Contractor in accordance with all state and local laws, unless otherwise approved by the City Engineer. **All concrete material must be taken to an approved concrete-recycling facility, and documentation of delivery (load tickets) must be provided.**

5.0 Method of Measurement. The work provided herein will not be measured for payment. This shall include the removal of all items, whether in view or hidden underneath the surface of the ground, regardless of whether shown on the plans or encountered during construction.

6.0 Basis of Payment. Payment for the Removal of Improvements shall include all necessary labor, materials, equipment and operations necessary to carry out the work and will be paid for at the contract unit price per lump sum.

H. CONCRETE BASE (8", NON-REINFORCED)

1.0 Description. This work shall consist of the removal and replacement of the existing concrete base on an as-needed basis, following the removal of the asphalt overlay, and as pavement repair for drainage trenches. Areas to be removed and replaced will be determined by the City Engineer.

Related Documents: Drawings and general provisions of Contract, including General and Supplementary Conditions and Job Special Provisions, apply to this section.

2022 St. Louis County Standard Specifications for Road and Bridge Construction shall be considered the Standard Specification. Except as noted in these specifications, all specified material, labor and equipment under this section shall comply with the latest edition of the St. Louis County Standard Specifications for Highway Construction including but not limited to section 309, and division 1000.

There will be no additional compensation based upon existing thickness. The new cross-section in all cases will include 8” of PCC on 4” of compacted aggregate base course.

Submittals: Provide samples, copies of manufacturer's product data, test reports, and materials certifications (signed by material producer and Contractor) certifying that each material item complies with, or exceeds, specified requirements as required by the City Engineer.

2.0 Materials.

Mix Design: The mix design is subject to review and approval by the City Engineer no later than 14 days prior to first use. Any change in the mix design shall require approval by the City Engineer.

Aggregate: All Portland Cement Concrete (PCC) shall contain Meramec sand and gravel (maximum size 1”) unless otherwise specified by the City Engineer. **PCC WITH LIMESTONE AGGREGATE SHALL NOT BE ACCEPTED. ALL PCC POURED WITH LIMESTONE AGGREGATE SHALL BE REMOVED AND REPLACED WITH THE APPROVED MIX WITHOUT ANY COMPENSATION FOR THE PCC WITH LIMESTONE AGGREGATE, ITS REMOVAL AND DISPOSAL.**

Cement: All concrete shall be Class A with Type 1 cement.

All PCC pavements shall contain 8 ½ sacks of cement.

Water: The maximum water per sack shall be 5 ¼ gallons. **No water shall be added to the concrete mix once it leaves the batch plant without the City's approval.**

Slump: All PCC shall have a maximum slump of 3 inches based on AASHTO T 119. A tolerance of ±½ inch may be permitted.

Air-Entrained: Air-entrained concrete shall be used for all construction with a 5 ½ % air content (by volume) specified. A tolerance of ±1 ½ % (by volume) may be permitted. The City Engineer may request and shall receive adjustments to the air content, in order to affect the serviceability of the concrete. Air content will be determined by the pressure method as specified in AASHTO T 152.

Admixtures: The use of admixtures not herein specified is prohibited unless the City Engineer grants prior approval.

Strength: All PCC pavements shall have minimum compression strength of 3,500 psi at three (3) days and a minimum compressive strength of 4,500 psi at twenty-eight (28) days. Compressive strength will be determined from samples prepared and tested by the City Engineer in accordance with ASTM C31-86 and ASTM C39-86.

Crushed Aggregate Base Course: Conform to St. Louis County Standard Specification for Highway Construction Section 304 AGGREGATE BASE COURSE.

Curing Compound: Type 2, liquid membrane-forming curing compounds shall be in accordance with AASHTO M 148 for Type 2, white pigmented. Type 2 curing compounds are applied to Portland cement concrete pavements.

Equipment.

General: All equipment and tools necessary for handling material and performing all parts of work shall be satisfactory to the City Engineer as to design, capacity and mechanical condition, and in accordance with Section 309 of the Standard Specifications

Forms: Forms shall be placed on a prepared subgrade of uniform density. Forms shall be metal or sound dressed lumber, straight, free from warp, of sufficient strength to resist springing during construction and of a height equal to the full depth of the item to be constructed. Wood forms shall have a minimum nominal thickness of two inches (2") except where flexible forms are used. Flexible forms shall be thoroughly cleaned, well oiled, securely staked, braced and held to the required line and grade. Form work shall be incidental to the placement of concrete base.

3.0 Execution.

Removal of Existing Pavement: This work includes locations where removals of a partial slab, full slab, multiple slabs or any combination there of will occur, as directed by the City Engineer.

The concrete pavement to be removed shall be freed from the pavement to remain by saw cutting through the complete depth of the pavement. The pavement inside the full depth saw cut shall be broken by methods suitable to the Contractor and approved by the City Engineer. The Contractor's removal operation shall not cause damage to the existing pavement that is to be used in place, underground utilities, drainage structures, irrigation facilities or other buried improvements under the pavement. Any damage including damage to pavement that is to be used in place shall be repaired by the Contractor at no expense to the City.

Sufficient pavement removal shall be made to provide for a smooth riding surface, proper grade to provide positive drainage to storm water inlets, and secure connections to existing pavement to be used in place.

The Contractor shall be required to perform all work including the removal and replacement of the concrete pavement in phases to maintain traffic. The City will coordinate this phasing with the Contractor prior to starting the work. No additional payment or extension of time will be made to the Contractor for any phased construction.

All items removed shall be properly disposed of off the project site by the Contractor in accordance with all state and local laws, unless otherwise approved by the City Engineer. **All concrete material must be taken to an approved concrete-recycling facility, and documentation of delivery (load tickets) must be provided.**

Saw cutting and the removal of existing pavement shall be included in Removal of Improvements.

Subgrade Preparation: The Aggregate Base shall be placed on a uniform stable subgrade. In no case shall Aggregate Base be placed on a muddy subgrade. If soft spots or unsuitable material is encountered at the subgrade elevation notify the City Engineer immediately.

Soft or wet areas resulting from weather or the sequence of Contractor operations do not constitute undergrading and shall be removed and replaced as determined by the Owner at the Contractor's expense. Stumps, trees, rubbish, unstable soil, frozen lumps or any deleterious materials or substance shall not be placed or allow to remain in the subgrade.

Immediately prior to surfacing, the subgrade shall be shaped to the grade and cross section indicated on the drawings. The top 6 inches of the subgrade shall be compacted to 95% maximum density as determined by the Standard Proctor Test AASHTO T-99 (ASTM D-698). The material shall be placed at $\pm 2\%$ of the optimum moisture content. This operation shall include any scarifying, reshaping and wetting required to obtain the specified compaction.

Any deviation of the surged surface in excess of 1 inch, as indicated by a 16 foot straightedge or template cut to typical section, shall be corrected by loosening, adding or removing material, reshaping and re-compacting.

No separate payment shall be made for work provided herein. This work shall be considered incidental to the item Concrete Base (8", Non-Reinforced).

Aggregate Base: This work shall consist of furnishing, placing and compacting a four inch (4") aggregate base course under the concrete pavement in conformity with the typical sections of details shown in the plans and in accordance with the provisions of Section 304 of the St. Louis County Standard Specifications.

Aggregate shall be placed on the subgrade in a layer of uniform thickness not exceeding 4 inches in compacted depth. The aggregate for each course shall be handled and spread in a manner that will prevent segregation of sizes. At the discretion of the City Engineer, a greater layer thickness may be considered if it can be clearly demonstrated that the desired compaction can be obtained for the entire layer thickness.

Each layer shall be cleaned of loose and foreign matter before the subsequent layer is placed. Water content of the material shall be maintained during placement. Moisture content shall be maintained at +2 percent of optimum.

The aggregate shall be compacted to not less than 100 percent of the maximum laboratory density as determined by the Standard Proctor Test AASHTO T-99 (ASTM D-698).

Top surface of the compacted aggregate base course shall be finished by blading or with automated equipment specially designed for the purpose and compacted with the proper equipment to achieve density requirements. Addition of thin layers of fine materials to the top of the base course to meet the grade will not be acceptable.

Surfaces of the completed aggregate base shall not deviate more than $\frac{1}{2}$ inch when tested with a 10 foot straightedge. The completed compacted thickness of any course shall be within plus $\frac{3}{4}$ inch and minus $\frac{1}{2}$ inch of indicated thickness, and the average thickness shall not be less than the design thickness indicated.

No separate payment shall be made for work provided herein. This work shall be considered incidental to the item Concrete Base (8", Non-Reinforced).

Concrete Base Replacement: This section shall consist of constructing non-reinforced PCC roadway base pavement in accordance with Section 309 of the St. Louis County Standard Specifications. All PCC roadway pavement shall be constructed of eight inches (8") of PCC.

Concrete shall be placed on the prepared aggregate base in a manner to avoid segregation and contamination. Concrete vibrators of an internal type shall be used in compacting and consolidating all concrete. The units shall be capable of providing a minimum of 4,500 impulses per minute.

A 10-foot straight edge will be used for all pavement replacement areas, and irregularities exceeding one-fourth inch ($\frac{1}{4}$ ") within the ten feet (10') will be cause for rejection. Concrete shall be bull-floated after consolidation and stuck off to produce the desired cross slope and thickness shown in the construction details.

The finished concrete surface shall be wire-comb or broom finish with a medium-fiber street broom as directed by the City Engineer in a transverse direction to produce a skid-resistant finish. The strokes will be square across the slab, from edge to edge, with adjacent strokes slightly overlapped, and shall be made by drawing the broom without tearing the concrete, but to produce regular corrugates not over one-eighth inch ($\frac{1}{8}$ ") in depth.

All joints conform to Drawing C502.03, JOINTS AND CURBS, St Louis County Department of Highways and Traffic. At locations where adjacent longitudinal concrete pavement is designated for replacement, a "Type G" longitudinal control joint shall be installed. Transverse control joints in pavement shall conform to "TYPE G" transverse construction joints.

All dowels shall be centered exactly over the joint.

The Contractor will drill and install dowels to connect new pavement to existing concrete pavement that will remain. The Contractor shall exercise care to protect the dowels until new concrete pavement is placed.

All joints shall be sawed. **Pre-molded strips shall not be used in place of saw cutting joints.**

Control joints in the pavement shall match existing joint layout.

All joint layouts shall be approved 24 hours prior to pouring concrete. All unapproved joints shall be removed and replaced at no expense to the City.

All joints shall be cut as close as is practical to the pavement edge. Sawing of joints shall commence as soon as the concrete has hardened sufficiently to permit sawing without raveling. All joints shall be sawed before shrinkage cracking takes place. In general, all joints shall be sawed in sequence.

All structures (i.e. manholes, grated inlets, etc) shall be separated from the pavement by three-eighths or one-half inch ($\frac{3}{8}$ " or $\frac{1}{2}$ ") closed-cell poly foam expansion joint material approved by the City Engineer. Expansion material shall be the full depth of the concrete pavement.

All joints shall be placed at right angles to or radial to the centerline of the pavement unless directed otherwise by the City Engineer.

Immediately after finishing operations have been completed and as soon as marring of the concrete will not occur, the entire surface of the newly-placed concrete shall be covered and cured in accordance with the following method.

Within thirty (30) minutes after the free water has left the pavement surface, the entire surface shall be sealed by hand or machine spraying with a uniform application of white pigmented membrane curing material.

The Contractor shall provide satisfactory equipment to insure uniform coverage of curing material, without loss, on the pavement at the rate of one (1) gallon for each 150 square feet or as specified by the manufacturer.

If rain falls on the newly coated pavement before the film has dried sufficiently to resist damage, or if the film is damaged in any other way, the Contractor will be required to apply additional curing material to the affected surface.

A deduction of thirty percent (30%) of the bid price for a full slab shall be made for concrete pavement not cured in strict accordance with the above method.

No separate payment shall be made for work provided herein. This work shall be considered incidental to the item Concrete Base (8", Non-Reinforced).

4.0 Measurement. Concrete Base (8", Non-Reinforced): The quantity shall be measured as the number of square yards of pavement replaced by the Contractor and accepted by the City Engineer.

5.0 Payment. Payment shall be at the unit bid price per square yards and shall be full compensation for furnishing all required labor and materials to complete the Work per these specifications.

I. ADJUST UTILITY SERVICE OR FACILITY TO GRADE

1.0 Section 603 of the St. Louis County Standard Specification for Road and Bridges shall be amended as follows:

2.0 Description. This work shall include adjustment of any and all utilities within the project area, such as gas access boxes, telephone facilities, cable boxes, water valve boxes, etc., as necessary to match the finished lines and grades established with this project. Minor adjustments accomplished with the existing facilities not requiring additional materials, grade rings, etc. will be considered incidental to the construction.

3.0 Method of Measurement. Adjustments of utilities falling under this specification shall be made as necessary with the approval of the Engineer and will be measured as each. Minor adjustments accomplished with the existing facilities not requiring additional materials, grade rings, etc. will be considered incidental to the construction.

4.0 Basis of Payment. Payment for the adjustment of utilities falling under this specification shall include all necessary labor, materials, equipment and operations necessary to carry out the work and will be paid for at the contract unit price per each.

J. EQUIPMENT AND/OR MATERIAL STORAGE AREA

1.0 The City has not provided a material and/or equipment storage area (bone yard) for this project. Any such area required by the Contractor is to be acquired by the Contractor.

2.0 If the storage area is located along the project or within the City limits the Contractor must provide proof of permission to use the site. At the end of the project, prior to project closeout, the Contractor must provide to the City a release from the property owner. The release is to indicate the property owner is satisfied with the condition the Contractor left the property.

K. REMOVAL AND SALVAGE OF CITY SIGNS

1.0 Description. All existing signs and sign posts not used during the construction of the roadway improvements, i.e. stops signs and street ID signs, shall remain the property of the City and shall be carefully removed and stockpiled in a location designated by the Director of Public Works for salvage by the City.

L. AGGREGATE BASE COURSE

1.0 Description. This work shall consist of the placement and compaction of Type 1 Aggregate Base (4" Thick) under all new concrete base, concrete curb ramps, concrete sidewalks, concrete curb and gutters, PCC base for concrete pavers, and brick paver strips base as shown in the plans and in accordance with the provisions of Section 304 of the St. Louis County Standard Specifications. Aggregate base course under areas where concrete curb and gutter is shown, a width equal to the trench width (3.5 feet) shall be installed.

Related Documents: Drawings and general provisions of Contract, including General and Supplementary Conditions and Job Special Provisions, apply to this section.

2022 St. Louis County Standard Specifications for Road and Bridge Construction shall be considered the Standard Specification. Except as noted in these specifications, all specified material, labor and equipment under this section shall comply with the latest edition of the St. Louis County Standard Specifications for Road and Bridge Construction including but not limited to section 304, and division 1000.

Submittals: Provide samples, copies of manufacturer's product data, test reports, and materials' certifications signed by material producer and Contractor, certifying that each

material item complies with, or exceeds, specified requirements as required by the City Engineer.

2.0 Materials

Aggregate: Aggregate shall consist of crushed stone as defined in Section 1007 of the St. Louis County Standard Specifications for Highway Construction.

Equipment

General: All equipment and tools necessary for handling material and performing all parts of work shall be satisfactory to the City Engineer as to design, capacity and mechanical condition.

3.0 Execution

Placement: Aggregate shall be placed on the subgrade in a layer of uniform thickness not exceeding 4 inches in compacted depth. The aggregate for each course shall be handled and spread in a manner that will prevent segregation of sizes. A greater layer thickness may be considered if it can be clearly demonstrated that the desired compaction can be obtained for the entire layer thickness. Each layer shall be cleaned of loose and foreign matter before the subsequent layer is placed. Water content of the material shall be maintained during placement. Moisture content shall be maintained at + 2 percent of optimum.

Compaction: The aggregate shall be compacted to not less than 100 percent of the maximum laboratory density as determined by the Standard Proctor Test AASHTO T-99 (ASTM D-698).

No separate payment shall be made for work provided herein. This work shall be considered incidental to the other pay items.

Grading: The top surface of the compacted aggregate base course shall be finished by grading with automated equipment specially designed for the purpose and rolled with a steel-wheeled roller. Addition of thin layers of fine materials to the top of the base course to meet the grade will not be acceptable.

Surfaces of the completed aggregate base shall not deviate more than ½ inch when tested with a 10 foot straightedge. The completed compacted thickness of any course shall be within plus ¾ inch and minus ½ inch of indicated thickness, and the average thickness shall not be less than the design thickness indicated.

This work shall include any earthwork (excavation and/or borrow) for the aggregate base construction.

No separate payment shall be made for work provided herein. This work shall be considered incidental to the other pay items.

4.0 Measurement. Type 1 Aggregate Base (4" Thick): The work provided herein will not be directly measured for payment and this work shall be considered incidental to other pay items. The quantity

shall be included with the corresponding items detailed in other sections which include aggregate base.

5.0 Payment. No separate payment shall be made for this work. This work shall be considered incidental and shall include furnishing all required labor and materials to complete the Work per these specifications.

M. SUPERPAVE ASPHALT

1.0 Description. This work shall consist of providing a Superpave asphaltic concrete mixture in conformance with the lines, grades, thicknesses, and typical cross sections shown on the plans, in accordance with Section 404 of the St. Louis County Standard Specifications.

1.1 The following edits shall be made to said paving specification:

ADD: Joints: All transverse joints, butt joints, or edges of pavement that have cooled below the allowable rolling temperature shall be formed by saw cutting to produce a dense, vertical section.

The joint formed when the fresh mixture is placed shall be dense, well-sealed, and the grade, line, and surface texture of the succeeding surface shall conform to that of the joined surface.

2.0 No measurement or payment will be made for this requirement. The cost to perform paving in this manner shall be incidental to the bid items to which it pertains.

N. HIGH TENSILE STRENGTH SYNTHETIC FIBERS FOR ASPHALT

1.0 Description. This work shall consist of adding a high tensile strength synthetic fiber to the bituminous mixture to be placed as specified in the contract documents. The Fiber Reinforced Asphalt Concrete (FRAC) mixture produced shall meet all Section 404 of the St. Louis County Standard Specifications. The material properties, handling, mixing and placement of the fibers shall be in accordance with this provision.

2.0 Materials.

Fiber Properties. The reinforcing fibers shall contain aramid fibers and a dispersion aid that meet the following material requirements as detailed in Table 1 below:

Table 1 – Aramid Reinforcing Fibers Material Properties		
Property	Test Method	Criteria
Form	Manufacturer Certification	Aramid Fibers

Length (in)	Manufacturer Certification	0.75
Melting Temperature	Manufacturer Certification	800 F
Nominal Specific Gravity (g/cm ³)	ASTM D276	1.44
Tensile Strength ¹ (psi)	ASTM D7269	400,000

Performance Testing. A FRAC mixture shall meet the following performance test detailed in Table 2 below. Non-aramid fiber blends will not be considered alternatives to this specification. All performance testing results from previous laboratory trial FRAC mixtures shall be submitted to the Engineer along with the job mix formula.

Table 2 – FRAC Mixture Performance Requirements			
Performance Measure	Test Method	Standard	Requirement
Dispersion Efficiency, %	Aramid Dispersion State Ratio (ADSR)	Modified ASTM D2172	≥ 85 %
Cracking Resistance, % increase	Indirect Tensile Strength (IDT)	AASHTO T 322 or ASTM D6931	≥ 20 % increase
Resistance to Permanent Deformation (Rutting)	Flow Number	AASHTO TP 79	≥ 35 % increase
	Hamburg	AASHTO T 324	< 3 mm

Performance testing shall be from previous completed laboratory trials performed on plant mixed FRAC. Testing is not required on samples from the job mix. Performance testing shall be from laboratory trials at a fiber dosage rate equal to the rate proposed for the project. Tests must be performed by an AASHTO accredited testing lab and must be reviewed and approved by the Engineer.

Aramid Dispersion State Ratio (ADSR) tests shall be conducted from a minimum of three separate laboratory FRAC trials in accordance with the following:

1. Perform ADSR test in accordance with Modified ASTM D2172 (test method documentation available in the Electronic Deliverables).
2. The average extracted aramid fiber quantity shall equal 0.007 percent by total sample weight with no individual result less than 0.005 percent of the total sample weight.
3. All tested fiber mixes shall achieve a minimum ADSR of 85%.

Indirect Tensile (IDT) Strength Tests shall be conducted from a minimum of three (3) separate laboratory trials in accordance with the following:

1. Perform indirect tensile tests using the protocol from AASHTO T322 or ASTM D6931.
2. Tests results shall include a control and a fiber reinforced mix. FRAC mix shall be identical to control mix except for the inclusion of fibers added at the same dosage as proposed on the project.

3. Indirect tensile test results from fiber specimens shall show an average tensile strength increase of 30 percent over control specimen with no samples having less than 25 percent increase of average tensile strength.

Resistance to Permanent Deformation (Rutting) shall be measured on the FRAC mixture by one of the following test methods: Flow Number Test or Hamburg.

Flow Number (FN) testing shall be performed on a minimum of three (3) separate laboratory trials in accordance with the following:

1. Perform flow number testing in accordance with AASHTO TP79.
2. Test results shall include a control mixture and a FRAC mixture. The FRAC mixture shall be identical to the control mix except for the inclusion of fibers added at the same dosage rate as proposed on the project.
3. Results from the FRAC specimens shall each show an average FN increase of at least 35 percent over the control specimens.

Hamburg testing shall be performed on a minimum of three (3) separate laboratory trials in accordance with the following:

1. Perform Hamburg testing in accordance with AASHTO T324.
2. Test results may include only the FRAC mixture at the same dosage rate as proposed on the project.
3. Results from the FRAC specimens shall show less than 3 mm of rutting.

Required Information. The Contractor shall furnish a manufacturer's certification to the Engineer for each lot of material furnished stating the name of the manufacturer, the chemical composition, and certifying that the material supplied is in accordance with this specification.

3.0 Execution.

Delivery, Storage, and Handling. The fiber-reinforcement material shall be delivered, stored, and handled in accordance with the manufacturer's recommendations and specifically as follows:

1. Deliver fiber-reinforcement in sealed, undamaged containers with labels intact and legible, indicating material name and lot number.
2. Deliver fiber-reinforcement to location where it shall be added to each batch or loaded into the mixer.
3. Store materials covered and off the ground. Keep sand and dust out of boxes and do not allow boxes to become wet.

Mixing and Production. The system for adding fibers to the mix shall be approved by the fiber manufacturer. The Engineer shall be informed in writing that the system being used to add the fibers in the asphalt mixture meets the fiber manufacturer's recommendations.

The fiber reinforcement shall be added at the dosage rate that meets the FRAC Mixture Performance Requirements listed in Table 2 as prescribed by the manufacturer. A fiber manufacturer shall be on site during the mixing and production of FRAC material.

The following construction steps shall be used when producing the FRAC or as required by the manufacturer.

Batch Plant: When a batch plant is used, add fiber to the aggregate in the weigh hopper and increase both dry and wet mixing times. Ensure that the fiber is uniformly distributed before the injection of asphalt cement into the mixture.

Drum Plant: For drum plants, inject fibers through the reclaimed asphalt pavement (RAP) collar using an automatic, metered air blown system to promote rapid and complete fiber dispersion. System must automatically record fiber addition data so as to remove human error. Rate the feeding of fibers with the rate the plant is producing asphalt mix. If there is any evidence of fiber bundles at the discharge chute, increase the mixing time and/or temperature or change the angle of the fiber feeder line to increase dry mixing time.

For small quantity projects less than 2000 tons, manual feeding of the fibers may be allowed in accordance with the manufacturers recommendations. For projects greater than 2000 tons, manual feeding of the fibers is not allowed.

For blower tube system, add fibers continuously and in a steady uniform manner. Provide automated proportioning devices and control delivery within $\pm 10\%$ of the mass of the fibers required. Perform an equipment calibration to the satisfaction of the fiber manufacturer's representative to show that the fiber is being accurately metered and uniformly distributed into the mix.

Include the following for blower tube system:

1. Low level indicators
2. No-flow indicators
3. A printout of feed rate status in pounds/ minute
4. A section of transparent pipe in the fiber supply line for observing consistency of flow or feed.

Quality Control. A minimum of 25 pounds FRAC sample shall be collected during the first 50 tons of production. The sample shall be visually inspected to determine the uniform dispersion of the aramid fibers in an individual state (no bundles or agitated bundles). If undistributed bundles exist, the plant shall adjust the mixing operations until the aramid fibers are in an individual state.

Placement. In addition to the visual inspection the FRAC mix shall be visually observed in the back of first three trucks and every tenth truck thereafter to confirm the adequate blending of the fibers.

4.0 Measurement.

The quantity of high tensile strength synthetic fiber shall be measured as the number of pounds of fibers added to the approved asphaltic pavement design and accepted by the City Engineer.

5.0 Payment.

Payment for the high tensile strength synthetic fibers for asphalt shall be full compensation for furnishing all required labor and materials to complete the Work per these specifications and will be

paid for at the contract unit price bid per pound for High Tensile Strength Synthetic Fibers For Asphalt.

O. ECHELON PAVING REQUIREMENT

1.0 The Standard Specifications shall be amended to require the use of Echelon paving, as follows:

1.1 Paving in Echelon means two or more pavers are used to pave multiple adjacent lanes simultaneously so that no longitudinal cold joints are left in the pavement.

1.2 Pavers working in echelon shall maintain a distance of less than 200-feet between them.

1.3 The longitudinal alignment of the spreader shall be controlled by the use of a string line placed at each outer edge of the pavement , or other control method approved by the City.. The spreader shall be directed at all times by this method and not by the edge of the preceding course, except for the trailing paver when paving in echelon.

1.4 Pavement allowed to cool below permitted rolling temperature shall be cut to produced a vertical edge, acceptable to the City Engineer, before an adjacent lift of asphalt is placed.

2.0 No measurement or payment will be made for this requirement. The cost to perform paving in this manner shall be incidental to the bid items to which it pertains.

P. USE OF MERAMEC SAND AND GRAVEL IN CONCRETE

1.0 The use of Meramec sand and Meramec gravel shall be used in all concrete mix designs for the project.

2.0 No measurement or payment will be made for this requirement. The cost to include this type of sand or gravel or comply with these mix designs shall be incidental to the bid items to which they pertain.

Q. VARIABLE HEIGHT TRENCH DRAIN SYSTEM

1.0 Description This work shall consist of the installation of the variable height trench drain system in accordance with manufacturer's recommended installation instructions and details, and in conformity with the lines, grades, thicknesses and details shown on the plans or established by the City Engineer.

Related Documents: Drawings and general provisions of Contract, including General and Supplementary Conditions and Job Special Provisions, apply to this section.

Submittals: Provide samples, copies of manufacturer's product data, test reports, and materials' certifications signed by material producer and Contractor, certifying that each material item complies with, or exceeds, specified requirements as required by the City Engineer.

Delivery, Storage, and Handling

Refer to manufacturer's ordering instructions and lead time requirements to avoid construction delays.

Delivery: Deliver materials in manufacturer's original, unopened, undamaged containers packaging with identification labels intact. Coordinate delivery and paving schedule to minimize interference with normal use of buildings adjacent to paving.

2.0 Materials.

Pipe:

American Association of State Highway and Transportation Officials (AASHTO):

AASHTO M 252: Standard Specification for Corrugated Polyethylene Drainage Pipe

AASHTO M 294: Standard Specification for Corrugated Polyethylene Pipe, 300- to 1500-mm (12- to 60-in.) Diameter

AASHTO F 2306: Standard Specification for 12 to 60 in. [300 to 1500 mm] Annular Corrugated Profile-Wall Polyethylene (PE) Pipe and Fittings for Gravity-Flow Storm Sewer and Subsurface Drainage Applications

Concrete:

Mix Design: The mix design is subject to review and approval by the City Engineer no later than 14 days prior to first use. Any change in the mix design shall require approval by the City Engineer.

Aggregate: All Portland Cement Concrete (PCC) shall contain Meramec sand and gravel (maximum size 1") unless otherwise specified by the City Engineer. **PCC WITH LIMESTONE AGGREGATE SHALL NOT BE ACCEPTED. ALL PCC POURED WITH LIMESTONE AGGREGATE SHALL BE REMOVED AND REPLACED WITH THE APPROVED MIX WITHOUT ANY COMPENSATION FOR THE PCC WITH LIMESTONE AGGREGATE, ITS REMOVAL AND DISPOSAL.**

Cement: All concrete shall be Class A with Type 1 cement.

All PCC pavements shall contain 8 ½ sacks of cement.

Water: The maximum water per sack shall be 5 ¼ gallons. **No water shall be added to the concrete mix once it leaves the batch plant without the City's approval.**

Slump: All PCC shall have a maximum slump of 3 inches based on AASHTO T 119. A tolerance of $\pm\frac{1}{2}$ inch may be permitted.

Air-Entrained: Air-entrained concrete shall be used for all construction with a 5 $\frac{1}{2}$ % air content (by volume) specified. A tolerance of $\pm 1 \frac{1}{2}$ % (by volume) may be permitted. The City Engineer may request and shall receive adjustments to the air content, in order to affect the serviceability of the concrete. Air content will be determined by the pressure method as specified in AASHTO T 152.

Admixtures: The use of admixtures not herein specified is prohibited unless the City Engineer grants prior approval.

Strength: All PCC pavements shall have minimum compression strength of 3,500 psi at three (3) days and a minimum compressive strength of 4,500 psi at twenty-eight (28) days. Compressive strength will be determined from samples prepared and tested by the City Engineer in accordance with ASTM C31-86 and ASTM C39-86.

Curing Compound: Type 2, liquid membrane-forming curing compounds shall be in accordance with AASHTO M 148 for Type 2, white pigmented. Type 2 curing compounds are applied to Portland cement concrete pavements.

Aggregate Base Course: Conform to St. Louis County Standard Specification for Highway Construction Section 304 AGGREGATE BASE COURSE.

3.0 Execution.

The variable height trench drain system shall be installed in accordance with the manufacturer's recommendations and as detailed in the plans, or as directed by the City Engineer.

4.0 Measurement.

The quantity of variable height trench drain system shall be measured per linear feet installed, per the manufacturers' recommendations and as detailed in the plans, and accepted by the City Engineer.

5.0 Payment.

Payment for the variable height trench drain system shall be full compensation for furnishing all required labor and materials to complete the Work per these specifications and will be paid for at the contract unit price bid per linear feet. Payment under the unit cost bid per each shall be full compensation for this work, and no additional payment will be made for sawcuts, pavement removals, concrete, expansion joints, connections, or any other items required for the installation of the variable height trench drain system.

R. CONCRETE CURB AND GUTTER, TYPE A (8 IN.)

1.0 Description. This work shall consist of the construction of Portland Cement Concrete Curb and Gutter on 4" of compacted aggregate base course, on a prepared subgrade in accordance with these specifications and in conformity with the lines, grades, thicknesses and typical cross sections shown on the plans or established by the City Engineer.

Related Documents: Drawings and general provisions of Contract, including General and Supplementary Conditions and Job Special Provisions, apply to this section.

2022 St. Louis County Standard Specifications for Road and Bridge Construction shall be considered the Standard Specification. Except as noted in these specifications, all specified material, labor and equipment under this section shall comply with the latest edition of the St. Louis County Standard Specifications for Road and Bridge Construction including but not limited to section 609, and division 1000.

Sheet C9.1 of the Plans includes a typical detail (SD-7) of this work as it is to be performed.

Submittals: Provide samples, copies of manufacturer's product data, test reports, and materials' certifications signed by material producer and Contractor, certifying that each material item complies with, or exceeds, specified requirements as required by the City Engineer. Curb and joint mortar should match existing material and color.

2.0 Materials

Mix Design: The mix design is subject to review and approval by the City Engineer no later 14 days prior to first use. Any change in the mix design shall require approval by the City Engineer.

Aggregate: All Portland Cement Concrete (PCC) shall contain Meramec sand and gravel (maximum size 1") unless otherwise specified by the City Engineer. **PCC WITH LIMESTONE AGGREGATE SHALL NOT BE ACCEPTED. ALL PCC POURED WITH LIMESTONE AGGREGATE SHALL BE REMOVED AND REPLACED WITH THE APPROVED MIX WITHOUT ANY COMPENSATION FOR THE PCC WITH LIMESTONE AGGREGATE, ITS REMOVAL AND DISPOSAL.**

Cement: All concrete shall be Class A with Type 1 cement.

All PCC pavements shall contain 8 ½ sacks of cement.

Water: The maximum water per sack shall be 5 ¼ gallons.

Slump: All PCC shall have a maximum slump of 3 ½ inches based on AASHTO T 119. A tolerance of ±½ inch may be permitted.

Air-Entrained: Air-entrained concrete shall be used for all construction with a 5 ½ % air content (by volume) specified. A tolerance of ±1 ½ % (by volume) may be permitted. The City Engineer may request and shall receive adjustments to the air content, in order to affect

the serviceability of the concrete. Air content will be determined by the pressure method as specified in AASHTO T 152.

Admixtures: The use of admixtures not herein specified is prohibited unless the City Engineer grants prior approval.

Strength: All PCC pavements shall have a minimum compression strength of 3,500 psi at three (3) days and a minimum compressive strength of 4,500 psi at twenty-eight (28) days. Compressive strength will be determined from samples prepared and tested by the City Engineer in accordance with ASTM C31-86 and ASTM C39-86.

Color: Add pigment to match color of existing concrete as directed by the City Engineer.

Joint Filler: Expansion joint material shall be 1/2 inch thick pre-molded expansion joint filler. Furnish expansion joint fillers in one-piece lengths for the full width being placed.

Mortar: Mortar shall be colored to match that of the existing curb. Three samples must be submitted to the City Engineer for approval no less than 14 days prior to placement.

Aggregate Base: Aggregate base course for bedding shall conform with Section 1007 of the St. Louis County Standard Specifications. Aggregate base shall be Type 1. Concrete for embedment shall conform with the details shown on the plans.

Curing Compound: CS-309 non yellowing acrylic curing compound

Equipment

General: All equipment and tools necessary for handling material and performing all parts of work shall be satisfactory to the City Engineer as to design, capacity and mechanical condition.

Forms: Coat forms with a non-staining form release agent that will not discolor or deface surface of concrete. Forms shall be placed on a prepared subgrade of uniform density. Forms shall be metal or sound dressed lumber, straight, free from warp, of sufficient strength to resist distortion during construction and of a height equal to the full depth of the pavement to be constructed. Wood forms shall have a minimum nominal thickness of two inches except where flexible forms are used. No section shall show a variation greater than 1/8 inch in 10 feet from the true plane surface on the top and 1/4 inch in 10 feet along the face of the form. Flexible forms shall be securely staked, braced and held to the required line and grade. The method of connecting form sections shall ensure a tight, neat joint. All forms shall be clean and coated with a form release agent before concrete placement.

Vibrators: Vibrators used shall be of the internal type. They shall not come in contact with the reinforcement, load transfer devices, subgrade or side forms.

Concrete Saw: If sawed joints are required, equipment shall be provided complete with either an abrasive wheel or a diamond-edge water-cooled blade, capable of providing a groove of the specified dimensions in the hardened concrete. Contractor shall be responsible for dust control to prevent damage to surrounding property.

3.0 Execution

Removal of Existing Curb and Gutter: The Contractor shall remove and dispose of designated portions of the existing curb and gutter as shown on the plans or directed by the City Engineer. The existing curb and gutter shall be removed to the nearest expansion joint or separated from the portion to remain and the pavement by way of a full-depth sawcut. If sawcut, the cut shall be full-depth, straight, and smooth. The Contractor shall exercise care to protect the portions of the curb and gutter and pavement to remain. Damaged curb and gutter that is designated to be used in place shall be removed and replaced by the Contractor at no expense to the City. Care shall be taken to avoid breaking or otherwise damaging the existing granite curb. Any curb that is destroyed, damaged or otherwise rendered unfit for re-use shall be replaced at the expense of the Contractor.

Removal of Existing Curbs shall be included in Removal of Improvements.

Damage: The Contractor's removal operation shall not cause damage to utilities, drainage structures, buried pet containment fences or sprinkler systems. Any damage shall be repaired by the Contractor at no expense to the City.

Subgrade: Curb and gutter shall be constructed on compacted crushed aggregate base course in accordance with St. Louis County Standard Specification for Highway Construction Section 304 AGGREGATE BASE COURSE and the sections shown on the drawings.

Utility Adjustments: This work shall consist of locating and adjusting utility boxes and manholes as needed. This work shall be considered incidental.

Thickness: Concrete base shall be 8 inches thick as indicated in the detail.

Joints: Place 1/2-inch thick preformed asphalt-impregnated expansion joints at intervals not exceeding 15 feet, at the beginning and end of curved portions of the curb, and also at connections to existing curbs. Place contraction joints in the curb at intervals not exceeding 10 feet. Contraction joints shall be of the open joint type and shall be provided by inserting a thin, oiled steel sheet vertically in the fresh concrete to force coarse aggregate away from the joint. The steel sheet shall be inserted the full depth of the curb and gutter. After initial set has occurred in the concrete and prior to removing the front curb form, the steel sheet shall be removed with a sawing motion. Finish top of curb with a steel trowel and finish edges with a steel edging tool. Granite curb shall be spaced with joints to match existing curb. Joints shall be tuckpointed using a colored mortar to match that of the existing curb, as outlined in Section 609.2.1.9.

Form Construction: Set forms to required grades and lines, braced and secured. Install forms to allow continuous progress of work and so that forms can remain in place at least 24 hours after concrete placement. Clean forms after each use and coat with form release agent as required ensuring separation from concrete without damage.

Concrete Placement: Do not place concrete until sub-base and forms have been checked by the City Engineer for line and grade. Moisten sub-base, if required, to provide a uniform dampened condition at time concrete is placed. Place concrete by methods that prevent segregation of mix. Concrete shall be consolidated by vibrating the mixture promptly following placement. Consolidate concrete along face of forms and adjacent to transverse joints with internal vibrator.

Use only square-faced shovels for hand spreading and consolidation. As soon as the concrete has set sufficiently to support its own weight, remove the front curb form and finish all exposed surfaces. Finish formed face by rubbing with a burlap sack or similar device that will produce a uniformly textured surface, free of form marks, honeycomb, and other defects.

Cold Weather Placement: Mixing and concreting operations shall be discontinued when a descending ambient temperature away from artificial heat reaches 40 degrees Fahrenheit and not resumed until an ascending ambient temperature away from artificial heat reaches 35 degrees Fahrenheit. Concrete shall not be placed on subgrade with a temperature less than 35 degrees Fahrenheit. Concrete temperature shall not drop below 65 degrees Fahrenheit for a period of no less than 6 days after placement. Concrete exposed to melting snow during daytime and freezing during nighttime shall be protected from freezing until strength of at least 3500-psi has been attained and the City Engineer has received supporting documentation.

If approval has been granted for the Contractor to place the concrete while the ambient temperature is at or lower than 40 degrees Fahrenheit, the contractor shall take precautionary measures to prevent damage by freezing, such as heating mixing water, heating aggregates, or applying heat directly to the contents of the mixer. Aggregates shall not be heated higher than 150 degrees Fahrenheit, and the temperature of the aggregates and mixing water combined shall be not higher than 100 degrees Fahrenheit, when the cement is added. Unless otherwise authorized, the temperature of the mixed concrete when heating is employed shall not be less than 50 degrees Fahrenheit and not more than 80 degrees Fahrenheit at the time of placement. Cement or fine aggregate containing lumps or crusts of hardened material or frost shall not be used. Concrete shall not be placed upon a frozen subgrade.

Hot Weather: Hot weather is any time during the concrete placement that the ambient temperature at the work site is above 95° F (35° C). In hot weather, cool all surfaces that will come in contact with the mix to below 95° F (35° C). Cool by covering with wet burlap or cotton mats, fog spraying with water, covering with protective housing, or by other approved methods. Plastic concrete temperatures up to 100° F (38° C) as placed, may be permitted provided job site conditions allow placement and finishing without excessive use of water on and/or overworking of the surface. The occurrence within 24 hours of unusual surface distress shall be cause to revert to a maximum 90° F (32° C) plastic concrete temperature.

Water: Additional water shall not be added to the concrete mix once it leaves the batch plant without the approval of the City Engineer.

Hand-Mixing: Hand-mixing of concrete shall not be permitted.

Concrete Finishing: The Contractor shall be required to match the texture and color of adjacent curb and gutter to the satisfaction of the City Engineer. The finish may be brushed or washed to expose the Meramec gravel surface in an effort to match the existing curb and gutter. Sandblasting shall not be allowed. The Contractor shall be given the option of using a suitable retarder for preparing the finish if he so desires. All edges and joints shall be finished with an edging tool having a radius of 1/4 inch. Any markings or defects of any sort in the pavement shall require removal and replacement of the curb and gutter by the Contractor at his cost as directed by the City Engineer.

Curing: Curing shall be accomplished by spraying Type 1-D for concrete curb and gutter and CS-309 non yellowing acrylic curing compound for granite curb and gutter at the rate of 200 S.F. per gallon. Within thirty (30) minutes after the free water has left the pavement surface, the entire surface shall be sealed by hand or machine spraying with a uniform application of curing compound. The Contractor shall follow manufacturer's recommended specifications. Type 1-D liquid membrane-forming curing compounds shall be in accordance with AASHTO M 148 for Type 1-D, clear or translucent with fugitive dye. Type 1 curing compounds are applied to curbs, concrete medians, median strips, sidewalks (non-exposed aggregate), steps, and paved approaches. Pink or white pigmented curing compounds are not acceptable due to the discoloration that occurs.

Deviations: Finished curb shall present a uniform appearance for both grade and alignment. Any section of curb showing abrupt changes in alignment or grade, which is more than 1/4 inches away from its location as staked or exhibits a deviation of more than 1/4" within a ten-foot segment, shall be removed and replaced at the Contractor's sole expense.

Match Existing Structures: Where the curb meets the existing curb or curb ramps, the Contractor shall be required to meet grade and provide a smooth transition. The City Engineer shall determine the location of the joint.

Backfill & Restoration

General: Backfilling shall take place within 5 days of the form removal and shall be clean topsoil. Clean topsoil shall be deemed as topsoil free of clay, rocks, weeds, subsoil or foreign material including stumps, roots, brush, etc. Any material found unacceptable by the City Engineer shall be rejected. All topsoil backfill shall be compacted by the use of vibratory compaction plates and/or sheepsfoot pneumatic equipment. Contractor shall be required to sod or restore landscaping to existing conditions the backfill areas as directed by the City Engineer. All sodding shall match the existing species of grass. Backfill, sodding and landscape restoration shall be considered incidental work. No separate payment shall be made for this work.

4.0 Measurement

Vertical Concrete Curb and Gutter, Type A (8-inch): The quantity of vertical concrete curb and gutter shall be measured as the number of linear feet, including concrete base and 4" aggregate base, in place, completed and accepted by the City Engineer.

5.0 Payment

Payment for Vertical Concrete Curb and Gutter, Type A (8-inch) shall be full compensation for furnishing all required labor and materials to complete the Work per these specifications and will be paid for at the contract unit price per linear feet.

No direct payment will be made for sawcutting, concrete base, or Type 1 aggregate base. These items shall be considered incidental to Removal of Improvements and the construction of the Concrete Curb and Gutter.

S. ROADWAY SIGNS

1.0 Description.

Where called for on the plans, or as instructed by the City Engineer, install appropriate Roadway Signs.

All permanent signage outside the pavement limits shall be mounted with U-channel posts or on existing light, utility poles, or parking meters as noted. All signs specified to be either installed or removed and replaced within the pavement limits (i.e. within medians or islands) shall be mounted using breakaway posts. All signs shall be in accordance with the Manual on Uniform Traffic Control Devices (MUTCD). Any signs not detailed on the plans shall be in accordance with current version of Standard Highway Signs by the U.S. Department of Transportation, Federal Highway Administration.

2.0 Materials

Sign Material shall conform to the Missouri Standard Specifications for Highway Construction, Division 1000 Materials Details, specifically:

Section 1036 – Reinforcing Steel for Concrete Section
1042 – Highway Sign Material

Section 1080 – Low-Carbon Steel Bolts, Nuts, and Washers

Section 1081 – Galvanized Coating of Structural Steel, Tubular Steel Sign
Supports, Sign Trusses and Appurtenances

U-Channel post shall be in accordance with ASTM A 499, Grade 60.

Banding Material:

- Color – Silver (or color specified by the engineer)
- For installation on a 4" to 12"D Post
- Length 36"
- +4SS Flared Leg Brackets, 5/16 x 5/8" Hex Head Bolts, 3/8" Nylon Washers, (2) End Pieces, 36" Pre-Cut Straps, 5/16 x 1-3/4" Hex Head Bolts, 5/16" Hex Nuts

3.0 Execution

Contractor shall carefully install Roadway Signs as indicated on the plans and at locations designated by Engineer. Contractor shall verify the location of each Roadway Sign to be installed, as well as how they are to be attached to an existing post, or use a new channel post.

All materials and construction requirements shall conform to the current edition of the Missouri Standard Specifications for Highway Construction. (Section 903).

Sign assemblies with 10 square feet or less of signage shall be mounted on a single U-channel post. Sign assemblies with more than 10 square feet shall be mounted on two U-channel posts.

4.0 Method of Measurement

“Roadway Signs” complete shall be measured by each and shall include fabrication of the sign and all labor, equipment, materials, etc. necessary to install the “Roadway Signs”.

This work shall include all labor and equipment necessary to erect Roadway Signs on existing street light posts (Banded), signal Posts (Banded) of existing sign posts, or on new Ground Mounted Sign Posts. There will be no distinction made between the type of post used for individual signs or the various mounting techniques required or specified on the plans.

All mounting techniques shall be considered incidental to the unit bid price.

5.0 Basis of Payment

Payment for “Roadway Signs” will be made per each at the contract unit bid price and paid for per the respective bid item name.

T. PAVEMENT MARKINGS AND SYMBOLS

1.0 Description.

This work shall consist of furnishing and installing the permanent pavement marking with drop-on glass beads and pavement marking symbols as shown on the plans, as specified herein, or as directed by the Project Engineer.

2.0 Materials

High Build Waterborne Pavement Marking Paint and Drop-On Glass Beads shall conform to the MoDOT Standard Specification Section 1048.40.

High Build Waterborne Paint. High build waterborne paint shall be applied to a wet thickness of no less than 25 mils. The mil thickness shall be increased as needed to account for the porosity

of the pavement and to achieve a target bead embedment of 60%. The wet film thickness of the applied paint shall be tested by the contractor with a paint thickness gauge or by other methods approved by the engineer.

Type L drop-on glass beads, in accordance with Sec 620.30, shall be used for high build waterborne paint applications.

Blue Pavement marking material for accessible parking spaces must anti-skid and Federal Standard color 15090.

3.0 Execution

All construction requirements shall conform to MoDOT Standard Specification Section 620.

Contractor shall carefully prepare paved surfaces and install Pavement Marking as indicated on the plans and at locations designated by Engineer. Contractor shall verify the location of each Pavement Marking to be installed.

Contractor to utilize Public Works Department marking stencils at time of construction. Wording and symbol stencils are available from the municipal garage at 8300 Shaw Park Dr., contact Mike Leady at 314-290-8550. **If the city does not have a required stencil, the the contractor shall supply the stencil(s) and the city shall retain them following the project (for future maintenance).**

4.0 Method of Measurement

4 IN. White High Build Waterborne Pavement Marking Paint, Type L Beads, 4 IN. Yellow High Build Waterborne Pavement Marking Paint, Type L Beads, 12 IN. White High Build Waterborne Pavement Marking Paint, TYPE L BEADS, and 24 IN. White High Build Waterborne Pavement Marking Paint, Type L Beads complete, shall be measured by the linear foot, and shall include all labor and materials necessary.

Pavement Marking, Left Turn Arrow, Pavement Marking, Right Turn Arrow, Pavement Marking, Through Arrow, Pavement Marking, Combination Straight Left, Pavement Marking, Combination Straight Right, Pavement Marking, Bicycle Shared Lane Symbol, Accessible Parking Space Pavement Marking, And Pavement Marking Word "Stop" shall be measured per each, and shall include all labor and materials necessary.

5.0 Basis of Payment

The accepted quantity of pavement markings will be paid for at the contract unit price for each of the pay items included in the contract.

U. CONCRETE SIDEWALKS, CURB RAMPS, AND DETECTABLE WARNING SURFACE

1.0 Description. This work shall consist of the construction of Portland Cement Concrete Sidewalks and Curb Ramps, on a prepared subgrade in accordance with these specifications and in conformity with the lines, grades, thicknesses and typical cross sections shown on the plans or established by the City Engineer. Median cut-thru's shall be considered the same as curb-ramps for the purposes of materials, execution and any other applicable specifications.

Related Documents: Drawings and general provisions of Contract, including General and Supplementary Conditions and Job Special Provisions, apply to this section.

2022 St. Louis County Standard Specifications for Road and Bridge Construction shall be considered the Standard Specification. Except as noted in these specifications, all specified material, labor and equipment under this section shall comply with the latest edition of the St. Louis County Standard Specifications for Road and Bridge Construction including but not limited to section 608, and division 1000.

Submittals: Provide samples, copies of manufacturer's product data, test reports, and materials' certifications signed by material producer and Contractor, certifying that each material item complies with, or exceeds, specified requirements as required by the City Engineer.

2.0 Materials

Mix Design: The mix design is subject to review and approval by the City Engineer no later 14 days prior to first use. Any change in the mix design shall require approval by the City Engineer.

Aggregate: All Portland Cement Concrete (PCC) shall contain Meramec sand and gravel (maximum size 1") unless otherwise specified by the City Engineer. **PCC WITH LIMESTONE AGGREGATE SHALL NOT BE ACCEPTED. ALL PCC POURED WITH LIMESTONE AGGREGATE SHALL BE REMOVED AND REPLACED WITH THE APPROVED MIX WITHOUT ANY COMPENSATION FOR THE PCC WITH LIMESTONE AGGREGATE, ITS REMOVAL AND DISPOSAL.**

Cement: All concrete shall be Class A with Type 1 cement.
All sidewalks shall contain 6 sacks of cement per CY.
All curb ramps shall contain 8 ½ sacks of cement per CY.

Water: The maximum water per sack shall be 5 ¼ gallons.

Slump: All PCC for sidewalks shall have a maximum slump of 4 inches based on AASHTO T 119. All PCC for curb ramps shall have a maximum slump of 3 ½ inches based on AASHTO T 119. A tolerance of ±½ inch may be permitted.

Air-Entrained: Air-entrained concrete shall be used for all construction with a 5 ½ % air content (by volume) specified. A tolerance of ±1 ½ % (by volume) may be permitted. The City Engineer may request and shall receive adjustments to the air content, in order to affect

the serviceability of the concrete. Air content will be determined by the pressure method as specified in AASHTO T 152.

Admixtures: The use of admixtures not herein specified is prohibited unless the City Engineer grants prior approval.

Strength: All sidewalks shall have a minimum compression strength of 3,500 psi at twenty-eight (28) days. All curb ramps shall have a minimum compressive strength of 3,500 psi at three (3) days and a minimum compressive strength of 4,500 psi at twenty-eight days. Compressive strength will be determined from samples prepared and tested by the City Engineer in accordance with ASTM C31-86 and ASTM C39-86.

Color & Finish: Contractor shall take measures match adjacent sidewalk in color and finish. Sidewalks & driveway approaches shall be a surface applied control set or other method to match neighboring pavement (lightly expose Meramec sand and gravel in most cases). Contractor shall add pigment to match color of existing concrete as directed by the City Engineer. This work shall be considered incidental to this construction.

Joint Filler: Expansion joint material shall be 1/2 inch thick pre-molded expansion joint filler. Furnish expansion joint fillers in one-piece lengths for the full width being placed.

Caulking: Caulking material (for around tiles) shall be in accordance with manufacturer's recommendations.

Curing Compound: Type 1-D liquid membrane-forming curing compounds shall be in accordance with AASHTO M 148 for Type 1-D, clear or translucent with fugitive dye.

Detectable Warning: Vanguard Detectable Warning is to be installed per the manufacturer's recommendations.

Color: The color to be used is a custom color that shall be approved by the City Engineer before installation of detectable warnings.

Aggregate Base: Aggregate base course for bedding shall conform with Section 1007 of the St. Louis County Standard Specifications. Aggregate base shall be Type 1.

Equipment

General: All equipment and tools necessary for handling material and performing all parts of work shall be satisfactory to the City Engineer as to design, capacity and mechanical condition.

Forms: Coat forms with a non-staining form release agent that will not discolor or deface surface of concrete. Forms shall be placed on a prepared subgrade of uniform density. Forms shall be metal or sound dressed lumber, straight, free from warp, of sufficient strength to resist distortion during construction and of a height equal to the full depth of the pavement to be constructed. Wood forms shall have a minimum nominal thickness of two inches except where flexible forms are used. No section shall show a variation greater than 1/8 inch in 10 feet from the true plane surface on the top and 1/4 inch in 10 feet along the face of the form. Flexible forms shall be securely staked, braced and held to the required line and grade. The method of connecting form

sections shall ensure a tight, neat joint. All forms shall be clean and coated with a form release agent before concrete placement.

Vibrators: Vibrators used shall be of the internal type. They shall not come in contact with the reinforcement, load transfer devices, subgrade or side forms.

Concrete Saw: If sawed joints are required, equipment shall be provided complete with either an abrasive wheel or a diamond-edge water-cooled blade, capable of providing a groove of the specified dimensions in the hardened concrete. Contractor shall be responsible for dust control to prevent damage to surrounding property.

3.0 Execution

Removal of Existing Sidewalk: The Contractor shall remove and dispose of designated portions of the existing PCC Sidewalk and Curb Ramp as shown on the plans or directed by the City Engineer. The existing sidewalk shall be removed to the nearest expansion joint or separated from the portion to remain by way of a full-depth sawcut. If sawcut, the cut shall be full-depth, straight, and smooth. The Contractor shall exercise care to protect the portions of the sidewalk that to remain. Damaged sidewalk that is designated to be used in place shall be removed and replaced by the Contractor at no expense to the City.

Removal of Existing Concrete Sidewalks and Curb Ramps shall be included in Removal of Improvements.

Damage: The Contractor's removal operation shall not cause damage to utilities, drainage structures, buried pet containment fences or sprinkler systems. Any damage shall be repaired by the Contractor at no expense to the City.

Sub-base: Sub-base surface shall be compacted prior to pouring any concrete using vibratory compaction plates and/or sheepsfoot pneumatic equipment. Remove loose material from compacted sub-base surface immediately before placing concrete. Do not order concrete until the City Engineer has approved the compacted subbase and inspected all forms.

Utility Adjustments: This work shall consist of locating and adjusting utility boxes and manholes as needed. This work shall be considered incidental.

Thickness: Sidewalks shall be reinstalled in the same configuration as the existing sidewalk, or as shown in the plans, and shall be five inches (5") thick. Curb ramps shall be put back in the same configuration as the existing ramps, or as shown in the plans, and shall be seven inches (7") thick.

Joints: **ALL JOINT LAYOUTS SHALL BE APPROVED BY THE CITY ENGINEER PRIOR TO ORDERING CONCRETE.** Linear joints shall be straight and true. No joint shall show a variation greater than 1/8 inch in 10 feet. All joints shall be spaced to square the slabs into areas no larger than 15'x15' or as directed by the City Engineer. Control joints shall be tooled or cut to a depth of ¼ the thickness of the slab. Vertical curbs installed as part of curb ramps shall have tooled joints and generally match the sidewalk. Expansion joints shall be installed the full width and depth along edges that abut concrete curbs, sidewalk, or any type of structure. Expansion joint fillers

shall not be less than 1/2 inch nor more than 1 inch below finished surface where joint sealer is indicated. Joint shall be tooled on curbs within curb ramps to match the joint location in the sidewalk. Install TripStop (or approved equal) control joints at locations as directed by the City Engineer according to manufacturer's recommended procedures.

Form Construction: Set forms to required grades and lines, braced and secured. Install forms to allow continuous progress of work and so that forms can remain in place at least 24 hours after concrete placement. Clean forms after each use and coat with form release agent as required ensuring separation from concrete without damage.

Concrete Placement: Do not place concrete until sub-base and forms have been checked by the City Engineer for line and grade. Moisten sub-base, if required, to provide a uniform dampened condition at time concrete is placed.

Place concrete by methods that prevent segregation of mix. Concrete shall be consolidated by vibrating the mixture promptly following placement. Consolidate concrete along face of forms and adjacent to transverse joints with internal vibrator. Use only square-faced shovels for hand spreading and consolidation.

Cold Weather Placement: Mixing and concreting operations shall be discontinued when a descending ambient temperature away from artificial heat reaches 40 degrees Fahrenheit and not resumed until an ascending ambient temperature away from artificial heat reaches 35 degrees Fahrenheit. Concrete shall not be placed on subgrade with a temperature less than 35 degrees Fahrenheit. Concrete temperature shall not drop below 65 degrees Fahrenheit for a period of no less than 6 days after placement. Concrete exposed to melting snow during daytime and freezing during nighttime shall be protected from freezing until strength of at least 3500-psi has been attained and the City Engineer has received supporting documentation.

If approval has been granted for the Contractor to place the concrete while the ambient temperature is at or lower than 40 degrees Fahrenheit, the contractor shall take precautionary measures to prevent damage by freezing, such as heating mixing water, heating aggregates, or applying heat directly to the contents of the mixer. Aggregates shall not be heated higher than 150 degrees Fahrenheit and the temperature of the aggregates and mixing water combined shall be not higher than 100 degrees Fahrenheit, when the cement is added. Unless otherwise authorized, the temperature of the mixed concrete when heating is employed shall not be less than 50 degrees Fahrenheit and not more than 80 degrees Fahrenheit at the time of placement. Cement or fine aggregate containing lumps or crusts of hardened material or frost shall not be used. Concrete shall not be placed upon a frozen subgrade.

Hot Weather: Hot weather is any time during the concrete placement that the ambient temperature at the work site is above 95° F (35° C). In hot weather, cool all surfaces that will come in contact with the mix to below 95° F (35° C). Cool by covering with wet burlap or cotton mats, fog spraying with water, covering with protective housing, or by other approved methods. Plastic concrete temperatures up to 100° F (38° C) as placed, may be permitted provided job site conditions allow placement and finishing without excessive use of water on and/or overworking of the surface. The occurrence within 24 hours of unusual surface distress shall be cause to revert to a maximum 90° F (32° C) plastic concrete temperature.

Water: Additional water shall not be added to the concrete mix once it leaves the batch plant without the approval of the City Engineer.

Hand-Mixing: Hand-mixing of concrete shall not be permitted.

Concrete Finishing: The Contractor shall be required to match the texture and color of adjacent pavement to the satisfaction of the City Engineer. The finish may be brushed or washed to expose the Meramec gravel surface in an effort to match the existing pavement. Sandblasting shall not be allowed. The Contractor shall be given the option of using a suitable retarder for preparing the finish if he so desires. All edges and joints shall be finished with an edging tool having a radius of 1/4 inch. Do not remove forms for 24 hours after concrete has been placed. After form removal, clean ends of joints and point-up any minor honeycombed areas. Any markings or defects of any sort in the pavement shall require removal and replacement of the pavement by the Contractor at his cost as directed by the City Engineer.

Curing: Curing shall be accomplished by spraying Type 1-D curing compound at the rate of 200 S.F. per gallon. Within thirty (30) minutes after the free water has left the pavement surface, the entire surface shall be sealed by hand or machine spraying with a uniform application of curing compound. The Contractor shall follow manufacturer's recommended specifications. Type 1-D liquid membrane-forming curing compounds shall be in accordance with AASHTO M 148 for Type 1-D, clear or translucent with fugitive dye. Type 1 curing compounds are applied to curbs, concrete medians, median strips, sidewalks (non-exposed aggregate), steps, and paved approaches. Pink or white pigmented curing compounds are not acceptable due to the discoloration that occurs.

Gutter Section: Where curb ramps are to be removed and replaced, a full-depth, straight, smooth saw cut shall be required in front (street side) of the ramp two feet (2') in front of the gutter line. Base concrete (8" thick) and finish asphaltic concrete (2" thick, shall be required in the two foot (2') wide gutter. The concrete gutter shall be clear of all debris, dry and prepared with a tack coat of SS-1 prior to installing the asphaltic concrete. The material, labor and equipment for the installation of the asphalt concrete shall meet the specifications of the City. The concrete and asphalt for this work shall be included in the Concrete Curb and Gutter pay item (see Section 609).

Match Existing PCC Sidewalk: Where the new sidewalk meets the existing sidewalk, the Contractor shall be required to meet grade at the nearest expansion joint or sawcut location for a smooth transition. The City Engineer shall determine the location of expansion joint or sawcut.

Detectable Warning: Install per manufacturer's recommendations. Concrete shall cure for minimum of 14 days and shall achieve a minimum compressive strength of 2500 PSI before installing Vanguard truncated domes. All "surface curing" compounds or sealers shall be removed by method of grinding before installation. Surface temperatures should not exceed 88 degrees Fahrenheit, or be below 35 degrees Fahrenheit during installation.

Vertical Curbs: At times, variable height vertical Curbs will be necessary in conjunction with curb ramps and sidewalks in order to match existing grades. These vertical curbs shall be considered part of the curb ramp or sidewalk, and be paid for at the same price/square foot (plan view) as the adjoining curb ramp or sidewalk. Vertical curb heights are labeled in the Plans

Backfill & Restoration

General: Backfilling shall take place within 5 days of the form removal and shall be clean topsoil. Clean topsoil shall be deemed as topsoil free of clay, rocks, weeds, subsoil or foreign material including stumps, roots, brush, etc. Any material found unacceptable by the City Engineer shall be rejected. All topsoil backfill shall be compacted by the use of vibratory compaction plates and/or sheepsfoot pneumatic equipment. Contractor shall be required to sod or restore landscaping to existing conditions the backfill areas as directed by the City Engineer. All sodding shall match the existing species of grass. Backfill, sodding and landscape restoration shall be considered incidental work. No separate payment shall be made for this work.

4.0 Measurement

Concrete Sidewalk (5 in. Thick): The quantity of concrete sidewalk shall be measured as the number of square feet, including 4" of Type 1 aggregate base, in place, completed and accepted by the City Engineer.

Concrete Sidewalk, Curb Ramp (7 in. Thick): The quantity of concrete curb ramp shall be measured as the number of square feet, including 4" of Type 1 aggregate base, in place, completed and accepted by the City Engineer.

Detectable Warning Surface: The quantity of detectable warning surface shall be measured as the number of square feet in place, completed and accepted by the City Engineer.

5.0 Payment

Payment for Concrete Sidewalk (5 in. Thick) shall be full compensation for furnishing all required labor and materials to complete the Work per these specifications and will be paid for at the contract unit price per square yard.

Payment for Concrete Sidewalk, Curb Ramp (7 in. Thick) shall be full compensation for furnishing all required labor and materials to complete the Work per these specifications and will be paid for at the contract unit price per square yard.

Payment for Detectable Warning Surface shall be full compensation for furnishing all required labor and materials to complete the Work per these specifications and will be paid for at the contract unit price per square foot.

No direct payment will be made for sawcutting or Type 1 aggregate base. These items shall be considered incidental to construction of the concrete sidewalk and shall be included in the contract unit price for Concrete Sidewalk (5 in. thick) and Concrete Sidewalk, Curb Ramp (7 in. thick).

V. BRICK PAVER CROSSWALK

1.0 Description This work shall consist of the installation of the bituminous setting bed interlocking concrete pavers, and joint sand in accordance with these specifications and in conformity with the lines, grades, thicknesses and typical cross sections shown on the plans or established by the City Engineer.

Related Documents: Drawings and general provisions of Contract, including General and Supplementary Conditions and Job Special Provisions, apply to this section.

American Society for Testing and Materials (ASTM):

ASTM C 33: Standard Specification for Concrete Aggregates.

ASTM C 136: Standard Test Method for Sieve Analysis of Fine and Coarse Aggregates.

ASTM C 140: Standard Test Methods for Sampling and Testing Concrete Masonry Units and Related Units.

ASTM C 144: Standard Specification for Aggregate for Masonry Mortar.

ASTM C 936: Standard Specification for Solid Concrete Interlocking Paving Units.

ASTM C 979: Pigments for Integrally Colored Concrete.

ASTM D 698: Standard Test Method for Laboratory Compaction Characteristics of Soil Using Standard Effort (12,000 ft-lbf/ft³ (600 kN-m/m³)).

ASTM D 1557: Test Method for Laboratory Compaction Characteristics of Soil Using Modified Effort (56,000 ft-lbf/ft³ (2,630 kN-m/m³)).

ASTM D 2940: Specification for Graded Aggregate Material for Bases or Subbases for Highways or Airports.

Interlocking Concrete Pavement Institute (ICPI):

ICPI Tech Spec technical bulletins.

Submittals: Provide samples, copies of manufacturer's product data, test reports, and materials' certifications signed by material producer and Contractor, certifying that each material item complies with, or exceeds, specified requirements as required by the City Engineer.

Concrete pavers: Four representative full-size samples of each paver type, thickness, color, finish that indicate the range of color variation and texture expected in the finished installation. Accepted samples become the standard of acceptance for the work. Manufacturer's certification of concrete pavers by ICPI as having met applicable ASTM C 936.

Joint Stabilizer and Setting Bed: Manufacturer's catalog product data, installation instructions, and material safety data sheets for the safe handling of the specified materials and products.

Delivery, Storage, and Handling

Refer to manufacturer's ordering instructions and lead time requirements to avoid construction delays.

Delivery: Deliver materials in manufacturer's original, unopened, undamaged containers packaging with identification labels intact. Coordinate delivery and paving schedule to minimize interference with normal use of buildings adjacent to paving.

Deliver concrete pavers to the site in steel banded, plastic banded or plastic wrapped packaging capable of transfer by fork lift or clamp lift. Unload pavers at job site in such a manner that no damage occurs to the product.

Storage and Protection: Store materials protected such that they are kept free from mud, dirt, and other foreign materials. Store concrete paver cleaners and sealers per manufacturer's instructions.

Project/Site Conditions:

Environmental Requirements: Do not install pavers during heavy rain or snowfall. Do not install pavers over frozen base materials. Do not install concrete pavers on frozen or saturated sand.

Maintenance:

Extra Materials: Provide 15% of the area additional material for use by owner for maintenance and repair.

2.0 Materials

Bedding Sand:

Clean, non-plastic, free from deleterious or foreign matter, symmetrically shaped, natural or manufactured from crushed rock.

Do not use stone dust.

Do not use limestone screenings or sand for the bedding that does not conform to the grading requirements of [ASTM C 33]

Do not use mason sand, or sand conforming to [ASTM C 144] for the bedding sand.

Utilize sands that are as hard as practically available.

Sieve according to [ASTM C 136]

Bedding Sand Material Requirements: Conform to the grading requirements of [ASTM C 33] with modifications as shown below

ASTM 33

Sieve Size	Percent Passing
3/8 in.	100
No. 4	95-100
No. 8	80-100
No. 16	50-85
No. 30	25-60
No. 50	10-30
No. 100	2-10
No. 200	1

Interlocking Concrete Pavers

Manufacturers/Color: or approved equal.

Kirchner Block & Brick: Standard Series Holland Stone-Terra Cotta Blend

Unilock: Hollandstone-Rustic Red

Belgard: Holland Stone-Color to be determined based upon samples

Interlocking Concrete Paver Units:

Paver Type: Must comply with material standards set forth in ASTM C 936.

Color: Must comply with ASTM C 979.

Size: 4 inches x 8 inches x 3 1/8 inches (80mm)

Spacer Bars: Concrete pavers shall have spacer bars on each unit.

Spacer bars are recommended for mechanically installed pavers and for those in heavy vehicular traffic. Manually installed pavers shall be installed with spacer bars.

For ASTM C 936 use the following material characteristics:

Average Compressive Strength: 8,000 psi (55 MPa) with no individual unit under 7,200 psi (50 MPa).

Average Water Absorption (ASTM C 140): 5% with no unit greater than 7%.

Freeze/Thaw Resistance (ASTM C 67): Resistant to 50 freeze-thaw cycles with no greater than 1% loss of material. Freeze-thaw testing requirements shall be waived for applications not exposed to freezing conditions.

Joint Sand: Joint sand properties and gradation should conform to ASTM C 136 using gradation specifications from either C-33 or C-144 or combination of both. Sand shall not contain shale, stone dust, screening or lightweight aggregates.

Gradation - ASTM C – 33:

Sieve Size	Percent Passing
3/8 in.	100
No. 4	95-100
No. 8	80-100
No. 16	50-85
No. 30	25-60
No. 50	10-30
No. 100	2-10

Gradation - ASTM C – 144:

Sieve Size	Natural Sand	Manufactured Sand
No. 4	100	100
No. 8	95-100	95-100
No. 16	70-100	70-100
No. 30	40-75	40-75
No. 50	10-35	20-40
No. 100	2-15	10-25
No. 200	0-10	0-10

Additive Properties: Non-toxic, organic binder that is a colorless and odorless powder that binds aggregates together to produce a firm paver joint.

Geotextile Fabric: Per manufacturer's recommendations.

3.0 Execution

Examination:

Examine surfaces indicated to receive paving, with installer present, for compliance with requirements for installation tolerances and other conditions affecting performance of

interlocking concrete pavers. Do not proceed with installation until unsatisfactory conditions have been corrected.

Verify that geotextiles, concrete base edge restraint elevations and weep holes, have been placed according to drawings and specifications.

Preparation:

Vacuum clean concrete substrates to remove dirt, dust, debris, and loose particles.

Remove substances from concrete substrates that could impair bond of mortar, including curing and sealing compounds, form oil, and laitance.

Fill weep holes with pea gravel.

Apply tack coat to along joints and around weep holes.

Install geotextile fabric over joints and weep holes to keep sand from migrating.

Installation:

Setting Bed: Spread bedding sand evenly over the base course and screed to a nominal 1 inch thickness. Spread bedding sand evenly over the base course and screed rails, using the rails and/or edge restraints to produce a nominal 1 in. thickness, allowing for specified variation in the base surface.

Do not disturb screeded sand.

Screeded area shall not substantially exceed that which is covered by pavers in one day.

Do not use bedding sand to fill depressions in the base surface.

Interlocking Concrete Pavers: Do not use interlocking concrete pavers with chips, cracks, voids, discolorations, and other defects that might be visible or cause staining in finished work. Lay pavers by hand in straight courses in pattern shown on drawing SD-12. Interlocking concrete paver area shall be a running bond pattern. Surround interlocking concrete paver area with a soldier course filling gaps behind the soldier course with cut pavers by a motor driven masonry saw to provide a clean, sharp, un-chipped edge. Use full paver without cutting where possible. Hammer cutting is not acceptable. Joint bond lines shall not deviate more than $\pm 1 / 2$ in. over 50 ft. from string lines. Protect newly laid pavers with panels of plywood on which workers stand. Advance protective panels as work progresses but maintain protection in areas subject to continued movement of materials and equipment to avoid creating depressions or disrupting alignment of concrete pavers. If additional leveling of paving is required, and before treating joints, roll with power roller after sufficient heat has built up in the surface from several days of hot weather. Check and maintain alignment as often as necessary. No greater than $1 / 8$ in. difference in height between adjacent pavers. The surface elevation of pavers shall be $1 / 8$ in. to $3 / 8$ in. above adjacent drainage inlets, concrete collars

or channels. For pedestrian access routes maximum elevation should not exceed 1/4 in. (6 mm). The final surface tolerance from grade elevations shall not deviate more than $\pm 3 / 8$ in. over 10 ft. Use a straightedge, flexible straightedge or transit depending on surface slope and contours.

Joint Stabilization: Use joint sand directly from pre-mixed bags. Do not add additional sand that would alter the mix ratio. After pavers have been initially compacted, open bags on the area to be treated and sweep into joints. Next, alternatively compact and sweep until joints are full. Carefully sweep entire pavement clean to remove joint sand mixture from the paver surfaces, including chamfered areas. Excess material remaining on the surface after the mixture has been activated is difficult to remove. The paved area, including joints, should be saturated with water to activate joint sand. Care must be taken to avoid washing sand from the joints. **Do not use high pressure spray for saturating surface.** After flooding, surface area should be allowed to dry, prior to permitting traffic. Drying typically occurs within 2 to 6 hours, depending on weather conditions. Never leave joint sand residue on surface.

Protection:

After work in this section is complete, the General Contractor shall be responsible for protecting work from damage due to subsequent construction activity on the site, if applicable.

4.0 Measurement

Brick Paver Crosswalk: Measurement of concrete unit pavers shall be made by the square foot installed, completed, and accepted by the City Engineer. This shall include concrete pavers, bituminous setting bed, adhesive, joint stabilization, tools equipment and labor to complete the installation.

5.0 Payment

Payment for Brick Paver Crosswalk shall be full compensation for furnishing all required labor and materials to complete the Work per these specifications and will be paid for at the contract unit price per square yard.

W. PCC BASE FOR CONCRETE PAVERS

1.0 Description. This section includes the placement of the concrete base for the Interlocking Concrete Pavers.

Related Documents: Drawings and general provisions of Contract, including General and Supplementary Conditions and Job Special Provisions, apply to this section.

2022 St. Louis County Standard Specifications for Road and Bridge Construction shall be considered the Standard Specification. Except as noted in these specifications, all specified material, labor and equipment under this section shall comply with the latest edition of the

St. Louis County Standard Specifications for Road and Bridge Construction including but not limited to section 300, 500, and division 1000.

Sheet C9.7 of the Plans includes a typical detail (SD-12) of this work as it is to be performed.

Submittals: Provide samples, copies of manufacturer's product data, test reports, and materials' certifications signed by material producer and Contractor, certifying that each material item complies with, or exceeds, specified requirements as required by the City Engineer.

2.0 Materials

Aggregate: The material to be used in the aggregate base shall be Type 1 Aggregate, unless otherwise approved by the City Engineer.

Geotextile: Geotextile fabric shall conform with Section 1011 of the St. Louis County Standard Specifications for Highway Construction. Geotextile shall be suitable for use as a permeable separator layer.

Portland Cement Concrete: The mix design is subject to review and approval by the City Engineer no later than 14 days prior to first use. Any change in the mix design shall require approval by the City Engineer. Hand mixing of concrete will not be permitted.

Aggregate: All Portland Cement Concrete (PCC) shall contain Meramec sand and gravel (maximum size 1") unless otherwise specified by the City Engineer. **PCC WITH LIMESTONE AGGREGATE SHALL NOT BE ACCEPTED. ALL PCC POURED WITH LIMESTONE AGGREGATE SHALL BE REMOVED AND REPLACED WITH THE APPROVED MIX WITHOUT ANY COMPENSATION FOR THE PCC WITH LIMESTONE AGGREGATE, ITS REMOVAL AND DISPOSAL.**

Cement: All concrete shall be Class A with Type 1 cement. All PCC pavements shall contain 10 ½ sacks of cement.

Water: The maximum water per sack shall be 5 gallons. **No water shall be added to the concrete mix once it leaves the batch plant without the City's approval.**

Slump: All PCC shall have a maximum slump of 4 inches based on AASHTO T 119. A tolerance of ±½ inch may be permitted.

Air-Entrained: Air-entrained concrete shall be used for all construction with a 5 ½ % air content (by volume) specified. A tolerance of ±1 ½ % (by volume) may be permitted. The City Engineer may request and shall receive adjustments to the air content, in order to affect the serviceability of the concrete. Air content will be determined by the pressure method as specified in AASHTO T 152.

Admixtures: Calcium chloride accelerator in accordance with St. Louis County Specification 1054.6 will be added on-site. The use of other admixtures not herein specified is prohibited unless the City Engineer grants prior approval.

Strength: The PCC base course for concrete pavers shall have a minimum compression strength of 2,000 psi at four (4) hours, and a minimum compressive strength of 4,500 psi at

twenty-eight (28) days. Compressive strength will be determined from samples prepared and tested by the City Engineer in accordance with ASTM C31-86 and ASTM C39-86.

Joint Filler: Expansion joint material shall be 1/2 inch thick pre-molded expansion joint filler. Furnish expansion joint fillers in one-piece lengths for the full width being placed. All expansion joint material shall be 8" tall and designed such that the top portion of the material can be removed after the concrete has set to leave a 1/2" channel that is ready to be sealed. It is the responsibility of the contractor to remove and properly dispose of the excess material produced due to the formation of this 1/2" channel. The expansion joint material shall be approved by the City prior to construction beginning.

Curing Compound: Type 1-D liquid membrane-forming curing compounds shall be in accordance with AASHTO M 148 for Type 1-D, clear or translucent with fugitive dye.

Joint Sealant: Joints shall be sealed with material that shall conform with ASTM D3405 for rubberized joint sealer of Federal specification SSS1401C. Prior to the placement of any joint seal material, the Contractor shall provide a bill of material certification that the material meets the appropriate specification.

Equipment

General: All equipment and tools necessary for handling material and performing all parts of work shall be satisfactory to the City Engineer as to design, capacity and mechanical condition.

Forms: Coat forms with a non-staining form release agent that will not discolor or deface surface of concrete. Forms shall be placed on a prepared subgrade of uniform density. Forms shall be metal or sound dressed lumber, straight, free from warp, of sufficient strength to resist distortion during construction and of a height equal to the full depth of the pavement to be constructed. Wood forms shall have a minimum nominal thickness of two inches except where flexible forms are used. No section shall show a variation greater than 1/8 inch in 10 feet from the true plane surface on the top and 1/4 inch in 10 feet along the face of the form. Flexible forms shall be securely staked, braced and held to the required line and grade. The method of connecting form sections shall ensure a tight, neat joint. All forms shall be clean and coated with a form release agent before concrete placement.

Vibrators: Vibrators used shall be of the internal type. They shall not come in contact with the reinforcement, load transfer devices, subgrade or side forms.

Concrete Saw: If sawed joints are required, equipment shall be provided complete with either an abrasive wheel or a diamond-edge water-cooled blade, capable of providing a groove of the specified dimensions in the hardened concrete. Contractor shall be responsible for dust control to prevent damage to surrounding property.

3.0 Execution

General: This section shall consist of constructing non-reinforced PCC roadway pavement in accordance with Sections 501 and 502 of the St. Louis County Standard Specifications.

The PCC base shall be constructed of six inches (6") of PCC. The concrete alley pavement shall be constructed to the lines, grade and dimensions shown on the plans. The Contractor shall notify the City Engineer at least 24 hours in advance of concrete placement for inspection. Subgrade and forms shall be inspected and approved by the City Engineer before concrete can be poured.

Removal of Existing Pavement shall be included in Removal of Improvements.

Reinforcement: Metal reinforcement and load transfer devices shall be installed as specified in detail SD-12C. The Contractor will install dowels (5/8" diameter, 30" long, @ 24" centers) on transverse and longitudinal joints, in sections of existing concrete pavement which will remain. **The dowel shall be centered exactly over the joint.** The Contractor shall coordinate with the City Engineer the scheduling of this work. The Contractor shall exercise care to protect the dowels until new concrete pavement is placed.

Forms: The contractor shall not use existing pavement that is to remain in place as a form unless it is sound concrete or asphalt and prior permission has been given by the City Engineer.

Longitudinal Joints: All joints conform to Drawing C502.03, JOINTS AND CURBS, St Louis County Department of Highways and Traffic.

At locations where adjacent longitudinal concrete pavement is designated for replacement, a "Type G" longitudinal construction joint shall be installed. **The dowel shall be centered exactly over the joint.**

Sawed Joints: Pre-molded strips shall not be used in place of saw cutting joints. All joints shall be sawed according to the following: Transverse contraction joints in the pavement shall be sawed at the intervals shown on SD-12C, or as directed by the City. When the groove for poured type transverse joints is cut prior to removal of the forms, the groove shall be cut as close as is practical to the pavement edge; and the resulting crescent-shaped plug in the groove immediately adjacent to the form will be acceptable. Sawing of joints shall commence as soon as the concrete has hardened sufficiently to permit sawing without excessive raveling. All joints shall be sawed before shrinkage cracking takes place. In general, all joints shall be sawed in sequence. When a transverse joint falls within five feet of or contacts a drainage or utility structure, the joint shall be moved to either side to permit the joint to fall in the center of round structures or at the corner of rectangular structures and the joint spacing adjusted accordingly, or shall be placed as directed by the City Engineer in the field. All joints shall be placed at right angles to or radial to the centerline of the pavement unless directed otherwise.

Expansion Joints:

Utility Structures: Manhole castings within pavement limits shall be boxed as directed by the engineer in the field and surrounded by 1/2" white closed cell poly foam. All catch basins shall be separated from the pavement by 1/2 inch pre-molded expansion joint material extending completely through the curb and pavement slab. Catch basin sills shall be separated from the pavement by 1/2 inch pre-molded expansion joint material extending completely through the pavement.

Adjacent Structures: Expansion joints shall be installed between the alley and the existing driveway approaches. Expansion joints shall be placed between any building or structure when new pavement is placed adjacent to that building or structure unless directed otherwise.

Concrete Placement/Finishing: Concrete shall be finished in accordance with Section 502.10 of the Standard Specifications except as stated below. The finished concrete roadway pavement surface shall be wire-comb finished or broom finished, as directed by the City Engineer, in a transverse direction to produce a skid resistant finish.

Where indicated on the plans, the curbing shall be transitioned to accept Handicap Ramps. Bull nose and tapers shall be formed at locations shown on the plans and in accordance with the standard details.

All existing joints and exposed concrete surfaces shall be thoroughly cleaned prior to placing of any concrete.

Pavement which contains serious depressions (holding over ½ inch of water) shall be removed and replaced at the sole expense of the Contractor at the option of the City Engineer.

Concrete not providing a first-class finish will be removed and replaced at the sole expense of the Contractor at the option of the City Engineer. For marred surface areas of slightly damaged concrete that remains in the completed project, as determined by the City Engineer, a deduction of twenty-five percent (25%) of the bid price will be made for the areas affected. The damage deduction will be applied to a section of concrete from the edge of the pavement to a longitudinal joint or between transverse joints in that section of concrete affected. If the length of the damaged section is less than ten feet, the deduction will be computed for ten feet.

Curing: Curing shall be accomplished by spraying Type 1-D curing compound at the rate of 200 S.F. per gallon. Within thirty (30) minutes after the free water has left the pavement surface, the entire surface shall be sealed by hand or machine spraying with a uniform application of curing compound. The Contractor shall follow manufacturer's recommended specifications. Type 1-D liquid membrane-forming curing compounds shall be in accordance with AASHTO M 148 for Type 1-D, clear or translucent with fugitive dye. Type 1 curing compounds are applied to curbs, concrete medians, median strips, sidewalks (non-exposed aggregate), steps, and paved approaches. Pink or white pigmented curing compounds are not acceptable due to the discoloration that occurs.

A deduction of ten percent (10%) of the bid price will be made for concrete pavement not cured in strict accordance with the above method.

Joint Sealant: All joints shall be resawn to depth of 1 1/2" immediately prior to crack sealing to remove dust and contaminants for proper adhesion of joint material. Excessive moisture in the joint shall be dried by the use of a heat lance with compressed air. Joints shall be uniformly filled. Care should be taken not to overfill the joints, any excess material shall be removed from the concrete surface. All transverse and longitudinal joints are to be filled as well as curb joints, joints adjacent to buildings, structures or existing pavement and joints at storm sewers.

Cold Weather Placement: Mixing and concreting operations shall be discontinued when a descending ambient temperature away from artificial heat reaches 40 degrees Fahrenheit and not resumed until an ascending ambient temperature away from artificial heat reaches 35 degrees Fahrenheit. Concrete shall not be placed on subgrade with a temperature less than 35 degrees Fahrenheit. Concrete temperature shall not drop below 65 degrees Fahrenheit for a period of no less than 6 days after placement. Concrete exposed to melting snow during daytime and freezing during nighttime shall be protected from freezing until strength of at least 3500-psi has been attained and the City Engineer has received supporting documentation.

If approval has been granted for the Contractor to place the concrete while the ambient temperature is at or lower than 40 degrees Fahrenheit, the contractor shall take precautionary measures to prevent damage by freezing, such as heating mixing water, heating aggregates, or applying heat directly to the contents of the mixer. Aggregates shall not be heated higher than 150 degrees Fahrenheit, and the temperature of the aggregates and mixing water combined shall be not higher than 100 degrees Fahrenheit, when the cement is added. Unless otherwise authorized, the temperature of the mixed concrete when heating is employed shall not be less than 50 degrees Fahrenheit and not more than 80 degrees Fahrenheit at the time of placement. Cement or fine aggregate containing lumps or crusts of hardened material or frost shall not be used. Concrete shall not be placed upon a frozen subgrade.

Hot Weather Placement: Hot weather is any time during the concrete placement that the ambient temperature at the work site is above 95° F (35° C). In hot weather, cool all surfaces that will come in contact with the mix to below 90° F (32° C). Cool by covering with wet burlap or cotton mats, fog spraying with water, covering with protective housing, or by other approved methods. Plastic concrete temperatures up to 90° F (32° C) as placed, may be permitted provided job site conditions allow placement and finishing without excessive use of water on and/or overworking of the surface.

Inclement Weather: In order that the concrete may be properly protected against the effects of rain before the concrete is sufficiently hardened, the Contractor will be required to have available at all times materials for the protection of the edges and surface of the unhardened concrete. Failure to properly protect unhardened concrete shall constitute cause for the removal and replacement of defective pavement at the contractor's expense.

Cleanup: Wash water from mixers shall not be permitted on the subgrade and shall not be deposited in any drainage structure.

Traffic Flow: Unless otherwise approved by the City Engineer, traffic flow must be maintained at all times during construction, and all lanes must be reopened at the end of the day through the use of steel plates. Asphalt ramps must be installed on both sides of the steel plates. Where crosswalk grades do not match existing asphalt grades, temporary asphalt will be required.

4.0 Method of Measurement

PCC Base for Concrete Pavers: The quantity of PCC Base for Concrete Pavers shall be measured as the number of linear feet (cross-section is standard 10 feet wide) in place, completed, and accepted by the City Engineer.

5.0 Basis of Payment

PCC Base for Concrete Pavers: Payment shall be at the unit price per linear foot and shall be full compensation for furnishing all required labor and materials to complete the Work per these specifications. No separate payment will be made for forming, curing, sealing, sawing and finishing concrete pavement.

X. BRICK PAVER CARRIAGE STRIP

1.0 Description. This work shall consist of installing the brick paver carriage as shown in detail C-4, C-5, and C-9 on plan sheets C9.4 and C9.5.

2.0 Materials. Brick pavers samples, and all new materials needed for the this work, shall be submitted to the City for review and approval

3.0 Method of Measurement.

Brick Paver Carriage Strip: Measurement of brick paver carriage strip shall be made by the square foot installed, completed, and accepted by the City Engineer. This shall include concrete pavers, base, adhesive, joint stabilization, tools equipment and labor to complete the installation.

4.0 Basis of Payment.

Payment for Brick Paver Carriage Strip shall be full compensation for furnishing all required labor and materials to complete the Work per these specifications and will be paid for at the contract unit price per square yard.

Y. NEW STANCHION POST (INCLUDES BASE)

1.0 Description. This work pertains to the new stanchion post and concrete base at the intersections as shown on the construction plans. Work shall follow the Standard Drawings and Specifications of St. Louis County as specified with the exception that the stanchion posts shall be a “dark bronze” color to be pre-coated before delivery to site.

Submittals: Provide color samples, copies of manufacturer's product data, test reports, and materials certifications (signed by material producer and Contractor) certifying that each material item complies with, or exceeds, specified requirements as required by the City Engineer.

2.0 Materials. Material shall follow the Standard Drawings and Specifications of St. Louis County as specified with the exception that the stanchion posts shall be a “dark bronze” color to be pre-coated before delivery to site.

3.0 Method of Measurement. New Stanchion Post (Includes Base): Measurement of stanchion post shall be measured by each post installed, completed, and accepted by the City Engineer. This shall include all material, tools, equipment and labor to complete the installation.

4.0 Payment. Payment under the unit cost bid per each shall be full compensation for this work, and no additional payment will be made for color choices.

Z. SIGN RELOCATIONS

1.0 Description.

Work under this item shall consist of the removal, relocation, re-installation of existing signs at the locations shown on the construction plans.

2.0 Materials.

Existing materials and other ancillary items necessary for this work shall be used to the extent practicable. All new materials needed for the relocation shall be submitted to the City for review and approval.

3.0 Execution.

The signs shall be installed at the location detailed on the plans with approval of the Engineer.

4.0 Measurement and Payment.

No direct payment will be made to the contractor to recover the cost of equipment, labor, materials, or time required to fulfill the above provisions, unless specified elsewhere in the contract documents.

AA. WIRELESS TRAFFIC SENSORS

1.0 Description. Work under this item shall consist of removal, installation, and testing of in-pavement wireless detection systems at the locations shown in the plans.

2.0 Materials.

Sensors shall be compatible SENSYS Networks Wireless Sensors.

3.0 Execution. The contractor shall present to the Engineer prior to the pre-construction conference written documentation of the order of work related to the disruption of the existing in-pavement detector devices. Consideration will be made to minimize the anticipated down time of the existing devices. The City of Clayton staff will determine if the proposed schedule is acceptable for any devices that will be temporarily interrupted by the pavement operations.

Before any of the construction operations disrupt the existing operation of the detectors, the Contractor shall present to the Engineer certification from the manufacturer for the removal and installation of the devices in this Section.

The contractor shall exercise reasonable care in removing the old sensors and installing the new sensors.

The sensors to be removed are noted in the plans, and shall be removed from the pavement according to manufacturer's specifications. The pavement holes and surrounding disturbed areas shall be filled in and repaired with an appropriate material as approved by the engineer.

The contractor shall install new sensors and epoxy in the pavement at the exact locations and in the exact configuration as the units were prior to removal unless otherwise indicated on the plans or by the Engineer. Contractor will be responsible to install detector units in the pavement following the manufacturer recommended procedures for installation. The detector units shall not extend above the top of the pavement. A factory certified representative shall program the new sensors by aliasing them to match the sensor ID of the sensors that were removed in order to preserve the various traffic reports in SNAPS.

A factory certified representative from the supplier shall be available for on-site assistance for a minimum of two days during installation.

Develop a proposed test procedure for the installed in-pavement detectors and submit it to the Engineer for approval. Each detector shall be tested separately. Revise the proposed test procedure until it is acceptable to the Engineer.

The Contractor shall confirm to the satisfaction of the Engineer that each detector's live status is viewable through the City of Clayton's SNAPS in the Cloud before acceptance.

The Contractor shall provide all equipment and personnel needed to safely conduct the tests. Arrange for the Engineer's representative to witness the tests. Provide the Engineer a report documenting the result of the tests.

4.0 Measurement and Payment.

Measurement and payment for Existing Sensys Pucks (T.B.R. & Replaced with New) shall be complete and in place, will be made per the unit bid price per each and shall include documentation, and acceptance testing, in addition to all materials and equipment necessary to restore the system to be fully operational.

BB. ADA COMPLIANCE AND FINAL ACCEPTANCE OF CONSTRUCTED FACILITIES

1.0 Description. The contractor shall comply with all laws pertaining to the Americans with Disabilities Act (ADA) during construction of pedestrian facilities on public rights of way for this project. An ADA Checklist is provided herein to be utilized by the contractor for verifying compliance with the ADA law. The contractor is expected to familiarize himself with the plans involving pedestrian facilities and the ADA Post Construction Checklist prior to performing the work.

2.0 ADA Checklist. The contractor can locate the ADA Checklist form on the Missouri Department of Transportation website:

http://www.modot.mo.gov/business/contractor_resources/forms.htm

2.1 The ADA Checklist is intended to be a helpful tool for the contractor to use during the construction of the pedestrian facilities and a basis for the commission's acceptance of work. Prior to work being performed, the contractor shall bring to the engineer's attention any planned work that is in conflict with the design or with the requirement shown in the checklist. Situations may arise where the checklist may not fully address all requirements needed to construct a facility to the full requirements of current ADA law. In those situations, the contractor shall propose a solution to the engineer that is compliant with current ADA law using the following hierarchy of resources: 2010 ADA Standards for Accessible Design, Draft Public Rights of Way Accessibility Guidelines (PROWAG) dated November 23, 2005, MoDOT's Engineering Policy Guidelines (EPG), or a solution approved by the U.S. Access Board.

2.2 It is encouraged that the contractor monitor the completed sections of the newly constructed pedestrian facilities in attempts to minimize negative impacts that his equipment, subcontractors or general public may have on the work. Completed facilities must comply with the requirements of ADA and the ADA Checklist or have documented reasons for the non-complaint items to remain.

3.0 Coordination of Construction.

3.1 Prior to construction and/or closure on an existing pedestrian path of travel, the contractor shall submit a schedule of work to be constructed, which includes location of work performed, the duration of time the contractor expects to impact the facility and an accessible signed pedestrian

detour complaint with MUTCD Section 6D that will be used during each stage of construction. This plan shall be submitted to the engineer for review and approval at or prior to the pre-construction conference. Accessible signed detours shall be in place prior to any work being performed that has the effect of closing an existing pedestrian travel way.

3.2 When consultant survey is included in the contract, the contractor shall use their survey crews to verify that the intended design can be constructed to the full requirements as established in the 2010 ADA Standards. When 2010 ADA Standards do not give sufficient information to construct the contract work, the contractor shall refer to the PROWAG.

3.3 When consultant survey is not included in the contract, the contractor shall coordinate with the engineer, prior to construction, to determine if additional survey will be required to confirm the designs constructability.

4.0 Final Acceptance of Work. The contractor shall provide the completed ADA Checklist to the engineer at the semi-final inspection. ADA improvements require final inspection and compliance with the ADA requirements and the ADA Checklist. Each item listed in the checklist must receive either a "YES" or an "N/A" score. Any item receiving a "NO" will be deemed non-compliant and shall be corrected at the contractor's expense unless deemed otherwise by the engineer. Documentation must be provided about the location of any non-complaint items that are allowed to remain at the end of the construction project. Specific details of the non-complaint items, the ADA requirement that the work was not able to comply with, and the specific reasons that justify the exception are to be included with the completed ADA Checklist provided to the engineer.

4.1 Slope and grade measurements shall be made using a properly calibrated, 2 foot long, electronic digital level approved by the engineer.

5.0 Basis of Payment. The contractor will receive full pay of the contract unit cost for all sidewalk, ramp, curb ramp, median, island, approach work, cross walk striping, APS buttons, pedestrian heads, detectible warning systems and temporary traffic control measures that are completed during the current estimate period as approved by the engineer. Based upon completion of the ADA Checklist, the contractor shall complete any necessary adjustments to items deemed non-compliant as directed by the engineer.

5.1 No direct payment will be made to the contractor to recover the cost of equipment, labor, materials, or time required to fulfill the above provisions, unless specified elsewhere in the contract documents.

CC. LPA BUY AMERICA REQUIREMENTS

106.9 Buy America Requirement. On all federal-aid projects, the contractor's attention is directed to Title 23 CFR 635.410 Buy America Requirements. Where steel or iron products are to be permanently incorporated into the contract work, steel and iron material shall be manufactured in the USA except for "minor usage" as described herein. Furthermore, any coating process of the steel or iron shall be performed in the USA. The use of pig iron and processed, pelletized and

reduced iron ore manufactured outside of the USA will be permitted in the domestic manufacturing process for steel or iron material.

106.9.1 Any sources other than the USA as defined will be considered foreign. The required domestic manufacturing process shall include formation of ingots and any subsequent process. Coatings shall include any surface finish that protects or adds value to the product.

106.9.2 “Minor usage” of foreign steel, iron or coating processes will be permitted, provided the cost of such products does not exceed 1/10 of one percent of the total contract cost or \$2,500.00, whichever is greater. If foreign steel, iron or coating processes are used, invoices to document the cost of the foreign portion, as delivered to the project, shall be provided and the engineer’s written approval obtained prior to placing the material in any work.

106.9.3 Buy America requirements include a step certification for all fabrication processes of all steel or iron materials that are accepted per Sec 1000.

106.9.3.1 Items designated as Category 1 will consist of steel girders, piling, and reinforcing steel installed on site. Category 1 items require supporting documentation prior to incorporation into the project showing all steps of manufacturing, including coating, as being completed in the United States and in accordance with CFR Title 23 Section 635.410 Buy America Requirements. This includes the Mill Test Report from the original producing steel mill and certifications documenting the manufacturing process for all subsequent fabrication, including coatings. The certification shall include language that certifies the following. That all steel and iron materials permanently incorporated in this project was procured and processed domestically and all manufacturing processes, including coating, as being completed in the United States and in accordance with CFR Title 23 Section 635.410.

106.9.3.2 Items designated as Category 2 will include all other steel or iron products not in Category 1 and permanently incorporated in the project. Category 2 items shall consist of, but not be limited to items such as fencing, guardrail, signing, lighting and signal supports. The prime contractor is required to submit a material of origin form certification prior to incorporation into the project from the fabricator for each item that the product is domestic. The Certificate of Materials Origin form (https://epg.modot.org/forms/CM/CERTIFICATE_OF_MATERIALS_ORIGIN.pdf) from the fabricator must show all steps of manufacturing, including coating, as being completed in the United States and in accordance with CFR Title 23 Section 635.410 Buy America Requirements and be signed by a fabricator representative. The Engineer reserves the right to request additional information and documentation to verify that all Buy America requirements have been satisfied. These documents shall be submitted upon request by the Engineer and retained for a period of 3 years after the last reimbursement of the material.

DD. ADD ALTERNATE

1.0 Description. This contract requires bidders to bid on additional contract work that will be considered for award. The award of this project does not guarantee work for all add alternate items.

Routes	Proposal Section Description
CBD Resurfacing Ph1 – STP 5438(613)	Base
CBD Resurfacing Ph1 – STP 5438(613) <ul style="list-style-type: none"> • Asphalt and detector loops at S. Hanley Road 	Add Alternate A

Note: See plans for a breakdown of all quantities for each add alternate section.

2.0 Consideration of Bids. The contractor shall submit a bid for each add alternate section. The City reserves the right to award, to the lowest responsible bidder, the combination of base plus add alternate sections that will allow the most work to be completed within the City’s budget of ***(Insert Program Dollar Amount)***. If the City chooses to exercise this right, the award of add alternate sections will be selected in accordance with the following priorities:

1. Base + Add Alternate A
2. Base

2.1 The City reserves the right to award the combination of highest priority add alternate sections over the City’s budget as long as the low bidder does not change and the award of the combination of highest priority alternate sections does not exceed more than ten percent or \$250,000 of the City’s budget, whichever is less.

2.2 The City’s budget is the basis for award of add alternates but not the basis for award of the base section. The base section of the contract will be awarded or rejected in accordance with Sec 100.

2.3 The awarded bidder will be notified, on City’s website, of the City’s selection of the combination of add alternate sections to be awarded the day of the City meeting.

3.0 Bid Bond Requirements. The contractor shall be required to obtain a bid bond for 5% of the total bid amount for the base bid and all add alternates. This bid bond will be considered applicable to the proposed work for any option.

4.0 DBE Goal. The DBE contract goal percentage specified in the Request for Bid applies to work completed for the base bid and all add alternates. The DBE contract goal percentage will be considered applicable to the proposed work for any add alternate section that is awarded.

4.1 The bidder shall submit the completed “DBE Identification Submittal” information in accordance with the bid documents for the total DBE participation percentage for the base bid and all add alternates.

4.2 If the contract is awarded for less than the maximum total of all add alternates, the awarded bidder shall submit a modified “DBE Identification Submittal” form for the proportionately reduced work with the executed contract documents after award. The modified “DBE Identification Submittal” form shall specify the DBE firm(s) to be used to meet the DBE participation percentage identified in the bid submittal for the proportionately reduced work of the awarded add alternates.

4.2.1 With submittal of the modified “DBE Identification Submittal” form, the awarded bidder is not allowed to eliminate any DBE firm(s) previously identified to complete items of work for the awarded add alternates. The awarded bidder is only allowed to proportionately reduce the participation of previously identified DBE firm(s) on awarded add alternates or eliminate previously identified DBE firms for add alternates that were not awarded.

4.2.2 The failure of the awarded bidder to submit the modified “DBE Identification Submittal”, listing actual, committed DBE participation percentage equal to or greater than the DBE participation percentage specified in the bid for all add alternates, may result in the bid being declared non responsive and may result in forfeiture of the bid surety bond or bid guaranty from the bidder.

5.0 Basis of Payment. The accepted quantities of the chosen combination of base plus add alternate sections will be paid for by the contract unit bid price for item numbers found within the schedule of items for each section.

EE. MODOT SUPPLEMENTAL REVISIONS

Compliance with [2 CFR 200.216 – Prohibition on Certain Telecommunications and Video Surveillance Services or Equipment](#).

The Missouri Highways and Transportation Commission shall not enter into a contract (or extend or renew a contract) using federal funds to procure or obtain equipment, services, or systems that uses covered telecommunications equipment or services as substantial or as critical technology as part of any system where the video surveillance and telecommunications equipment was produced by Huawei Technologies Company, ZTE Corporation, Hytera Communications Corporation, Hangzhou Hikvision Digital Technology Company, or Dahua Technology Company (or any subsidiary or affiliate of such entities).

Stormwater Compliance Requirements

1.0 Description. This provision requires the contractor to provide a Water Pollution Control Manager (WPCM) for any project that includes land disturbance on the project site and the total area of land disturbance, both on the project site, and all Off-site support areas, is one (1) acre or more. Regardless of the area of Off-site disturbance, if no land disturbance occurs on the project site, these provisions do not apply. When a WPCM is required, all sections within this provision shall be applicable, including assessment of specified Liquidated Damages for failure to correct Stormwater Deficiencies, as specified herein. This provision is in addition to any other stormwater, environmental, and land disturbance requirements specified elsewhere in the contract.

1.1 Definitions. The project site is defined as all areas designated on the plans, including temporary and permanent easements. The project site is equivalent to the “permitted site”, as defined in MoDOT’s State Operating Permit. An Off-site area is defined as any location off the project site the contractor utilizes for a dedicated project support function, such as, but not limited to, staging area, plant site, borrow area, or waste area.

1.2 Reporting of Off-Site Land Disturbance. If the project includes any planned land disturbance on the project site, prior to the start of work, the contractor shall submit a written report to the engineer that discloses all Off-site support areas where land disturbance is planned, the total acreage of anticipated land disturbance on those sites, and the land disturbance permit number(s). Upon request by the engineer, the contractor shall submit a copy of its land disturbance permit(s) for Off-site locations. Based on the total acreage of land disturbance, both on and Off-site, the engineer shall determine if these Stormwater Compliance Requirements shall apply. The Contractor shall immediately report any changes to the planned area of Off-site land disturbance. The Contractor is responsible for obtaining its own separate land disturbance permit for Off-site areas.

2.0 Water Pollution Control Manager (WPCM). The Contractor shall designate a competent person to serve as the Water Pollution Control Manager (WPCM) for projects meeting the description in Section 1.0. The Contractor shall ensure the WPCM completes all duties listed in Section 2.1.

2.1 Duties of the WPCM:

- (a) Be familiar with the stormwater requirements including the current MoDOT State Operating Permit for construction stormwater discharges/land disturbance activities; MoDOT's statewide Stormwater Pollution Prevention Plan (SWPPP); the Corps of Engineers Section 404 Permit, when applicable; the project specific SWPPP, the Project's Erosion & Sediment Control Plan; all applicable special provisions, specifications, and standard drawings; and this provision;
- (b) Successfully complete the MoDOT Stormwater Training Course within the last 4 years. The MoDOT Stormwater Training is a free online course available at MoDOT.org;
- (c) Attend the Pre-Activity Meeting for Grading and Land Disturbance and all subsequent Weekly Meetings in which grading activities are discussed;
- (d) Oversee and ensure all work is performed in accordance with the Project-specific SWPPP and all updates thereto, or as designated by the Engineer;
- (e) Review the project site for compliance with the Project SWPPP, as needed, from the start of any grading operations until final stabilization is achieved, and take necessary actions to correct any known deficiencies to prevent pollution of the waters of the state or adjacent property owners prior to the engineer's weekly inspections;
- (f) Review and acknowledge receipt of each MoDOT Inspection Report (Land Disturbance Inspection Record) for the Project within forty eight (48) hours of receiving the report and ensure that all Stormwater Deficiencies noted on the report are corrected as soon as possible, but no later than stated in Section 5.0.

3.0 Pre-Activity Meeting for Grading/Land Disturbance and Required Hold Point. A Pre-Activity meeting for grading/land disturbance shall be held prior to the start of any land disturbance operations. No land disturbance operations shall commence prior to the Pre-Activity meeting except work necessary to install perimeter controls and entrances. Discussion items at the pre-activity meeting shall include a review of the Project SWPPP, the planned order of grading operations, proposed areas of initial disturbance, identification of all necessary BMPs that shall be

installed prior to commencement of grading operations, and any issues relating to compliance with the Stormwater requirements that could arise in the course of construction activity at the project.

3.1 Hold Point. Following the pre-activity meeting for grading/land disturbance and subsequent installation of the initial BMPs identified at the pre-activity meeting, a Hold Point shall occur prior to the start of any land disturbance operations to allow the engineer and WPCM the time needed to perform an on-site review of the installation of the BMPs to ensure compliance with the SWPPP is met. Land disturbance operations shall not begin until authorization is given by the engineer.

4.0 Inspection Reports. Weekly and post run-off inspections will be performed by the engineer and each Inspection Report (Land Disturbance Inspection Record) will be entered into a web-based Stormwater Compliance database. The WPCM will be granted access to this database and shall promptly review all reports, including any noted deficiencies, and shall acknowledge receipt of the report as required in Section 2.1 (f.).

5.0 Stormwater Deficiency Corrections. All stormwater deficiencies identified in the Inspection Report shall be corrected by the contractor within 7 days of the inspection date or any extended period granted by the engineer when weather or field conditions prohibit the corrective work. If the contractor does not initiate corrective measures within 5 calendar days of the inspection date or any extended period granted by the engineer, all work shall cease on the project except for work to correct these deficiencies, unless otherwise allowed by the engineer. All impact costs related to this halting of work, including, but not limited to stand-by time for equipment, shall be borne by the Contractor. Work shall not resume until the engineer approves the corrective work.

5.1 Liquidated Damages. If the Contractor fails to complete the correction of all Stormwater Deficiencies listed on the MoDOT Inspection Report within the specified time limit, the Commission will be damaged in various ways, including but not limited to, potential liability, required mitigation, environmental clean-up, fines and penalties. These damages are not reasonably capable of being computed or quantified. Therefore, the contractor will be charged with liquidated damages specified in the amount of \$2,000 per day for failure to correct one or more of the Stormwater Deficiencies listed on the Inspection Report within the specified time limit. In addition to the stipulated damages, the stoppage of work shall remain in effect until all corrections are complete.

6.0 Basis of Payment. No direct payment will be made for compliance with this provision.

Anti-Discrimination Against Israel Certification

By signing this contract, the Company certifies it is not currently engaged in and shall not, for the duration of the contract, engage in a boycott of goods or services from the State of Israel, companies doing business in or with Israel or authorized by, licensed by, or organized under the laws of the State of Israel, or persons or entities doing business in the State of Israel as defined by Section 34.600 RSMo. This certification shall not apply to contracts with a total potential value of less than One Hundred Thousand Dollars (\$100,000) or to contractors with fewer than ten (10) employees.

Ground Tire Rubber (GTR) Dry Process Modification of Bituminous Pavement Material

1.0 Description. This work shall consist of the dry process of adding ground tire rubber (GTR) to modify bituminous material to be used in highway construction. Existing GTR requirements in Section 1015 pertain to the wet process method of GTR modification that blends GTR with the asphalt binder (terminal blending or blending at HMA plant). The following requirements shall govern for dry process GTR modification. The dry process method adds GTR as a fine aggregate or mineral filler during mix production. All GTR modified asphalt mixtures shall be in accordance with Secs 401, 402, or 403 as specified in the contract; except as revised by this specification.

2.0 Materials. The contractor shall furnish a manufacturer’s certification to the engineer for each shipment of GTR furnished stating the name of the manufacturer, the chemical composition, workability additives, and certifying that the GTR supplied is in accordance with this specification.

2.1 Product Approval. The GTR product shall contain a Trans-Polyoctenamer (TOR) added at 4.5 % of the weight of the crumb rubber or an engineered crumb rubber (ECR) workability additive that has proven performance in Missouri. Other GTR additives shall be demonstrated and proven prior to use such as a five-year field performance history in other states or performance on a federal or state-sanctioned accelerated loading facility.

2.2 General. GTR shall be produced from processing automobile or truck tires by ambient or cryogenic grinding methods. Heavy equipment tires, uncured or de-vulcanized rubber will not be permitted. GTR shall also meet the following material requirements:

Table 1 – GTR Material Properties		
Property	Test Method	Criteria
Specific Gravity	ASTM D1817	1.02 to 1.20
Metal Contaminates	ASTM D5603	≤ 0.01%
Fiber Content	ASTM D5603	≤ 0.5%
Moisture Content	ASTM D1509	≤ 1.0%*
Mineral Filler	AASHTO M17	≤ 4.0%

*Moisture content of the GTR shall not cause foaming when combined with asphalt binder and aggregate during mix production

2.3 Gradation. The GTR material prior to TOR or ECR workability additives shall meet the following gradation and shall be tested in accordance with ASTM D5603 and ASTM D5644.

Table 2 – GTR Gradation	
Sieve	Percent Passing by Weight
No. 20	100
No. 30	98-100
No. 40	50-70
No. 100	5-15

3.0 Delivery, Storage, and Handling. The GTR shall be supplied in moisture-proof packaging or other appropriate bulk containers. GTR shall be stored in a dry location protected from rain before use. Each bag or container shall be properly labeled with the manufacturer's designation for the GTR and specific type, mesh size, weight and manufacturer's batch or Lot designation.

4.0 Feeder System. Dry Process GTR shall be controlled with a feeder system using a proportioning device that is accurate to within ± 3 percent of the amount required. The system shall automatically adjust the feed rate to always maintain the material within this tolerance and shall have a convenient and accurate means of calibration. The system shall provide in-process monitoring, consisting of either a digital display of output or a printout of feed rate, in pounds per minute, to verify feed rate. The supply system shall report the feed in 1-pound increments using load cells that will enable the user to monitor the depletion of the GTR. Monitoring the system volumetrically will not be allowed. The feeder shall interlock with the aggregate weight system and asphalt binder pump to maintain correct mixture proportions at all production rates.

Flow indicators or sensing devices for the system shall be interlocked with the plant controls to interrupt mixture production if GTR introduction rate is not within ± 3 percent. This interlock will immediately notify the operator if GTR introduction rate exceeds introduction tolerances. All plant production will cease if the introduction rate is not brought back within tolerance after 30 seconds. When the interlock system interrupts production and the plant has to be restarted, upon restarting operations; the modifier system shall run until a uniform feed can be observed on the output display. All mix produced prior to obtaining a uniform feed shall be rejected.

4.1 Batch Plants. GTR shall be added to aggregate in the weigh hopper. Mixing times shall be increased per GTR manufacturer recommendations.

4.2 Drum Plants. The feeder system shall add GTR to aggregate and liquid binder during mixing and provide sufficient mixing time to produce a uniform mixture. The feeder system shall ensure GTR does not become entrained in the exhaust system of the drier or plant and is not exposed to the drier flame at any point after introduction.

5.0 Testing During Mixture Production. Testing of asphalt mixes containing GTR shall not begin until at least 30 minutes after production or per additive supplier's recommendation.

6.0 Construction Requirements. Mixes containing GTR shall have a target mixing temperature of 325 F or as directed by the GTR additive supplier. The additive supplier's recommendations shall be followed to allow for GTR binder absorption/reaction. This may include holding mix in the silo to allow time for binder to absorb into the GTR. Rolling operations may need to be modified.

7.0 Mix Design Test Method Modification. A formal mixing procedure from the additive supplier shall be provided to the contractor and engineer that details the proper sample preparation, including blending GTR with the binder or other additives. Samples shall be prepared and fabricated in accordance with this procedure by the engineer and contractor throughout the duration of the project.

8.0 Mix design Volumetrics. Mix design volumetric equations shall be modified as follows:

8.1 Additional virgin binder added to offset GTR absorption of binder shall be counted as part of the mix virgin binder

8.2 GTR shall be included as part of the aggregate when calculating VMA of the mix.

8.2.1 GTR SPG shall be 1.15

8.3 Mix G_{sb} used to determine VMA shall be calculated as follows:

$$G_{sb (JMF)} = \frac{(100 - P_{bmv})}{\left(\frac{P_s}{G_{sb}} + \frac{P_{GTR}}{G_{GTR}}\right)}$$

where:

$G_{sb (JMF)}$ = bulk specific gravity of the combined aggregate including GTR

P_{bmv} = percent virgin binder by total mixture weight

P_s = percent aggregate by total mixture weight (not including GTR)

P_{GTR} = percent GTR by total mixture weight

G_{sb} = bulk specific gravity of the combined aggregate (not including GTR)

G_{GTR} = GTR specific gravity

8.4 G_{se} shall be calculated as follows:

$$G_{se} = \frac{(100 - P_b - P_{GTR})}{\left(\frac{100}{G_{mm}} - \frac{P_b}{G_b} - \frac{P_{GTR}}{G_{GTR}}\right)}$$

8.5 P_{be} shall be calculated as follows:

$$P_{be} = P_b - \frac{P_{ba}}{100} * (P_s + P_{GTR})$$

9.0 Minimum GTR Amount. The minimum dosage rate for GTR shall be 5 % by weight of total binder for an acceptable one bump grade or 10 % by weight of total binder for an acceptable two bump grade as detailed in the following table. Varying percentage blends of GTR and approved additives may be used as approved by the engineer with proven performance and meeting the specified requirements of the contract grade.

Contract Binder Grade	Percent Effective Virgin Binder Replacement Limits	Required Virgin Binder Grade	Minimum GTR Dosage Rate
PG 76-22	0 - 20	PG 70-22	5 %
		PG 64-22	10 %
PG 70-22	0 - 30	PG 64-22	5 %
		PG 58-28	10 %
PG 64-22	0 – 40*	PG 58-28	5 %
		PG 52-34	10 %
PG 58-28	0 – 40*	PG 52-34	5 %
		PG 46-34	10 %

* Reclaimed Asphalt Shingles (RAS) may be used when the contract grade is PG 64-22 or PG 58-28. RAS replacement shall follow the 2 x RAS criteria when calculating percent effective binder replacement in accordance Sec 401.

Buy America

In addition to Section 106.9 of the Missouri Standard Specifications for Highway Construction, the following requirements will also be in effect for this project.

1.0 Description. The Bipartisan Infrastructure Law (BIL) was enacted on November 15, 2021. The BIL includes Build America, Buy America Act Publication L. No. 117-58. This provision expands the Buy America requirements beyond what is currently only required for steel and iron products. The steel and iron provisions have not changed with the new bill. Cement and cementitious materials; aggregates such as stone, sand, or gravel; or aggregate binding agents or additives are excluded from this requirement. All other materials and manufactured products permanently incorporated into the project will be subject to Buy America requirements. There are three categories requiring Buy America Certification:

- a) Iron and steel – no changes to the current specification requirements.
- b) Manufactured products – these are currently exempted under the 1983 waiver from FHWA.
- c) Construction materials consisting primarily of:
 - Non-ferrous metals;
 - Plastic and polymer-based products (including polyvinylchloride, composite build materials, and polymers used in fiber optic cables);
 - Glass (including optic glass);
 - Lumber; or
 - Drywall

1.1 All products and or materials will only be classified under one of these categories and not under multiple categories. It is the prime contractor’s responsibility to assure all submittals required for Buy America are submitted to the Engineer prior to the products and or materials being incorporated in the job. The implementation of this policy will be in effect for all projects awarded after November 10, 2022.

1.2 New items designated as construction materials under this requirement will require the prime contractor to submit a material of origin form certification prior to incorporation into the project. The Certificate of Material origin form ([link to certificate form](#)) from the supplier and/or fabricator must show all steps of the manufacturing being completed in the United States. The Certificate of Material form shall be filed with the contract documents.

1.3 Any minor miscellaneous construction material items that are not included in the materials specifications shall be certified by the prime contractor as being procured domestically. The certification shall read “I certify all materials permanently incorporated in this project covered under this provision have been to the best of my knowledge procured and all manufactured domestically.” The certification shall be signed by an authorized representative of the prime contractor.

1.4 The National Transportation Product Evaluation Program (NTPEP) compliance program verifies that some non-iron and steel products fabrication processes conform to 23 CFR 635.410 Buy America Requirements and an acceptable standard per 23 CFR 635.410(d). NTPEP compliant suppliers will not be required to submit step certification documentation with the shipment for some selected non-iron and steel materials. The NTPEP compliant supplier shall maintain the step certification documentation on file and shall provide this documentation to the engineer upon request.

2.0 Basis of Payment. Any costs incurred by the contractor by reason of compliance with the above requirements shall be considered as included in and completely covered by the unit price bid for the various items of work included in the contract.

Delete Sec 403.19.2 and substitute the following:

403.19.2 Lots. The lot size shall be designated in the contractor’s QC Plan. Each lot shall contain no less than four sublots and the maximum subplot size shall be 1,000 tons. The maximum lot size shall be 4,000 tons for determination of pay factors. Sublots from incomplete lots shall be combined with the previous complete lot for determination of pay factors. When no previous lot exists, the mixture shall be treated in accordance with [Sec 403.23.7.4.1](#). A new lot shall begin when the asphalt content of a mixture is adjusted in accordance with [Sec 403.11](#).

FF. EMULSIFIED MALTENE-BASED REJUVENATOR

1.0 Description:

This work shall consist of furnishing all labor, material and equipment necessary to perform the operations for the application of an Emulsified Maltene-Based Asphalt Rejuvenating Agent to

bituminous asphaltic surface courses. The rejuvenation of surface courses shall be by spray application of a cationic Maltene-Based Rejuvenating Agent composed of petroleum oils and resins emulsified with water. The base used for the emulsion shall be a naphthenic base stock. The asphalt binder rejuvenation shall be affected through maltene replacement technology. All work shall be in accordance with the specifications, any applicable drawings, and subject to the terms and conditions of this contract.

Submittals: The Contractor shall present samples of materials, laboratory reports, calibration reports, and proof of work experience as required by these specifications to the Resident Engineer at the pre-construction meeting.

The Contractor shall employ operators, foremen and other personnel directly involved in the asphalt rejuvenator placement that each has a minimum of 3 years of experience in the application of asphalt rejuvenator. The Contractor may submit a request to the Engineer detailing a formal training program that the personnel have received if his personnel have less than three years individual experience with the placement of UBWC.

No Notice to Proceed will be granted until all of the following has been submitted to the Engineer.

- Laboratory Mix design and all supporting test reports on aggregate, binder and emulsion,
- Samples of binder, anti-strip and aggregate materials,
- Equipment calibration reports,
- Personnel experience and project experience information

2.0 Material:

The emulsion shall be a naphthenic petroleum maltene-based rejuvenating agent composed of four petroleum maltene components (listed below) uniformly emulsified with water. Each bidder must submit with his bid a certified statement from the asphalt rejuvenator manufacturer showing that the asphalt rejuvenating emulsion conforms to the required physical and chemical requirements.

<u>Tests</u>	Test Method		Requirements	
	<u>ASTM</u>	<u>AASHTO</u>	<u>Min.</u>	<u>Max.</u>
Tests on Emulsion:				
Viscosity @ 25°C, SFS	D-244	T-59	15	40
Residue, % W ¹	D-244(Mod.)	T-59(Mod)	60	65
Miscibility Test ²	D-244(Mod.)	T-59(Mod)	No Coagulation	
Sieve Test, %W ³	D-244(Mod.)	T-59(Mod)	-	0.1
Particle Charge Test	D-244	T-59	Positive	
Percent Light Transmittance ⁴	GB	GB	-	30

Tests on Residue from Distillation:

Flash Point, COC, °C	D-92	T-48	196	-
Viscosity @ 60°C, cSt	D-445	-	100	200
Asphaltenes, %w	D-2006-70	-	-	1
Maltene Dist. Ratio	D-2006-70	-	0.3	0.6
	$\frac{PC + A_1^5}{S + A_2}$			
PC/S Ratio ⁵	D-2006-70	-	0.5	-
Saturated Hydrocarbons, S ⁵	D-2006-70	-	21	28

¹ ASTM D-244 Modified Evaporation Test for percent of residue is made by heating 50 gram sample to 149 C (300 F) until foaming ceases, then cool immediately and calculate results.

² Test procedure identical with ASTM D-244-60 except that .02 Normal Calcium Chloride solution shall be used in place of distilled water.

³ Test procedures identical with ASTM D-244-60 except that distilled water shall be used in place of two percent sodium oleate solution.

⁴ Test procedure is attached.

⁵ Chemical composition by ASTM Method D-2006-70:

PC = Polar Compounds, A₁ = First Acidaffins
A₂ = Second Acidaffins, S = Saturated Hydrocarbons

Material Performance: The asphalt rejuvenating agent shall have the capability to penetrate the asphalt pavement surface and perform as follows. The asphalt rejuvenating agent shall be absorbed and incorporated into the asphalt binder. Verification that said incorporation of the asphalt rejuvenating agent into the asphalt binder has been effected shall be by analysis of the chemical properties of said asphalt binder i.e. viscosity shall be reduced by petroleum maltene fraction replacement method to the following extent. For pavements receiving the first or original application of rejuvenating agent the viscosity shall be reduced by an AVERAGE of thirty-five, (35%) percent as determined by dynamic shear rheometer (DSR) method for asphalt testing in accord with AASHTO T315-05. For retreated pavements after an initial treatment with the asphalt rejuvenator the viscosity shall be reduced by petroleum maltene replacement method a minimum of twenty percent(20%)as determined by dynamic shear rheometer (DSR) method for testing in accord with AASHTO T315-05. In addition the phase angle shall be increased. This analysis shall apply to extracted asphalt binder, taken from cores extracted fifteen to thirty days following application, in the upper three eights inch (3/8”) of pavement. In addition the treated areas shall be sealed in-depth to the intrusion of air and water.

When directed by the Engineer, the Contractor shall have the following additional testing performed at the cost of the owner. The extracted asphalt binder taken from the treated and untreated cores as heretofore outlined shall be further tested per ASTM D-2006-70 Rostler Analysis. The results of this testing shall indicate a decrease in the percent asphaltene content for the treated samples as compared to the untreated samples.

The bidder must submit with their bid:

- Asphalt Rejuvenator product name and descriptive literature. Literature shall be descriptive and detailed information and shall show it at least meets the material specifications.
- A current Material Safety Data Sheet (SDS) for the material showing Current CAS#'s
- The manufacturer's certification that the material proposed for use is in compliance with these specification requirements.
- Previous use documentation and test data conclusively demonstrating that the rejuvenating agent has been used successfully for a period of 5 years by government agencies such as Cities, Counties, or DOT's.
- Testing data from a minimum of five projects showing that the asphalt rejuvenating agent has been proven to perform, as heretofore required, through field testing by an independent testing laboratory as to the required change in the asphalt binder viscosity and percent asphaltene content.
- Minimum of 2 physical test spots throughout state showing the products physical performance. Treatment shall be a minimum of 2 years in age showing significant surface mending, healing, and preservation qualities as compared to the adjacent control section constructed from the same asphalt mat. Detailed pictures shall be submitted with bid outlining age, location, and clear delineation between the treated and untreated section
- Written Experience outline of the project superintendent

Rejuvenator Acceptance: (Product sampling) The Engineer will take samples of the rejuvenation product proposed for use upon delivery of each shipment in accordance with ASTM D140 and store in accordance with the MSDS, Section VII for a period of at least six months after payment. Testing, as necessary, will be accomplished by the Engineer to verify information provided by the MSDS information

3.0 Execution.

Applicator Experience: The asphalt rejuvenating agent shall be applied by an experienced applicator of such material. The bidder shall have a minimum of 5 years' experience in applying the product proposed for use on municipal streets. The Contractor must submit with his bid a list of five (5) projects on which he applied said rejuvenator. He shall indicate the project dates, number of square yards treated in each and the name and phone number of the manager in charge of each project. A project superintendent knowledgeable and experienced in application of the asphalt rejuvenating agent must be present and in control of each day's work.

Application Temperature and Weather Limitations: The temperature of the asphalt rejuvenation emulsion, at the time of application shall be as recommended by the manufacturer. The asphalt rejuvenating agent shall be applied only when the existing surface to be treated is thoroughly dry. The asphalt rejuvenating agent shall not be applied when the ambient temperature is below 40 degrees Fahrenheit or when temperatures are forecasted to fall below 35 degrees Fahrenheit within twenty-four (24) hours of application. It

shall be the discretion of the Resident Engineer to determine when weather conditions are not appropriate for the application to occur. Contractor shall halt the application process when so ordered by the Resident Engineer.

Handling of Asphalt Rejuvenating Agent: Contents in tank cars or storage tanks shall be circulated at least forty-five minutes before withdrawing any material for application. When loading the distributor, the asphalt rejuvenating agent concentrate shall be loaded first and then the required amount of water shall be added. The water shall be added into the distributor with enough force to cause agitation and thorough mixing of the two (2) materials. To prevent foaming, the discharge end of the water hose or pipe shall be kept below the surface of the material in the distributor which shall be used as a spreader. The distributor truck will be cleaned of all of its asphalt materials, and washed out to the extent that no discoloration of the emulsion may be perceptible. Cleanliness of the spreading equipment shall be subject to inspection and the Contractor shall halt the application process when so ordered by the Project Engineer

Application Equipment: The distributor for spreading the emulsion shall be self-propelled, and shall have pneumatic tires. The distributor shall be designed and equipped to distribute the asphalt rejuvenating agent uniformly on variable widths of surface at readily determined and controlled rates from 0.05 to 0.5 gallons per square yard of surface, and with an allowable variation from any specified rate not to exceed five (5) percent of the specified rate. Distributor equipment shall include full circulation spray bars, pump tachometer, volume measuring device and a hand hose attachment suitable for application of the emulsion manually to cover areas inaccessible to the distributor. The distributor shall be equipped to circulate and agitate the emulsion within the tank. A check of distributor equipment as well as application rate accuracy and uniformity of distribution shall be made when directed by the Resident Engineer. The truck used for sanding shall be equipped with a spreader that allows the sand to be uniformly distributed onto the pavement. The spreader shall be able to apply 1 to 4 pounds of sand per square yard in a single pass. The spreader shall be adjustable so as to not broadcast sand onto driveways or tree lawns. Any equipment which is not maintained in full working order, or is proven inadequate to obtain the results prescribed, shall be repaired or replaced at the direction of the Resident Engineer.

Application of Rejuvenating Agent: The asphalt rejuvenating agent shall be applied by a distributor truck at the temperature recommended by the manufacturer and at the pressure required for the proper distribution. The emulsion shall be so applied that uniform distribution is obtained at all points of the areas to be treated. Distribution shall be commenced with a running start to insure full rate of spread over the entire area to be treated. Areas inadvertently missed shall receive additional treatment as may be required by a hand sprayer application. Application of the asphalt rejuvenating agent shall be on one-half width of the pavement at a time. When the second half of the surface is treated, the nozzle nearest the center of the road shall overlap the previous by at least one-half the width of the nozzle spray. In any event the construction joint of the pavement shall be treated in both passes of the distributor truck. Before spreading, the asphalt rejuvenating agent shall be

blended with water at the rate of 60% rejuvenating agent and 40% water, by volume or as specified by the manufacturer. The combined mixture of asphalt rejuvenating agent and water shall be spread at the rate of 0.05 to 0.10 gallons per square yard, or as approved by the Resident Engineer following field testing. Where more than one application is to be made, succeeding applications shall be made as soon as penetration of the preceding application has been completed and approval is granted for additional applications by the Resident Engineer. Grades or super elevations of surfaces that may cause excessive runoff in the opinion of the Resident Engineer shall have the required amounts applied in two (2) or more applications as directed. Said treatment shall be uniformly applied by a method acceptable to the Resident Engineer. Care should be taken during all rejuvenator applications to not get excessive material on the curb and gutter. Additional cleaning may be required if this occurs at the contractor's expense. After the rejuvenating emulsion has penetrated, a coating of sand shall be applied to the surface in sufficient amount to protect the traveling public as required by the Resident Engineer. The Contractor shall furnish a quality inspection report showing the source and manufacturer of asphalt rejuvenating agent. When directed by the Resident Engineer, the Contractor shall take representative samples of material for testing.

Field Testing: Viscosity and penetration testing shall be done on three different streets during the application process. Four (4) cores shall be taken at each location prior to and approximately 15-60 days following the application of the maltene-based asphalt rejuvenator. Core locations will be determined by the Project Manager and core holes shall be filled with approved mix. The top three-eighths (3/8) inch of each core shall be removed and the asphalt extracted and recovered using California Test Method 365 (CTM 365). Viscosities of the recovered asphalt binder shall be determined using the Dynamic Shear Rheometer (DSR) in accordance with AASHTO T315-05. The results from the pre-treatment and the post-treatment cores from each street shall be compared and the present change in each calculated. The average value of the pre-treatment results and the post treatment results will be used to determine the final Viscosity and phase angle. No compensation will be made for material not meeting specifications. Test indicating failure to meet the specifications may result in additional tests being required on other streets. No additional compensation will be made for additional testing. Testing shall be performed by an independent third party testing laboratory that has experience with the specified test methods and equipment. Testing shall be coordinated with owner's materials testing laboratory and in their presence when cores are extracted or when required by the Project Engineer. The owner reserves the right to extract treated cores 2 years after rejuvenator application. Viscosity values shall be determined using AASHTO T315-05 and compared to the original untreated values.

Street Sweeping: The Contractor shall be responsible for sweeping and cleaning of the streets prior to and after treatment. Prior to treatment, the street will be cleaned of all standing water, dirt, leaves, foreign materials, etc. This work shall be accomplished by hand brooming, power blowing or other methods approved by the Resident Engineer. If hand cleaning is not sufficient, then a self-propelled street sweeper shall be used. All sand used during the treatment must be removed no later than forty-eight (48) hours after treatment of

the street. This shall be accomplished by a combination of hand and mechanical sweeping. All turnouts, cul-de-sacs, etc. must be cleaned and free of any material that would interfere with the treatment. All debris generated by sweeping shall be picked up and disposed of by the contractor. Street sweeping shall be included in the price bid per square yard for asphalt rejuvenating agent. If after sand is swept and it is determined that a hazardous condition exists on the roadway, the Contractor must apply additional sand and sweep no later than twenty-four (24) hours following reapplication. No additional compensation will be allowed for reapplications and removal of sand.

Traffic Control and Safety: The Contractor shall schedule his operations and carry out the work in a manner to cause the least disturbance and/or interference with the normal flow of traffic over the areas to be treated. Treated portions of the pavement surfaces shall be kept closed and free from traffic until penetration has become complete and the area is suitable for traffic. Cure time shall be no longer than 90 minutes. When traffic must be maintained at all times on a particular street, then the Contractor shall apply asphalt rejuvenating agent to one (1) lane at a time. Traffic shall be maintained in the untreated lane until the traffic may be switched to the completed lane. Access to adjacent properties shall be maintained during the application. The Contractor shall be responsible for all traffic control and signing required to permit safe travel. All signing and barricading of the work zone shall comply with MUTCD guidelines and State standards. The Contractor shall notify the Resident Engineer as to the streets that are to be treated each day. All support vehicles used shall also have flashing beacons that can be seen from all sides of the vehicle, for safety considerations for all work on major arterials. If the Contractor fails to provide the required signing, the Contractor shall stop all operations until safe signing and barricading is achieved.

Spreading/Ordering of Sand or Screenings: The Contractor will furnish and apply sand or lime screenings. The contractor shall furnish all equipment, tools, labor and incidentals necessary to perform the sanding operation in accordance with this contract. Spreading shall consist of applying free flowing sharp sand, FA2 or limestone screenings to insure even distribution of the sand or screenings to be worked into any voids in the payment surface as directed by customer representative. The aggregate distributor shall apply sand or screenings at a rate of 1-4 pounds per square yard.

Aggregate distributor must be able to carry enough aggregate to cover an applied load of the rejuvenating agent, at least (9) nine tons. Repeated sanding may be required on some areas of pavement and contractor must be available on an as needed basis to provide the required sanding.

Resident Notification: The Contractor shall distribute by hand, a typed notice to all residences and businesses on the street to be treated. The notice will be delivered no more than 24 hours prior to the treatment of the road or as required by each individual agency. The notice will have a local phone number that residents may call to ask questions. The contractor shall also place the notice on the windshield of any parked cars on the street.

4.0 Method of Measurement:

Final measurement of the completed surface will not be made except for authorized changes during construction, or where appreciable errors are found in the contract quantity. Where required, measurement of maltene based asphalt rejuvenator, complete in place, will be made to the nearest square yard. The revision or correction will be computed and added to or deducted from the contract quantity.

5.0 Basis of Payment:

Payment for Maltene Based Asphalt Rejuvenator shall be full compensation for furnishing all required labor and materials to complete the Work per these specifications and will be paid for at the contract unit price per square yard.

**REQUIRED CONTRACT PROVISIONS
FEDERAL-AID CONSTRUCTION CONTRACTS**

- I. General
- II. Nondiscrimination
- III. Non-segregated Facilities
- IV. Davis-Bacon and Related Act Provisions
- V. Contract Work Hours and Safety Standards Act Provisions
- VI. Subletting or Assigning the Contract
- VII. Safety: Accident Prevention
- VIII. False Statements Concerning Highway Projects
- IX. Implementation of Clean Air Act and Federal Water Pollution Control Act
- X. Certification Regarding Debarment, Suspension, Ineligibility and Voluntary Exclusion
- XI. Certification Regarding Use of Contract Funds for Lobbying
- XII. Use of United States-Flag Vessels:

ATTACHMENTS

A. Employment and Materials Preference for Appalachian Development Highway System or Appalachian Local Access Road Contracts (included in Appalachian contracts only)

I. GENERAL

1. Form FHWA-1273 must be physically incorporated in each construction contract funded under title 23, United States Code, as required in 23 CFR 633.102(b) (excluding emergency contracts solely intended for debris removal). The contractor (or subcontractor) must insert this form in each subcontract and further require its inclusion in all lower tier subcontracts (excluding purchase orders, rental agreements and other agreements for supplies or services). 23 CFR 633.102(e).

The applicable requirements of Form FHWA-1273 are incorporated by reference for work done under any purchase order, rental agreement or agreement for other services. The prime contractor shall be responsible for compliance by any subcontractor, lower-tier subcontractor or service provider. 23 CFR 633.102(e).

Form FHWA-1273 must be included in all Federal-aid design-build contracts, in all subcontracts and in lower tier subcontracts (excluding subcontracts for design services, purchase orders, rental agreements and other agreements for supplies or services) in accordance with 23 CFR 633.102. The design-builder shall be responsible for compliance by any subcontractor, lower-tier subcontractor or service provider.

Contracting agencies may reference Form FHWA-1273 in solicitation-for-bids or request-for-proposals documents, however, the Form FHWA-1273 must be physically incorporated (not referenced) in all contracts, subcontracts and lower-tier subcontracts (excluding purchase orders, rental agreements and other agreements for supplies or services related to a construction contract). 23 CFR 633.102(b).

2. Subject to the applicability criteria noted in the following sections, these contract provisions shall apply to all work

performed on the contract by the contractor's own organization and with the assistance of workers under the contractor's immediate superintendence and to all work performed on the contract by piecework, station work, or by subcontract. 23 CFR 633.102(d).

3. A breach of any of the stipulations contained in these Required Contract Provisions may be sufficient grounds for withholding of progress payments, withholding of final payment, termination of the contract, suspension / debarment or any other action determined to be appropriate by the contracting agency and FHWA.

4. Selection of Labor: During the performance of this contract, the contractor shall not use convict labor for any purpose within the limits of a construction project on a Federal-aid highway unless it is labor performed by convicts who are on parole, supervised release, or probation. 23 U.S.C. 114(b). The term Federal-aid highway does not include roadways functionally classified as local roads or rural minor collectors. 23 U.S.C. 101(a).

II. NONDISCRIMINATION (23 CFR 230.107(a); 23 CFR Part 230, Subpart A, Appendix A; EO 11246)

The provisions of this section related to 23 CFR Part 230, Subpart A, Appendix A are applicable to all Federal-aid construction contracts and to all related construction subcontracts of \$10,000 or more. The provisions of 23 CFR Part 230 are not applicable to material supply, engineering, or architectural service contracts.

In addition, the contractor and all subcontractors must comply with the following policies: Executive Order 11246, 41 CFR Part 60, 29 CFR Parts 1625-1627, 23 U.S.C. 140, Section 504 of the Rehabilitation Act of 1973, as amended (29 U.S.C. 794), Title VI of the Civil Rights Act of 1964, as amended (42 U.S.C. 2000d et seq.), and related regulations including 49 CFR Parts 21, 26, and 27; and 23 CFR Parts 200, 230, and 633.

The contractor and all subcontractors must comply with: the requirements of the Equal Opportunity Clause in 41 CFR 60-1.4(b) and, for all construction contracts exceeding \$10,000, the Standard Federal Equal Employment Opportunity Construction Contract Specifications in 41 CFR 60-4.3.

Note: The U.S. Department of Labor has exclusive authority to determine compliance with Executive Order 11246 and the policies of the Secretary of Labor including 41 CFR Part 60, and 29 CFR Parts 1625-1627. The contracting agency and the FHWA have the authority and the responsibility to ensure compliance with 23 U.S.C. 140, Section 504 of the Rehabilitation Act of 1973, as amended (29 U.S.C. 794), and Title VI of the Civil Rights Act of 1964, as amended (42 U.S.C. 2000d et seq.), and related regulations including 49 CFR Parts 21, 26, and 27; and 23 CFR Parts 200, 230, and 633.

The following provision is adopted from 23 CFR Part 230, Subpart A, Appendix A, with appropriate revisions to conform to the U.S. Department of Labor (US DOL) and FHWA requirements.

1. Equal Employment Opportunity: Equal Employment Opportunity (EEO) requirements not to discriminate and to take affirmative action to assure equal opportunity as set forth under laws, executive orders, rules, regulations (see 28 CFR Part 35, 29 CFR Part 1630, 29 CFR Parts 1625-1627, 41 CFR Part 60 and 49 CFR Part 27) and orders of the Secretary of Labor as modified by the provisions prescribed herein, and imposed pursuant to 23 U.S.C. 140, shall constitute the EEO and specific affirmative action standards for the contractor's project activities under this contract. The provisions of the Americans with Disabilities Act of 1990 (42 U.S.C. 12101 et seq.) set forth under 28 CFR Part 35 and 29 CFR Part 1630 are incorporated by reference in this contract. In the execution of this contract, the contractor agrees to comply with the following minimum specific requirement activities of EEO:

a. The contractor will work with the contracting agency and the Federal Government to ensure that it has made every good faith effort to provide equal opportunity with respect to all of its terms and conditions of employment and in their review of activities under the contract. 23 CFR 230.409 (g)(4) & (5).

b. The contractor will accept as its operating policy the following statement:

"It is the policy of this Company to assure that applicants are employed, and that employees are treated during employment, without regard to their race, religion, sex, sexual orientation, gender identity, color, national origin, age or disability. Such action shall include: employment, upgrading, demotion, or transfer; recruitment or recruitment advertising; layoff or termination; rates of pay or other forms of compensation; and selection for training, including apprenticeship, pre-apprenticeship, and/or on-the-job training."

2. EEO Officer: The contractor will designate and make known to the contracting officers an EEO Officer who will have the responsibility for and must be capable of effectively administering and promoting an active EEO program and who must be assigned adequate authority and responsibility to do so.

3. Dissemination of Policy: All members of the contractor's staff who are authorized to hire, supervise, promote, and discharge employees, or who recommend such action or are substantially involved in such action, will be made fully cognizant of and will implement the contractor's EEO policy and contractual responsibilities to provide EEO in each grade and classification of employment. To ensure that the above agreement will be met, the following actions will be taken as a minimum:

a. Periodic meetings of supervisory and personnel office employees will be conducted before the start of work and then not less often than once every six months, at which time the contractor's EEO policy and its implementation will be reviewed and explained. The meetings will be conducted by the EEO Officer or other knowledgeable company official.

b. All new supervisory or personnel office employees will be given a thorough indoctrination by the EEO Officer, covering all major aspects of the contractor's EEO obligations within thirty days following their reporting for duty with the contractor.

c. All personnel who are engaged in direct recruitment for the project will be instructed by the EEO Officer in the contractor's procedures for locating and hiring minorities and women.

d. Notices and posters setting forth the contractor's EEO policy will be placed in areas readily accessible to employees, applicants for employment and potential employees.

e. The contractor's EEO policy and the procedures to implement such policy will be brought to the attention of employees by means of meetings, employee handbooks, or other appropriate means.

4. Recruitment: When advertising for employees, the contractor will include in all advertisements for employees the notation: "An Equal Opportunity Employer." All such advertisements will be placed in publications having a large circulation among minorities and women in the area from which the project work force would normally be derived.

a. The contractor will, unless precluded by a valid bargaining agreement, conduct systematic and direct recruitment through public and private employee referral sources likely to yield qualified minorities and women. To meet this requirement, the contractor will identify sources of potential minority group employees and establish with such identified sources procedures whereby minority and women applicants may be referred to the contractor for employment consideration.

b. In the event the contractor has a valid bargaining agreement providing for exclusive hiring hall referrals, the contractor is expected to observe the provisions of that agreement to the extent that the system meets the contractor's compliance with EEO contract provisions. Where implementation of such an agreement has the effect of discriminating against minorities or women, or obligates the contractor to do the same, such implementation violates Federal nondiscrimination provisions.

c. The contractor will encourage its present employees to refer minorities and women as applicants for employment. Information and procedures with regard to referring such applicants will be discussed with employees.

5. Personnel Actions: Wages, working conditions, and employee benefits shall be established and administered, and personnel actions of every type, including hiring, upgrading, promotion, transfer, demotion, layoff, and termination, shall be taken without regard to race, color, religion, sex, sexual orientation, gender identity, national origin, age or disability. The following procedures shall be followed:

a. The contractor will conduct periodic inspections of project sites to ensure that working conditions and employee facilities do not indicate discriminatory treatment of project site personnel.

b. The contractor will periodically evaluate the spread of wages paid within each classification to determine any evidence of discriminatory wage practices.

c. The contractor will periodically review selected personnel actions in depth to determine whether there is evidence of discrimination. Where evidence is found, the contractor will promptly take corrective action. If the review indicates that the discrimination may extend beyond the actions reviewed, such corrective action shall include all affected persons.

d. The contractor will promptly investigate all complaints of alleged discrimination made to the contractor in connection with its obligations under this contract, will attempt to resolve such complaints, and will take appropriate corrective action

within a reasonable time. If the investigation indicates that the discrimination may affect persons other than the complainant, such corrective action shall include such other persons. Upon completion of each investigation, the contractor will inform every complainant of all of their avenues of appeal.

6. Training and Promotion:

a. The contractor will assist in locating, qualifying, and increasing the skills of minorities and women who are applicants for employment or current employees. Such efforts should be aimed at developing full journey level status employees in the type of trade or job classification involved.

b. Consistent with the contractor's work force requirements and as permissible under Federal and State regulations, the contractor shall make full use of training programs (i.e., apprenticeship and on-the-job training programs for the geographical area of contract performance). In the event a special provision for training is provided under this contract, this subparagraph will be superseded as indicated in the special provision. The contracting agency may reserve training positions for persons who receive welfare assistance in accordance with 23 U.S.C. 140(a).

c. The contractor will advise employees and applicants for employment of available training programs and entrance requirements for each.

d. The contractor will periodically review the training and promotion potential of employees who are minorities and women and will encourage eligible employees to apply for such training and promotion.

7. Unions: If the contractor relies in whole or in part upon unions as a source of employees, the contractor will use good faith efforts to obtain the cooperation of such unions to increase opportunities for minorities and women. 23 CFR 230.409. Actions by the contractor, either directly or through a contractor's association acting as agent, will include the procedures set forth below:

a. The contractor will use good faith efforts to develop, in cooperation with the unions, joint training programs aimed toward qualifying more minorities and women for membership in the unions and increasing the skills of minorities and women so that they may qualify for higher paying employment.

b. The contractor will use good faith efforts to incorporate an EEO clause into each union agreement to the end that such union will be contractually bound to refer applicants without regard to their race, color, religion, sex, sexual orientation, gender identity, national origin, age, or disability.

c. The contractor is to obtain information as to the referral practices and policies of the labor union except that to the extent such information is within the exclusive possession of the labor union and such labor union refuses to furnish such information to the contractor, the contractor shall so certify to the contracting agency and shall set forth what efforts have been made to obtain such information.

d. In the event the union is unable to provide the contractor with a reasonable flow of referrals within the time limit set forth in the collective bargaining agreement, the contractor will, through independent recruitment efforts, fill the employment vacancies without regard to race, color, religion, sex, sexual orientation, gender identity, national origin, age, or disability; making full efforts to obtain qualified and/or qualifiable minorities and women. The failure of a union to provide

sufficient referrals (even though it is obligated to provide exclusive referrals under the terms of a collective bargaining agreement) does not relieve the contractor from the requirements of this paragraph. In the event the union referral practice prevents the contractor from meeting the obligations pursuant to Executive Order 11246, as amended, and these special provisions, such contractor shall immediately notify the contracting agency.

8. Reasonable Accommodation for Applicants / Employees with Disabilities: The contractor must be familiar with the requirements for and comply with the Americans with Disabilities Act and all rules and regulations established thereunder. Employers must provide reasonable accommodation in all employment activities unless to do so would cause an undue hardship.

9. Selection of Subcontractors, Procurement of Materials and Leasing of Equipment: The contractor shall not discriminate on the grounds of race, color, religion, sex, sexual orientation, gender identity, national origin, age, or disability in the selection and retention of subcontractors, including procurement of materials and leases of equipment. The contractor shall take all necessary and reasonable steps to ensure nondiscrimination in the administration of this contract.

a. The contractor shall notify all potential subcontractors, suppliers, and lessors of their EEO obligations under this contract.

b. The contractor will use good faith efforts to ensure subcontractor compliance with their EEO obligations.

10. Assurances Required:

a. The requirements of 49 CFR Part 26 and the State DOT's FHWA-approved Disadvantaged Business Enterprise (DBE) program are incorporated by reference.

b. The contractor, subrecipient or subcontractor shall not discriminate on the basis of race, color, national origin, or sex in the performance of this contract. The contractor shall carry out applicable requirements of 49 CFR part 26 in the award and administration of DOT-assisted contracts. Failure by the contractor to carry out these requirements is a material breach of this contract, which may result in the termination of this contract or such other remedy as the recipient deems appropriate, which may include, but is not limited to:

- (1) Withholding monthly progress payments;
- (2) Assessing sanctions;
- (3) Liquidated damages; and/or
- (4) Disqualifying the contractor from future bidding as non-responsible.

c. The Title VI and nondiscrimination provisions of U.S. DOT Order 1050.2A at Appendixes A and E are incorporated by reference. 49 CFR Part 21.

11. Records and Reports: The contractor shall keep such records as necessary to document compliance with the EEO requirements. Such records shall be retained for a period of three years following the date of the final payment to the contractor for all contract work and shall be available at reasonable times and places for inspection by authorized representatives of the contracting agency and the FHWA.

a. The records kept by the contractor shall document the following:

(1) The number and work hours of minority and non-minority group members and women employed in each work classification on the project;

(2) The progress and efforts being made in cooperation with unions, when applicable, to increase employment opportunities for minorities and women; and

(3) The progress and efforts being made in locating, hiring, training, qualifying, and upgrading minorities and women.

b. The contractors and subcontractors will submit an annual report to the contracting agency each July for the duration of the project indicating the number of minority, women, and non-minority group employees currently engaged in each work classification required by the contract work. This information is to be reported on [Form FHWA-1391](#). The staffing data should represent the project work force on board in all or any part of the last payroll period preceding the end of July. If on-the-job training is being required by special provision, the contractor will be required to collect and report training data. The employment data should reflect the work force on board during all or any part of the last payroll period preceding the end of July.

III. NONSEGREGATED FACILITIES

This provision is applicable to all Federal-aid construction contracts and to all related construction subcontracts of more than \$10,000. 41 CFR 60-1.5.

As prescribed by 41 CFR 60-1.8, the contractor must ensure that facilities provided for employees are provided in such a manner that segregation on the basis of race, color, religion, sex, sexual orientation, gender identity, or national origin cannot result. The contractor may neither require such segregated use by written or oral policies nor tolerate such use by employee custom. The contractor's obligation extends further to ensure that its employees are not assigned to perform their services at any location under the contractor's control where the facilities are segregated. The term "facilities" includes waiting rooms, work areas, restaurants and other eating areas, time clocks, restrooms, washrooms, locker rooms and other storage or dressing areas, parking lots, drinking fountains, recreation or entertainment areas, transportation, and housing provided for employees. The contractor shall provide separate or single-user restrooms and necessary dressing or sleeping areas to assure privacy between sexes.

IV. DAVIS-BACON AND RELATED ACT PROVISIONS

This section is applicable to all Federal-aid construction projects exceeding \$2,000 and to all related subcontracts and lower-tier subcontracts (regardless of subcontract size), in accordance with 29 CFR 5.5. The requirements apply to all projects located within the right-of-way of a roadway that is functionally classified as Federal-aid highway. 23 U.S.C. 113. This excludes roadways functionally classified as local roads or rural minor collectors, which are exempt. 23 U.S.C. 101. Where applicable law requires that projects be treated as a project on a Federal-aid highway, the provisions of this subpart will apply regardless of the location of the project. Examples include: Surface Transportation Block Grant Program projects funded under 23 U.S.C. 133 [excluding recreational trails projects], the Nationally Significant Freight and Highway

Projects funded under 23 U.S.C. 117, and National Highway Freight Program projects funded under 23 U.S.C. 167.

The following provisions are from the U.S. Department of Labor regulations in 29 CFR 5.5 "Contract provisions and related matters" with minor revisions to conform to the FHWA-1273 format and FHWA program requirements.

1. Minimum wages (29 CFR 5.5)

a. All laborers and mechanics employed or working upon the site of the work, will be paid unconditionally and not less often than once a week, and without subsequent deduction or rebate on any account (except such payroll deductions as are permitted by regulations issued by the Secretary of Labor under the Copeland Act (29 CFR part 3)), the full amount of wages and bona fide fringe benefits (or cash equivalents thereof) due at time of payment computed at rates not less than those contained in the wage determination of the Secretary of Labor which is attached hereto and made a part hereof, regardless of any contractual relationship which may be alleged to exist between the contractor and such laborers and mechanics.

Contributions made or costs reasonably anticipated for bona fide fringe benefits under section 1(b)(2) of the Davis-Bacon Act on behalf of laborers or mechanics are considered wages paid to such laborers or mechanics, subject to the provisions of paragraph 1.d. of this section; also, regular contributions made or costs incurred for more than a weekly period (but not less often than quarterly) under plans, funds, or programs which cover the particular weekly period, are deemed to be constructively made or incurred during such weekly period. Such laborers and mechanics shall be paid the appropriate wage rate and fringe benefits on the wage determination for the classification of work actually performed, without regard to skill, except as provided in 29 CFR 5.5(a)(4). Laborers or mechanics performing work in more than one classification may be compensated at the rate specified for each classification for the time actually worked therein: Provided, That the employer's payroll records accurately set forth the time spent in each classification in which work is performed. The wage determination (including any additional classification and wage rates conformed under paragraph 1.b. of this section) and the Davis-Bacon poster (WH-1321) shall be posted at all times by the contractor and its subcontractors at the site of the work in a prominent and accessible place where it can be easily seen by the workers.

b.(1) The contracting officer shall require that any class of laborers or mechanics, including helpers, which is not listed in the wage determination and which is to be employed under the contract shall be classified in conformance with the wage determination. The contracting officer shall approve an additional classification and wage rate and fringe benefits therefore only when the following criteria have been met:

(i) The work to be performed by the classification requested is not performed by a classification in the wage determination; and

(ii) The classification is utilized in the area by the construction industry; and

(iii) The proposed wage rate, including any bona fide fringe benefits, bears a reasonable relationship to the wage rates contained in the wage determination.

(2) If the contractor and the laborers and mechanics to be employed in the classification (if known), or their representatives, and the contracting officer agree on the classification and wage rate (including the amount designated for fringe benefits where appropriate), a report of the action taken shall be sent by the contracting officer to the Administrator of the Wage and Hour Division, U.S. Department of Labor, Washington, DC 20210. The Administrator, or an authorized representative, will approve, modify, or disapprove every additional classification action within 30 days of receipt and so advise the contracting officer or will notify the contracting officer within the 30-day period that additional time is necessary.

(3) In the event the contractor, the laborers or mechanics to be employed in the classification or their representatives, and the contracting officer do not agree on the proposed classification and wage rate (including the amount designated for fringe benefits, where appropriate), the contracting officer shall refer the questions, including the views of all interested parties and the recommendation of the contracting officer, to the Administrator for determination. The Administrator, or an authorized representative, will issue a determination within 30 days of receipt and so advise the contracting officer or will notify the contracting officer within the 30-day period that additional time is necessary.

(4) The wage rate (including fringe benefits where appropriate) determined pursuant to paragraphs 1.b.(2) or 1.b.(3) of this section, shall be paid to all workers performing work in the classification under this contract from the first day on which work is performed in the classification.

c. Whenever the minimum wage rate prescribed in the contract for a class of laborers or mechanics includes a fringe benefit which is not expressed as an hourly rate, the contractor shall either pay the benefit as stated in the wage determination or shall pay another bona fide fringe benefit or an hourly cash equivalent thereof.

d. If the contractor does not make payments to a trustee or other third person, the contractor may consider as part of the wages of any laborer or mechanic the amount of any costs reasonably anticipated in providing bona fide fringe benefits under a plan or program, Provided, That the Secretary of Labor has found, upon the written request of the contractor, that the applicable standards of the Davis-Bacon Act have been met. The Secretary of Labor may require the contractor to set aside in a separate account assets for the meeting of obligations under the plan or program.

2. Withholding (29 CFR 5.5)

The contracting agency shall upon its own action or upon written request of an authorized representative of the Department of Labor, withhold or cause to be withheld from the contractor under this contract, or any other Federal contract with the same prime contractor, or any other federally-assisted contract subject to Davis-Bacon prevailing wage requirements, which is held by the same prime contractor, so much of the accrued payments or advances as may be considered necessary to pay laborers and mechanics,

including apprentices, trainees, and helpers, employed by the contractor or any subcontractor the full amount of wages required by the contract. In the event of failure to pay any laborer or mechanic, including any apprentice, trainee, or helper, employed or working on the site of the work, all or part of the wages required by the contract, the contracting agency may, after written notice to the contractor, take such action as may be necessary to cause the suspension of any further payment, advance, or guarantee of funds until such violations have ceased.

3. Payrolls and basic records (29 CFR 5.5)

a. Payrolls and basic records relating thereto shall be maintained by the contractor during the course of the work and preserved for a period of three years thereafter for all laborers and mechanics working at the site of the work. Such records shall contain the name, address, and social security number of each such worker, his or her correct classification, hourly rates of wages paid (including rates of contributions or costs anticipated for bona fide fringe benefits or cash equivalents thereof of the types described in section 1(b)(2)(B) of the Davis-Bacon Act), daily and weekly number of hours worked, deductions made and actual wages paid. Whenever the Secretary of Labor has found under 29 CFR 5.5(a)(1)(iv) that the wages of any laborer or mechanic include the amount of any costs reasonably anticipated in providing benefits under a plan or program described in section 1(b)(2)(B) of the Davis-Bacon Act, the contractor shall maintain records which show that the commitment to provide such benefits is enforceable, that the plan or program is financially responsible, and that the plan or program has been communicated in writing to the laborers or mechanics affected, and records which show the costs anticipated or the actual cost incurred in providing such benefits. Contractors employing apprentices or trainees under approved programs shall maintain written evidence of the registration of apprenticeship programs and certification of trainee programs, the registration of the apprentices and trainees, and the ratios and wage rates prescribed in the applicable programs.

b.(1) The contractor shall submit weekly for each week in which any contract work is performed a copy of all payrolls to the contracting agency. The payrolls submitted shall set out accurately and completely all of the information required to be maintained under 29 CFR 5.5(a)(3)(i), except that full social security numbers and home addresses shall not be included on weekly transmittals. Instead the payrolls shall only need to include an individually identifying number for each employee (e.g., the last four digits of the employee's social security number). The required weekly payroll information may be submitted in any form desired. Optional Form WH-347 is available for this purpose from the Wage and Hour Division Web site. The prime contractor is responsible for the submission of copies of payrolls by all subcontractors. Contractors and subcontractors shall maintain the full social security number and current address of each covered worker, and shall provide them upon request to the contracting agency for transmission to the State DOT, the FHWA or the Wage and Hour Division of the Department of Labor for purposes of an investigation or audit of compliance with prevailing wage requirements. It is not a violation of this section for a prime contractor to require a subcontractor to provide addresses and social security numbers to the prime contractor for its own records, without weekly submission to the contracting agency.

(2) Each payroll submitted shall be accompanied by a "Statement of Compliance," signed by the contractor or

subcontractor or his or her agent who pays or supervises the payment of the persons employed under the contract and shall certify the following:

(i) That the payroll for the payroll period contains the information required to be provided under 29 CFR 5.5(a)(3)(ii), the appropriate information is being maintained under 29 CFR 5.5(a)(3)(i), and that such information is correct and complete;

(ii) That each laborer or mechanic (including each helper, apprentice, and trainee) employed on the contract during the payroll period has been paid the full weekly wages earned, without rebate, either directly or indirectly, and that no deductions have been made either directly or indirectly from the full wages earned, other than permissible deductions as set forth in 29 CFR part 3;

(iii) That each laborer or mechanic has been paid not less than the applicable wage rates and fringe benefits or cash equivalents for the classification of work performed, as specified in the applicable wage determination incorporated into the contract.

(3) The weekly submission of a properly executed certification set forth on the reverse side of Optional Form WH-347 shall satisfy the requirement for submission of the "Statement of Compliance" required by paragraph 3.b.(2) of this section.

(4) The falsification of any of the above certifications may subject the contractor or subcontractor to civil or criminal prosecution under 18 U.S.C. 1001 and 31 U.S.C. 231.

c. The contractor or subcontractor shall make the records required under paragraph 3.a. of this section available for inspection, copying, or transcription by authorized representatives of the contracting agency, the State DOT, the FHWA, or the Department of Labor, and shall permit such representatives to interview employees during working hours on the job. If the contractor or subcontractor fails to submit the required records or to make them available, the FHWA may, after written notice to the contractor, the contracting agency or the State DOT, take such action as may be necessary to cause the suspension of any further payment, advance, or guarantee of funds. Furthermore, failure to submit the required records upon request or to make such records available may be grounds for debarment action pursuant to 29 CFR 5.12.

4. Apprentices and trainees (29 CFR 5.5)

a. Apprentices (programs of the USDOL).

Apprentices will be permitted to work at less than the predetermined rate for the work they performed when they are employed pursuant to and individually registered in a bona fide apprenticeship program registered with the U.S. Department of Labor, Employment and Training Administration, Office of Apprenticeship Training, Employer and Labor Services, or with a State Apprenticeship Agency recognized by the Office, or if a person is employed in his or her first 90 days of probationary employment as an apprentice in such an apprenticeship program, who is not individually registered in the program, but who has been certified by the Office of Apprenticeship Training, Employer and Labor Services or a State

Apprenticeship Agency (where appropriate) to be eligible for probationary employment as an apprentice.

The allowable ratio of apprentices to journeymen on the job site in any craft classification shall not be greater than the ratio permitted to the contractor as to the entire work force under the registered program. Any worker listed on a payroll at an apprentice wage rate, who is not registered or otherwise employed as stated above, shall be paid not less than the applicable wage rate on the wage determination for the classification of work actually performed. In addition, any apprentice performing work on the job site in excess of the ratio permitted under the registered program shall be paid not less than the applicable wage rate on the wage determination for the work actually performed. Where a contractor is performing construction on a project in a locality other than that in which its program is registered, the ratios and wage rates (expressed in percentages of the journeyman's hourly rate) specified in the contractor's or subcontractor's registered program shall be observed.

Every apprentice must be paid at not less than the rate specified in the registered program for the apprentice's level of progress, expressed as a percentage of the journeymen hourly rate specified in the applicable wage determination. Apprentices shall be paid fringe benefits in accordance with the provisions of the apprenticeship program. If the apprenticeship program does not specify fringe benefits, apprentices must be paid the full amount of fringe benefits listed on the wage determination for the applicable classification. If the Administrator determines that a different practice prevails for the applicable apprentice classification, fringes shall be paid in accordance with that determination.

In the event the Office of Apprenticeship Training, Employer and Labor Services, or a State Apprenticeship Agency recognized by the Office, withdraws approval of an apprenticeship program, the contractor will no longer be permitted to utilize apprentices at less than the applicable predetermined rate for the work performed until an acceptable program is approved.

b. Trainees (programs of the USDOL).

Except as provided in 29 CFR 5.16, trainees will not be permitted to work at less than the predetermined rate for the work performed unless they are employed pursuant to and individually registered in a program which has received prior approval, evidenced by formal certification by the U.S. Department of Labor, Employment and Training Administration.

The ratio of trainees to journeymen on the job site shall not be greater than permitted under the plan approved by the Employment and Training Administration.

Every trainee must be paid at not less than the rate specified in the approved program for the trainee's level of progress, expressed as a percentage of the journeyman hourly rate specified in the applicable wage determination. Trainees shall be paid fringe benefits in accordance with the provisions of the trainee program. If the trainee program does not mention fringe benefits, trainees shall be paid the full amount of fringe benefits listed on the wage determination unless the Administrator of the Wage and Hour Division determines that there is an apprenticeship program associated with the

corresponding journeyman wage rate on the wage determination which provides for less than full fringe benefits for apprentices. Any employee listed on the payroll at a trainee rate who is not registered and participating in a training plan approved by the Employment and Training Administration shall be paid not less than the applicable wage rate on the wage determination for the classification of work actually performed. In addition, any trainee performing work on the job site in excess of the ratio permitted under the registered program shall be paid not less than the applicable wage rate on the wage determination for the work actually performed.

In the event the Employment and Training Administration withdraws approval of a training program, the contractor will no longer be permitted to utilize trainees at less than the applicable predetermined rate for the work performed until an acceptable program is approved.

c. Equal employment opportunity. The utilization of apprentices, trainees and journeymen under this part shall be in conformity with the equal employment opportunity requirements of Executive Order 11246, as amended, and 29 CFR part 30.

d. Apprentices and Trainees (programs of the U.S. DOT).

Apprentices and trainees working under apprenticeship and skill training programs which have been certified by the Secretary of Transportation as promoting EEO in connection with Federal-aid highway construction programs are not subject to the requirements of paragraph 4 of this Section IV. 23 CFR 230.111(e)(2). The straight time hourly wage rates for apprentices and trainees under such programs will be established by the particular programs. The ratio of apprentices and trainees to journeymen shall not be greater than permitted by the terms of the particular program.

5. Compliance with Copeland Act requirements. The contractor shall comply with the requirements of 29 CFR part 3, which are incorporated by reference in this contract as provided in 29 CFR 5.5.

6. Subcontracts. The contractor or subcontractor shall insert Form FHWA-1273 in any subcontracts and also require the subcontractors to include Form FHWA-1273 in any lower tier subcontracts. The prime contractor shall be responsible for the compliance by any subcontractor or lower tier subcontractor with all the contract clauses in 29 CFR 5.5.

7. Contract termination: debarment. A breach of the contract clauses in 29 CFR 5.5 may be grounds for termination of the contract, and for debarment as a contractor and a subcontractor as provided in 29 CFR 5.12.

8. Compliance with Davis-Bacon and Related Act requirements. All rulings and interpretations of the Davis-Bacon and Related Acts contained in 29 CFR parts 1, 3, and 5 are herein incorporated by reference in this contract as provided in 29 CFR 5.5.

9. Disputes concerning labor standards. As provided in 29 CFR 5.5, disputes arising out of the labor standards provisions of this contract shall not be subject to the general disputes clause of this contract. Such disputes shall be resolved in accordance with the procedures of the Department of Labor

set forth in 29 CFR parts 5, 6, and 7. Disputes within the meaning of this clause include disputes between the contractor (or any of its subcontractors) and the contracting agency, the U.S. Department of Labor, or the employees or their representatives.

10. Certification of eligibility (29 CFR 5.5)

a. By entering into this contract, the contractor certifies that neither it (nor he or she) nor any person or firm who has an interest in the contractor's firm is a person or firm ineligible to be awarded Government contracts by virtue of section 3(a) of the Davis-Bacon Act or 29 CFR 5.12(a)(1).

b. No part of this contract shall be subcontracted to any person or firm ineligible for award of a Government contract by virtue of section 3(a) of the Davis-Bacon Act or 29 CFR 5.12(a)(1).

c. The penalty for making false statements is prescribed in the U.S. Criminal Code, 18 U.S.C. 1001.

V. CONTRACT WORK HOURS AND SAFETY STANDARDS ACT

Pursuant to 29 CFR 5.5(b), the following clauses apply to any Federal-aid construction contract in an amount in excess of \$100,000 and subject to the overtime provisions of the Contract Work Hours and Safety Standards Act. These clauses shall be inserted in addition to the clauses required by 29 CFR 5.5(a) or 29 CFR 4.6. As used in this paragraph, the terms laborers and mechanics include watchmen and guards.

1. Overtime requirements. No contractor or subcontractor contracting for any part of the contract work which may require or involve the employment of laborers or mechanics shall require or permit any such laborer or mechanic in any workweek in which he or she is employed on such work to work in excess of forty hours in such workweek unless such laborer or mechanic receives compensation at a rate not less than one and one-half times the basic rate of pay for all hours worked in excess of forty hours in such workweek. 29 CFR 5.5.

2. Violation; liability for unpaid wages; liquidated damages. In the event of any violation of the clause set forth in paragraph 1 of this section, the contractor and any subcontractor responsible therefor shall be liable for the unpaid wages. In addition, such contractor and subcontractor shall be liable to the United States (in the case of work done under contract for the District of Columbia or a territory, to such District or to such territory), for liquidated damages. Such liquidated damages shall be computed with respect to each individual laborer or mechanic, including watchmen and guards, employed in violation of the clause set forth in paragraph 1 of this section, in the sum currently provided in 29 CFR 5.5(b)(2)* for each calendar day on which such individual was required or permitted to work in excess of the standard workweek of forty hours without payment of the overtime wages required by the clause set forth in paragraph 1 of this section. 29 CFR 5.5.

* \$27 as of January 23, 2019 (See 84 FR 213-01, 218) as may be adjusted annually by the Department of Labor; pursuant to the Federal Civil Penalties Inflation Adjustment Act of 1990).

3. Withholding for unpaid wages and liquidated damages.

The FHWA or the contracting agency shall upon its own action or upon written request of an authorized representative of the Department of Labor withhold or cause to be withheld, from any moneys payable on account of work performed by the contractor or subcontractor under any such contract or any other Federal contract with the same prime contractor, or any other federally-assisted contract subject to the Contract Work Hours and Safety Standards Act, which is held by the same prime contractor, such sums as may be determined to be necessary to satisfy any liabilities of such contractor or subcontractor for unpaid wages and liquidated damages as provided in the clause set forth in paragraph 2 of this section. 29 CFR 5.5.

4. Subcontracts. The contractor or subcontractor shall insert in any subcontracts the clauses set forth in paragraphs 1 through 4 of this section and also a clause requiring the subcontractors to include these clauses in any lower tier subcontracts. The prime contractor shall be responsible for compliance by any subcontractor or lower tier subcontractor with the clauses set forth in paragraphs 1 through 4 of this section. 29 CFR 5.5.

VI. SUBLETTING OR ASSIGNING THE CONTRACT

This provision is applicable to all Federal-aid construction contracts on the National Highway System pursuant to 23 CFR 635.116.

1. The contractor shall perform with its own organization contract work amounting to not less than 30 percent (or a greater percentage if specified elsewhere in the contract) of the total original contract price, excluding any specialty items designated by the contracting agency. Specialty items may be performed by subcontract and the amount of any such specialty items performed may be deducted from the total original contract price before computing the amount of work required to be performed by the contractor's own organization (23 CFR 635.116).

a. The term "perform work with its own organization" in paragraph 1 of Section VI refers to workers employed or leased by the prime contractor, and equipment owned or rented by the prime contractor, with or without operators. Such term does not include employees or equipment of a subcontractor or lower tier subcontractor, agents of the prime contractor, or any other assignees. The term may include payments for the costs of hiring leased employees from an employee leasing firm meeting all relevant Federal and State regulatory requirements. Leased employees may only be included in this term if the prime contractor meets all of the following conditions: (based on longstanding interpretation)

- (1) the prime contractor maintains control over the supervision of the day-to-day activities of the leased employees;
- (2) the prime contractor remains responsible for the quality of the work of the leased employees;
- (3) the prime contractor retains all power to accept or exclude individual employees from work on the project; and
- (4) the prime contractor remains ultimately responsible for the payment of predetermined minimum wages, the submission of payrolls, statements of compliance and all other Federal regulatory requirements.

b. "Specialty Items" shall be construed to be limited to work that requires highly specialized knowledge, abilities, or

equipment not ordinarily available in the type of contracting organizations qualified and expected to bid or propose on the contract as a whole and in general are to be limited to minor components of the overall contract. 23 CFR 635.102.

2. Pursuant to 23 CFR 635.116(a), the contract amount upon which the requirements set forth in paragraph (1) of Section VI is computed includes the cost of material and manufactured products which are to be purchased or produced by the contractor under the contract provisions.

3. Pursuant to 23 CFR 635.116(c), the contractor shall furnish (a) a competent superintendent or supervisor who is employed by the firm, has full authority to direct performance of the work in accordance with the contract requirements, and is in charge of all construction operations (regardless of who performs the work) and (b) such other of its own organizational resources (supervision, management, and engineering services) as the contracting officer determines is necessary to assure the performance of the contract.

4. No portion of the contract shall be sublet, assigned or otherwise disposed of except with the written consent of the contracting officer, or authorized representative, and such consent when given shall not be construed to relieve the contractor of any responsibility for the fulfillment of the contract. Written consent will be given only after the contracting agency has assured that each subcontract is evidenced in writing and that it contains all pertinent provisions and requirements of the prime contract. (based on longstanding interpretation of 23 CFR 635.116).

5. The 30-percent self-performance requirement of paragraph (1) is not applicable to design-build contracts; however, contracting agencies may establish their own self-performance requirements. 23 CFR 635.116(d).

VII. SAFETY: ACCIDENT PREVENTION

This provision is applicable to all Federal-aid construction contracts and to all related subcontracts.

1. In the performance of this contract the contractor shall comply with all applicable Federal, State, and local laws governing safety, health, and sanitation (23 CFR Part 635). The contractor shall provide all safeguards, safety devices and protective equipment and take any other needed actions as it determines, or as the contracting officer may determine, to be reasonably necessary to protect the life and health of employees on the job and the safety of the public and to protect property in connection with the performance of the work covered by the contract. 23 CFR 635.108.

2. It is a condition of this contract, and shall be made a condition of each subcontract, which the contractor enters into pursuant to this contract, that the contractor and any subcontractor shall not permit any employee, in performance of the contract, to work in surroundings or under conditions which are unsanitary, hazardous or dangerous to his/her health or safety, as determined under construction safety and health standards (29 CFR Part 1926) promulgated by the Secretary of Labor, in accordance with Section 107 of the Contract Work Hours and Safety Standards Act (40 U.S.C. 3704). 29 CFR 1926.10.

3. Pursuant to 29 CFR 1926.3, it is a condition of this contract that the Secretary of Labor or authorized representative thereof, shall have right of entry to any site of contract performance to inspect or investigate the matter of compliance

with the construction safety and health standards and to carry out the duties of the Secretary under Section 107 of the Contract Work Hours and Safety Standards Act (40 U.S.C. 3704).

VIII. FALSE STATEMENTS CONCERNING HIGHWAY PROJECTS

This provision is applicable to all Federal-aid construction contracts and to all related subcontracts.

In order to assure high quality and durable construction in conformity with approved plans and specifications and a high degree of reliability on statements and representations made by engineers, contractors, suppliers, and workers on Federal-aid highway projects, it is essential that all persons concerned with the project perform their functions as carefully, thoroughly, and honestly as possible. Willful falsification, distortion, or misrepresentation with respect to any facts related to the project is a violation of Federal law. To prevent any misunderstanding regarding the seriousness of these and similar acts, Form FHWA-1022 shall be posted on each Federal-aid highway project (23 CFR Part 635) in one or more places where it is readily available to all persons concerned with the project:

18 U.S.C. 1020 reads as follows:

"Whoever, being an officer, agent, or employee of the United States, or of any State or Territory, or whoever, whether a person, association, firm, or corporation, knowingly makes any false statement, false representation, or false report as to the character, quality, quantity, or cost of the material used or to be used, or the quantity or quality of the work performed or to be performed, or the cost thereof in connection with the submission of plans, maps, specifications, contracts, or costs of construction on any highway or related project submitted for approval to the Secretary of Transportation; or

Whoever knowingly makes any false statement, false representation, false report or false claim with respect to the character, quality, quantity, or cost of any work performed or to be performed, or materials furnished or to be furnished, in connection with the construction of any highway or related project approved by the Secretary of Transportation; or

Whoever knowingly makes any false statement or false representation as to material fact in any statement, certificate, or report submitted pursuant to provisions of the Federal-aid Roads Act approved July 11, 1916, (39 Stat. 355), as amended and supplemented;

Shall be fined under this title or imprisoned not more than 5 years or both."

IX. IMPLEMENTATION OF CLEAN AIR ACT AND FEDERAL WATER POLLUTION CONTROL ACT (42 U.S.C. 7606; 2 CFR 200.88; EO 11738)

This provision is applicable to all Federal-aid construction contracts in excess of \$150,000 and to all related subcontracts. 48 CFR 2.101; 2 CFR 200.326.

By submission of this bid/proposal or the execution of this contract or subcontract, as appropriate, the bidder, proposer, Federal-aid construction contractor, subcontractor, supplier, or vendor agrees to comply with all applicable standards, orders

or regulations issued pursuant to the Clean Air Act (42 U.S.C. 7401-7671q) and the Federal Water Pollution Control Act, as amended (33 U.S.C. 1251-1387). Violations must be reported to the Federal Highway Administration and the Regional Office of the Environmental Protection Agency. 2 CFR Part 200, Appendix II.

The contractor agrees to include or cause to be included the requirements of this Section in every subcontract, and further agrees to take such action as the contracting agency may direct as a means of enforcing such requirements. 2 CFR 200.326.

X. CERTIFICATION REGARDING DEBARMENT, SUSPENSION, INELIGIBILITY AND VOLUNTARY EXCLUSION

This provision is applicable to all Federal-aid construction contracts, design-build contracts, subcontracts, lower-tier subcontracts, purchase orders, lease agreements, consultant contracts or any other covered transaction requiring FHWA approval or that is estimated to cost \$25,000 or more – as defined in 2 CFR Parts 180 and 1200. 2 CFR 180.220 and 1200.220.

1. Instructions for Certification – First Tier Participants:

a. By signing and submitting this proposal, the prospective first tier participant is providing the certification set out below.

b. The inability of a person to provide the certification set out below will not necessarily result in denial of participation in this covered transaction. The prospective first tier participant shall submit an explanation of why it cannot provide the certification set out below. The certification or explanation will be considered in connection with the department or agency's determination whether to enter into this transaction. However, failure of the prospective first tier participant to furnish a certification or an explanation shall disqualify such a person from participation in this transaction. 2 CFR 180.320.

c. The certification in this clause is a material representation of fact upon which reliance was placed when the contracting agency determined to enter into this transaction. If it is later determined that the prospective participant knowingly rendered an erroneous certification, in addition to other remedies available to the Federal Government, the contracting agency may terminate this transaction for cause of default. 2 CFR 180.325.

d. The prospective first tier participant shall provide immediate written notice to the contracting agency to whom this proposal is submitted if any time the prospective first tier participant learns that its certification was erroneous when submitted or has become erroneous by reason of changed circumstances. 2 CFR 180.345 and 180.350.

e. The terms "covered transaction," "debarred," "suspended," "ineligible," "participant," "person," "principal," and "voluntarily excluded," as used in this clause, are defined in 2 CFR Parts 180, Subpart I, 180.900-180.1020, and 1200. "First Tier Covered Transactions" refers to any covered transaction between a recipient or subrecipient of Federal funds and a participant (such as the prime or general contract). "Lower Tier Covered Transactions" refers to any covered transaction under a First Tier Covered Transaction (such as subcontracts). "First Tier Participant" refers to the participant

who has entered into a covered transaction with a recipient or subrecipient of Federal funds (such as the prime or general contractor). "Lower Tier Participant" refers any participant who has entered into a covered transaction with a First Tier Participant or other Lower Tier Participants (such as subcontractors and suppliers).

f. The prospective first tier participant agrees by submitting this proposal that, should the proposed covered transaction be entered into, it shall not knowingly enter into any lower tier covered transaction with a person who is debarred, suspended, declared ineligible, or voluntarily excluded from participation in this covered transaction, unless authorized by the department or agency entering into this transaction. 2 CFR 180.330.

g. The prospective first tier participant further agrees by submitting this proposal that it will include the clause titled "Certification Regarding Debarment, Suspension, Ineligibility and Voluntary Exclusion-Lower Tier Covered Transactions," provided by the department or contracting agency, entering into this covered transaction, without modification, in all lower tier covered transactions and in all solicitations for lower tier covered transactions exceeding the \$25,000 threshold. 2 CFR 180.220 and 180.300.

h. A participant in a covered transaction may rely upon a certification of a prospective participant in a lower tier covered transaction that is not debarred, suspended, ineligible, or voluntarily excluded from the covered transaction, unless it knows that the certification is erroneous. 2 CFR 180.300; 180.320, and 180.325. A participant is responsible for ensuring that its principals are not suspended, debarred, or otherwise ineligible to participate in covered transactions. 2 CFR 180.335. To verify the eligibility of its principals, as well as the eligibility of any lower tier prospective participants, each participant may, but is not required to, check the System for Award Management website (<https://www.sam.gov/>). 2 CFR 180.300, 180.320, and 180.325.

i. Nothing contained in the foregoing shall be construed to require the establishment of a system of records in order to render in good faith the certification required by this clause. The knowledge and information of the prospective participant is not required to exceed that which is normally possessed by a prudent person in the ordinary course of business dealings.

j. Except for transactions authorized under paragraph (f) of these instructions, if a participant in a covered transaction knowingly enters into a lower tier covered transaction with a person who is suspended, debarred, ineligible, or voluntarily excluded from participation in this transaction, in addition to other remedies available to the Federal Government, the department or agency may terminate this transaction for cause or default. 2 CFR 180.325.

2. Certification Regarding Debarment, Suspension, Ineligibility and Voluntary Exclusion – First Tier Participants:

a. The prospective first tier participant certifies to the best of its knowledge and belief, that it and its principals:

(1) Are not presently debarred, suspended, proposed for debarment, declared ineligible, or voluntarily excluded from participating in covered transactions by any Federal department or agency, 2 CFR 180.335;.

(2) Have not within a three-year period preceding this proposal been convicted of or had a civil judgment rendered against them for commission of fraud or a criminal offense in connection with obtaining, attempting to obtain, or performing a public (Federal, State, or local) transaction or contract under a public transaction; violation of Federal or State antitrust statutes or commission of embezzlement, theft, forgery, bribery, falsification or destruction of records, making false statements, or receiving stolen property, 2 CFR 180.800;

(3) Are not presently indicted for or otherwise criminally or civilly charged by a governmental entity (Federal, State or local) with commission of any of the offenses enumerated in paragraph (a)(2) of this certification, 2 CFR 180.700 and 180.800; and

(4) Have not within a three-year period preceding this application/proposal had one or more public transactions (Federal, State or local) terminated for cause or default. 2 CFR 180.335(d).

(5) Are not a corporation that has been convicted of a felony violation under any Federal law within the two-year period preceding this proposal (USDOT Order 4200.6 implementing appropriations act requirements); and

(6) Are not a corporation with any unpaid Federal tax liability that has been assessed, for which all judicial and administrative remedies have been exhausted, or have lapsed, and that is not being paid in a timely manner pursuant to an agreement with the authority responsible for collecting the tax liability (USDOT Order 4200.6 implementing appropriations act requirements).

b. Where the prospective participant is unable to certify to any of the statements in this certification, such prospective participant should attach an explanation to this proposal. 2 CFR 180.335 and 180.340.

3. Instructions for Certification - Lower Tier Participants:

(Applicable to all subcontracts, purchase orders, and other lower tier transactions requiring prior FHWA approval or estimated to cost \$25,000 or more - 2 CFR Parts 180 and 1200). 2 CFR 180.220 and 1200.220.

a. By signing and submitting this proposal, the prospective lower tier participant is providing the certification set out below.

b. The certification in this clause is a material representation of fact upon which reliance was placed when this transaction was entered into. If it is later determined that the prospective lower tier participant knowingly rendered an erroneous certification, in addition to other remedies available to the Federal Government, the department, or agency with which this transaction originated may pursue available remedies, including suspension and/or debarment.

c. The prospective lower tier participant shall provide immediate written notice to the person to which this proposal is submitted if at any time the prospective lower tier participant learns that its certification was erroneous by reason of changed circumstances. 2 CFR 180.365.

d. The terms "covered transaction," "debarred," "suspended," "ineligible," "participant," "person," "principal," and "voluntarily excluded," as used in this clause, are defined in 2 CFR Parts 180, Subpart I, 180.900 – 180.1020, and 1200. You may contact the person to which this proposal is

submitted for assistance in obtaining a copy of those regulations. "First Tier Covered Transactions" refers to any covered transaction between a recipient or subrecipient of Federal funds and a participant (such as the prime or general contractor). "Lower Tier Covered Transactions" refers to any covered transaction under a First Tier Covered Transaction (such as subcontracts). "First Tier Participant" refers to the participant who has entered into a covered transaction with a recipient or subrecipient of Federal funds (such as the prime or general contractor). "Lower Tier Participant" refers any participant who has entered into a covered transaction with a First Tier Participant or other Lower Tier Participants (such as subcontractors and suppliers).

e. The prospective lower tier participant agrees by submitting this proposal that, should the proposed covered transaction be entered into, it shall not knowingly enter into any lower tier covered transaction with a person who is debarred, suspended, declared ineligible, or voluntarily excluded from participation in this covered transaction, unless authorized by the department or agency with which this transaction originated. 2 CFR 1200.220 and 1200.332.

f. The prospective lower tier participant further agrees by submitting this proposal that it will include this clause titled "Certification Regarding Debarment, Suspension, Ineligibility and Voluntary Exclusion-Lower Tier Covered Transaction," without modification, in all lower tier covered transactions and in all solicitations for lower tier covered transactions exceeding the \$25,000 threshold. 2 CFR 180.220 and 1200.220.

g. A participant in a covered transaction may rely upon a certification of a prospective participant in a lower tier covered transaction that is not debarred, suspended, ineligible, or voluntarily excluded from the covered transaction, unless it knows that the certification is erroneous. A participant is responsible for ensuring that its principals are not suspended, debarred, or otherwise ineligible to participate in covered transactions. To verify the eligibility of its principals, as well as the eligibility of any lower tier prospective participants, each participant may, but is not required to, check the System for Award Management website (<https://www.sam.gov/>), which is compiled by the General Services Administration. 2 CFR 180.300, 180.320, 180.330, and 180.335.

h. Nothing contained in the foregoing shall be construed to require establishment of a system of records in order to render in good faith the certification required by this clause. The knowledge and information of participant is not required to exceed that which is normally possessed by a prudent person in the ordinary course of business dealings.

i. Except for transactions authorized under paragraph e of these instructions, if a participant in a covered transaction knowingly enters into a lower tier covered transaction with a person who is suspended, debarred, ineligible, or voluntarily excluded from participation in this transaction, in addition to other remedies available to the Federal Government, the department or agency with which this transaction originated may pursue available remedies, including suspension and/or debarment. 2 CFR 180.325.

Certification Regarding Debarment, Suspension, Ineligibility and Voluntary Exclusion--Lower Tier Participants:

1. The prospective lower tier participant certifies, by submission of this proposal, that neither it nor its principals:

(a) is presently debarred, suspended, proposed for debarment, declared ineligible, or voluntarily excluded from participating in covered transactions by any Federal department or agency, 2 CFR 180.355;

(b) is a corporation that has been convicted of a felony violation under any Federal law within the two-year period preceding this proposal (USDOT Order 4200.6 implementing appropriations act requirements); and

(c) is a corporation with any unpaid Federal tax liability that has been assessed, for which all judicial and administrative remedies have been exhausted, or have lapsed, and that is not being paid in a timely manner pursuant to an agreement with the authority responsible for collecting the tax liability. (USDOT Order 4200.6 implementing appropriations act requirements)

2. Where the prospective lower tier participant is unable to certify to any of the statements in this certification, such prospective participant should attach an explanation to this proposal.

XI. CERTIFICATION REGARDING USE OF CONTRACT FUNDS FOR LOBBYING

This provision is applicable to all Federal-aid construction contracts and to all related subcontracts which exceed \$100,000. 49 CFR Part 20, App. A.

1. The prospective participant certifies, by signing and submitting this bid or proposal, to the best of his or her knowledge and belief, that:

a. No Federal appropriated funds have been paid or will be paid, by or on behalf of the undersigned, to any person for influencing or attempting to influence an officer or employee of any Federal agency, a Member of Congress, an officer or employee of Congress, or an employee of a Member of Congress in connection with the awarding of any Federal contract, the making of any Federal grant, the making of any Federal loan, the entering into of any cooperative agreement, and the extension, continuation, renewal, amendment, or modification of any Federal contract, grant, loan, or cooperative agreement.

b. If any funds other than Federal appropriated funds have been paid or will be paid to any person for influencing or attempting to influence an officer or employee of any Federal agency, a Member of Congress, an officer or employee of Congress, or an employee of a Member of Congress in connection with this Federal contract, grant, loan, or cooperative agreement, the undersigned shall complete and submit Standard Form-LLL, "Disclosure Form to Report Lobbying," in accordance with its instructions.

2. This certification is a material representation of fact upon which reliance was placed when this transaction was made or entered into. Submission of this certification is a prerequisite for making or entering into this transaction imposed by 31 U.S.C. 1352. Any person who fails to file the required certification shall be subject to a civil penalty of not less than \$10,000 and not more than \$100,000 for each such failure.

3. The prospective participant also agrees by submitting its bid or proposal that the participant shall require that the language of this certification be included in all lower tier

subcontracts, which exceed \$100,000 and that all such recipients shall certify and disclose accordingly.

XII. USE OF UNITED STATES-FLAG VESSELS:

This provision is applicable to all Federal-aid construction contracts, design-build contracts, subcontracts, lower-tier subcontracts, purchase orders, lease agreements, or any other covered transaction. 46 CFR Part 381.

This requirement applies to material or equipment that is acquired for a specific Federal-aid highway project. 46 CFR 381.7. It is not applicable to goods or materials that come into inventories independent of an FHWA funded-contract.

When oceanic shipments (or shipments across the Great Lakes) are necessary for materials or equipment acquired for a specific Federal-aid construction project, the bidder, proposer, contractor, subcontractor, or vendor agrees:

1. To utilize privately owned United States-flag commercial vessels to ship at least 50 percent of the gross tonnage (computed separately for dry bulk carriers, dry cargo liners, and tankers) involved, whenever shipping any equipment, material, or commodities pursuant to this contract, to the extent such vessels are available at fair and reasonable rates for United States-flag commercial vessels. 46 CFR 381.7.
2. To furnish within 20 days following the date of loading for shipments originating within the United States or within 30 working days following the date of loading for shipments originating outside the United States, a legible copy of a rated, 'on-board' commercial ocean bill-of-lading in English for each shipment of cargo described in paragraph (b)(1) of this section to both the Contracting Officer (through the prime contractor in the case of subcontractor bills-of-lading) and to the Office of Cargo and Commercial Sealift (MAR-620), Maritime Administration, Washington, DC 20590. (MARAD requires copies of the ocean carrier's (master) bills of lading, certified onboard, dated, with rates and charges. These bills of lading may contain business sensitive information and therefore may be submitted directly to MARAD by the Ocean Transportation Intermediary on behalf of the contractor). 46 CFR 381.7.

**ATTACHMENT A - EMPLOYMENT AND MATERIALS
PREFERENCE FOR APPALACHIAN DEVELOPMENT
HIGHWAY SYSTEM OR APPALACHIAN LOCAL ACCESS
ROAD CONTRACTS (23 CFR 633, Subpart B, Appendix B)**

This provision is applicable to all Federal-aid projects funded under the Appalachian Regional Development Act of 1965.

1. During the performance of this contract, the contractor undertaking to do work which is, or reasonably may be, done as on-site work, shall give preference to qualified persons who regularly reside in the labor area as designated by the DOL wherein the contract work is situated, or the subregion, or the Appalachian counties of the State wherein the contract work is situated, except:

a. To the extent that qualified persons regularly residing in the area are not available.

b. For the reasonable needs of the contractor to employ supervisory or specially experienced personnel necessary to assure an efficient execution of the contract work.

c. For the obligation of the contractor to offer employment to present or former employees as the result of a lawful collective bargaining contract, provided that the number of nonresident persons employed under this subparagraph (1c) shall not exceed 20 percent of the total number of employees employed by the contractor on the contract work, except as provided in subparagraph (4) below.

2. The contractor shall place a job order with the State Employment Service indicating (a) the classifications of the laborers, mechanics and other employees required to perform the contract work, (b) the number of employees required in each classification, (c) the date on which the participant estimates such employees will be required, and (d) any other pertinent information required by the State Employment Service to complete the job order form. The job order may be placed with the State Employment Service in writing or by telephone. If during the course of the contract work, the information submitted by the contractor in the original job order is substantially modified, the participant shall promptly notify the State Employment Service.

3. The contractor shall give full consideration to all qualified job applicants referred to him by the State Employment Service. The contractor is not required to grant employment to any job applicants who, in his opinion, are not qualified to perform the classification of work required.

4. If, within one week following the placing of a job order by the contractor with the State Employment Service, the State Employment Service is unable to refer any qualified job applicants to the contractor, or less than the number requested, the State Employment Service will forward a certificate to the contractor indicating the unavailability of applicants. Such certificate shall be made a part of the contractor's permanent project records. Upon receipt of this certificate, the contractor may employ persons who do not normally reside in the labor area to fill positions covered by the certificate, notwithstanding the provisions of subparagraph (1c) above.

5. The provisions of 23 CFR 633.207(e) allow the contracting agency to provide a contractual preference for the use of mineral resource materials native to the Appalachian region.

6. The contractor shall include the provisions of Sections 1 through 4 of this Attachment A in every subcontract for work which is, or reasonably may be, done as on-site work.

FEDERAL AID PROVISIONS

December 1980

**NOTICE OF REQUIREMENT FOR AFFIRMATIVE ACTION TO ENSURE
EQUAL EMPLOYMENT OPPORTUNITY (EXECUTIVE ORDER 11246)**

1. The Offeror’s or Bidders attention is called to the “Equal Opportunity Clause” and the Standard Federal Equal Employment Opportunity Construction Contract Specifications” set forth therein.
2. The goals and timetables for minority and female participation, expressed in percentage terms for the Contractor’s aggregate workforce in each trade on all construction work in the covered area, are as follows:
3. Construction contractors which are participating in an approved Hometown Plan (see 41 CFR 60-4.5) are required to comply with the goals of the Hometown Plan with regard to construction work they perform in the area covered by the Hometown Plan. With regard to all their covered construction work, such contractors are required to comply with the following goals:

Goals for Female participation for each trade

AREA COVERED

Goals for women apply nationwide

GOALS AND TIMETABLES

Goals

Timetable	(Percent)
From April 1, 1978 until March 31, 1979	3.1
From April 1, 1979 until March 31, 1980	5.1
From April 1, 1980 until March 31, 1981	6.9

Goals for Minority Participation for Each Trade

<u>County</u>	<u>Goal (Percent)</u>	<u>County</u>	<u>Goal (Percent)</u>
Adair	4	Linn	4
Andrew	3.2	Livingston	10
Atchison	10	McDonald	2.3
Audrain	4	Macon	4
Barry	2.3	Madison	11.4
Barton	2.3	Maries	11.4
Bates	10	Marion	3.1
Benton	10	Mercer	10
Bollinger	11.4	Miller	4
Boone	6.3	Mississippi	11.4
Buchanan	3.2	Moniteau	4
Butler	11.4	Monroe	4
Caldwell	10	Montgomery	11.4
Callaway	4	Morgan	4

Clayton CBD Resurfacing – Phase 1
STP-5438(613)

Camden	4	New Madrid	26.5
Cape Girardeau	11.4	Newton	2.3
Carroll	10	Nodaway	10
Carter	11.4	Oregon	2.3
Cass	12.7	Osage	4
Cedar	2.3	Ozark	2.3
Chariton	4	Pemiscot	26.5
Christian	2	Perry	11.4
Clark	3.4	Pettis	10
Clay	12.7	Phelps	11.4
Clinton	10	Pike	3.1
Cole	4	Platte	12.7
Cooper	4	Polk	2.3
Crawford	11.4	Pulaski	2.3
Dade	2.3	Putnam	4
Dallas	2.3	Ralls	3.1
Daviess	10	Randolph	4
DeKalb	10	Ray	12.7
Dent	11.4	Reynolds	11.4
Douglas	2.3	Ripley	11.4
Dunklin	26.5	St. Charles	14.7
Franklin	14.7	St. Clair	2.3
Gasconade	11.4	St. Francois	11.4
Gentry	10	Ste. Genevieve	11.4
Greene	2	St. Louis City	14.7
Grundy	10	St. Louis County	14.7
Harrison	10	Saline	10
Henry	10	Schuyler	4
Hickory	2.3	Scotland	4
Holt	10	Scott	11.4
Howard	4	Shannon	2.3
Howell	2.3	Shelby	4
Iron	11.4	Stoddard	11.4
Jackson	12.7	Stone	2.3
Jasper	2.3	Sullivan	4
Jefferson	14.7	Taney	2.3
Johnson	10	Texas	2.3
Knox	4	Vernon	2.3
Laclede	2.3	Warren	11.4
Lafayette	10	Washington	11.4
Lawrence	2.3	Wayne	11.4
Lewis	3.1	Webster	2.3
Lincoln	11.4	Worth	10
		Wright	2.3

These goals are applicable to all of the contractor’s construction work (whether or not is Federal or federally assisted) performed in the covered area. If the contractor performs construction work in a geographical area located outside of the covered area, it shall apply the goals established for such geographical area where the work is actually performed. With regard to this second area, the contractor also is subject to the goals for both its federally involved and nonfederally involved construction.

The Contractor's compliance with the Executive Order and the regulations in 41 CFR Part 60-4 shall be based on Its Implementation of the Equal Opportunity Clause, specific affirmative action obligations required by the specifications set forth in 41 CFR 60-4.3(a), and its effort to meet the goals. The hours of minority and female employment and training must be substantially uniform throughout the length of the contract, and in each trade, and the Contractor shall make a good faith effort to employ minorities and women evenly on each of its projects. The transfer of minority, or female employees or trainees from Contractor to Contractor or from project to project for the sole purpose of meeting the Contractor's goals shall be a violation of the contract, the Executive Order and the regulations in 41 CFR Part 60-4. Compliance with the goals will be measured against the total work hours performed.

4. The Contractor shall provide written notification to the Director of the Office of Federal Contract Compliance Programs within 10 working days of award of any construction subcontract in excess of \$10,000 at any tier for construction work under the contract resulting from this solicitation. The notification shall list the name, address and telephone number of the subcontractor; employer identification number; estimated dollar amount of the subcontract; estimated starting and completion dates of the subcontract; and the geographical area in which the subcontract is to be performed.
5. As used in this Notice, and in the contract resulting from this solicitation, the "covered area" of the county, route and limits described in the proposal for the work.

July 1986

STANDARD FEDERAL EQUAL EMPLOYMENT OPPORTUNITY CONSTRUCTION
CONTRACT SPECIFICATIONS (EXECUTIVE ORDER 11246)

1. As used in these specifications:
 - a. "Covered area" means the geographical area described in the solicitation which this contract resulted.
 - b. "Director" mean Director, Office of Federal Contract Compliance Programs, United States Department of labor, or any person to who the Director delegates authority;
 - c. "Employer Identification Number" means the Federal Social Security number used on the Employer's quarterly Federal Tax Return, U.S. Treasury Department Form 941;
 - d. "Minority" includes;
 - (i) Black (all persons having origins in any of the Black African racial groups not of Hispanic origin);
 - (ii) Hispanic (all persons of Mexican, Puerto Rican, Cuban, Central or South American or other Spanish Culture or origin, regardless of race);
 - (iii) Asian and pacific islander (all persons having origins in any of the original peoples of the Far East, southeast Asia, the Indian Subcontinent, or the Pacific Islands; and
 - (iv) American Indian or Alaskan Native (all persons having origins in any of the original peoples of North American and maintain identifiable affiliations through membership and participation or community identifications.
2. Whenever the Contractor, or any Subcontractor at any tier, subcontractors a portion of the work involving any construction trade, it shall physically include in each subcontract in excess of \$10,000 the provisions of these specifications and the Notice which contains the applicable goals for minority and female participation and which is set forth in the solicitations from which this contract resulted.

3. If the Contract is participating (pursuant to 41 CFR 60-4.5) in a Hometown Plan approved by the U.S. Department of Labor in the covered area either individually or through the association, its affirmative action obligations on all work in the Plan area (including goals and timetables) shall be in accordance with the Plan for those trades which have unions participating in the Plan. Contractors must be able to demonstrate their participation in and compliance with the provisions of any such Hometown Plan. Each Contractor or Subcontractor participating in an approved Plan is individually required to comply with its obligation under the EEO clause, and to make a good faith effort to achieve each goal under the Plan in each trade in which it has employees. The overall good faith performance by other Contractors or Subcontractors toward a goal in an approved Plan does not excuse any covered Contractor's or Subcontractors' failure to take good faith efforts to achieve the Plan goals and timetables.
4. The Contractor shall implement the specific affirmative action standards provided in paragraphs 7a through 7p of these specifications. The goals set forth in the solicitation from which this contact resulted are expressed as percentages of the total hours of employment and training of minority and female utilization the Contractor should reasonably be able to achieve in each construction trade in which it has employees in the covered area. Covered Construction contractors performing construction work in geographical areas where they do not have a Federal or federally assisted construction contract shall apply the minority and female goals established for the geographical area where the work is being performed. Goals are published periodically in the Federal Register in notice form, and such notices may be obtained from any Office of Federal Contract Compliance Programs office or from Federal procurement contracting officers. The Contractor is expected to make substantially uniform progress toward its goals in each craft during the period specified.
5. Neither the provisions of any collective bargaining agreement, nor the failure by a union with who the Contractor has a collective bargaining agreement, to refer either minorities or women shall excuse the Contractor's obligations under these specifications, Executive Order 11246, or the regulations promulgated pursuant thereto.
6. In order for the nonworking training hours or apprentices and trainees to be counted in meeting the goal, such apprentices and trainees must be employed by the Contractor during the training period, and the Contractor must have made a commitment to employ the apprentices and trainees at the completion of their training, subject to the availability of employment opportunities. Trainees must be trained pursuant to training programs approved by the U.S. Department of Labor.
7. The contractor shall take specific affirmative actions to ensure equal employment opportunity. The evaluation of the Contractor's compliance with these specifications shall be used its effort to achieve maximum results from its actions. The Contractor shall document these efforts fully, and shall implement affirmative action steps at least as extensive as the following:
 - a. Ensure and maintain a working environment free of harassment, intimidation, and coercion at all sites, and all facilities at which the Contractor's employees are assigned to work. The Contractor shall specifically ensure that all foremen, superintendents, and other on-site supervisory personnel are aware of and carry out the Contractor's obligation to maintain such a working environment, with specific attention to minority or female individuals working at such sites or in such facilities.
 - b. Establish and maintain a current list of minority and female recruitment sources, provide written notification to minority and female recruitment sources and to community organizations when the Contractor or its unions have employment opportunities available, and maintain a record of the organizations' responses.
 - c. Maintain a current file or the names, addresses and telephone numbers of each minority and female off-the-street applicant and minority or female referral from a union, a recruitment source or community organization and what action was taken with respect to each such individual. If such

individual was sent to the union hiring hall for referral and was not referred back to the Contractor by the union or, if referred not employed by the contractor, this shall be documented in the file with the reason therefore, along with whatever additional actions the Contractor may have taken.

- d. Provide immediate written notification to the Director when the union or unions with which the Contractor has as collective bargaining agreement has not referred to the contractor a minority person or woman sent by the Contractor, or when the Contractor has other information that the union referral process has impeded the Contractor's efforts to meet its obligations.
- e. Develop on-the-job training opportunities and/or participate in training programs for the area which expressly include minorities and women, including upgrading programs and apprenticeship and trainee programs relevant of the contractor's employment needs, especially those programs funded or approved by the Department of Labor. The contractor shall provide notice of these programs to the sources complied under 7b above.
- f. Disseminate the Contractor's EEO policy by providing notice of the policy to unions and training programs and requesting their cooperation in assisting the Contractor in meeting its EEO obligations; by including it in any policy manual and collective bargaining agreement by publicizing it in the company newspaper, annual report, etc., by specific review of the policy with all management personnel and with all minority and female employees at least one a year; and by posting the company EEO policy on bulletin boards accessible to all employees at each location where construction work is performed.
- g. Review, at least annually, the company's EEO policy and affirmative action obligations under these specifications with all employees having any responsibility for hiring, assignment, layoff, termination or other employment decisions including specific review of these items with on-site supervisory personnel such as superintendents, General foreman, etc., prior to the initiation of construction work at any job site. A written record shall be made and maintained identifying the time and place of these meetings, person attending, subject matter discussed, and the disposition of the subject matter.
- h. Disseminate the Contractor's EEO policy externally by including it in any advertising in the news media, specifically including minority and female news media and providing written notification to and discussing the contractor's EEO policy with other Contractors and Subcontractors with who the Contractor does or anticipates doing business.
- i. Direct is a recruitment effort, both oral and written, to minority female and community organizations, to schools with minority and female students and to minority and female recruitment and training organizations serving the Contractor's recruitment area and employment needs. Not later than one month prior to the date for the acceptance or applicants for apprenticeship or other training by any recruitment source, the Contractor shall send written notification to organizations such as the above, describing the openings, screening procedures, and test to be used in the selection process.
- j. Encourage present minority and female employees to recruit other minority persons and women and, where reasonable, provide after school, summer vacations employment to minority and female youth both on the site and in other areas or contractor's workforce.
- k. Validate all tests and other selection requirements where there is an obligation to do so under 41 CFR Part 60-3.

- l. Conduct, at least annually, an inventory and evaluation at least of all minority and female personnel for promotional opportunities and encourage these employees to seek or to prepare for, through appropriate training, etc. such opportunities.
 - m. Ensure that seniority practices, job classifications, work assignments and other personnel practices, do not have a discriminatory effect by continually monitoring all personnel and employment related activities to ensure that the EEO policy and the Contractor's obligation under these specifications are being carried out.
 - n. Ensure that all facilities and company activities are non-segregated except that separate or single-user toilet and necessary changing facilities shall be provided to assure privacy between the sexes.
 - o. Document and maintain a record of all solicitations or offers for subcontracts from minority and female construction contractors and suppliers, including circulation of solicitations to minority and female contractor associations and other business associations.
 - p. Conduct a review, at least annually, of all supervisors' adherence to and performance under the Contractor's EEO policies and affirmative action obligations.
8. Contractors are encouraged to participate in voluntary associations which assist in fulfilling one or more of their affirmative action obligations (7a through 7p). The efforts of a contractor association, joint contractor union, contractor community, or other similar group of which the contractor is a member and participant, may be asserted as fulfilling anyone or more of its obligations under 7a through 7p of these specifications provided that the contractor actively participates in the group, makes every effort to assure that the group has a positive impact on the employment of minorities and women in the industry, ensures that the concrete benefits of the program are reflected in the contractor's minority and female workforce participation, makes a good faith effort to meet its individual goals and timetables, and can provide access to documentation which demonstrates the effectiveness of actions taken on behalf of the contractor. The obligation to comply, however, is the Contractor's and failure of such a group to fulfill an obligation shall not be a defense for the Contractor's noncompliance.
9. A single goal for minorities and a separate single goal for women have been established to provide equal employment opportunity and to take affirmative action for all minority groups, both male and female, and all women, both minority and non-minority. Consequently, the group is employed in a substantially disparate manner (for example, even though the Contractor has achieved its goals for women generally, the Contractor may be in violation of the executive order if a specific minority group of women is underutilized).
10. The Contractor shall not use the goals and timetables or affirmative action standards to discriminate against any person because of race, color, religion, sex, or national origin.
11. The Contractor shall not enter into any Subcontract with any person or firm debarred from Government contract pursuant to Executive Order 11246.
12. The Contractor shall carry out such sanctions and penalties for violation of these specifications and of the Equal Opportunity Clause, including suspension, termination and cancellation of existing subcontracts as may be imposed or ordered pursuant to Executive Order 11246, as amended, and its implementing regulations, by the Office of Federal Contract Compliance Programs. Any Contractor who fails to carry out such sanctions and penalties shall be in violation of these specifications and Executive Order 11246, as amended.
13. The Contractor, in fulfilling its obligations under these specifications, shall implement specific affirmative action steps, at least as extensive as those standards prescribed in paragraph 7 of these specifications, so as to achieve maximum results from its efforts to ensure equal employment opportunity. If the Contractor fails to comply with

the requirements of the Executive Order, the implementing regulations, or these specifications, the Direct shall proceed in accordance with 41 CFR 60-4.8.

14. The Contractor shall designate a responsible official to monitor all employment related activity to ensure that the company EEO policy is being carried out to submit reports relating to the provisions hereof as may be required by the Government and to keep records. Records shall at least include for each employee the name, address, telephone numbers, construction trade, union affiliation if any, employee identification number when assigned, social security number, race, sex, status, (e.g. mechanic, apprentice, trainee, helper, or laborer), dates of changes in status, hours worked per week in the indicated trade, rat of pay, and locations at which the work was performed. Records shall be maintained in an easily understandable and retrievable form; however, to the degree that existing records satisfy this requirement, contractors shall not be required to maintain separate records.
15. Nothing herein provided shall be constructed as a limitation upon the application of other laws which establish different standard of compliance or upon the application of requirements for the hiring of local or other area residents (e.g. those under the Public Works Employment Action of 1977 and the Community Development Block Grant Program.

OPERATING POLICY STATEMENT

The contractor shall accept as his operating policy the following statement, or one of equal coverage, which is designed to further the provision of equal employment opportunity to all persons without regard to their race, color, religion, sex, or national origin, and to promote the full realization of equal employment opportunity through a positive continuing program.

“It is the policy of this company to assure that applicants are employed, and that employees are treated during employment without regard to their race, religion, sex, color, or national origin. Such action shall include: employment, upgrading, demotion, or transfer, recruitment or recruitment advertising; layoff or termination; rates of pay or other forms of compensation; and selection for training, including apprenticeship, pre-apprenticeship, and/or on-the-job training.”

SUPPLEMENTAL REPORTING REQUIREMENTS

- A. The Contractor will keep such records as are necessary to determine compliance with the contractor’s equal employment opportunity obligations. The records kept by the contractor will be designed to indicate the number of minority and non-minority group members and women employed in each work classification on the project.
- B. All such records must be retained for a period of three years following completion of the contract work and shall be available at reasonable times and places for inspection by authorized representatives of the State Highway Agency and the Federal Highway Administration.
- C. The contractor and each covered subcontractor will submit to the State Highway Agency, for the month of July, for the duration of the project, a report (Form PR-1391) “Federal-Aid Highway Construction Contractors Annual EEO Report”, indicating the number of minority, women and non-minority group employees currently engaged in each work classification required by the contract work.

NONDISCRIMINATION IN EMPLOYMENT

July 1990

The following provisions are added by the State to the Required Contract Provisions of Federal-Aid Contracts.

The contractor is advised that the exemptions referred to in the Required Contract Provisions, Federal-Aid contracts under Section II, Nondiscrimination, Paragraph 3g, with respect to contracts and subcontracts, are substantial and are to be found in Chapter 60, Office of Federal Contract Compliance, Equal Employment Opportunity, Department of Labor (33 Federal Register 7804-7812, May 28, 1968, effective July 1, 1968, Chapter 60, Title 41, Code of Federal Regulations), by which contracts and subcontracts of \$10,000 or less and certain contracts and subcontracts for indefinite quantities are exempt.

The two pertinent exemption clauses are as follows:

60-1.5 Exemptions

- (a) General – (1) Transactions of \$10,000 or under. Contracts and Subcontractors not exceeding \$10,000, other than Government bills of lading, and other than contract and subcontracts with depositories of Federal funds in any amount and with financial institutions which are issuing and paying agents for U.S. savings bonds and savings notes, are exempt from the requirements of the equal opportunity clause. In determining the applicability of this exemption to any federally assisted construction contract, or subcontract thereunder, the amount of such contract or subcontract rather than the amount of the Federal financial assistance shall govern. No agency, contractor, or subcontractor shall procure supplies or services in a manner so as to avoid applicability of the equal opportunity clause: Provided, that where a contractor has contracts or subcontracts with the Government in any 12-month period which have an aggregate total value (or can reasonably be expected to have an aggregate total value) exceeding \$10,000, the \$10,000 or under exemption does not apply, and the contracts are subject to the order and the regulation issued pursuant thereto regardless of whether any single contracts exceeds \$10,000.

STATE WAGE RATES

Missouri

Division of Labor Standards

WAGE AND HOUR SECTION

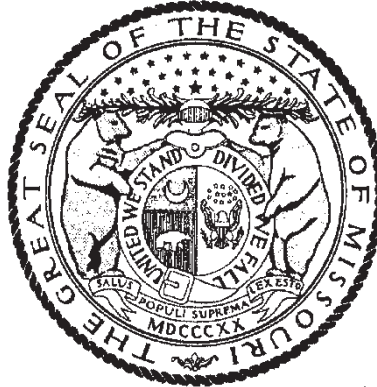

MICHAEL L. PARSON, Governor

Annual Wage Order No. 30

Section 100
ST. LOUIS COUNTY

In accordance with Section 290.262 RSMo 2000, within thirty (30) days after a certified copy of this Annual Wage Order has been filed with the Secretary of State as indicated below, any person who may be affected by this Annual Wage Order may object by filing an objection in triplicate with the Labor and Industrial Relations Commission, P.O. Box 599, Jefferson City, MO 65102-0599. Such objections must set forth in writing the specific grounds of objection. Each objection shall certify that a copy has been furnished to the Division of Labor Standards, P.O. Box 449, Jefferson City, MO 65102-0449 pursuant to 8 CSR 20-5.010(1). A certified copy of the Annual Wage Order has been filed with the Secretary of State of Missouri.

Original Signed by _____

Todd Smith, Director
Division of Labor Standards

Filed With Secretary of State: _____ **March 10, 2023**

Last Date Objections May Be Filed: **April 10, 2023**

Prepared by Missouri Department of Labor and Industrial Relations

OCCUPATIONAL TITLE	**Prevailing Hourly Rate
Asbestos Worker	\$66.97
Boilermaker	\$41.15*
Bricklayer	\$62.54
Carpenter	\$61.56
Lather	
Linoleum Layer	
Millwright	
Pile Driver	
Cement Mason	\$58.25
Plasterer	
Communications Technician	\$62.85
Electrician (Inside Wireman)	\$73.29
Electrician Outside Lineman	\$58.76
Lineman Operator	
Lineman - Tree Trimmer	
Groundman	
Groundman - Tree Trimmer	
Elevator Constructor	\$96.60
Glazier	\$65.67
Ironworker	\$67.11
Laborer	\$52.47
General Laborer	
First Semi-Skilled	
Second Semi-Skilled	
Mason	\$50.74
Marble Mason	
Marble Finisher	
Terrazzo Worker	
Terrazzo Finisher	
Tile Setter	
Tile Finisher	
Operating Engineer	\$67.06
Group I	
Group II	
Group III	
Group III-A	
Group IV	
Group V	
Painter	\$51.81
Plumber	\$75.30
Pipe Fitter	
Roofer	\$56.75
Sheet Metal Worker	\$72.05
Sprinkler Fitter	\$78.94
Truck Driver	\$41.15*
Truck Control Service Driver	
Group I	
Group II	
Group III	
Group IV	

*The Division of Labor Standards received fewer than 1,000 reportable hours for this occupational title. The public works contracting minimum wage is established for this occupational title using data provided by Missouri Economic Research and Information Center.

**The Prevailing Hourly Rate includes any applicable fringe benefit amounts for each occupational title as defined in RSMO Section 290.210.

Heavy Construction Rates for
ST. LOUIS County

Section 100

OCCUPATIONAL TITLE	**Prevailing Hourly Rate
Carpenter	\$62.80
Millwright	
Pile Driver	
Electrician (Outside Lineman)	\$58.76
Lineman Operator	
Lineman - Tree Trimmer	
Groundman	
Groundman - Tree Trimmer	
Laborer	\$53.14
General Laborer	
Skilled Laborer	
Operating Engineer	\$67.79
Group I	
Group II	
Group III	
Group IV	
Truck Driver	\$46.49
Truck Control Service Driver	
Group I	
Group II	
Group III	
Group IV	

Use Heavy Construction Rates on Highway and Heavy construction in accordance with the classifications of construction work established in 8 CSR 30-3.040(3).

Use Building Construction Rates on Building construction in accordance with the classifications of construction work established in 8 CSR 30-3.040(2).

If a worker is performing work on a heavy construction project within an occupational title that is not listed on the Heavy Construction Rate Sheet, use the rate for that occupational title as shown on the Building Construction Rate Sheet.

*The Division of Labor Standards received fewer than 1,000 reportable hours for this occupational title. Public works contracting minimum wage is established for this occupational title using data provided by Missouri Economic Research and Information Center.

**The Prevailing Hourly Rate includes any applicable fringe benefit amounts for each occupational title.

OVERTIME and HOLIDAYS

OVERTIME

For all work performed on a Sunday or a holiday, not less than twice (2x) the prevailing hourly rate of wages for work of a similar character in the locality in which the work is performed or the public works contracting minimum wage, whichever is applicable, shall be paid to all workers employed by or on behalf of any public body engaged in the construction of public works, exclusive of maintenance work.

For all overtime work performed, not less than one and one-half (1½) the prevailing hourly rate of wages for work of a similar character in the locality in which the work is performed or the public works contracting minimum wage, whichever is applicable, shall be paid to all workers employed by or on behalf of any public body engaged in the construction of public works, exclusive of maintenance work or contractual obligation. For purposes of this subdivision, "**overtime work**" shall include work that exceeds ten hours in one day and work in excess of forty hours in one calendar week; and

A thirty-minute lunch period on each calendar day shall be allowed for each worker on a public works project, provided that such time shall not be considered as time worked.

HOLIDAYS

January first;
The last Monday in May;
July fourth;
The first Monday in September;
November eleventh;
The fourth Thursday in November; and
December twenty-fifth;

If any holiday falls on a Sunday, the following Monday shall be considered a holiday.

FEDERAL WAGE RATES

Superseded General Decision Number: MO20220001

State: Missouri

Construction Types: Heavy and Highway

Counties: Missouri Statewide.

HEAVY AND HIGHWAY CONSTRUCTION PROJECTS

Note: Contracts subject to the Davis-Bacon Act are generally required to pay at least the applicable minimum wage rate required under Executive Order 14026 or Executive Order 13658. Please note that these Executive Orders apply to covered contracts entered into by the federal government that are subject to the Davis-Bacon Act itself, but do not apply to contracts subject only to the Davis-Bacon Related Acts, including those set forth at 29 CFR 5.1(a)(2)-(60).

If the contract is entered into on or after January 30, 2022, or the contract is renewed or extended (e.g., an option is exercised) on or after January 30, 2022:	. Executive Order 14026 generally applies to the contract. . The contractor must pay all covered workers at least \$16.20 per hour (or the applicable wage rate listed on this wage determination, if it is higher) for all hours spent performing on the contract in 2023.
If the contract was awarded on or between January 1, 2015 and January 29, 2022, and the contract is not renewed or extended on or after January 30, 2022:	. Executive Order 13658 generally applies to the contract. . The contractor must pay all covered workers at least \$12.15 per hour (or the applicable wage rate listed on this wage determination, if it is higher) for all hours spent performing on that contract in 2023.

The applicable Executive Order minimum wage rate will be adjusted annually. If this contract is covered by one of the Executive Orders and a classification considered necessary for performance of work on the contract does not appear on this wage determination, the contractor must still submit a conformance request.

Additional information on contractor requirements and worker protections under the Executive Orders is available at <http://www.dol.gov/whd/govcontracts>.

Modification Number	Publication Date
0	01/06/2023
1	01/27/2023
2	03/03/2023

3	03/17/2023
4	03/24/2023
5	04/14/2023
6	05/19/2023
7	05/26/2023
8	06/16/2023
9	06/30/2023
10	08/18/2023
11	09/08/2023

CARP002-002 05/01/2023

ST. LOUIS COUNTY AND CITY

	Rates	Fringes
Carpenters.....	\$ 40.34	21.25

 CARP005-006 05/01/2021

CASS (Richards-Gebauer AFB ONLY), CLAY, JACKSON, PLATTE AND RAY
 COUNTIES

	Rates	Fringes
Carpenters:		
CARPENTERS & LATHERS.....	\$ 41.37	18.90
MILLWRIGHTS & PILEDRIVERS...	\$ 41.37	18.90

 CARP011-001 05/01/2022

	Rates	Fringes
Carpenter and Piledriver		
ADAIR, AUDRAIN (West of Hwy 19), BOONE, CALLAWAY, CHARITON, COLE, COOPER, HOWARD, KNOX, LINN, MACON, MILLER, MONITEAU, MONROE, OSAGE, PUTNAM, RANDOLPH, SCHUYLER, SHELBY AND SULLIVAN COUNTIES.....	\$ 34.06	19.20
ATCHISON, ANDREW, BATES, CALDWELL, CARROLL, DAVIESS, DEKALB, GENTRY, GRUNDY, HARRISON, HENRY, HOLT, LIVINGSTON, MERCER, NODAWAY, ST. CLAIR, SALINE AND WORTH COUNTIES.....	\$ 32.43	19.20
AUDRAIN (East of Hwy.19), RALLS, MARION, LEWIS, CLARK AND SCOTLAND COUNTIES.	\$ 34.07	19.20
BARRY, BARTON, CAMDEN, CEDAR, CHRISTIAN, DADE, DALLAS, DOUGLAS, GREENE, HICKORY, JASPER, LACLEDE, LAWRENCE, MCDONALD, NEWTON, OZARK, POLK, STONE, TANEY, VERNON, WEBSTER AND WRIGHT COUNTIES.	\$ 32.00	19.20
BENTON, MORGAN AND PETTIS...	\$ 32.48	19.20
BOLLINGER, BUTLER, CAPE GIRARDEAU, DUNKLIN, MISSISSIPPI, NEW MADRID,		

PEMISCOT, PERRY, STE. GENEVIEVE, SCOTT, STODDARD AND WAYNE COUNTIES.....	\$ 33.90	19.20
BUCHANAN, CLINTON, JOHNSON AND LAFAYETTE COUNTIES.....	\$ 33.20	19.20
CARTER, HOWELL, OREGON AND RIPLEY COUNTIES.....	\$ 32.77	19.20
CRAWFORD, DENT, GASCONADE, IRON, MADISON, MARIES, MONTGOMERY, PHELPS, PULASKI, REYNOLDS, SHANNON AND TEXAS COUNTIES.....	\$ 33.89	19.20
FRANKLIN COUNTY.....	\$ 37.59	19.20
JEFFERSON AND ST. CHARLES COUNTIES.....	\$ 39.94	19.50
LINCOLN COUNTY.....	\$ 35.91	19.20
PIKE, ST. FRANCOIS AND WASHINGTON COUNTIES.....	\$ 34.74	19.20
WARREN COUNTY.....	\$ 36.38	19.20

ELEC0001-002 07/17/2022

BOLLINGER, BUTLER, CAPE GIRARDEAU, CARTER, DUNKLIN, FRANKLIN,
IRON, JEFFERSON, LINCOLN, MADISON, MISSISSIPPI, NEW MADRID,
PEMISCOT, PERRY, REYNOLDS, RIPLEY, ST. CHARLES, ST. FRANCOIS,
ST. LOUIS (City and County), STE. GENEVIEVE, SCOTT, STODDARD,
WARREN, WASHINGTON AND WAYNE COUNTIES

	Rates	Fringes
Electricians.....	\$ 43.56	29.10

ELEC0002-001 09/04/2022

ADAIR, AUDRAIN, BOONE, CALLAWAY, CAMDEN, CARTER, CHARITON,
CLARK, COLE, COOPER, CRAWFORD, DENT, FRANKLIN, GASCONADE,
HOWARD, HOWELL, IRON, JEFFERSON, KNOX, LEWIS, LINCON, LINN,
MACON, MARIES, MARION, MILLER, MONITEAU, MONROE, MONTGOMERY,
MORGAN, OREGON, OSAGE, PERRY, PHELPS, PIKE, PULASKI, PUTNAM,
RALLS, RANDOLPH, REYNOLDS, RIPLEY, ST. CHARLES, ST. FRANCOIS,
ST. LOUIS (City and County), STE. GENEVIEVE, SCHUYLER,
SCOTLAND, SHANNON, SHELBY, SULLIVAN, TEXAS, WARREN AND
WASHINGTON COUNTIES

	Rates	Fringes
Line Construction:		
Equipment Operator.....	\$ 44.16	23.14
Groundman & Truck Driver....	\$ 33.74	19.34
Lineman & Cable Splicer.....	\$ 51.45	25.81

ELEC0053-004 01/01/2023

	Rates	Fringes
Line Construction: (ANDREW, ATCHINSON, BARRY, BARTON, BUCHANAN, CALDWELL, CEDAR, CHRISTIAN, CLINTON, DADE, DALLAS, DAVIES,, DEKALB, DOUGLAS, GENTRY, GREENE, GRUNDY, HARRISON, HICKORY, HOLT, JASPER, LACLEDE,		

LAWRENCE, LIVINGSTON,
 MCDONALD, MERCER, NEWTON,
 NODAWAY, OZARK, POLK, ST.
 CLAIR, STONE, TANEY, VERNON,
 WEBSTER, WORTH AND WRIGHT
 COUNTIES)

Groundman Powderman.....	\$ 34.25	18.81
Groundman.....	\$ 31.96	18.03
Lineman Operator.....	\$ 46.74	23.09
Lineman.....	\$ 51.82	24.89

Line Construction; (BATES,
 BENTON, CARROLL, CASS, CLAY,
 HENRY, JACKSON, JOHNSON,
 LAFAYETTE, PETTIS, PLATTE,
 RAY AND SALINE COUNTIES)

Groundman Powderman.....	\$ 33.58	18.34
Groundman.....	\$ 31.33	17.60
Lineman Operator.....	\$ 45.60	22.48
Lineman.....	\$ 50.31	24.11

 ELEC0095-001 06/01/2020

BARRY, BARTON, CEDAR, DADE, JASPER, LAWRENCE, MCDONALD, NEWTON,
 ST CLAIR, AND VERNON COUNTIES

Rates Fringes

Electricians:

Cable Splicers.....	\$ 25.40	12.19
Electricians.....	\$ 27.43	17.44

 ELEC0124-007 09/28/2021

BATES, BENTON, CARROLL, CASS, CLAY, COOPER, HENRY, JACKSON,
 JOHNSON, LAFAYETTE, MORGAN, PETTIS, PLATTE, RAY AND SALINE
 COUNTIES:

Rates Fringes

Electricians.....	\$ 41.79	23.67
-------------------	----------	-------

 ELEC0257-003 03/01/2023

AUDRAIN (Except Cuivre Township), BOONE, CALLAWAY, CAMDEN,
 CHARITON, COLE, CRAWFORD, DENT, GASCONADE, HOWARD, MARIES,
 MILLER, MONITEAU, OSAGE, PHELPS AND RANDOLPH COUNTIES

Rates Fringes

Electricians:

Cable Splicers.....	\$ 30.42	16.085
Electricians.....	\$ 37.00	20.88

 ELEC0350-002 12/01/2022

ADAIR, AUDRAIN (East of Highway 19), CLARK, KNOX, LEWIS, LINN,
 MACON, MARION, MONROE, MONTGOMERY, PIKE, PUTNAM, RALLS,
 SCHUYLER, SCOTLAND, SHELBY AND SULLIVAN COUNTIES

Rates Fringes

Electricians.....\$ 35.50 19.94

* ELEC0453-001 09/01/2023

	Rates	Fringes
Electricians:		
CHRISITAN, DALLAS,		
DOUGLAS, GREENE, HICKORY,		
HOWELL, LACLEDE, OREGON,		
OZARK, POLK, SHANNON,		
WEBSTER and WRIGHT COUNTIES..\$ 36.08	36.08	17.91
PULASKI and TEXAS COUNTIES..\$ 36.08	36.08	17.91
STONE and TANEY COUNTIES....\$ 26.62	26.62	17.11

ELEC0545-003 06/01/2023

ANDREW, BUCHANAN, CLINTON, DEKALB, ATCHISON, HOLT, MERCER,
 GENTRY, HARRISON, DAVIESS, GRUNDY, WORTH, LIVINGSTON, NODAWAY,
 AND CALDWELL COUNTIES

	Rates	Fringes
Electricians:.....\$ 36.75	36.75	20.40

ELEC0702-004 01/02/2023

BOLLINGER, BUTLER, CAPE GIRARDEAU, DUNKLIN, MADISON,
 MISSISSIPPI, NEW MADRID, PEMISCOT, SCOTT, STODDARD AND WAYNE
 COUNTIES

	Rates	Fringes
Line Construction:		
Groundman - Class A.....\$ 33.63	33.63	29%+8.35
Groundman-Equipment Operator Class II (all other equipment).....\$ 42.65	42.65	29%+8.35
Heavy-Equipment Operator Class I (all crawler type equipment D-4 and larger)...\$ 48.67	48.67	29%+8.35
Lineman.....\$ 59.34	59.34	29%+8.35

ENGI0101-001 05/01/2020

ANDREW, ATCHISON, BATES, BENTON, BUCHANAN, CALDWELL, CARROLL,
 CHARITON, CLINTON, COOPER, DAVIESS, DEKALB, GENTRY, GRUNDY,
 HARRISON, HENRY, HOLT, HOWARD, JOHNSON, LAFAYETTE, LINN,
 LIVINGSTON, MERCER, NODAWAY, PETTIS, SALINE, SULLIVAN AND WORTH
 COUNITES

	Rates	Fringes
Power equipment operators:		
GROUP 1.....\$ 34.73	34.73	18.20
GROUP 2.....\$ 34.33	34.33	18.20
GROUP 3.....\$ 32.33	32.33	18.20

POWER EQUIPMENT OPERATORS CLASSIFICATIONS

GROUP 1: Asphalt roller operator, finish; asphalt paver and
 spreader; asphalt plant operator; auto grader or trimmer or

sub-grader; backhoe; blade operator (all types); boilers - 2; booster pump on dredge; bulldozer operator; boring machine (truck or crane mounted); clamshell operator; concrete mixer paver; concrete plant operator; concrete pump operator; crane operator; derrick or derrick trucks; ditching machine; dragline operator; dredge engineman; dredge operator; drill cat with compressor mounted (self-contained) or similar type self-propelled rotary drill (not air tract); drilling or boring machine (rotary-self-propelled); finishing machine operator; greaser; high loader-fork lift-skid loader (all types); hoisting engineer (2 active drums); locomotive operator (standard guage); mechanics and welders (field and plants); mucking machine operator; pile drive operator; pitman crane or boom truck (all types); push cat; quad track; scraper operators (all types); shovel operator; sideboom cats; side discharge spreader; skimmer scoop operators; slip form paver operator (CMI, Rex, Gomeco or equal); la tourneau rooter (all tiller types); tow boat operator; truck crane; wood and log chippers (all types).

GROUP 2: A-frame truck operator; articulated dump truck; back filler operator; boilers (1); chip spreader; churn drill operator; compressor; concrete mixer operator, skip loader; concrete saws (self-propelled); conveyor operator; crusher operator; distributor operator; elevating grader operator; farm tractor (all attachments); fireman rig; float operator; form grade operator; hoisting engine (one drum); maintenance operator; multiple compactor; pavement breaker, self-propelled hydra-hammer (or similar type); paymill operator; power shield; pumps; roller operator (with or without blades); screening and washing plant; self-propelled street broom or sweeper; siphons and jets; straw blower; stump cutting machine; siphons and jets; tank car heater operator (combination boiler and booster); welding machine; vibrating machine operator (not hand held); welding machine.

GROUP 3: (a) Oiler;
(b) Oiler driver
(c) Mechanic.

HOURLY PREMIUMS:

THE FOLLOWING CLASSIFICATIONS SHALL RECEIVE (\$.25) ABOVE GROUP 1 RATE: Dragline operator - 3 yds. & over; shovel 3 yds. & over; clamshell 3 yds. & over; Crane, rigs or piledrivers, 100' of boom or over (incl. jib.), hoist - each additional active drum over 2 drums

THE FOLLOWING CLASSIFICATIONS SHALL RECEIVE (\$.50) ABOVE GROUP 1 RATE: Tandem scoop operator; crane, rigs or piledrivers 150' to 200' of boom (incl. jib.)

THE FOLLOWING CLASSIFICATIONS SHALL RECEIVE (\$.75) ABOVE GROUP 1 RATE: Crane rigs, or piledrivers 200 ft. of boom or over (including jib.)

ENGI0101-005 04/01/2022

CASS, CLAY, JACKSON, PLATTE AND RAY COUNTIES

Rates Fringes

Power equipment operators:

GROUP 1.....	\$ 38.42	20.44
GROUP 2.....	\$ 37.38	20.44
GROUP 3.....	\$ 32.91	20.44
GROUP 4.....	\$ 36.26	20.44

POWER EQUIPMENT OPERATORS CLASSIFICATIONS

GROUP 1: Asphalt roller operator, finish; asphalt paver and spreader; asphalt plant operator; auto grader or trimmer or sub-grader; backhoe; blade operator (all types); boilers-2; booster pump on dredge; boring machine (truck or crane mounted); bulldozer operator; clamshell operator; concrete cleaning decontamination machine operator; concrete mixer paver; concrete plant operator; concrete pump operator; crane operator; derrick or derrick trucks; ditching machine; dragline operator; dredge engineman; dredge operator; drillcat with compressor mounted (self-contained) or similar type self propelled rotary drill (not air tract); drilling or boring machine (rotary - self-propelled); finishing machine operator; greaser; heavy equipment robotics operator/mechanic; horizontal directional drill operator; horizontal directional drill locator; loader-forklift - skid loader (all types); hoisting engineer (2 active drums); locomotive operator (standard guage); master environmental maintenance mechanic; mechanics and welders (field and plants); mucking machine operator; piledrive operator; pitman crane or boom truck (all types); push cat; quad-track; scraper operators (all types); shovel operator; side discharge spreader; sideboom cats; skimmer scoop operator; slip-form paver (CMI, REX, Gomaco or equal); la tourneau rooter (all tiller types); tow boat operator; truck crane; ultra high perssure waterjet cutting tool system operator/mechanic; vacuum blasting machine operator/mechanic; wood and log chippers (all types)

GROUP 2: ""A"" Frame truck operator; back filler operator; boilers (1); chip spreader; churn drill operator; concrete mixer operator, skip loader; concrete saws (self-propelled); conveyor operator; crusher operator; distributor operator; elevating grader operator; farm tractor (all attachments); fireman rig; float operator; form grader operator; hoisting engine (1 drum); maintenance operator; multiple compactor; pavement breaker, self-propelled hydra- hammer (or similar type); power shield; paymill operator; pumps; siphons and jets; stump cutting machine; tank car heater operator (combination boiler and booster); compressor; roller operator (with or without blades); screening and washing plant; self-propelled street broom or sweeper; straw blower; tank car heater operator (combination boiler and booster); vibrating machine operator (not hand held)

GROUP 3: Oilers

GROUP 4: Oiler Driver (All Types)

FOOTNOTE:

HOURLY PREMIUMS FOLLOWING CLASSIFICATIONS SHALL RECEIVE (\$1.00) ABOVE GROUP 1 RATE:

Clamshells - 3 yd. capacity or over; Cranes or rigs, 80 ft. of boom or over (including jib); Draglines, 3 yd. capacity or over;

Piledrivers 80 ft. of boom or over (including jib);

Shovels & backhoes, 3 yd. capacity or over.

BARRY, BARTON, CAMDEN, CEDAR, CHRISTIAN, DADE, DALLAS, DOUGLAS,
 GREENE, HICKORY, JASPER, LACLEDE, LAWRENCE, MCDONALD, NEWTON,
 OZARK, POLK, ST. CLAIR, STONE, TANEY, VERNON, WEBSTER AND
 WRIGHT COUNTIES and CITY OF SPRINGFIELD

	Rates	Fringes
Power equipment operators:		
GROUP 1.....	\$ 31.72	14.88
GROUP 2.....	\$ 31.37	14.88
GROUP 3.....	\$ 31.17	14.88
GROUP 4.....	\$ 29.12	14.88

POWER EQUIPMENT OPERATORS CLASSIFICATIONS

GROUP 1: Asphalt finishing machine & trench widening spreader; asphalt plant console operator; autograder; automatic slipform paver; backhoe; blade operator - all types; boat operator - tow; boilers-2; central mix concrete plant operator; clamshell operator; concrete mixer paver; crane operator; derrick or derrick trucks; ditching machine; dozer operator; dragline operator; dredge booster pump; dredge engineman; dredge operator; drill cat with compressor mounted on cat; drilling or boring machine rotary self-propelled; highloader; hoisting engine - 2 active drums; launch hammer wheel; locomotive operator; - standard guage; mechanic and welders; mucking machine; off-road trucks; piledriver operator; pitman crane operator; push cat operator; quad trac; scoop operator - all types; shovel operator; sideboom cats; skimmer scoop operators; trenching machine operator; truck crane.

GROUP 2: A-frame; asphalt hot-mix silo; asphalt plant fireman (drum or boiler); asphalt plant man; asphalt plant man; asphalt plant mixer operator; asphalt roller operator; backfiller operator; barber-greene loader; boat operator (bridges and dams); chip spreader; concrete mixer operator - skip loader; concrete plant operator; concrete pump operator; crusher operator; dredge oiler; elevating grader operator; fork lift; greaser-fleet; hoisting engine - 1; locomotive operator - narrow gauge; multiple compactor; pavement breaker; powerbroom - self-propelled; power shield; rooter; side discharge concrete spreader; slip form finishing machine; stumpcutter machine; throttle man; tractor operator (over 50 h.p.); winch truck.

GROUP 3: Boilers - 1; chip spreader (front man); churn drill operator; clef plane operator; concrete saw operator (self-propelled); curb finishing machine; distributor operator; finishing machine operator; flex plane operator; float operator; form grader operator; pugmill operator; roller operator, other than high type asphalt; screening & washing plant operator; siphons & jets; sub-grading machine operator; spreader box operator, self-propelled (not asphalt); tank car heater operator (combination boiler & booster); tractor operator (50 h.p. or less); Umac, Ulric or similar spreader; vibrating machine operator, not hand;

GROUP 4: Grade checker; Oiler; Oiler-Driver

HOURLY PREMIUMS:

The following classifications shall receive \$.25 above GROUP 1 rate:

Clamshells - 3 yds. or over; Cranes - Rigs or Piledrivers, 100 ft. of boom or over (including jib); Draglines - 3 yds. or over; Hoists - each additional active drum over 2 drums; Shovels - 3 yds. or over;

The following classifications shall receive \$.50 above GROUP 1 rate:

Tandem scoop operator; Cranes - Rigs or Piledrivers, 150 ft. to 200 ft. of boom (including jib); Tandem scoop.

The following classifications shall receive \$.75 above GROUP 1 rate:

Cranes - Rigs or Piledrivers, 200 ft. of boom or over (including jib.).

ENGI0513-004 05/03/2023

FRANKLIN, JEFFERSON, LINCOLN, ST CHARLES, AND WARREN COUNTIES

	Rates	Fringes
Power equipment operators:		
GROUP 1.....	\$ 41.01	29.63
GROUP 2.....	\$ 41.01	29.63
GROUP 3.....	\$ 39.71	29.63
GROUP 4.....	\$ 39.26	29.63

POWER EQUIPMENT OPERATORS CLASSIFICATIONS

GROUP 1: Backhoe, Cable; Backhoe, Hydraulic (2 cu yds bucket and under regardless of attachment, one oiler for 2 or 3, two oilers for 4 through 6); Backhoe, Hydraulic over 2 cu yds; Cableway; Crane, Crawler or Truck; Crane, Hydraulic - Truck or Cruiser mounted, 16 tons and over; Crane, Locomotive; crane with boom including jib over 100 ft from pin to pin; Crane using rock socket tool; Derrick, Steam; Derrick Car and Derrick Boat; Dragline, 7 cu yds and over; Dredge; Gradall, Crawler or tire mounted; Locomotive, Gas, Steam & other powers; Pile Driver, Land or Floating; Scoop, Skimmer; Shovel, Power (Electric, Gas, Steam or other powers); Shovel, Power (7 cu yds and over); Switch Boat; Whirley; Air Tugger with air compressor; Anchor Placing Barge; Asphalt Spreader; Athey Force Feeder Loader, self-propelled; Backfilling Machine; Boat Operator - Push Boat or Tow Boat (job site); Boiler, High Pressure Breaking in Period; Boom Truck, Placing or Erecting; Boring Machine, Footing Foundation; Bullfloat; Cherry Picker; Combination Concrete Hoist and Mixer (such as Mixermobile); Compressor, Two 125 CFM and under; Compressor, Two through Four over 125 CFM; Compressor when operator runs throttle; Concrete Breaker (Truck or Tractor mounted); Concrete Pump (such as Pumpcrete machine); Concrete Saw (self-propelled); Concrete Spreader; Conveyor, Large (not selfpropelled) hoisting or moving brick and concrete into, or into and on floor level, one or both; Crane, Cimbing (such as Linden); Crane, Hydraulic - Rough Terrain, self-propelled; Crane, Hydraulic - Truck or Cruiser mounted - under 16 tons; Drilling machine - Self-powered, used for earth or rock drilling or boring (wagon drills and any hand drills obtaining power from other souces including concrete breakers, jackhammers

and Barco equipmnet no engineer required); Elevating Grader; Engine Man, Dredge; Excavator or Powerbelt Machine; Finishing Machine, self- propelled oscillating screed; Forklift; Generators, Two through Six 30 KW or over; Grader, Road with power blade; Greaser; Highlift; Hoist, Concrete and Brick (Brick cages or concrete skips operating or on tower, Towermobile, or similar equipment); Hoist, Three or more drums in use; Hoist, Stack; Hydro-Hammer; Lad-A-Vator, hoisting brick or concrete; Loading Machine such as Barber-Greene; Mechanic on job site

GROUP 2: Air Tugger with plant air; Boiler (for power or heating shell of building or temporary enclosures in connection with construction work); Boiler, Temporary; Compressor, One over 125 CFM; Compressor, truck mounted; Conveyor, Large (not self- propelled); Conveyor, Large (not self- propelled) moving brick and concrete (distributing) on floor level; Curb Finishing Machine; Ditch Paving Machine; Elevator (outside); Endless Chain Hoist; Fireman (as required); Form Grader; Hoist, One Drum regardless of size (except brick or concrete); Lad-A-Vator, other hoisting; Manlift; Mixer, Asphalt, over 8 cu ft capacity; Mixer, one bag capacity or less; Mixer, without side loader, two bag capacity or more; Mixer, with side loader, regardless of size, not Paver; Mud Jack (where mud jack is used in conjenction with an air compressor, operator shall be paid \$.55 per hour in addition to his basic hourly rate for covering both operations); Pug Mill operator; Pump, Sump - self powered, automatic controlled over 2"; Scissor Lift (used for hoisting); Skid Steer Loader; Sweeper, Street; Tractor, small wheel type 50 HP and under with grader blade and similar equipment; Welding Machine, One over 400 amp; Winch, operating from truck

GROUP 3: Boat operator - outboard motor, job site; Conveyors (such as Con-Vay-It) regardless of how used; Elevator (inside); Heater operator, 2 through 6; Sweeper, Floor

GROUP 4: Crane type

HOURLY PREMIUMS:

Backhoe, Hydraulic 2 cu yds or less without oiler - \$2.00;
Crane, climbing (such as Linden) - \$.50;
Crane, Pile Driving and Extracting - \$.50
Crane with boom (including job) over
100 ft from pin to pin - add \$.01 per foot
to maximum of \$4.00);
Crane, using rock socket tool - \$.50;
Derrick, diesel, gas or electric hoisting material
and erecting steel (150 ft or more above ground) - \$.50;
Dragline, 7 cu yds and over - \$.50;
Hoist, Three or more drums in use - \$.50;
Scoop, Tandem - \$.50;
Shovel, Power - 7 cu yds and over - \$.50;
Tractor, Tandem Crawler - \$.50;
Tunnel, man assigned to work in tunnel or
tunnel shaft - \$.50;
Wrecking, when machines are working on
second floor or higher - \$.50

ENGI0513-006 05/01/2022

GIRARDEAU, CARTER, CLARK, COLE, CRAWFORD, DENT, DUNKLIN, GASCONADE, HOWELL, IRON, KNOX, LEWIS, MACON, MADISON, MARIES, MARION, MILLER, MISSISSIPPI, MONITEAU, MONROE, MONTGOMERY, MORGAN, NEW MADRID, OREGON, OSAGE, PEMISCOT, PERRY, PHELPS, PIKE, PULASKI, PUTNAM, RALLS, RANDOLPH, REYNOLDS, RIPLEY, ST. FRANCOIS, STE. GENEVIEVE, SCHUYLER, SCOTLAND, SCOTT, SHANNON, SHELBY, STODDARD, TEXAS, WASHINGTON, AND WAYNE COUNTIES

	Rates	Fringes
Power equipment operators:		
GROUP 1.....	\$ 33.24	28.75
GROUP 2.....	\$ 32.89	28.75
GROUP 3.....	\$ 32.69	28.75
GROUP 4.....	\$ 29.04	28.75

POWER EQUIPMENT OPERATORS CLASSIFICATIONS

GROUP 1: Asphalt finishing machine & trench widening spreader, asphalt plant console operator; autograder; automatic slipform paver; back hoe; blade operator - all types; boat operator tow; boiler two; central mix concrete plant operator; clam shell operator; concrete mixer paver; crane operator; derrick or derrick trucks; ditching machine; dozer operator; dragline operator; dredge booster pump; dredge engineman; dredge operator; drill cat with compressor mounted on cat; drilling or boring machine rotary self-propelled; highloader; hoisting engine 2 active drums; launchhammer wheel; locomotive operator standrad guage; mechanics and welders; mucking machine; piledriver operator; pitman crane operator; push cat operator; quad-trac; scoop operator; sideboom cats; skimmer scoop operator; trenching machine operator; truck crane, shovel operator.

GROUP 2: A-Frame; asphalt hot-mix silo; asphalt roller operator asphalt plant fireman (drum or boiler); asphalt plant man; asphalt plant mixer operator; backfiller operator; barber-greene loader; boat operator (bridge & dams); chip spreader; concrete mixer operator skip loader; concrete plant operator; concrete pump operator; dredge oiler; elevating graded operator; fork lift; grease fleet; hoisting engine one; locomotive operator narrow guage; multiple compactor; pavement breaker; powerbroom self-propelled; power shield; rooter; slip-form finishing machine; stumpcutter machine; side discharge concrete spreader; throttleman; tractor operator (over 50 hp); winch truck; asphalt roller operator; crusher operator.

GROUP 3: Spreader box operator, self-propelled not asphalt; tractor operator (50 h.p. or less); boilers one; chip spreader (front man); churn drill operator; compressor over 105 CFM 2-3 pumps 4" & over; 2-3 light plant 7.5 KWA or any combination thereof; clef plane operator; compressor maintenance operator 2 or 3; concrete saw operator (self-propelled); curb finishing mancine; distributor operator; finishing machine operator; flex plane operator; float operator; form grader operator; pugmill operator; riller operator other than high type asphalt; screening & washing plant operator; siphons & jets; subgrading machine operator; tank car heater (combination boiler & booster); ulmac, ulric or similar spreader; vibrating machine operator; hydrobroom.

GROUP 4: Oiler; grout machine; oiler driver; compressor over 105 CFM one; conveyor operator one; maintenance operator; pump 4" & over one.

FOOTNOTE: HOURLY PREMIUMS

Backhoe hydraulic, 2 cu. yds. or under Without oiler - \$2.00
 Certified Crane Operator - \$1.50;
 Certified Hazardous Material Operator \$1.50;
 Crane, climbing (such as Linden) - \$0.50;
 Crane, pile driving and extracting - \$0.50;
 Crane, with boom (including jib) over 100' from pin to pin add \$0.01 per foot to maximum of \$4.00;
 Crane, using rock socket tool - \$0.50;
 Derrick, diesel, gas or electric, hoisting material and erecting steel (150' or more above the ground) - \$0.50;
 Dragline, 7 cu. yds, and over - \$0.50;
 Hoist, three or more drums in use - \$0.50; Scoop, Tandem - \$0.50;
 Shovel, power - 7 cu. yds. or more - \$0.50;
 Tractor, tandem crawler - \$0.50;
 Tunnel, man assigned to work in tunnel or tunnel shaft - \$0.50;
 Wrecking, when machine is working on second floor or higher - \$0.50;

 ENGI0513-007 05/03/2023

ST. LOUIS CITY AND COUNTY

	Rates	Fringes
Power equipment operators:		
GROUP 1.....	\$ 41.01	29.63
GROUP 2.....	\$ 41.01	29.63
GROUP 3.....	\$ 39.71	29.63
GROUP 4.....	\$ 39.26	29.63

POWER EQUIPMENT OPERATORS CLASSIFICATIONS

GROUP 1: Backhoe, cable or hydraulic; cableway; crane crawler or truck; crane, hydraulic-truck or cruiser mounted 16 tons & over; crane locomotive; derrick, steam; derrick car & derrick boat; dragline; dredge; gradall, crawler or tire mounted; locomotive, gas, steam & other powers; pile driver, land or floating; scoop, skimmer; shovel, power (steam, gas, electric or other powers); switch boat; whirley.

GROUP 2: Air tugger w/air compressor; anchor-placing barge; asphalt spreader; atehy force feeder loader (self-propelled); backfilling machine; backhoe-loader; boat operator-push boat or tow boat (job site); boiler, high pressure breaking in period; boom truck, placing or erecting; boring machine, footing foundation; bull- float; cherry picker; combination concrete hoist & mixer (such as mixer mobile); compressor (when operator runs throttle); concrete breaker (truck or tractor mounted); concrete pump, such as pump-crete machine; concrete saw (self-propelled), concrete spreader; conveyor, large (not self-propelled), hoisting or moving brick and concrete into, or into and on floor level, one or both; crane, hydraulic-rough terrain, self-propelled; crane hydraulic-truck or cruiser mounted-under 16 tons; drilling machines, self-powered use

for earth or rock drilling or boring (wagon drills and any hand drills obtaining power from other sources including concrete breakers, jackhammers and barco equipment-no engineer required); elevating grader; engineman, dredge; excavator or powerbelt machine; finishing machine, self-propelled oscillating screed; forklift; grader, road with power blade; highlift. greaser; hoist, stack, hydro-hammer; loading machine (such as barber-greene); machanic, on job site; mixer, pipe wrapping machines; plant asphalt; plant, concrete producing or ready-mix job site; plant heating-job site; plant mixing-job site; plant power, generating-job site; pumps, two through six self-powered over 2"; pumps, electric submersible, two through six, over 4"; quad-track; roller, asphalt, top or sub-grade; scoop, tractor drawn; spreader box; sub-grader; tie tamper; tractor-crawler, or wheel type with or without power unit, power take-offs and attachments regardless of size; trenching machine; tunnel boring machine; vibrating machine automatic, automatic propelled; welding machines (gasoline or diesel) two through six; well drilling machine

GROUP 3: Conveyor, large (not self-propelled); conveyor, large (not self-propelled) moving brick and concrete distributing) on floor level; mixer two or more mixers of one bag capacity or less; air tugger w/plant air; boiler, for power or heating on construction projects; boiler, temporary; compressor (mounted on truck; curb finishing machine; ditch paving machine; elevator; endless chain hoist; form grader; hoist, one drum regardless of size; lad-a-vator; manlift; mixer, asphalt, over 8 cu. ft. capacity, without side loader, 2 bag capacity or more; mixer, with side loader, regardless of size; pug mill operator; pump, sump-self-powered, automatic controlled over 2" during use in connection with construction work; sweeper, street; welding machine, one over 400 amp.; winch operating from truck; scissor lift (used for hoisting); tractor, small wheel type 50 h.p. & under with grader blade & similar equipment; Oiler on dredge and on truck crane.

GROUP 4: Boat operator-outboard motor (job site); conveyor (such as con-vay-it) regardless of how used; sweeper, floor

HOURLY PREMIUMS:

Backhoe, hydraulic	
2 cu. yds. or under without oiler	\$2.00
Certified Crane Operator	1.50
Certified Hazardous Material Operator	1.50
Crane, climbing (such as Linden)	.50
Crane, pile driving and extracting	.50
Crane, with boom (including jib) over 100' (from pin to pin) add \$.01 per foot to maximum of	4.00
Crane, using rock socket tool	.50
Derrick, diesel, gas or electric, hoisting material and erecting steel (150' or more above ground)	.50
Dragline, 7 cu. yds. and over	.50
Hoist, three (3) or more drums in use	.50
Scoop, Tandem	.50
Shovel, power - 7 cu. yds. or more	.50
Tractor, tandem crawler	.50
Tunnel, man assigned to work in tunnel or tunnel shaft	.50
Wrecking, when machine is working on second floor or higher	.50

IRON0010-012 04/01/2023

	Rates	Fringes
Ironworkers:		
ANDREW, BARTON, BENTON, CAMDEN, CEDAR, CHARITON, CHRISTIAN, COOPER, DADE, DALLAS, DAVIESS, DE KALB, GENTRY, GREENE, GRUNDY, HARRISON, HICKORY, HOLT, HOWARD, LACLEDE, LINN, LIVINGSTON, MERCER, MONITEAU, MORGAN, NODAWAY, PETTIS, POLK, PUTNAM, RANDLOPH, ST. CLAIR, SULLIVAN, TANEY, VERNON, WEBSTER, WRIGHT and WORTH Counties and portions of ADAIR, BOONE, MACON, MILLER and RANDOLPH Counties.....	\$ 33.50	33.38
ATCHISON, BATES, BUCHANAN, CALDWELL, CARROLL, CASS, CLAY, CLINTON, HENRY, JACKSON, JOHNSON, LAFAYETTE, PETTIS, PLATTE, SALINE, AND RAY COUNTIES....	\$ 36.50	33.38

IRON0321-002 08/01/2022

DOUGLAS, HOWELL and OZARK COUNTIES

	Rates	Fringes
Ironworker.....	\$ 23.50	19.96

IRON0396-004 08/04/2021

ST. LOUIS (City and County), ST. CHARLES, JEFFERSON, IRON,
FRANKLIN, LINCOLN, WARREN, WASHINGTON, ST. FRANCOIS, STE.
GENEVIEVE, and REYNOLDS Counties; and portions of MADISON,
PERRY, BOLLINGER, WAYNE, and CARTER Counties

	Rates	Fringes
Ironworker.....	\$ 36.71	28.96

IRON0396-009 08/04/2021

AUDRAIN, CALLAWAY, COLE, CRAWFORD, DENT, GASCONADE, MARIES,
MONTGOMERY, OSAGE, PHELPS, PIKE, PULASKI, TEXAS and WRIGHT
Counties; and portions of BOONE, CAMDEN, DOUGLAS, HOWELL,
LACLEDE, MILLER, MONROE, OREGON, SHANNON and RALLS Counties

	Rates	Fringes
Ironworker.....	\$ 32.24	28.96

IRON0577-005 06/01/2023

ADAIR, CLARK, KNOX, LEWIS, MACON, MARION, MONROE, RALLS,
SCHUYLER, SCOTLAND, AND SHELBY COUNTIES

	Rates	Fringes
Ironworker.....	\$ 31.55	25.05

IRON0584-004 06/01/2023		

BARRY, JASPER, LAWRENCE, MCDONALD, NEWTON AND STONE Counties

	Rates	Fringes
Ironworkers:.....	\$ 29.00	16.20

IRON0782-003 08/01/2022		

CAPE GIRARDEAU, MISSISSIPPI, NEW MADRID, SCOTT, & STODDARD
Counties; and portions of BOLLINGER, BUTLER, CARTER, DUNKLIN,
MADISON, PEMISCOT, PERRY, RIPLEY, and WAYNE Counties

	Rates	Fringes
Ironworkers:		
Locks, Dams, Bridges and other major work on the Mississippi and Ohio River only.....	\$ 35.13	28.27
All Other Work.....	\$ 30.73	24.12

LAB00042-003 03/01/2023		

ST. LOUIS (City and County)

	Rates	Fringes
LABORER		
Plumber Laborer.....	\$ 36.65	17.12

LAB00042-005 03/01/2023		

ST. LOUIS (City and County)

	Rates	Fringes
LABORER		
Dynamiter, Powderman.....	\$ 36.65	17.12
Laborers, Flaggers.....	\$ 36.65	17.12
Wrecking.....	\$ 36.65	17.12

LAB00110-005 05/01/2023		

Jefferson and Washington Counties

	Rates	Fringes
LABORER (Jefferson County)		
GROUP 1.....	\$ 35.49	15.62
GROUP 2.....	\$ 36.09	15.62
LABORER (Washington County)		
GROUP 1.....	\$ 32.98	15.62
GROUP 2.....	\$ 32.98	15.62

LABORERS CLASSIFICATIONS

GROUP 1 - General laborer-flagman, carpenter tenders; salamander Tenders; Dump Man; Ticket Takers; loading trucks under bins, hoppers, and conveyors; track man; cement handler; dump man on earth fill; georgie buggy man; material batch hopper man; spreader on asphalt machine; material mixer man (except on manholes); coffer dams; riprap pavers rock, block or brick; scaffolds over ten feet not self-supported from ground up; skip man on concrete paving; wire mesh setters on concrete paving; all work in connection with sewer, water, gas, gasoling, oil, drainage pipe, conduit pipe, tile and duct lines and all other pipe lines; power tool operator; all work in connection with hydraulic or general dredging operations; form setters, puddlers (paving only); straw blower nozzle man; asphalt plant platform man; chuck tender; crusher feeder; men handling creosote ties or creosote materials; men working with and handling epoxy material; topper of standing trees; feeder man on wood pulverizers, board and willow mat weavers and cabelee tiers on river work; deck hands; pile dike and revetment work; all laborers working on underground tunnels less than 25 ft. where compressed air is not used; abutement and pier hole men working six (6) ft. or more below ground; men working in coffer dams for bridge piers and footing in the river; barco tamper; jackson or any other similar tamp; cutting torch man; liners, curb, gutters, ditch lines; hot mastic kettlemen; hot tar applicator; hand blade operator; mortar men or brick or block manholes; rubbing concrete, air tool operator under 65 lbs.; caulker and lead man; chain or concrete saw under 15 h.p.; signal Gan; Guard rail and sign erectors.

GROUP 2 - Skilled laborers - Vibrator man; asphalt raker; head pipe layer on sewer work; batterboard man on pipe and ditch work; cliff scalers working from bosun's chairs; scaffolds or platforms on dams or power plants over 10 ft. high; air tool operator over 65 lbs.; stringline man on concrete paving; sandblast man; laser beam man; wagon drill; churn drill; air track drill and all other similar type drills, gunite nozzle man; pressure grout man; screed man on asphalt; concrete saw 15 h.p. and over; grade checker; strigline man on electronic grade control; manhole builder; dynamite man; powder man; welder; tunnel man; waterblaster - 1000 psi or over; asbestos and/or hazardous waste removal and/or disposal

LAB00579-005 05/01/2023

	Rates	Fringes
LABORER (ANDREW, ATCHISON, BUCHANAN, CALDWELL, CLINTON, DAVISS, DEKALB, GENTRY, GRUNDY, HARRISON, HOLT, LIVINGSTON, MERCER, NODAWAY and WORTH COUNTIES.)		
GROUP 1.....	\$ 29.04	16.59
GROUP 2.....	\$ 29.39	16.59
LABORER (BARRY, BARTON, BATES, BENTON, CAMDEN, CARROLL, CEDAR, CHRISTIAN, DADE, DALLAS, DOUGLAS,		

GREENE, HENRY. HICKORY,
 JASPER, JOHNSON, LACLEDE,
 LAWRENCE, MCDONALD, MORGAN,
 NEWTON, OZARK, PETTIS, POLK,
 ST. CLAIR, SALINE, STONE,
 TANEY, VERNON, WEBSTER and
 WRIGHT COUNTIES)

GROUP 1.....	\$ 28.23	15.60
GROUP 2.....	\$ 28.78	15.60

LABORER (LAFAYETTE COUNTY)

GROUP 1.....	\$ 29.78	15.85
GROUP 2.....	\$ 30.13	15.85

LABORERS CLASSIFICATIONS

GROUP 1: General Laborers - Carpenter tenders; salamander tenders; loading trucks under bins; hoppers & conveyors; track men & all other general laborers; air tool operator; cement handler-bulk or sack; dump man on earth fill; georgie buggy man; material batch hopper man; material mixer man (except on manholes); coffer dams; riprap pavers - rock, block or brick; signal man; scaffolds over ten feet not self-supported from ground up; skipman on concrete paving; wire mesh setters on concrete paving; all work in connection with sewer, water, gas, gasoline, oil drainage pipe, conduit pipe, tile and duct lines and all other pipe lines; power tool operator, all work in connection with hydraulic or general dredging operations; puddlers (paving only); straw blower nozzle man; asphalt plant platform man; chuck tender; crusher feeder; men handling creosote ties or creosote materials; men working with and handling epoxy material or materials (where special protection is required); rubbing concrete; topper of standing trees; batter board man on pipe and ditch work; feeder man on wood pulverizers; board and willow mat weavers and cable tiers on river work; deck hands; pile dike and revetment work; all laborers working on underground tunnels less than 25 feet where compressed air is not used; abutment and pier hole men working six (6) feet or more below ground; men working in coffer dams for bridge piers and footings in the river; ditchliners; pressure groutmen; caulker; chain or concrete saw; cliffscalers working from scaffolds, bosuns' chairs or platforms on dams or power plants over (10) feet above ground; mortarmen on brick or block manholes; toxic and hazardous waste work.

GROUP 2: Skilled Laborers - Head pipe layer on sewer work; laser beam man; Jackson or any other similar tamp; cutting torch man; form setters; liners and stringline men on concrete paving, curb, gutters; hot mastic kettleman; hot tar applicator; sandblasting and gunite nozzle men; air tool operator in tunnels; screed man on asphalt machine; asphalt raker; barco tamper; churn drills; air track drills and all similar drills; vibrator man; stringline man for electronic grade control; manhole builders-brick or block; dynamite and powder men; grade checker.

 LAB00660-004 05/01/2023

Clark, Knox, Lewis, Marion, Pike, Ralls, Scotland, Shelby Counties

LABORER

GROUP 1.....	\$ 32.98	15.62
GROUP 2.....	\$ 32.98	15.62

LABORERS CLASSIFICATIONS

GROUP 1 - General laborer-flagman, carpenter tenders; salamander Tenders; Dump Man; Ticket Takers; loading trucks under bins, hoppers, and conveyors; track man; cement handler; dump man on earth fill; georgie buggy man; material batch hopper man; spreader on asphalt machine; material mixer man (except on manholes); coffer dams; riprap pavers rock, block or brick; scaffolds over ten feet not self-supported from ground up; skip man on concrete paving; wire mesh setters on concrete paving; all work in connection with sewer, water, gas, gasoling, oil, drainage pipe, conduit pipe, tile and duct lines and all other pipe lines; power tool operator; all work in connection with hydraulic or general dredging operations; form setters, puddlers (paving only); straw blower nozzle man; asphalt plant platform man; chuck tender; crusher feeder; men handling creosote ties or creosote materials; men working with and handling epoxy material; topper of standing trees; feeder man on wood pulverizers, board and willow mat weavers and cabelee tiers on river work; deck hands; pile dike and revetment work; all laborers working on underground tunnels less than 25 ft. where compressed air is not used; abutement and pier hole men working six (6) ft. or more below ground; men working in coffer dams for bridge piers and footing in the river; barco tamper; jackson or any other similar tamp; cutting torch man; liners, curb, gutters, ditch lines; hot mastic kettlemen; hot tar applicator; hand blade operator; mortar men or brick or block manholes; rubbing concrete, air tool operator under 65 lbs.; caulker and lead man; chain or concrete saw under 15 h.p.; signal Gan; Guard rail and sign erectors.

GROUP 2 - Skilled laborers - Vibrator man; asphalt raker; head pipe layer on sewer work; batterboard man on pipe and ditch work; cliff scalers working from bosun's chairs; scaffolds or platforms on dams or power plants over 10 ft. high; air tool operator over 65 lbs.; stringline man on concrete paving; sandblast man; laser beam man; wagon drill; churn drill; air track drill and all other similar type drills, gunite nozzle man; pressure grout man; screed man on asphalt; concrete saw 15 h.p. and over; grade checker; strigline man on electronic grade control; manhole builder; dynamite man; powder man; welder; tunnel man; waterblaster - 1000 psi or over; asbestos and/or hazardous waste removal and/or disposal

LAB00660-006 03/01/2023

Lincoln, Montgomery, St Charles and Warren Counties

	Rates	Fringes
LABORER (Common or General).....	\$ 36.91	15.62

LAB00662-001 05/01/2023

Callaway, Cole, Miller and Moniteau Counties

	Rates	Fringes
LABORER		
GROUP 1.....	\$ 32.98	15.62
GROUP 2.....	\$ 32.98	15.62

LABORERS CLASSIFICATIONS

GROUP 1 - General laborer-flagman, carpenter tenders; salamander Tenders; Dump Man; Ticket Takers; loading trucks under bins, hoppers, and conveyors; track man; cement handler; dump man on earth fill; georgie buggy man; material batch hopper man; spreader on asphalt machine; material mixer man (except on manholes); coffer dams; riprap pavers rock, block or brick; scaffolds over ten feet not self-supported from ground up; skip man on concrete paving; wire mesh setters on concrete paving; all work in connection with sewer, water, gas, gasoling, oil, drainage pipe, conduit pipe, tile and duct lines and all other pipe lines; power tool operator; all work in connection with hydraulic or general dredging operations; form setters, puddlers (paving only); straw blower nozzle man; asphalt plant platform man; chuck tender; crusher feeder; men handling creosote ties or creosote materials; men working with and handling epoxy material; topper of standing trees; feeder man on wood pulverizers, board and willow mat weavers and cable ties on river work; deck hands; pile dike and revetment work; all laborers working on underground tunnels less than 25 ft. where compressed air is not used; abutment and pier hole men working six (6) ft. or more below ground; men working in coffer dams for bridge piers and footing in the river; barco tamper; jackson or any other similar tamp; cutting torch man; liners, curb, gutters, ditch lines; hot mastic kettlemen; hot tar applicator; hand blade operator; mortar men or brick or block manholes; rubbing concrete, air tool operator under 65 lbs.; caulker and lead man; chain or concrete saw under 15 h.p.; signal Gan; Guard rail and sign erectors.

GROUP 2 - Skilled laborers - Vibrator man; asphalt raker; head pipe layer on sewer work; batterboard man on pipe and ditch work; cliff scalers working from bosun's chairs; scaffolds or platforms on dams or power plants over 10 ft. high; air tool operator over 65 lbs.; stringline man on concrete paving; sandblast man; laser beam man; wagon drill; churn drill; air track drill and all other similar type drills, gunite nozzle man; pressure grout man; screed man on asphalt; concrete saw 15 h.p. and over; grade checker; strigline man on electronic grade control; manhole builder; dynamite man; powder man; welder; tunnel man; waterblaster - 1000 psi or over; asbestos and/or hazardous waste removal and/or disposal

LAB00663-002 04/01/2023

CASS, CLAY, JACKSON, PLATTE AND RAY COUNTIES

	Rates	Fringes
LABORER		
GROUP 1.....	\$ 34.15	17.06
GROUP 2.....	\$ 35.36	17.06

LABORERS CLASSIFICATIONS

GROUP 1: General laborers, Carpenter tenders, salamander tenders, loading trucks under bins, hoppers and conveyors, track men and all other general laborers, air tool operator, cement handler (bulk or sack), chain or concrete saw, deck hands, dump man on earth fill, Georgie Buggies man, material batch hopper man, scale man, material mixer man (except on manholes), coffer dams, abutments and pier hole men working below ground, riprap pavers rock, black or brick, signal man, scaffolds over ten feet not self-supported from ground up, skipman on concrete paving, wire mesh setters on concrete paving, all work in connection with sewer, water, gas, gasoling, oil, drainage pipe, conduit pipe, tile and duct lines and all other pipelines, power tool operator, all work in connection with hydraulic or general dredging operations, straw blower nozzle man, asphalt plant platform man, chuck tender, crusher feeder, men handling creosote ties on creosote materials, men working with and handling epoxy material or materials (where special protection is required), topper of standing trees, batter board man on pipe and ditch work, feeder man on wood pulverizers, board and willow mat weavers and cable tiers on river work, deck hands, pile dike and revetment work, all laborers working on underground tunnels less than 25 feet where compressed air is not used, abutment and pier hole men working six (6) feet or more below ground, men working in coffer dams for bridge piers and footings in the river, ditchliners, pressure groutmen, caulker and chain or concrete saw, cliffscalers working from scaffolds, bosuns' chairs or platforms on dams or power plants over (10) feet above ground, mortarmen on brick or block manholes, signal man.

GROUP 2: Skilled Laborer - spreader or screed man on asphalt machine, asphalt raker, grade checker, vibrator man, concrete saw over 5 hp., laser beam man, barco tamper, jackson or any other similar tamp, wagon driller, churn drills, air track drills and other similar drills, cutting torch man, form setters, liners and stringline men on concrete paving, curb, gutters and etc., hot mastic kettleman, hot tar applicator, hand blade operators, mortar men on brick or block manholes, sand blasting and gunnite nozzle men, rubbing concrete, air tool operator in tunnels, head pipe layer on sewer work, manhole builder (brick or block), dynamite and powder men.

 LAB00840-011 05/01/2023

Crawford, Dent, Franklin, Gasconade, Howell, Maries, Oregon, Osage, Phelps, Pulaski, Shannon and Texas Counties

	Rates	Fringes
LABORER (Crawford, Dent, Gasconade, Howell, Maries, Oregon, Osage, Phelps, Pulaski, Shannon and Texas Counties)		
GROUP 1.....	\$ 32.98	15.62
GROUP 2.....	\$ 32.98	15.62
LABORER (Franklin County)		

GROUP 1.....	\$ 35.44	15.62
GROUP 2.....	\$ 36.04	15.62

LABORERS CLASSIFICATIONS

GROUP 1 - General laborer-flagman, carpenter tenders; salamander Tenders; Dump Man; Ticket Takers; loading trucks under bins, hoppers, and conveyors; track man; cement handler; dump man on earth fill; georgie buggy man; material batch hopper man; spreader on asphalt machine; material mixer man (except on manholes); coffer dams; riprap pavers rock, block or brick; scaffolds over ten feet not self-supported from ground up; skip man on concrete paving; wire mesh setters on concrete paving; all work in connection with sewer, water, gas, gasoling, oil, drainage pipe, conduit pipe, tile and duct lines and all other pipe lines; power tool operator; all work in connection with hydraulic or general dredging operations; form setters, puddlers (paving only); straw blower nozzle man; asphalt plant platform man; chuck tender; crusher feeder; men handling creosote ties or creosote materials; men working with and handling epoxy material; topper of standing trees; feeder man on wood pulverizers, board and willow mat weavers and cabelee tiers on river work; deck hands; pile dike and revetment work; all laborers working on underground tunnels less than 25 ft. where compressed air is not used; abutment and pier hole men working six (6) ft. or more below ground; men working in coffer dams for bridge piers and footing in the river; barco tamper; jackson or any other similar tamp; cutting torch man; liners, curb, gutters, ditch lines; hot mastic kettlemen; hot tar applicator; hand blade operator; mortar men or brick or block manholes; rubbing concrete, air tool operator under 65 lbs.; caulker and lead man; chain or concrete saw under 15 h.p.; signal Gan; Guard rail and sign erectors.

GROUP 2 - Skilled laborers - Vibrator man; asphalt raker; head pipe layer on sewer work; batterboard man on pipe and ditch work; cliff scalers working from bosun's chairs; scaffolds or platforms on dams or power plants over 10 ft. high; air tool operator over 65 lbs.; stringline man on concrete paving; sandblast man; laser beam man; wagon drill; churn drill; air track drill and all other similar type drills, gunite nozzle man; pressure grout man; screed man on asphalt; concrete saw 15 h.p. and over; grade checker; strigline man on electronic grade control; manhole builder; dynamite man; powder man; welder; tunnel man; waterblaster - 1000 psi or over; asbestos and/or hazardous waste removal and/or disposal

LAB00955-012 05/01/2023

Adair, Audrain, Boone, Chariton, Cooper, Howard, Linn, Macon, Monroe, Putnam, Randolph, Schuyler and Sullivan Counties

	Rates	Fringes
LABORER		
GROUP 1.....	\$ 32.98	15.62
GROUP 2.....	\$ 32.98	15.62

LABORERS CLASSIFICATIONS

GROUP 1 - General laborer-flagman, carpenter tenders; salamander Tenders; Dump Man; Ticket Takers; loading trucks under bins, hoppers, and conveyors; track man; cement handler; dump man on earth fill; georgie buggy man; material batch hopper man; spreader on asphalt machine; material mixer man (except on manholes); coffer dams; riprap pavers rock, block or brick; scaffolds over ten feet not self-supported from ground up; skip man on concrete paving; wire mesh setters on concrete paving; all work in connection with sewer, water, gas, gasoling, oil, drainage pipe, conduit pipe, tile and duct lines and all other pipe lines; power tool operator; all work in connection with hydraulic or general dredging operations; form setters, puddlers (paving only); straw blower nozzle man; asphalt plant platform man; chuck tender; crusher feeder; men handling creosote ties or creosote materials; men working with and handling epoxy material; topper of standing trees; feeder man on wood pulverizers, board and willow mat weavers and cabelee tiers on river work; deck hands; pile dike and revetment work; all laborers working on underground tunnels less than 25 ft. where compressed air is not used; abutement and pier hole men working six (6) ft. or more below ground; men working in coffer dams for bridge piers and footing in the river; barco tamper; jackson or any other similar tamp; cutting torch man; liners, curb, gutters, ditch lines; hot mastic kettlemen; hot tar applicator; hand blade operator; mortar men or brick or block manholes; rubbing concrete, air tool operator under 65 lbs.; caulker and lead man; chain or concrete saw under 15 h.p.; signal Gan; Guard rail and sign erectors.

GROUP 2 - Skilled laborers - Vibrator man; asphalt raker; head pipe layer on sewer work; batterboard man on pipe and ditch work; cliff scalers working from bosun's chairs; scaffolds or platforms on dams or power plants over 10 ft. high; air tool operator over 65 lbs.; stringline man on concrete paving; sandblast man; laser beam man; wagon drill; churn drill; air track drill and all other similar type drills, gunite nozzle man; pressure grout man; screed man on asphalt; concrete saw 15 h.p. and over; grade checker; strigline man on electronic grade control; manhole builder; dynamite man; powder man; welder; tunnel man; waterblaster - 1000 psi or over; asbestos and/or hazardous waste removal and/or disposal

 LAB01104-005 05/01/2023

Bollinger, Butler, Cape Girardeau, Carter, Dunklin, Iron, Madison, Mississippi, New Madrid, Pemiscot, Perry, Reynolds, Ripley, Scott, St Francois, Ste Genevieve, Stoddard and Wayne Counties

	Rates	Fringes
LABORER		
GROUP 1.....	\$ 32.98	15.62
GROUP 2.....	\$ 32.98	15.62

LABORERS CLASSIFICATIONS

GROUP 1 - General laborer-flagman, carpenter tenders;

salamander Tenders; Dump Man; Ticket Takers; loading trucks under bins, hoppers, and conveyors; track man; cement handler; dump man on earth fill; georgie buggy man; material batch hopper man; spreader on asphalt machine; material mixer man (except on manholes); coffer dams; riprap pavers rock, block or brick; scaffolds over ten feet not self-supported from ground up; skip man on concrete paving; wire mesh setters on concrete paving; all work in connection with sewer, water, gas, gasoling, oil, drainage pipe, conduit pipe, tile and duct lines and all other pipe lines; power tool operator; all work in connection with hydraulic or general dredging operations; form setters, puddlers (paving only); straw blower nozzle man; asphalt plant platform man; chuck tender; crusher feeder; men handling creosote ties or creosote materials; men working with and handling epoxy material; topper of standing trees; feeder man on wood pulverizers, board and willow mat weavers and cable ties on river work; deck hands; pile dike and revetment work; all laborers working on underground tunnels less than 25 ft. where compressed air is not used; abutment and pier hole men working six (6) ft. or more below ground; men working in coffer dams for bridge piers and footing in the river; barco tamper; jackson or any other similar tamp; cutting torch man; liners, curb, gutters, ditch lines; hot mastic kettlemen; hot tar applicator; hand blade operator; mortar men or brick or block manholes; rubbing concrete, air tool operator under 65 lbs.; caulker and lead man; chain or concrete saw under 15 h.p.; signal Gan; Guard rail and sign erectors.

GROUP 2 - Skilled laborers - Vibrator man; asphalt raker; head pipe layer on sewer work; batterboard man on pipe and ditch work; cliff scalers working from bosun's chairs; scaffolds or platforms on dams or power plants over 10 ft. high; air tool operator over 65 lbs.; stringline man on concrete paving; sandblast man; laser beam man; wagon drill; churn drill; air track drill and all other similar type drills, gunite nozzle man; pressure grout man; screed man on asphalt; concrete saw 15 h.p. and over; grade checker; strigline man on electronic grade control; manhole builder; dynamite man; powder man; welder; tunnel man; waterblaster - 1000 psi or over; asbestos and/or hazardous waste removal and/or disposal

 PAIN002-002 09/01/2007

CLARK, FRANKLIN, JEFFERSON, LEWIS, LINCOLN, MARION, PIKE, RALLS, ST. CHARLES, ST. LOUIS (CITY & COUNTY), AND WARREN COUNTIES

	Rates	Fringes
Painters:		
Brush and Roller; Taper.....	\$ 28.61	10.24
High work over 60 feet.....	\$ 29.11	10.24
Lead Abatement.....	\$ 29.36	10.24
Pressure Roller; High work under 60 ft.....	\$ 28.86	10.24
Spray & Abrasive Blasting; Water Blasting (Over 5000 PSI).....	\$ 30.61	10.24
Taper (Ames Tools &		

Bazooka).....\$ 30.21 10.24

PAIN002-006 04/01/2023

ADAIR, AUDRAIN, BOONE, CALLAWAY, CHARITON, COLE, GASCONADE,
HOWARD, KNOX, LINN, MACON, MONROE, MONTGOMERY, OSAGE, PUTNAM,
RANDOLPH, SCHUYLER, SCOTLAND, SHELBY AND SULLIVAN COUNTIES and
the City of Booneville.

	Rates	Fringes
Painters:		
Bridges, Dams, Locks or Powerhouses.....	\$ 28.49	15.03
Brush and Roll; Taping, Paperhanging.....	\$ 26.49	15.03
Epoxy or Any Two Part Coating; Sandblasting; Stage or other Aerial Work - Platforms over 50 feet high; Lead Abatement.....	\$ 27.49	15.03
Spray; Structural Steel (over 50 feet).....	\$ 27.49	15.03
Tapers using Ames or Comparable Tools.....	\$ 27.24	15.03

PAIN003-004 04/01/2019

CASS, CLAY, CLINTON, JACKSON, JOHNSON, LAFAYETTE, PLATTE & RAY
COUNTIES

	Rates	Fringes
Painters:		
Bridgeman; Lead Abatement; Sandblast; Storage Bin & Tanks.....	\$ 33.41	17.76
Brush & Roller.....	\$ 30.54	17.76
Drywall.....	\$ 31.74	17.76
Paper Hanger.....	\$ 31.04	17.76
Stageman; Beltman; Steelman; Elevator Shaft; Bazooka, Boxes and Power Sander; Sprayman; Dipping...	\$ 32.41	17.76
Steeplejack.....	\$ 36.98	17.76

PAIN003-011 04/01/2019

BATES, BENTON, CALDWELL, CARROLL, COOPER, DAVIESS, GRUNDY,
HARRISON, HENRY, LIVINGSTON, MERCER, MONITEAU, MORGAN, PETTIS &
SALINE COUNTIES

	Rates	Fringes
Painters:		
Bridgeman; Lead Abatement; Sandblast; Storage Bin & Tanks.....	\$ 26.73	17.76
Brush & Roller.....	\$ 24.43	17.76
Drywall.....	\$ 25.39	17.76
Paper Hanger.....	\$ 24.83	17.76
Stageman; Beltman;		

Steelman; Elevator Shaft;		
Bazooka, Boxes and Power		
Sander; Sprayman; Dipping...	\$ 26.35	17.76
Steeplejack.....	\$ 29.58	17.76

PAIN0203-001 04/01/2012

BARRY, BARTON, CEDAR, CHRISTIAN, DADE, DALLAS, DOUGLAS, GREENE,
HICKORY, HOWELL, JASPER, LAWRENCE, MCDONALD, NEWTON, OZARK,
POLK, ST. CLAIR, STONE, TANEY, VERNON, WEBSTER, and WRIGHT
COUNTIES

	Rates	Fringes
Painters:		
Finisher.....	\$ 20.18	11.33
Painter.....	\$ 19.75	11.76
Sandblaster, High Man, Spray Man, Vinyl Hanger, Tool Operator.....	\$ 21.18	11.33

PAIN1185-008 04/01/2023

CAMDEN, CRAWFORD, DENT, LACLEDE, MARIES, MILLER, PHELPS,
PULASKI AND TEXAS COUNTIES

	Rates	Fringes
Painters:		
Brush and Roller.....	\$ 31.83	15.13
Floor Work.....	\$ 32.83	15.13
Lead Abatement.....	\$ 32.83	15.13
Spray.....	\$ 32.83	15.13
Structural Steel, Sandblasting and All Tank Work.....	\$ 33.83	15.13
Taping, Paperhanging.....	\$ 32.83	15.13

PAIN1292-002 09/01/2022

BOLLINGER, BUTLER, CAPE GIRARDEAU, CARTER, DUNKLIN,
MISSISSIPPI, NEW MADRID, OREGON, PEMISCOT, PERRY, REYNOLDS,
RIPLEY, SCOTT, SHANNON, STODDARD and WAYNE COUNTIES

	Rates	Fringes
Painters:		
Bridges, Stacks & Tanks.....	\$ 33.93	15.36
Brush & Roller.....	\$ 29.58	15.36
Spray & Abrasive Blasting; Waterblasting (over 5000 PSI).....	\$ 31.58	15.36

Height Rates (All Areas):
Over 60 ft. \$0.50 per hour.
Under 60 ft. \$0.25 per hour.

PAIN1292-003 09/01/2022

IRON, MADISON, ST. FRANCOIS, STE. GENEVIEVE and WASHINGTON
COUNTIES

	Rates	Fringes
Painters:		
Bridges, Stacks & Tanks.....	\$ 33.93	15.36
Brush & Roller.....	\$ 29.58	15.36
Spray & Abrasive Blasting; Waterblasting (Over 5000 PSI).....	\$ 31.58	15.36

Height Rates (All Areas):
Over 60 ft. \$0.50 per hour
Under 60 ft. \$0.25 per hour.

PAIN2012-001 04/20/2022

ANDREW, ATCHISON, BUCHANAN, DE KALB, GENTRY, HOLT, NODAWAY &
WORTH COUNTIES

	Rates	Fringes
Painters:		
Brush & Roller.....	\$ 33.35	18.73
Sandblaster.....	\$ 37.27	18.73
Steeplejack.....	\$ 40.84	18.73

PLAS0518-006 03/01/2023

BARRY, BARTON, CEDAR, CHRISTIAN, DADE, DALLAS, DOUGLAS, GREENE,
HICKORY, JASPER, LACLEDE, LAWRENCE, MCDONALD, NEWTON, OZARK,
POLK, ST. CLAIR, STONE, TANEY, VERNON, WEBSTER, AND WRIGHT
COUNTIES

	Rates	Fringes
CEMENT MASON/CONCRETE FINISHER...	\$ 26.57	12.43

PLAS0518-007 04/01/2023

CASS (Richards-Gebaur AFB only), CLAY, JACKSON, PLATTE AND RAY
COUNTIES

	Rates	Fringes
Cement Masons:.....	\$ 36.57	18.30

PLAS0518-011 04/01/2023

ANDREW, ATCHISON, BATES, BUCHANNAN, CLINTON, DEKALB, GENTRY,
HENRY, HOLT, JOHNSON, LAFAYETTE, NODAWAY & WORTH COUNTIES

	Rates	Fringes
CEMENT MASON/CONCRETE FINISHER...	\$ 36.03	20.50

PLAS0527-001 04/01/2021

Rates	Fringes
-------	---------

CEMENT MASON

FRANKLIN, LINCOLN AND WARREN COUNTIES.....	\$ 34.79	19.58
JEFFERSON, ST. CHARLES COUNTIES AND ST. LOUIS (City and County).....	\$ 35.96	19.56

PLAS0527-004 06/01/2021

CRAWFORD, DENT, IRON, MADISON, MARION, PHELPS, PIKE, PULASKI,
RALLS, REYNOLDS, ST. FRANCOIS, STE. GENEVIEVE, SHANNON, TEXAS,
WASHINGTON COUNTIES

	Rates	Fringes
CEMENT MASON.....	\$ 30.30	19.48

* PLAS0908-001 05/01/2023

BOLLINGER, BUTLER, CAPE GIRARDEAU, CARTER, DUNKLIN, HOWELL,
MISSISSIPPI, NEW MADRID, OREGON, PEMISCOT, PERRY, RIPLEY,
SCOTT, STODDARD, AND WAYNE COUNTIES

	Rates	Fringes
CEMENT MASON.....	\$ 32.30	18.38

* PLAS0908-005 05/01/2023

BENTON, CALDWELL, CALLAWAY, CAMDEN, CARROLL, COLE, DAVIESS,
GASCONADE, GRUNDY, HARRISON, LIVINGSTON, MACON, MARIES, MERCER,
MILLER, MONTGOMERY, MORGAN, OSAGE, PETTIS & SALINE COUNTIES

	Rates	Fringes
CEMENT MASON.....	\$ 32.30	18.38

PLUM0008-003 06/01/2023

CASS, CLAY, JACKSON, JOHNSON, AND PLATTE COUNTIES

	Rates	Fringes
Plumbers.....	\$ 54.28	23.79

PLUM0008-017 06/01/2023

BATES, BENTON, CARROLL, HENRY, LAFAYETTE, MORGAN, PETTIS, RAY,
ST. CLAIR, SALINE AND VERNON COUNTIES

	Rates	Fringes
Plumbers.....	\$ 54.28	23.79

PLUM0045-003 08/01/2022

ANDREW, ATCHISON, BUCHANAN, CALDWELL, CLINTON, DAVIESS, DEKALB,
GENTRY, HARRISON, HOLT, NODAWAY AND WORTH COUNTIES

Rates Fringes

Plumbers and Pipefitters.....\$ 41.35 25.45

PLUM0178-003 11/01/2022

BARRY, CEDAR, CHRISTIAN, DADE, DALLAS, DOUGLAS, GREENE,
HICKORY, LACLEDE, LAWRENCE, POLK, STONE, TANEY, WEBSTER AND
WRIGHT COUNTIES

	Rates	Fringes
Plumbers and Pipefitters.....	\$ 35.75	15.32

PLUM0178-006 11/01/2022

BARTON, JASPER, MCDONALD AND NEWTON COUNTIES

	Rates	Fringes
Plumbers and Pipefitters		
Projects \$750,000 & under....	\$ 32.78	15.32
Projects over \$750,000.....	\$ 35.75	15.32

PLUM0533-004 06/01/2023

BATES, BENTON, CARROLL, CASS, CLAY, HENRY, HICKORY, JACKSON,
JOHNSON, LAFAYETTE, MORGAN, PETTIS, PLATTE, RAY, SALINE, ST.
CLAIR AND VERNON COUNTIES

	Rates	Fringes
Pipefitters.....	\$ 53.56	24.70

* PLUM0562-004 07/01/2023

ADAIR, AUDRAIN, BOLLINGER, BOONE, BUTLER, CALLAWAY, CAMDEN, CAPE
GIRARDEAU, CARTER, CHARITON, CLARK, COLE, COOPER, CRAWFORD,
DENT, DUNKLIN, FRANKLIN, GASCONADE, GRUNDY, HOWARD, HOWELL,
IRON, JEFFERSON, KNOX, LEWIS, LINCOLN, LINN, LIVINGSTON, MACON,
MADISON, MARIES, MARION, MERCER, MILLER, MISSISSIPPI, MONITEAU,
MONROE, MONTGOMERY, NEW MADRID, OREGON, OSAGE, PEMISCOTT,
PERRY, PHELPS, PIKE, PULASKI, PUTNAM, RALLS, RANDOLPH,
REYNOLDS, RIPLEY, ST. CHARLES, ST. FRANCOIS, STE. GENEVIEVE, ST.
LOUIS, SCHUYLER, SCOTLAND, SCOTT, SHANNON, SHELBY, STODDARD,
SULLIVAN, TEXAS, WARREN, WASHINGTON, AND WAYNE COUNTIES.

	Rates	Fringes
Plumbers and Pipefitters		
Mechanical Contracts		
including all piping and		
temperature control work		
\$7.0 million & under.....	\$ 46.66	21.99
Mechanical Contracts		
including all piping and		
temperature control work		
over \$7.0 million.....	\$ 46.66	21.99

* PLUM0562-016 07/01/2023

CAMDEN, COLE, CRAWFORD, FRANKLIN, JEFFERSON, MARIES, MILLER,
MONITEAU, OSAGE, PHELPS, PULASKI, ST. CHARLES, ST. LOUIS (City

and County), WARREN and WASHINGTON COUNTIES

	Rates	Fringes
Plumbers		
Mechanical Contracts including all piping and temperature control work \$7.0 million & under.....	\$ 46.66	21.99
Mechanical Contracts including all piping and temperature control work over \$7.0 million.....	\$ 46.66	21.99

TEAM0013-001 05/01/2023		

	Rates	Fringes
Truck drivers (ADAIR, BUTLER, CLARK, DUNKIN, HOWELL, KNOX, LEWIS, OREGON, PUTNAM, RIPLEY, SCHUYLER AND SCOTLAND COUNTIES)		
GROUP 1.....	\$ 33.04	15.15
GROUP 2.....	\$ 33.19	15.15
GROUP 3.....	\$ 33.31	15.15
GROUP 4.....	\$ 33.20	15.15
Truck drivers (AUDRAIN, BOLLINGER, BOONE, CALLAWAY, CAPE GIRARDEAU, CARTER, COLE, CRAWFORD, DENT, GASCONADE, IRON, MACON, MADISON, MARIES, MARION, MILLER, MISSISSIPPI, MONROE, MONTGOMERY, NEW MADRID, OSAGE, PEMISCOT, PERRY, PHELPS, PIKE, PULASKI, RALLS, REYNOLDS, ST. FRANCOIS, STE. GENEVIEVE, SCOTT, SHANNON, SHELBY, STODDARD, TEXAS, WASHINGTON AND WAYNE COUNTIES)		
GROUP 1.....	\$ 33.77	15.05
GROUP 2.....	\$ 33.93	15.05
GROUP 3.....	\$ 33.92	15.05
GROUP 4.....	\$ 34.04	15.05
Truck drivers (FRANKLIN, JEFFERSON and ST. CHARLES COUNTIES)		
GROUP 1.....	\$ 36.13	15.15
GROUP 2.....	\$ 36.24	15.15
GROUP 3.....	\$ 36.28	15.15
GROUP 4.....	\$ 36.35	15.15
Truck drivers (LINCOLN and WARREN COUNTIES)		
GROUP 1.....	\$ 34.78	15.15
GROUP 2.....	\$ 34.89	15.15
GROUP 3.....	\$ 35.93	15.15
GROUP 4.....	\$ 35.00	15.15

TRUCK DRIVERS CLASSIFICATIONS:

GROUP 1: Flat Bed Trucks, Single Axle; Station Wagons;
Pickup Trucks; Material Trucks, Single Axle; Tank Wagon,
Single Axle

GROUP 2: Agitator and Transit Mix Trucks

GROUP 3: Flat Bed Trucks, Tandem Axle; Articulated Dump Trucks; Material Trucks, Tandem Axle; Tank Wagon, Tandem Axle

GROUP 4: Semi and/or Pole Trailers; Winch, Fork & Steel Trucks; Distributor Drivers and Operators; Tank Wagon, Semi-Trailer; Insley Wagons, Dumpsters, Half-Tracks, Speedace, Euclids and other similar equipment; A-Frame and Derrick Trucks; Float or Low Boy

TEAM0056-001 05/01/2020

	Rates	Fringes
Truck drivers (ANDREW, BARTON, BATES, BENTON, CALDWELL, CAMDEN, CARROLL, CEDAR, CHARITON, CHRISTIAN, CLINTON, COOPER, DADE, DALLAS, DAVIESS, DEKALB, DOUGLAS, GREENE, HENRY, HICKORY, HOWARD, JASPER, LACLEDE, LAWRENCE, LINN, LIVINGSTON, MONITEAU, MORGAN, NEWTON, PETTIS, POLK, RANDOLPH, ST. CLAIR, SALINE, VERNON, WEBSTER AND WRIGHT COUNTIES)		
GROUP 1.....	\$ 31.37	14.25
GROUP 2.....	\$ 31.53	14.25
GROUP 3.....	\$ 31.52	14.25
GROUP 4.....	\$ 31.64	14.25
Truck drivers: (ATCHISON, BARRY, GENTRY, GRUNDY, HARRISON, HOLT, MCDONALD, MERCER, NODAWAY, OZARK, STONE, SULLIVAN, TANEY AND WORTH COUNTIES)		
GROUP 1.....	\$ 30.64	14.25
GROUP 2.....	\$ 30.80	14.25
GROUP 3.....	\$ 30.79	14.25
GROUP 4.....	\$ 30.91	14.25
Truck drivers; (BUCHANAN, JOHNSON AND LAFAYETTE COUNTIES)		
GROUP 1.....	\$ 32.58	14.25
GROUP 2.....	\$ 32.69	14.25
GROUP 3.....	\$ 32.73	14.25
GROUP 4.....	\$ 32.80	14.25

TRUCK DRIVER CLASSIFICATIONS

GROUP 1: Flat bed trucks single axle; station wagons; pickup trucks; material trucks single axle; tank wagons single axle.

GROUP 2: Agitator and transit mix-trucks.

GROUP 3: Flat bed trucks tandem axle; articulated dump trucks; material trucks tandem axle; tank wagons tandem axle.

GROUP 4: Semi and/or pole trailers; winch, fork & steel trucks; distributor drivers & operators; tank wagons semi-trailer; insley wagons, dumpsters, half-tracks, speedace, euclids & other similar equipment; A-frames and derrick trucks; float or low boy.

 TEAM0245-001 03/26/2012

BARRY, BARTON, CAMDEN, CEDAR, CHRISTIAN, DALLAS, DENT, DOUGLAS, GREENE, HICKORY, HOWELL, JASPER, LACLEDE, LAWRENCE, MCDONALD, MILLER, NEWTON, OZARK, PHELPS, POLK, PULASKI, SHANNON, STONE, TANEY, TEXAS, VERNON, WEBSTER AND WRIGHT COUNTIES

	Rates	Fringes
Truck drivers:		
Traffic Control Service		
Driver.....	\$ 20.45	0.00

PAID HOLIDAYS: New Year's Day, Decoration Day, July 4th, Labor Day, Thanksgiving Day, Christmas Day, employee's birthday and 2 personal days.

 TEAM0541-001 04/01/2023

CASS, CLAY, JACKSON, PLATTE AND RAY COUNTIES

	Rates	Fringes
Truck drivers:		
GROUP 1.....	\$ 35.31	17.55
GROUP 2.....	\$ 34.74	17.55
GROUP 3.....	\$ 34.22	17.55

TRUCK DRIVERS CLASSIFICATIONS

GROUP 1: Mechanics and Welders, Field; A-Frame Low Boy-Boom ruck Driver.

GROUP 2: Articulated Dump Truck; Insley Wagons: Dump Trucks, Excavating, 5 cu yds and over; Dumpsters; Half-Tracks: Speedace: Euclids & similar excavating equipment Material trucks, Tandem Two teams; Semi-Trailers; Winch trucks-Fork trucks; Distributor Drivers and Operators; Agitator and Transit Mix; Tank Wagon Drivers, Tandem or Semi; One Team; Station Wagons; Pickup Trucks; Material Trucks, Single Axle; Tank Wagon Drivers, Single Axle

GROUP 3: Oilers and Greasers - Field

 TEAM0682-002 05/01/2023

ST LOUIS CITY AND COUNTY

	Rates	Fringes
Truck drivers:		
GROUP 1.....	\$ 34.37	8.44+a+b+c+d
GROUP 2.....	\$ 34.37	8.44+a+b+c+d
GROUP 3.....	\$ 34.37	8.44+a+b+c+d

a. PENSION: 5/1/2012 - \$182.20 per week.

b. HAZMAT PREMIUM: If Hazmat certification on a job site is required by a state or federal agency or requested by project owner or by the employer, employees on that job site shall receive \$1.50 premium pay.

TRUCK DRIVERS CLASSIFICATIONS

GROUP 1 - Pick-up trucks; forklift, single axle; flatbed trucks; job site ambulance, and trucks or trailers of a water level capacity of 11.99 cu. yds. or less

GROUP 2 - Trucks or trailers of a water level capacity of 12.0 cu yds. up to 22.0 cu yds. including euclids, speedace and similar equipment of same capacity and compressors

GROUP 3 - Trucks or trailers of a water level capacity of 22.0 cu. yds & over including euclids, speedace & all floats, flatbed trailers, boom trucks, winch trucks, including small trailers, farm wagons tilt-top trailers, field offices, tool trailers, concrete pumps, concrete conveyors & gasoline tank trailers and truck mounted mobile concrete mixers

FOOTNOTE FOR TRUCK DRIVERS:

c. PAID HOLIDAYS: Christmas Day, Independence Day, Labor Day, Memorial Day, Veterans Day, New Years Day, Thanksgiving Day

d. PAID VACATION: 3 days paid vacation for 600 hours of service in any one contract year; 4 days paid vacation for 800 hours of service in any one contract year; 5 days paid vacation for 1,000 hours of service in any one contract year. When such an employee has completed 3 years of continuous employment with the same employer and then works the above required number of hours, he shall receive double the number of days of vacation specified above. When such an employee has completed 10 years of continuous employment with the same employer and then works the above required number of hours, he shall receive triple the number of days of vacation specified above. When such an employee has completed 15 years of continuous employment with the same employer and then works the above required number of hours, he shall receive 4 times the number of days of vacation specified above.

WELDERS - Receive rate prescribed for craft performing operation to which welding is incidental.

=====
Note: Executive Order (EO) 13706, Establishing Paid Sick Leave for Federal Contractors applies to all contracts subject to the Davis-Bacon Act for which the contract is awarded (and any solicitation was issued) on or after January 1, 2017. If this contract is covered by the EO, the contractor must provide employees with 1 hour of paid sick leave for every 30 hours they work, up to 56 hours of paid sick leave each year. Employees must be permitted to use paid sick leave for their own illness, injury or other health-related needs, including

preventive care; to assist a family member (or person who is like family to the employee) who is ill, injured, or has other health-related needs, including preventive care; or for reasons resulting from, or to assist a family member (or person who is like family to the employee) who is a victim of, domestic violence, sexual assault, or stalking. Additional information on contractor requirements and worker protections under the EO is available at <https://www.dol.gov/agencies/whd/government-contracts>.

Unlisted classifications needed for work not included within the scope of the classifications listed may be added after award only as provided in the labor standards contract clauses (29CFR 5.5 (a) (1) (ii)).

The body of each wage determination lists the classification and wage rates that have been found to be prevailing for the cited type(s) of construction in the area covered by the wage determination. The classifications are listed in alphabetical order of ""identifiers"" that indicate whether the particular rate is a union rate (current union negotiated rate for local), a survey rate (weighted average rate) or a union average rate (weighted union average rate).

Union Rate Identifiers

A four letter classification abbreviation identifier enclosed in dotted lines beginning with characters other than ""SU"" or ""UAVG"" denotes that the union classification and rate were prevailing for that classification in the survey. Example: PLUM0198-005 07/01/2014. PLUM is an abbreviation identifier of the union which prevailed in the survey for this classification, which in this example would be Plumbers. 0198 indicates the local union number or district council number where applicable, i.e., Plumbers Local 0198. The next number, 005 in the example, is an internal number used in processing the wage determination. 07/01/2014 is the effective date of the most current negotiated rate, which in this example is July 1, 2014.

Union prevailing wage rates are updated to reflect all rate changes in the collective bargaining agreement (CBA) governing this classification and rate.

Survey Rate Identifiers

Classifications listed under the ""SU"" identifier indicate that no one rate prevailed for this classification in the survey and the published rate is derived by computing a weighted average rate based on all the rates reported in the survey for that classification. As this weighted average rate includes all rates reported in the survey, it may include both union and non-union rates. Example: SULA2012-007 5/13/2014. SU indicates the rates are survey rates based on a weighted average calculation of rates and are not majority rates. LA indicates the State of Louisiana. 2012 is the year of survey on which these classifications and rates are based. The next number, 007 in the example, is an internal number used in producing the wage determination. 5/13/2014 indicates the survey completion date for the classifications and rates under that identifier.

Survey wage rates are not updated and remain in effect until a new survey is conducted.

Union Average Rate Identifiers

Classification(s) listed under the UAVG identifier indicate that no single majority rate prevailed for those classifications; however, 100% of the data reported for the classifications was union data. EXAMPLE: UAVG-OH-0010 08/29/2014. UAVG indicates that the rate is a weighted union average rate. OH indicates the state. The next number, 0010 in the example, is an internal number used in producing the wage determination. 08/29/2014 indicates the survey completion date for the classifications and rates under that identifier.

A UAVG rate will be updated once a year, usually in January of each year, to reflect a weighted average of the current negotiated/CBA rate of the union locals from which the rate is based.

WAGE DETERMINATION APPEALS PROCESS

1.) Has there been an initial decision in the matter? This can be:

- * an existing published wage determination
- * a survey underlying a wage determination
- * a Wage and Hour Division letter setting forth a position on a wage determination matter
- * a conformance (additional classification and rate) ruling

On survey related matters, initial contact, including requests for summaries of surveys, should be with the Wage and Hour National Office because National Office has responsibility for the Davis-Bacon survey program. If the response from this initial contact is not satisfactory, then the process described in 2.) and 3.) should be followed.

With regard to any other matter not yet ripe for the formal process described here, initial contact should be with the Branch of Construction Wage Determinations. Write to:

Branch of Construction Wage Determinations
Wage and Hour Division
U.S. Department of Labor
200 Constitution Avenue, N.W.
Washington, DC 20210

2.) If the answer to the question in 1.) is yes, then an interested party (those affected by the action) can request review and reconsideration from the Wage and Hour Administrator (See 29 CFR Part 1.8 and 29 CFR Part 7). Write to:

Wage and Hour Administrator
U.S. Department of Labor
200 Constitution Avenue, N.W.
Washington, DC 20210

The request should be accompanied by a full statement of the interested party's position and by any information (wage payment data, project description, area practice material,

etc.) that the requestor considers relevant to the issue.

3.) If the decision of the Administrator is not favorable, an interested party may appeal directly to the Administrative Review Board (formerly the Wage Appeals Board). Write to:

Administrative Review Board
U.S. Department of Labor
200 Constitution Avenue, N.W.
Washington, DC 20210

4.) All decisions by the Administrative Review Board are final.

=====

END OF GENERAL DECISIO"

ENVIRONMENTAL PERMITS





ADA CHECKLIST

Revised December 22, 2022

Job No. _____ Route _____ County _____ Location _____

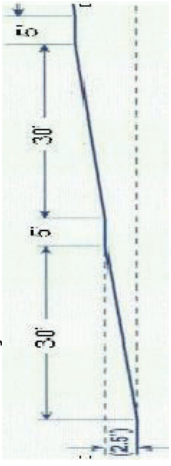
Pedestrian Access Route (PROWAG R204)		YES	NO	NA
<p>Figures/Examples</p> <p>Sidewalk Width</p> 	<p>Requirements</p> <ul style="list-style-type: none"> The minimum continuous and unobstructed clear width of a pedestrian access route shall be 4.0 feet, exclusive of the width of the curb. The continuous clear width of pedestrian access routes for medians and pedestrian refuge islands must be 5 feet minimum in order to allow for passing space. MoDOT Sidewalks shall be 5 feet wide minimum.² MoDOT Sidewalks located within 2 feet of the back of curb are to be constructed 6 feet wide minimum and constructed adjacent to the back of the curb.² Exception: an unaltered, existing sidewalk shall be 3 feet wide minimum and shall provide 5 foot x 5 foot passing spaces at intervals of 200 feet maximum.² Detectable warning surfaces shall be provided, where a curb ramp, landing, or blended transition connects to a street. Where commercial driveways are provided with traffic control devices or otherwise are permitted to operate like public streets, detectable warnings should be provided at the junction between the pedestrian route and the street. Gratings, access covers, and other appurtenances shall not be located on curb ramps, landings, blended transitions, and gutters within the pedestrian access route. Grade breaks shall not be permitted on the surface of curb ramps, blended transitions, landings, and gutter areas within the pedestrian access route. Surface slopes that meet at grade breaks shall be flush. 			
<p>Passing Spaces</p>	<ul style="list-style-type: none"> Walkways in pedestrian access routes that are less than 5 feet in clear width shall provide passing spaces at intervals of 200 feet maximum. Pedestrian access routes at passing spaces shall be 5 feet wide for a distance of 5 feet. 			
<p>Sidewalk Running Slope</p> <p>The grade that is parallel to the direction of travel, expressed as a ratio of rise to run or as a percent.</p>	<ul style="list-style-type: none"> The running slope of a pedestrian access route shall be 5 percent maximum. <p>Roadway Grade Exception: Where pedestrian access routes are contained within a street or highway right-of-way, the grade of the pedestrian access route is permitted to equal the general grade established for the adjacent street or highway. <ul style="list-style-type: none"> Running Slopes shall be measured using a calibrated 2 foot long digital level. </p>			

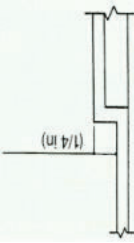
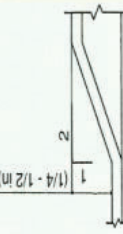
Figures/Examples	Requirements ¹	YES	NO	NA
<p>Sidewalk Cross Slope The grade that is perpendicular to the direction of accessible pedestrian travel, measured perpendicular to the curb line or edge of the street or highway, or measured perpendicular to the running grade.</p> <p>Sidewalk Ramps For example, a ramp segment with the maximum allowed running slope of 8.33% would require 5' x 5' landing after every 30' of run.</p> 	<ul style="list-style-type: none"> The cross slope of the walkway of a pedestrian access route shall be 2 percent maximum. (Roadway Grade Exception may be considered) 2010 ADA/ABA allows for cross slopes of up to 1/4 inch per foot (2.08 percent). In either case, a cross slope measurement of 2.1 percent or greater is not ADA compliant. Cross Slopes shall be measured using a calibrated 2 foot long digital level. A sidewalk segment (not contained within a street or highway border) with a running grade in excess of 5 percent but less than 8.33 percent is by definition a sidewalk ramp. The clear width of landings, blended transitions, and curb ramps, excluding flares, shall be 4.0 feet minimum. Cross slope of ramp runs shall be 2 percent maximum. The rise for any ramp run shall be 30 inches maximum. Ramps shall have landings at the top and the bottom of each ramp run. Ramp runs with a rise greater than 6 inches shall have handrails. Handrails shall be provided on both sides of stairs and ramps. Edge protection shall be provided on each side of ramp runs. Detectable warning surfaces shall be provided, where a curb ramp, landing, or blended transition connects to a street. Gratings, access covers, and other appurtenances shall not be located on ramps, landings, blended transitions, and gutters within the pedestrian access route. Grade breaks shall not be permitted on the surface of ramps, blended transitions, landings, and gutter areas within the pedestrian access route. Surface slopes that meet at grade breaks shall be flush. 			

Figures/Examples	Requirements ¹	YES	NO	NA
<p data-bbox="136 1745 168 2007">Vertical Alignment</p>   	<ul data-bbox="136 390 821 1514" style="list-style-type: none"> Vertical alignment shall be planar within curb ramp runs, blended transitions, landings, and gutter areas within the pedestrian access route, and within clear spaces required for accessible pedestrian signals, street furniture, and operable parts. Grade breaks shall not be permitted on the surface of curb ramps, blended transitions, landings, and gutter areas within the pedestrian access route. Grade breaks shall be flush. Running Slopes and Cross Slopes shall be measured using a calibrated 2 foot long digital level. Where the pedestrian access route crosses rail tracks at grade, the surface of the pedestrian access route shall be level and flush with the top of the rail at the outer edges of the rail. The surface between the rails shall be aligned with the top of the rail. Changes in level at grade breaks shall be flush. Changes in level of 1/4 inch high maximum shall be permitted to be vertical. Changes in level between 1/4 inch high maximum and 1/2 inch high maximum shall be beveled with a slope not steeper than 1v:2h. The bevel shall be applied across the entire level change. Changes in level greater than 1/2 inch high shall be ramp grade or flatter, a slope of 8.33 percent or less. 			

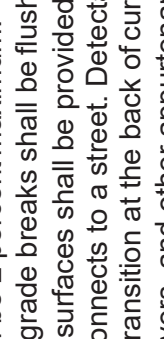
Figures/Examples	Requirements ¹	YES	NO	NA
<p>Landing A required level space required at both ends of a ramp. An area 5' x 5' with no slope greater than 2 percent. This space can be used as a place to rest, turn or pass another user.</p> <p>Landings that are contained within a street or highway border are permitted to use the Roadway Grade Exception for running slopes or cross slopes in the direction of the roadway travel being matched.</p> 	<ul style="list-style-type: none"> The landing clear width shall be at least as wide as the widest ramp run leading to the landing. The clear width of landings, blended transitions, and curb ramps, excluding flares, shall be 4 feet minimum. The landing clear length shall be 5 feet long minimum. Landing slopes shall be 2 percent maximum. Changes in level at grade breaks shall be flush. Detectable warning surfaces shall be provided, where a curb ramp, landing, or blended transition connects to a street. Detectable warning shall be located on the landing or blended transition at the back of curb. Gratings, access covers, and other appurtenances shall not be located on curb ramps, landings, blended transitions, and gutters within the pedestrian access route. Grade breaks shall not be permitted on the surface of curb ramps, blended transitions, landings, and gutter areas within the pedestrian access route. Surface slopes that meet at grade breaks shall be flush. <p>Roadway Grade Exception: The grade of pedestrian access routes within sidewalks is permitted to equal the general grade established for the adjacent street or highway. The cross slope of curb ramps, blended transitions, landings, and turning spaces at pedestrian street crossings without yield or stop control where vehicles can proceed through the intersection without slowing or stopping, and at midblock pedestrian street crossings are permitted to equal the street or highway grade.</p> <ul style="list-style-type: none"> Running Slopes and Cross Slopes shall be measured using a calibrated 2 foot long digital level. 			

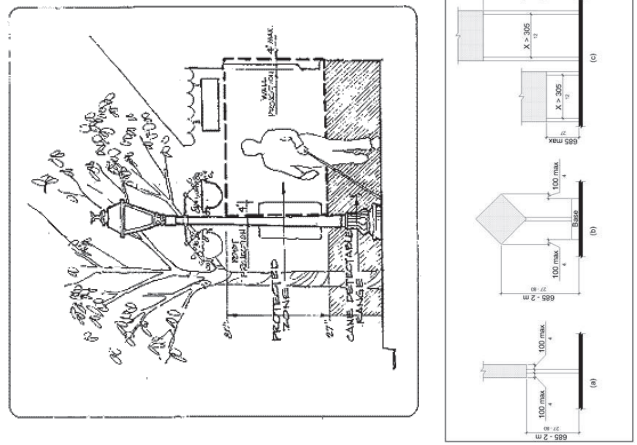
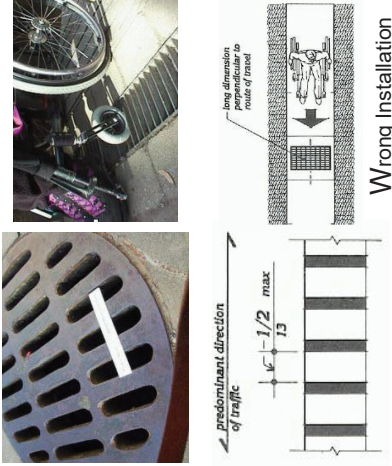
Figures/Examples	Requirements ¹	YES	NO	NA
	<ul style="list-style-type: none"> Protruding objects on sidewalks and other pedestrian circulation paths shall not reduce the clear width required for pedestrian accessible routes. Objects with leading edges more than 27 inches and not more than 80 inches above the finish floor or ground shall protrude 4 inches maximum horizontally into the circulation path. Free-standing objects mounted on posts or pylons shall overhang circulation paths 4 inches maximum measured horizontally from the post or pylon base when located 27 inches minimum and 80 inches maximum above the finish floor or ground. The base dimension shall be 2.5 inches thick minimum. (2011 PROWAG R402.3) Where a sign or other obstruction is mounted between posts or pylons and the clear distance between the posts or pylons is greater than 12 inches, the lowest edge of such sign or obstruction shall be 27 inches maximum or 80 inches minimum above the finish floor or ground. Vertical clearance shall be 80 inches high minimum. Guardrails or other barriers shall be provided where the vertical clearance is less than 80 inches high. The leading edge of such guardrail or barrier shall be located 27 inches maximum above the finish floor or ground. Guardrails or other barriers shall be provided where the vertical clearance is less than 80 inches high. The leading edge of such guardrail or barrier shall be located 27 inches maximum above the finish surface or ground. Openings in floor and ground surfaces shall not allow passage of a sphere more than 1/2 inch diameter. Elongated openings shall be placed so that the long dimension is perpendicular to the dominant direction of travel. Gratings, access covers, and other appurtenances shall not be located on curb ramps, landings, blended transitions, and gutters within the pedestrian access route. Lift holes for manhole/utility covers shall not have an opening greater than 1/2 inch. Plugging of holes greater than 1/2 inch with a material approved by the engineer is acceptable as long as it complies with the changes in level requirements. 			
				

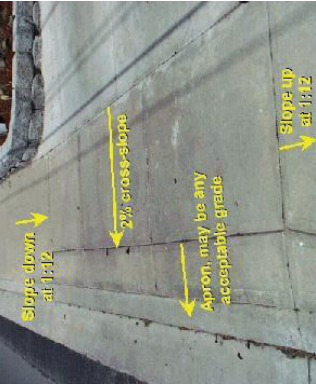
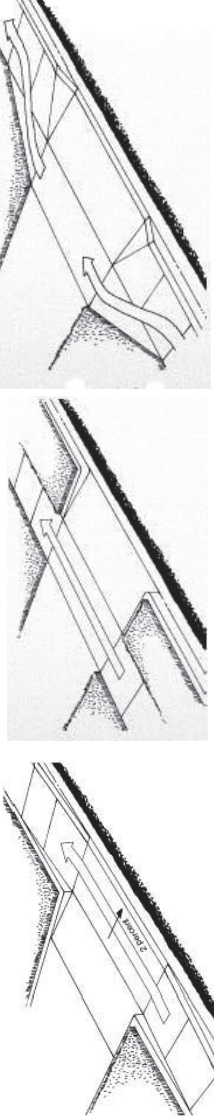
ENTRANCES (PROWAG R301)				
Requirements ¹		YES	NO	NA
<p>Figures/Examples</p> 	<ul style="list-style-type: none"> The minimum continuous and unobstructed clear width of a pedestrian access route provided across commercial and residential entrances shall be 4 feet minimum. Cross slope shall be 2 percent maximum. Be cautious with the transition from the driveway to the roadway to avoid grade combinations that will cause vehicles to bottom out when driving over the transition. ² 			

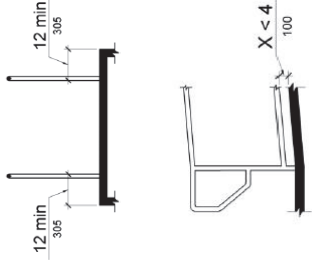
EDGE PROTECTION (PROWAG R406.8)				
Requirements ¹		YES	NO	NA
<p>Figures/Examples</p> 	<ul style="list-style-type: none"> Edge protection shall be provided on each side of ramp runs and at each side of ramp landings. A curb or barrier shall be provided that prevents the passage of a 4 inch diameter sphere, where any portion of the sphere is within 4 inches of the finish floor or ground surface. Edge-protection shall not be required when the floor or ground surface of the ramp run or landing extends 12 inches minimum beyond the inside face of a handrail. Edge protection shall not be required on curb ramps and their landings. Edge protection shall not be required on ramps that are not required to have handrails and have flares not steeper than 1:10. Edge protection shall not be required on the sides of ramp landings having a vertical drop-off of 1/2 inch maximum within 10 inches horizontally of the minimum landing area. 			

HANDRAIL AND PEDESTRIAN GUARDRAIL (PROWAG R408)

Requirements¹

Figures/Examples

- The clear width of walking surfaces shall be 4.0 feet minimum.
- Handrails are required on ramp runs with a rise greater than 6 inches and on certain stairways. Handrails are not required on walking surfaces with running slopes less than 1:20. Where required, handrails shall be provided on both sides of stairs and ramps.
- Handrails shall be continuous within the full length of each stair flight or ramp run. Inside handrails on switchback or dogleg stairs and ramps shall be continuous between flights or runs.
- Top of gripping surfaces of handrails shall be 34 inches minimum and 38 inches maximum vertically above walking surfaces, stair nosings, and ramp surfaces. Handrails shall be at a consistent height above walking surfaces, stair nosings, and ramp surfaces.
- Clearance between handrail gripping surfaces and adjacent surfaces shall be 1 1/2 inches minimum.
- Handrail gripping surfaces with a circular cross section shall have an outside diameter of 1 1/4 inches minimum and 2 inches maximum.
- Handrail gripping surfaces with a non-circular cross section shall have a perimeter dimension of 4 inches minimum and 6 1/4 inches maximum, and a cross-section dimension of 2 1/4 inches maximum.
- Handrail gripping surfaces and any surfaces adjacent to them shall be free of sharp or abrasive elements and shall have rounded edges.
- Handrails shall not rotate within their fittings.
- Ramp handrails shall extend horizontally above the landing for 12 inches minimum beyond the top and bottom of ramp runs. Extensions shall return to a wall, guard, or the landing surface, or shall be continuous to the handrail of an adjacent ramp run.
- At the top of a stair flight, handrails shall extend horizontally above the landing for 12 inches minimum beginning directly above the first riser nosing. Extensions shall return to a wall, guard, or the landing surface, or shall be continuous to the handrail of an adjacent stair flight.
- At the bottom of a stair flight, handrails shall extend at the slope of the stair flight for a horizontal distance at least equal to one tread depth beyond the last riser nosing. Extension shall return to a wall, guard, or the landing surface, or shall be continuous to the handrail of an adjacent stair flight.
- See Edge Protection section above (also PROWAG 406.8) for additional details.

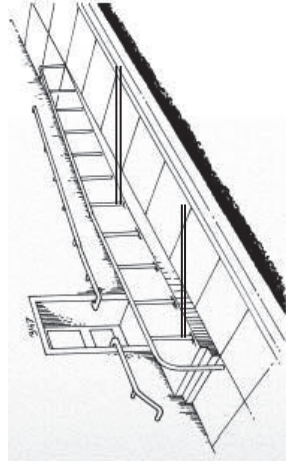
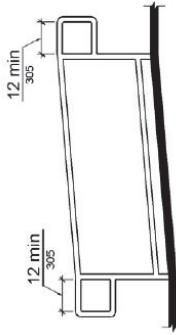
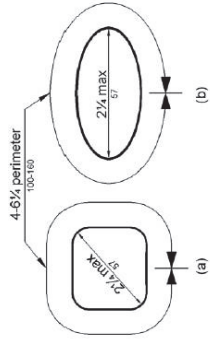
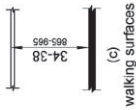
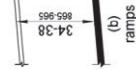
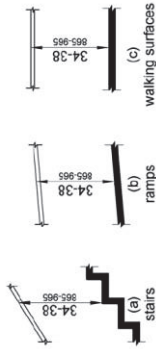

STAIRWAYS (PROWAG R407)

Requirements¹

- All steps on a flight of stairs shall have uniform riser heights and uniform tread depths. Risers shall be 4 inches high minimum and 7 inches high maximum. Treads shall be 11 inches deep minimum.
- Open risers are not permitted.
- The radius of curvature at the leading edge of the tread shall be 1/2 inch maximum. Nosings that project beyond risers shall have the underside of the leading edge curved or beveled. Risers shall be permitted to slope under the tread at an angle of 30 degrees maximum from vertical. The permitted projection of the nosing shall extend 1 1/2 inches maximum over the tread below.
- Stairs shall have handrails complying with PROWAG 2005 R408.

Figures/Examples



YES NO NA

UNOBSTRUCTED REACH RANGES (PROWAG R406)

Requirements¹

- Forward Reach**
- Where a forward reach is unobstructed, the high forward reach shall be 48 inches maximum and the low forward reach shall be 15 inches minimum above the finish floor or ground.
- Side Reach**
- Where a clear floor or ground space allows a parallel approach to an element and the side reach is unobstructed, the high side reach shall be 48 inches maximum and the low side reach shall be 15 inches minimum above the finish floor or ground.
 - **EXCEPTION:** An obstruction shall be permitted between the clear floor or ground space and the element where the depth of the obstruction is 10 inches maximum. (2011 PROWAG R406.3)

Figures/Examples

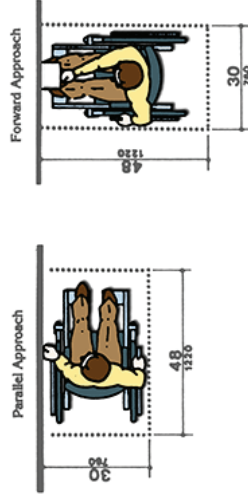
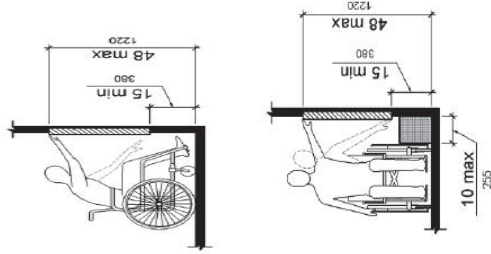

YES NO NA

CURB RAMPS (PROWAG R303)

Requirements 1

YES NO NA

Figures/Examples

A curb ramp, blended transition, or a combination of curb ramps and blended transitions shall connect the pedestrian access routes at each pedestrian street crossing.

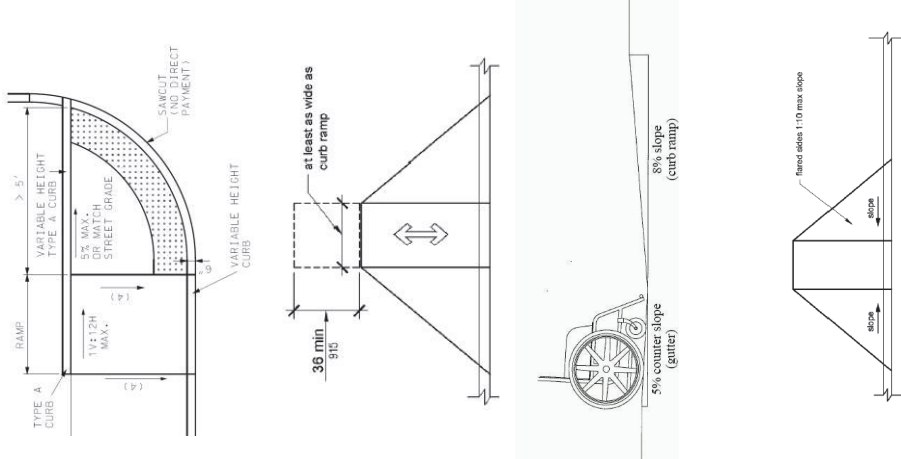

- The clear width of ramps, excluding the flares, shall be 4.0 feet minimum.
 - Ramp runs shall have a running slope between 5 percent minimum and 8.33 percent maximum but shall not require the ramp length to exceed 15.0 feet.
- Exception: 15 Foot Rule:** The running slope for a curb ramp is not limited to 8.33 percent maximum if the constructed curb ramp length exceeds 15 feet in length.
- Cross slope of ramp runs shall be 2 percent maximum. (Roadway Grade Exception may be considered)
 - The cross slope at midblock crossings shall be permitted to be warped to meet street or highway grade.
 - Ramps shall have landings at the top and the bottom of each ramp run.
 - The landing clear width shall be at least as wide as the widest ramp run leading to the landing.
 - The landing clear length shall be 5.0 feet long minimum.
 - Ramps that change direction between runs at landings shall have a clear landing 5.0 feet minimum by 5.0 feet minimum.
 - Handrails and Edge protection shall not be required on curb ramps and their landings.
 - Curb height = 0 inches within curb ramp spaces. 2
 - Curb ramps must be flush with street.
 - The counter slope of the gutter or street at the foot of a curb ramp, landing, or blended transition shall be 5 percent maximum. (R303.3.5)
 - The adjacent surfaces at transitions at curb ramps to walks, gutters, and streets shall be at the same level.
 - Flared sides with a slope of 10 percent maximum, measured parallel to the curbline, shall be provided where a pedestrian circulation path crosses the curb ramp.
 - In alterations, where there is no landing at the top of curb ramps, curb ramp flares shall be provided and shall not be steeper than 1:12.
 - Detectable warning surfaces shall be provided, where a curb ramp, landing, or blended transition connects to a street.
 - Gratings, access covers, and other appurtenances shall not be located on curb ramps, landings, blended transitions, and gutters within the pedestrian access route.
 - Grade breaks shall not be permitted on the surface of curb ramps, blended slopes that meet at grade breaks shall be flush.
 - Grade Breaks at the top and bottom of curb ramp runs shall be perpendicular to the direction of the ramp run.

15 Foot Rule: For a compliant curb ramp to exceed 8.33 percent running grade, its constructed length must exceed 15.0 feet.

Figures/Examples

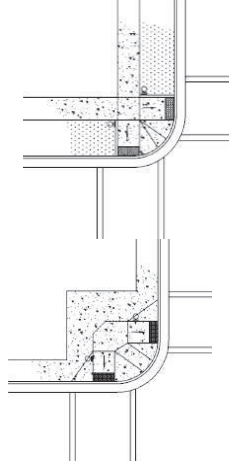

Perpendicular Ramps

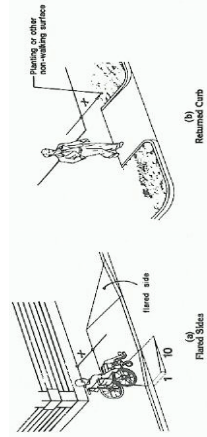

X = 4"Min.

Flared Sides in Pathway Not in Pathway Flared Sides

Roadway Grade Exception:

Where curb ramps, landings and blended transitions are contained within a street or highway right-of-way, the grade of the pedestrian access route is permitted to be modified to equal the general grade established for the adjacent street or highway.

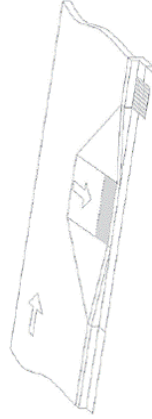

Requirements¹

- Perpendicular curb ramps shall have a running slope that cuts through or is built up to the curb at right angles or meets the gutter grade break at right angles.
- The clear width of landings, blended transitions, and curb ramps, excluding flares, shall be 4.0 feet minimum.
- The running slope shall be 5 percent minimum and 8.33 percent maximum but shall not require the ramp length to exceed 15.0 feet.
- The cross slope at intersections shall be 2 percent maximum. (Roadway Grade Exception may be considered)
- The cross slope at midblock crossings shall be permitted to be warped to meet street or highway grade.

Roadway Grade Exception: The grade of pedestrian access routes within sidewalks is permitted to equal the general grade established for the adjacent street or highway. The cross slope of curb ramps, blended transitions, landings, and turning spaces at pedestrian street crossings without yield or stop control where vehicles can proceed through the intersection without slowing or stopping, and at midblock pedestrian street crossings are permitted to equal the street or highway grade.

- A landing 4.0 feet minimum by 4.0 feet minimum shall be provided at the top of the curb ramp and shall be permitted to overlap other landings and clear space.
- Flared sides with a slope of 10 percent maximum, measured parallel to the curb line, shall be provided where a pedestrian circulation path crosses the curb ramp.
- If the flared sides are not in the pathway (grass next to ramp), then there is no maximum slope and can be vertical curbs. (See adjacent figure for further explanation.)
- Detectable warning surfaces shall be provided, where a curb ramp, landing, or blended transition connects to a street.
- Gratings, access covers, and other appurtenances shall not be located on curb ramps, landings, blended transitions, and gutters within the pedestrian access route.
- Grade breaks at the top and bottom of perpendicular curb ramps shall be perpendicular to the direction of ramp run. At least one end of the bottom grade break shall be at the back of curb.
- Grade breaks shall not be permitted on the surface of curb ramps, blended transitions, landings, and gutter areas within the pedestrian access route. Surface slopes that meet at grade breaks shall be flush.
- Where both ends of the bottom grade break are 5.0 feet or less from the back of curb, the detectable warning shall be located on the ramp surface at the bottom grade break. Where either end of the bottom grade break is more than 5.0 feet from the back of curb, the detectable warning shall be located on the lower landing.

YES

NO

NA

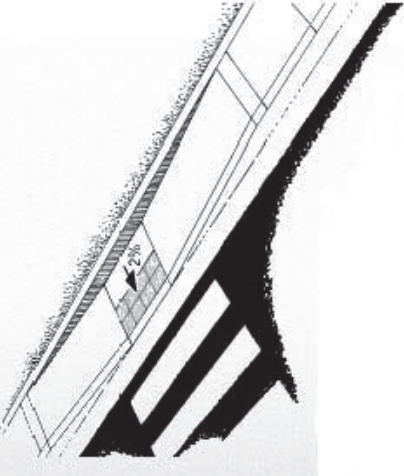
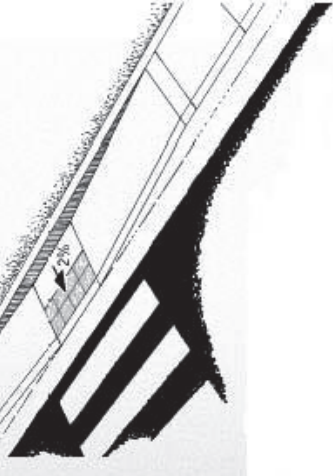
Figures/Examples	Requirements ¹	YES	NO	NA
 <p>Curb Ramps and landings that are contained within a street or highway border may use the Roadway Grade Exception for slopes or cross slopes in the direction of the roadway travel being matched.</p>	<ul style="list-style-type: none"> • Parallel curb ramps shall have a running slope that is in-line with the direction of sidewalk travel. • The clear width of landings, blended transitions, and curb ramps, excluding flares, shall be 4.0 feet minimum. • The running slope shall be 5 percent minimum and 8.33 percent maximum but shall not require the ramp length to exceed 15.0 feet. • The cross slope shall be 2 percent maximum. (Roadway Grade Exception may be considered) <p>Roadway Grade Exception: The grade of pedestrian access routes within sidewalks is permitted to equal the general grade established for the adjacent street or highway. The cross slope of curb ramps, blended transitions, landings, and turning spaces at pedestrian street crossings without yield or stop control where vehicles can proceed through the intersection without slowing or stopping, and at midblock pedestrian street crossings are permitted to equal the street or highway grade.</p> <ul style="list-style-type: none"> • A landing 4.0 feet minimum by 4.0 feet minimum shall be provided at the bottom of the ramp run and shall be permitted to overlap other landings and clear floor or ground space. • Where a parallel curb ramp does not occupy the entire width of a sidewalk, drop-offs at diverging segments shall be protected. • Detectable warning surfaces shall be provided, where a curb ramp, landing, or blended transition connects to a street. • Gratings, access covers, and other appurtenances shall not be located on curb ramps, landings, blended transitions, and gutters within the pedestrian access route. • Grade breaks shall not be permitted on the surface of curb ramps, blended transitions, landings, and gutter areas within the pedestrian access route. Surface slopes that meet at grade breaks shall be flush. 			
	<ul style="list-style-type: none"> • Blended Transitions shall have a running slope of 5 percent maximum and cross slope shall be 2 percent maximum. • The clear width blended transitions, excluding flares, shall be 4.0 feet minimum. • Detectable warning surfaces shall be provided where a blended transition connects to a street. • Gratings, access covers, and other appurtenances shall not be located on blended transitions within the pedestrian access route. • Grade breaks at the top and bottom of perpendicular curb ramps shall be perpendicular to the direction of ramp run. At least one end of the bottom grade break shall be at the back of curb. Grade breaks shall not be permitted on the surface of blended transitions and gutter areas within the pedestrian access route. Surface slopes that meet at grade breaks shall be flush. 			

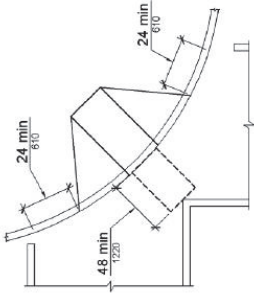
Figures/Examples	Requirements ¹	YES	NO	NA
 	<p>Diagonal Curb Ramps or corner type curb ramps are no longer preferred design types. A design that provides individual ramps for each crossing direction is recommended by the US Access Board.</p> <ul style="list-style-type: none"> • Diagonal Curb Ramps or corner type curb ramps with returned curbs or other well-defined edges shall have the edges parallel to the direction of pedestrian flow. • The bottom of diagonal curb ramps shall have a clear space 48 inches minimum outside active traffic lanes of the roadway. • Diagonal curb ramps provided at marked crossings shall provide the 48 inches minimum clear space within the markings. • Diagonal curb ramps with flared sides shall have a segment of curb 24 inches long minimum located on each side of the curb ramp and within the marked crossing. <p>Roadway Grade Exception: The grade of pedestrian access routes within sidewalks is permitted to equal the general grade established for the adjacent street or highway. The cross slope of curb ramps, blended transitions, landings, and turning spaces at pedestrian street crossings without yield or stop control where vehicles can proceed through the intersection without slowing or stopping, and at midblock pedestrian street crossings are permitted to equal the street or highway grade.</p> <ul style="list-style-type: none"> • Detectable warning surfaces shall be provided, where a curb ramp, landing, or blended transition connects to a street. • Gratings, access covers, and other appurtenances shall not be located on curb ramps, landings, blended transitions, and gutters within the pedestrian access route. • Grade breaks shall not be permitted on the surface of curb ramps, blended transitions, landings, and gutter areas within the pedestrian access route. Surface slopes that meet at grade breaks shall be flush. • Running and cross slope at midblock crossings shall be permitted to be warped to meet street or highway grade. 			

DETECTABLE WARNINGS DEVICES (TRUNCATED DOMES) (PROWAG R304)

Requirements¹

Figures/Examples

A surface feature of truncated dome material built in or applied to the walking surface to advise of an upcoming change from pedestrian to vehicular way.

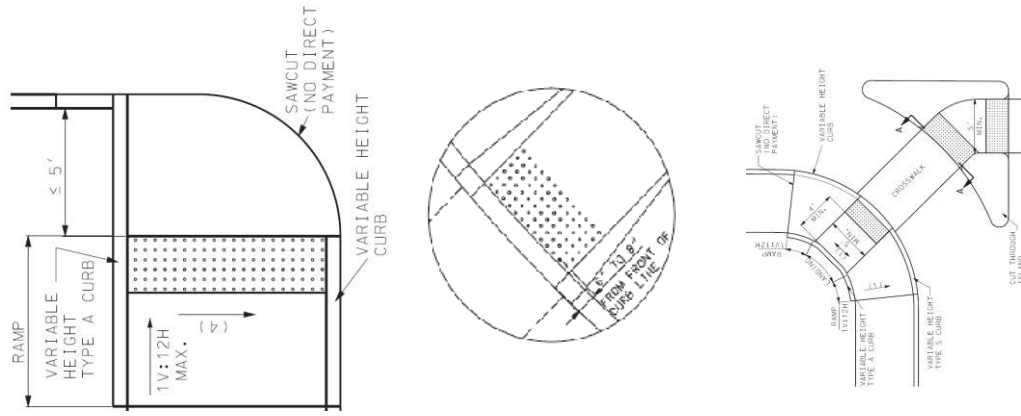

- Detectable warnings shall consist of a surface of truncated domes aligned in a square or radial grid pattern complying with 2010 ADA Standards. Detectable warning surfaces shall contrast visually with adjacent gutter, street or highway, or walkway surfaces, either light-on-dark or dark-on-light.
- Detectable warning surfaces shall extend 24 inches minimum in the direction of travel and the full width of the curb ramp (exclusive of flares), the landing, or the blended transition. Detectable warning surfaces are required where curb ramps, blended transitions, or landings provide a flush pedestrian connection to the street.
- Sidewalk crossings of residential driveways should not generally be provided with detectable warnings, since the pedestrian right-of-way continues across most driveway aprons and overuse of detectable warning surfaces should be avoided in the interests of message clarity. However, where commercial driveways are provided with traffic control devices or otherwise are permitted to operate like public streets, detectable warnings should be provided at the junction between the pedestrian route and the street.
- Perpendicular Curb Ramps: Where both ends of the bottom grade break are 5 feet or less from the back of curb, the detectable warning shall be located on the ramp surface at the bottom grade break. Where either end of the bottom grade break is more than 5 feet from the back of curb, the detectable warning shall be located on the lower landing.
- Landings and Blended Transitions: The detectable warning shall be located on the landing or blended transition at the back of curb.
- Rail Crossings: The detectable warning surface shall be located so that the edge nearest the rail crossing is 6 feet minimum and 15 feet maximum from the centerline of the nearest rail. The rows of truncated domes in a detectable warning surface shall be aligned to be parallel with the direction of wheelchair travel.
- Detectable warnings at cut-through islands shall be located at the curb line in-line with the face of curb and shall be separated by a 2.0 foot minimum length of walkway without detectable warnings. Where the island has no curb, the detectable warning shall be located at the edge of roadway.
- Exception, when detectable warnings are required by a manufacturer's installation specifications to be embedded into concrete with a surrounding edge, domes may be installed at less than the required full width. Under this exception, the detectable warning surface shall never be more than 2 inches from the edge of the curb ramp, the landing, or the blended transition.²
- Detectable warnings shall not be stamped into concrete.

YES

NO

NA

ISLANDS AND MEDIANS (PROWAG R305.4)

Requirements 1

Figures/Examples

- Medians and pedestrian refuge islands in crosswalks shall contain a pedestrian access route, including passing space and connecting to each crosswalk.
- Raised islands in crossings shall be cut through level with the street or have curb ramps and required landings at both sides.
- All median island passage spaces shall provide a clear width of 5 feet minimum. ²
- Medians and pedestrian refuge islands shall be 6.0 feet minimum in length in the direction of pedestrian travel.

Roadway Grade Exception: The grade of pedestrian access routes within sidewalks is permitted to equal the general grade established for the adjacent street or highway. The cross slope of curb ramps, blended transitions, landings, and turning spaces at pedestrian street crossings without yield or stop control where vehicles can proceed through the intersection without slowing or stopping, and at midblock pedestrian street crossings are permitted to equal the street or highway grade.



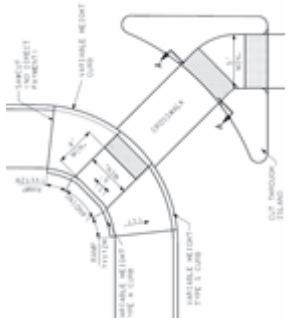
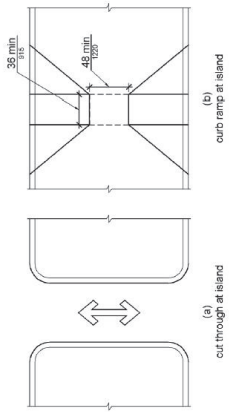

- Each curb ramp shall have a level area 48 inches long minimum by 36 inches wide minimum at the top of the curb ramp in the part of the island intersected by the crossings.
- Each 48 inch minimum by 36 inch minimum area shall be oriented so that the 48 inch minimum length is in the direction of the running slope of the curb ramp it serves. The 48 inch minimum by 36 inch minimum areas and the accessible route shall be permitted to overlap.
- Detectable warning surfaces shall be provided, where a curb ramp, landing, or blended transition connects to a street. Medians and pedestrian refuge islands shall have detectable warnings at curb ramps and blended transitions.
- Detectable warnings at cut-through islands shall be located at the curb line in-line with the face of curb and shall be separated by a 2.0 foot minimum length of walkway without detectable warnings. Where the island has no curb, the detectable warning shall be located at the edge of roadway.
- Gratings, access covers, and other appurtenances shall not be located on curb ramps, landings, blended transitions, and gutters within the pedestrian access route.
- Grade breaks shall not be permitted on the surface of curb ramps, blended transitions, landings, and gutter areas within the pedestrian access route. Surface slopes that meet at grade breaks shall be flush.



YES

NO

NA

ACCESSIBLE PEDESTRIAN SIGNALS (PUSHBUTTONS) (PROWAG R306 and EPG 902.6.1 – EPG 902.6.15)			
Figures/Examples	Requirements ¹	YES	NO
    	<ul style="list-style-type: none"> Each crosswalk with pedestrian signal indication shall have an accessible pedestrian signal which includes audible and vibrotactile indications of the WALK interval at new signalized intersections and shall be considered at existing intersections being altered or are needing maintenance applications. Where a pedestrian pushbutton is provided, it shall be integrated into the accessible pedestrian signal. Accessible pedestrian signals shall be located so that the vibrotactile feature can be contacted from the level landing serving a curb ramp, if provided, or from a clear floor or ground space that is in line with the crosswalk line adjacent to the vehicle stop line. Accessible pedestrian pushbuttons shall be located within a reach range complying with EPG 642. A clear floor or ground space shall be provided at the pushbutton and shall connect to or overlap the pedestrian access route. <p>Roadway Grade Exception: Clear spaces required at accessible pedestrian signals and pedestrian pushbuttons and at other accessible elements are permitted to have a running slope or cross slope consistent with the grade of the adjacent pedestrian access route.</p> <ul style="list-style-type: none"> Pedestrian signals shall comply with PROWAG 2005 R306 and EPG 902.6.1 through 902.6.15. <ul style="list-style-type: none"> Pushbuttons are a minimum 2 inches across in one dimension, raised (not recessed), contrast visually with the housing or mounting, and have a maximum force of 3.5 pounds to activate operable parts. The control face of the pushbuttons is installed parallel to the direction of the crosswalk it serves. The location of pushbuttons for new construction are within a longitudinal distance of 5 feet maximum from the crosswalk line, and 30 inches minimum to 6 feet maximum from the curb line. For audible pedestrian signal devices only, pushbuttons are a minimum 10 feet apart. Pushbuttons are located at a height of approximately 42 inches, but no higher than 48 inches from the ground and within 10 inch reach from a level paved clear floor or ground space with minimum dimensions of 48 inches x 30 inches positioned for a parallel approach to the pushbutton. For a forward approach space (30 x 48 inches) the allowed reach range is 0 inches. Where pushbuttons for the visually impaired are installed, tactile signs are to be provided that meet ADA requirements. 		

PEDESTRIAN STREET CROSSINGS (PROWAG R305 and EPG 642)

Requirements ¹

Figures/Examples

YES **NO** **NA**

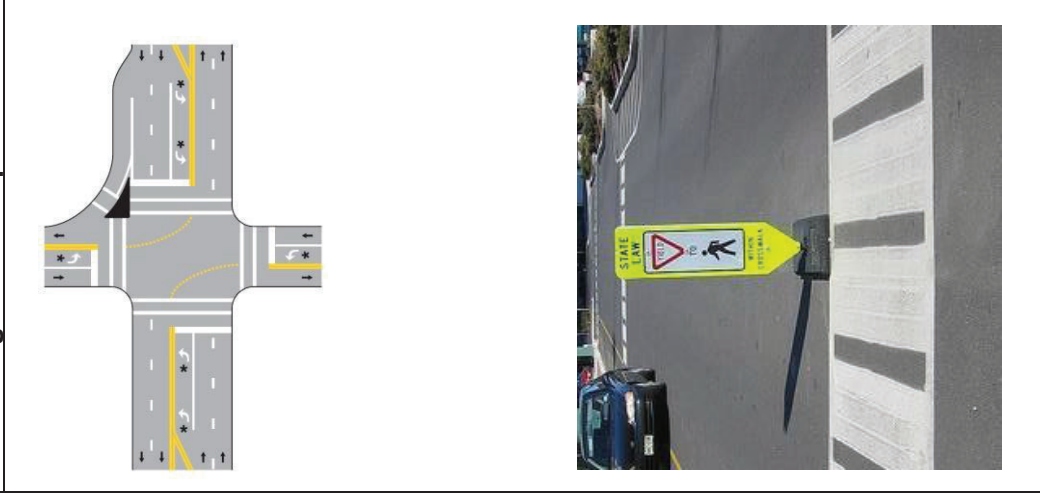

- Crosswalks shall contain a pedestrian access route that connects to departure and arrival walkways through any median or pedestrian refuge island.
- Marked crosswalks shall be 6 feet wide minimum.
- The grade of the pedestrian access route is permitted to equal the general grade established for the adjacent street or highway, except that where pedestrian access routes are contained within pedestrian street crossings a maximum grade of 5 percent is required.
- A 5 percent maximum cross slope is specified for pedestrian access routes contained within pedestrian street crossings without yield or stop control.
- Crossings with Stop Control: The cross slope shall be 2 percent maximum.
- The cross slope at midblock crossings shall be permitted to be warped to meet street or highway grade.
- The running slope shall be 5 percent maximum, measured parallel to the direction of pedestrian travel in the crosswalk.
- Accessible pedestrian signals and pedestrian pushbuttons provided at pedestrian crossings with pedestrian signals (See EPG 642 for applicability) shall comply with EPG 902.6.8 through 902.6.15. Operable parts shall comply with EPG 902.6.9 – 902.6.15.
- Crosswalk pavement marking is 6 inches wide white.
- Stop bar is at minimum 4 feet from the crosswalk.
- Curb ramps at marked crossings shall be wholly contained within the markings, excluding any flared sides.
- Gratings, access covers, and other appurtenances shall not be located on curb ramps, landings, blended transitions, and gutters within the pedestrian access route.
- Grade breaks shall not be permitted on the surface of curb ramps, blended transitions, landings, and gutter areas within the pedestrian access route. Surface slopes that meet at grade breaks shall be flush.
- Beyond the curb face, a clear space of 4.0 feet minimum by 4.0 feet minimum shall be provided within the width of the crosswalk and wholly outside the parallel vehicle travel lane.

ALTERNATE CIRCULATION PATH (PROWAG R302)		
Figures/Examples	Requirements ¹	YES NO NA
	<ul style="list-style-type: none"> • Alternate circulation paths shall contain a pedestrian access route. • To the maximum extent feasible, the alternate circulation path shall be provided on the same side of the street as the disrupted route. • Where the alternate circulation path is exposed to adjacent construction, excavation drop-offs, traffic, or other hazards, it shall be protected with a pedestrian barricade or channelizing device complying with MUTCD 6F-58, 6F-63, and 6F-66. • Pedestrian barricades and channelizing devices shall be continuous, stable, and non-flexible and shall consist of a wall, fence, or enclosures specified in section 6F-58, 6F-63, and 6F-66 of the MUTCD (incorporated by reference; see PROWAG 2005 R104.2.4). • A detectable continuous bottom edge shall be provided 2 inches maximum above the ground or walkway surface. • Devices shall provide a continuous surface or upper rail at 3.0 feet minimum above the ground or walkway surface. • Support members shall not protrude into the alternate circulation path. 	<p>YES NO NA</p>

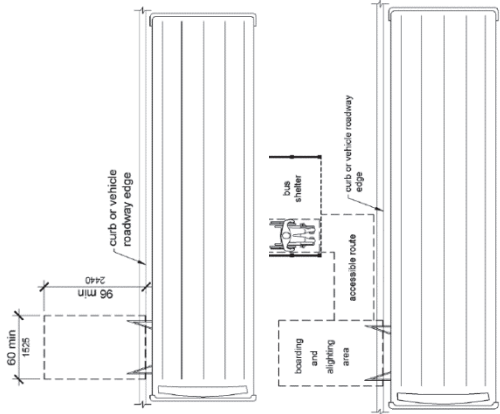
BUS BOARDING AND ALIGHTING AREAS (PROWAG R410)		
Figures/Examples	Requirements ¹	YES NO NA
	<ul style="list-style-type: none"> • Bus stop boarding and alighting areas shall have a firm, stable surface. • Bus stop boarding and alighting areas shall provide a clear length of 8 feet minimum, measured perpendicular to the curb or vehicle roadway edge, and a clear width of 5 feet minimum, measured parallel to the vehicle roadway. • Bus stop boarding and alighting areas shall be connected to streets, sidewalks, or pedestrian paths by an accessible route. • Parallel to the roadway, the slope of the bus stop boarding and alighting area shall be the same as the roadway, to the maximum extent practicable. Perpendicular to the roadway, the slope of the bus stop boarding and alighting area shall not be steeper than 2 percent. • Bus shelters shall provide a minimum 30 inch by 48 inch clear floor or ground space entirely within the shelter. • Bus shelters shall be connected by an accessible route to a boarding and alighting area. 	<p>YES NO NA</p>

¹ Any "NO" answer means that location is ADA non-compliant and needs to be corrected before final acceptance of the work, except as follows. Although exceptions listed in the above requirements may not meet MoDOT current policy standards, work that does meet the minimum ADA standards will be accepted as ADA compliant. Where it is technically infeasible to correct deficiencies as part of the current work, those locations will be labeled as non-compliant and marked "NO". These items will be added to the Transition Plan Inventory for correction at a later date. (Guidance is provided in ADA documents and in the EPG on what may be considered as technically infeasible.)

² A MoDOT requirement.

Unless otherwise noted, all notes on this form are direct ADA requirements as published in either the PROWAG dated November 23, 2005 or ADA/ABA Standards from 2010.

All exceptions and technically infeasible locations should be discussed with the project manager and/or area engineer prior to acceptance of the work. All exceptions and technically infeasible locations will need to be thoroughly documented by the engineer, and that documentation will be attached to this form and retained as part of the final acceptance records.

All slope and grade measurements for ADA compliance will be made using a calibrated 2 foot long digital level.

US Access Board PROWAG

R202.3.1 Prohibited Reduction in Required Access. An alteration shall not decrease or have the effect of decreasing the accessibility of a facility or an accessible connection to an adjacent building or site below the requirements for new construction in effect at the time of the alteration.

Inspector Name: _____	
Inspector Signature: _____	Date: _____
Contractor Representative Name: _____	
Contractor Representative Signature: _____	Date: _____
Resident Engineer or Area Engineer Name: _____	
Resident Engineer or Area Engineer Signature: _____	Date: _____
Distribution:	
<input type="checkbox"/> Project Office <input type="checkbox"/> District Permit Office	

SAMPLE

ADA EXCEPTIONS DOCUMENTATION

Job No. _____ Route _____ County _____ Location _____

<u>Item</u>	<u>Location</u>	<u>Standard</u>	<u>As Built</u>	<u>Discussion</u>
Sidewalk Width	Third Street Sta 3+00 to 7+00 RT	5' wide	Exist 3' wide	Required 5' x 5' Passing Space added at 5+00
Curb Ramp Grade	SE Quad of Main & First	8.33%	11.2%	As-built Curb Ramp is 16.0' long
Parallel Ramp Landing running grade (turning space)	Sta 35+20 to 35+25 Rt Rte 14	2.00%	2.6%	Landing running grade matches existing roadway grade
Sidewalk Grade	Sta 23+45 to 23+52	5.0%	8.4%	Match existing floor at two exist doorways, Straight grade between fixed elevations

Inspector Name: _____	
Inspector Signature: _____	Date: _____
Resident Engineer or Area Engineer Name: _____	
Resident Engineer or Area Engineer Signature:	Date: _____
Distribution: <input type="checkbox"/> Project Office <input type="checkbox"/> District Permit Office	

CONTRACT FORMS