



June 7, 2022

**CITY OF NIXA
TRUMAN BOULEVARD ROADWAY EXTENSION
STBG-9901(832)**

Addendum No. 01

Contract Bidders:

Enclosed is Addendum No. 1 for the above referenced project. Please execute, attach, and submit this Addendum No. 1 with your bid.

In addition, please sign and email a copy of this cover letter to Joe Rickman PE, ACTAR, CJW Transportation Consultants, LLC, jrickman@gocjw.com as acknowledgement of receipt of this addendum notice.

CJW Transportation Consultants, LLC

A handwritten signature in blue ink that reads "Joseph C. Rickman".

Joseph C. Rickman, PE, ACTAR
Senior Transportation Resource Engineer

Company Name

Signature

Printed Name

**CITY OF NIXA
TRUMAN BOULEVARD ROADWAY EXTENSION
STBG-9901(832)**

Addendum No. 01

Clarification Items:

- Item #1: Bid Proposal (Updated Items and Quantities)
- Item #2: Seventh page of Bid Document: Fig 136.9.9, 1 of 3, Jan 2012 – DBE Submittal Form corrected to 7% DBE Goal.
- Item #3: Plan Sheets – Revised plan sheets attached (Sheets No. 33, 34, 38, 42 & 43).

NOTE: Please replace the current four page Bid Proposal with the attached revised document. Please replace the seventh page of Bid Document with updated DBE Goal of 7%. Finally, please replace existing plan sheets with the revised sheets attached.

Federal Wage Determination:

- Item #1: Updated federal wage order, dated 06/03/2022, is attached and shall replace the federal wage order included in the original bid documents.

Company Name

Seal

Signature

Printed Name

Title

Address

City/State/Zip

Telephone Number

PROPOSAL

THE UNDERSIGNED hereby proposes to furnish the labor and material for:

Project:

**PUBLIC IMPROVEMENTS FOR
TRUMAN BOULEVARD ROADWAY EXTENSION
MODOT STBG-9901(832)**

in the City of Nixa, Missouri, according to the Drawings, Contract Documents and general specifications for such work on file in the office of the City Engineer and Director of Public Works, together with the terms and conditions to be stipulated in the general contract forms, now adopted by the City of Nixa, as advertised to be let on **June 23, 2022**, at the following prices to-wit:

TRUMAN BOULEVARD ROADWAY EXTENSION MODOT STBG-9901(832)					
ITEM #	ITEM DESCRIPTION	UNIT	QTY.	Unit Price Dollars Cents	Extended Total Dollars Cents
1	CLEARING AND GRUBBING	ACRE	4		
2	REMOVAL OF IMPROVEMENTS	L.S.	1		
3	UNCLASSIFIED EXCAVATION	C.Y.	7,977		
4	EMBANKMENT IN PLACE	C.Y.	2,500		
5	COMPACTING EMBANKMENT	C.Y.	4,000		
6	MISC. {Undergrading - Unclassified Excavation}	C.Y.	2,500		
7	FURNISHING ROCK FILL	C.Y.	2,500		
8	PLACING ROCK FILL	C.Y.	2,500		
9	CURB REMOVAL	L.F.	100		
10	TYPE 1 AGGREGATE FOR BASE (7 IN. THICK)	S.Y.	15,954		
11	BITUMINOUS PAVEMENT MIXTURE PG64- 22, (BP-2) (2" THICK)	TON	1,773		
12	BITUMINOUS PAVEMENT MIXTURE PG64- 22 (BASE) (5" THICK)	TON	4,432		

13	CONCRETE PAVEMENT (8 IN. NON-REINF)	SY	144		
14	MISC. {Replace 5 strand barbed wire fence (including gates)}	L.F.	1,800		
15	CONCRETE CURB RAMP (6" Thick)	S.F.	1,506		
16	CONCRETE SIDEWALK, 4 IN. (Includes 4" Type 1 Base Rock, Extended 6" Beyond Sidewalk, Both Sides)	S.Y.	5,544		
17	PAVED DITCH	S.Y.	69		
18	ROCK LINING	C.Y.	6		
19	MISC. {6 IN Concrete Islands - Roundabout}	S.Y.	190		
20	MISC. {30" Concrete Curb and Gutter (Includes 4" Type 1 Base Extended 12 IN Past Curb)}	L.F.	7,466		
21	MISC. {3 1/2 IN Mountable Concrete Apron - Roundabout}	S.Y.	490		
22	CONSTRUCTION SIGNS	S.F.	256		
23	CHANNELIZER (TRIM LINE)	EACH	60		
24	TYPE III MOVEABLE BARRICADE	EACH	24		
25	"CHANGEABLE MESSAGE SIGN WITHOUT COMMUNICATION INTERFACE, CONTRACTOR FURNISHED, CONTRACTOR RETAINED"	EACH	3		
26	MOBILIZATION	L.S.	1		
27	CONTRACTOR FURNISHED SURVEYING AND STAKING	L.S.	1		
28	15 IN. REINF. CONCRETE PIPE (RCP)	L.F.	665		
29	18 IN. REINF. CONCRETE PIPE (RCP)	L.F.	1,285		
30	24 IN. REINF. CONCRETE PIPE (RCP)	L.F.	217		
31	MISC. {3' x 7' Curb Inlet (Nixa Standard)}	EACH	24		
32	MISC. {5' x 5' Concrete Box - Inlet / Outlet Structure}	EACH	1		

33	MISC. {5' x 5' Concrete Box – Area Inlet w / Grate}	EACH	1		
34	18 IN. CONCRETE FLARED END SECTION	EACH	3		
35	SEEDING - WARM SEASON MIXTURES	ACRE	3.5		
36	ROCK DITCH CHECK	L.F.	100		
37	CURB INLET CHECK	EACH	25		
38	SEDIMENT REMOVAL	C.Y.	75		
39	TEMPORARY SEEDING AND MULCHING	ACRE	2		
40	SILT FENCE	L.F.	3,000		
TOTAL BID (TRUMAN BOULEVARD ROADWAY EXTENSION)					
TOTAL BID (TRUMAN WATERLINE AND ELECTRICAL EXTENSION)					
TOTAL BID (ROADWAY, WATERLINE, AND ELECTRICAL EXTENSION)					

The undersigned agrees to enter into a contract within ten (10) days from notice of award should this proposal be accepted, and enter into bonds with good and sufficient securities, to complete the work on or before a date to be specified in the Notice to Proceed, and to fully complete the work by June 16, 2023. A penalty of \$2,000 per calendar day thereafter shall be instituted; the amount shall be deducted from the contract price. In order to pay all labor employed and material used in connection with this work and to adjust all claims or liens that may arise in consequence of said work, to the satisfaction of the Director of Public Works, above said bonds shall also indemnify and save harmless the said City from all damages or injuries to any person or persons, either in the employ of the contractor, his agents, servants or employees. In the event of the failure of the undersigned to enter into such contract within ten (10) days of the award, then the deposit or certified check of five percent (5%) of the Total Contract Bid Amount as surety is therefore forfeited to the City of Nixa.

All applicable laws, ordinances, and the rules and regulations of all authorities having jurisdiction over construction of the PROJECT shall apply to the Contract throughout.

Each BIDDER is responsible for inspecting the site and for reading and being thoroughly familiar with the CONTRACT DOCUMENTS. The failure or omission of any BIDDER to do any of the foregoing shall in no way relieve any BIDDER from the any obligation in respect to his BID.

The low BIDDER shall supply the names and addresses of the major material SUPPLIERS AND SUBCONTRACTORS when requested to do so by the OWNER.

Dated _____ day of _____, 20____.

Company _____

Address _____

Signature _____

(Print Name) _____

DBE Submittal Forms

(6) DBE Submittal Forms: This form must be submitted by 4 p.m. three (3) business days after bid opening.

(A) DBE Contract Goal: By submitting this bid, the bidder certifies that the bidder is familiar with the DBE Program Requirements in this contract. The contract DBE goal for the amount of work to be awarded is 7% of the total federal project price. The bidder shall also complete the DBE Submittal Form in accordance with the program requirements.

(B) DBE Participation: The bidder certifies that it will utilize DBE's as follows:

_____ % OF TOTAL FEDERAL CONTRACT

NOTE: Bidder must fill in the above blank. If no percentage is specified, the bidder certifies that it agrees to, and will comply with the contract goal. If a percentage below the contract goal is specified, then the bidder must submit complete documentation of good faith efforts to meet the DBE contract goal, immediately below.

(C) Certification of Good Faith Efforts to Obtain DBE Participation: By submitting its signed bid, the bidder certifies under penalty of perjury and other provisions of law, that the bidder took each of the following steps to try to obtain sufficient DBE participation to achieve the Commission's proposed DBE Contract Goal: (Attach additional sheets if necessary).

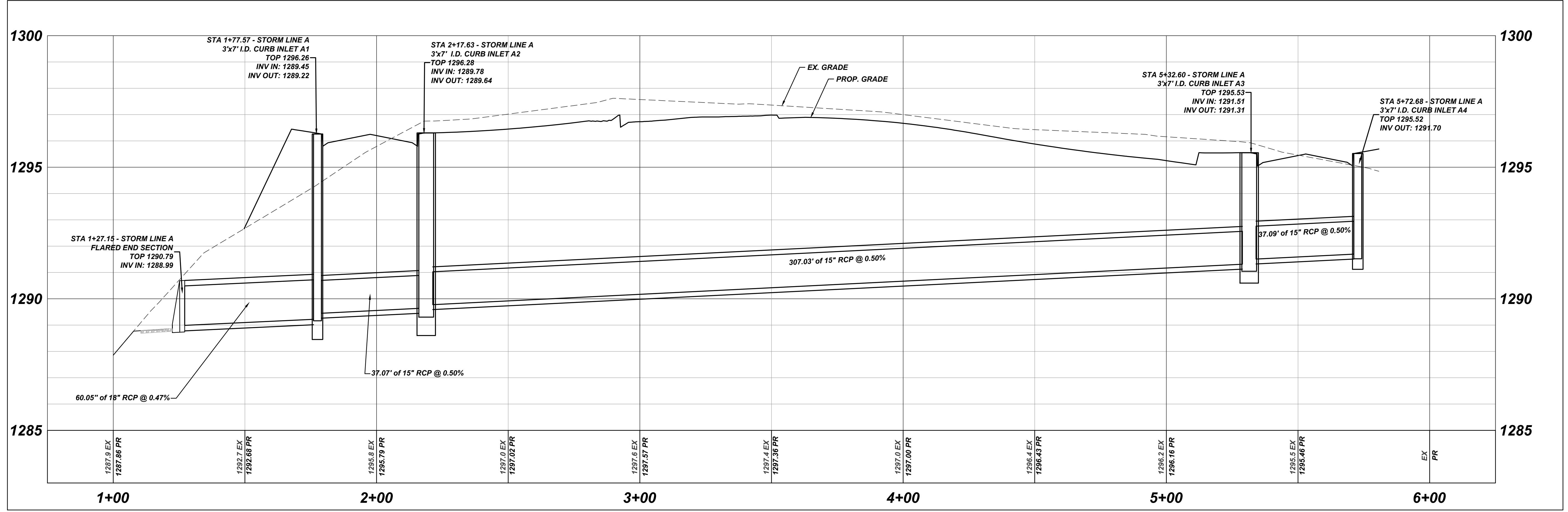
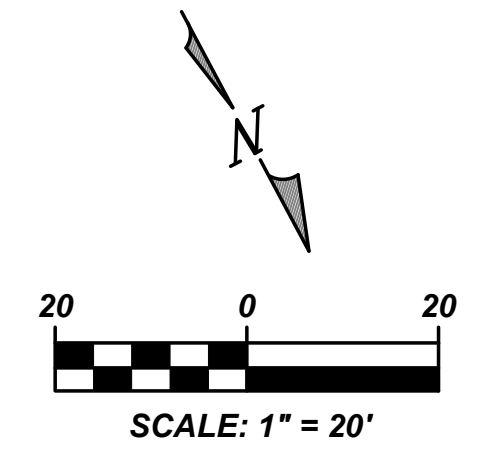
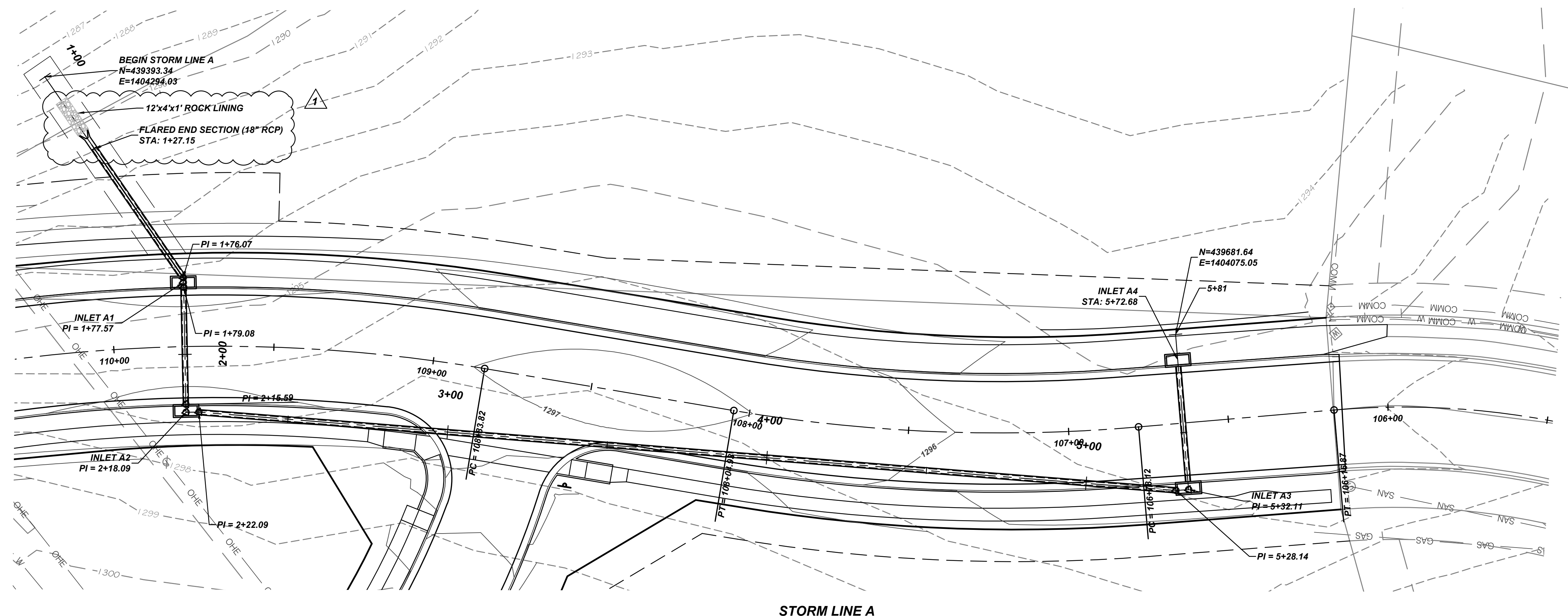

STORM LINE A PROFILE
 SCALE: 1"=20'

G:\15018C - Truman Extension Full Build\Design\dwg\strets\15018C - Storm Plan.dwg - LAST SAVED: 6/7/2022 9:40:51 AM - PLOTTED: 6/7/2022 9:44:32 AM

Prepared by:
CJW
 CJW Transportation Consultants, L.L.C.
 5051 S. National Avenue
 Suite 7A
 Springfield, MO 65810
 Tel: 417.889.3400
 Fax: 417.889.3402
 www.cjw.com



TRUMAN BOULEVARD EXTENSION
DEPARTMENT OF PUBLIC WORKS
NIXA, CHRISTIAN COUNTY, MISSOURI
STBG - 9901 (832)

Date:	06/06/22
Description:	ADDENDUM #1
No.:	
SURVEY BY	CJW
DATE	06/26/2015
DWG	STORM LINE A
DESIGN	CJW
DRAWN	CJW
CHECKED	CJW
SCALE HOR.	1"=20'
SCALE VERT.	1"=2'

STORM P&P

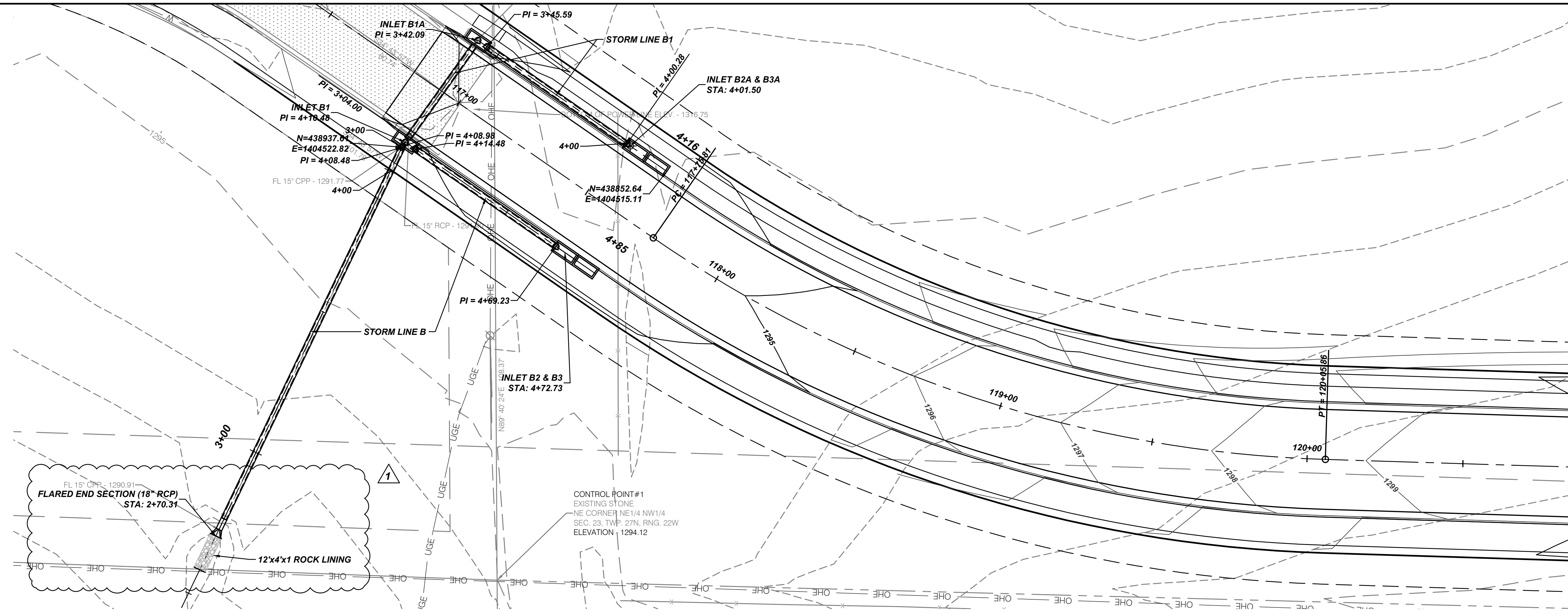

STORM LINE B & B1

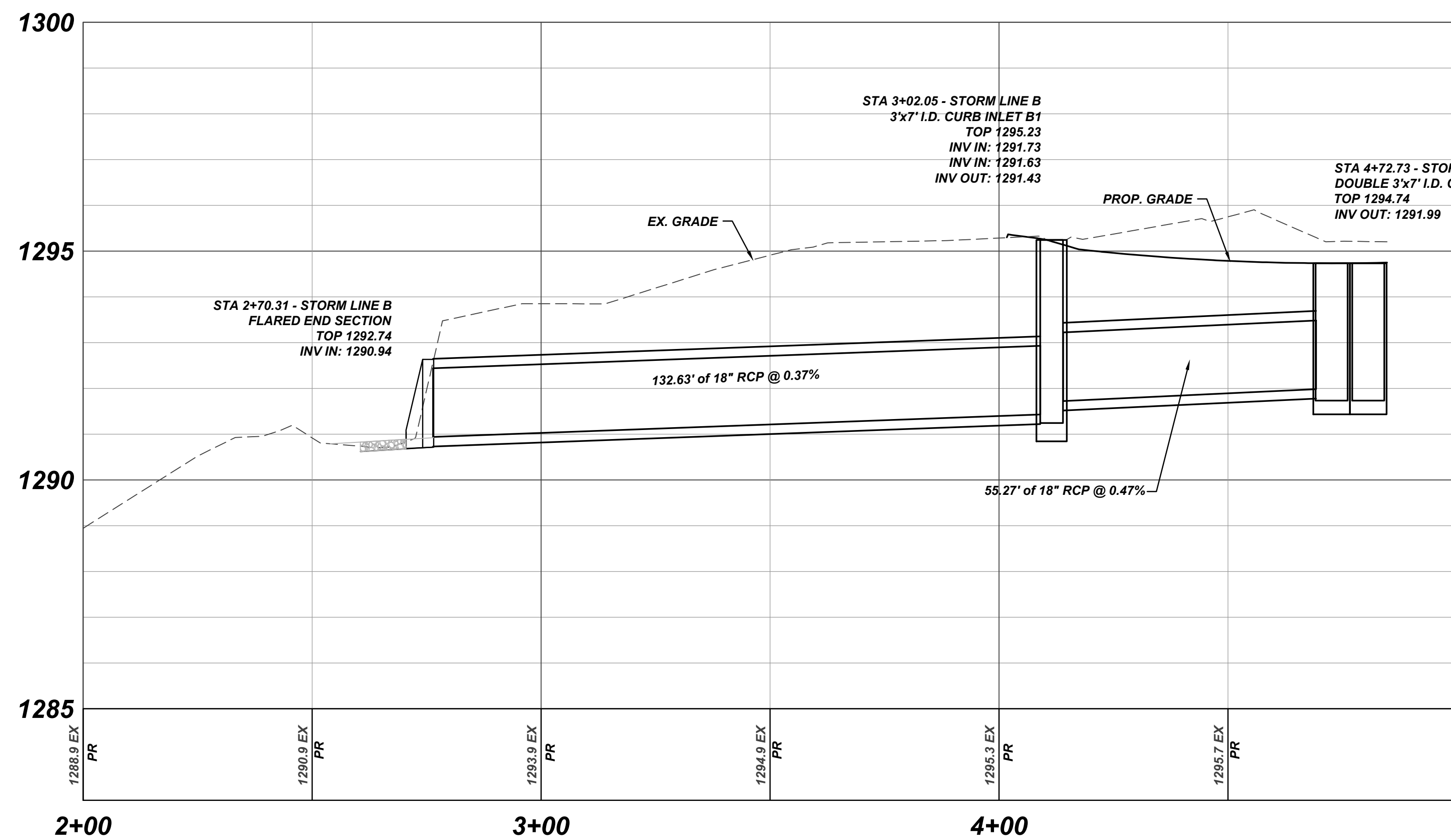
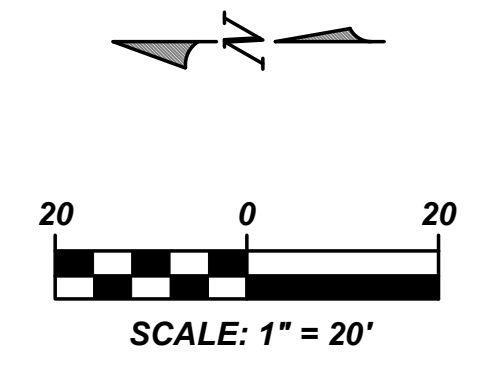

STORM LINE B PROFILE
SCALE: 1"=20'

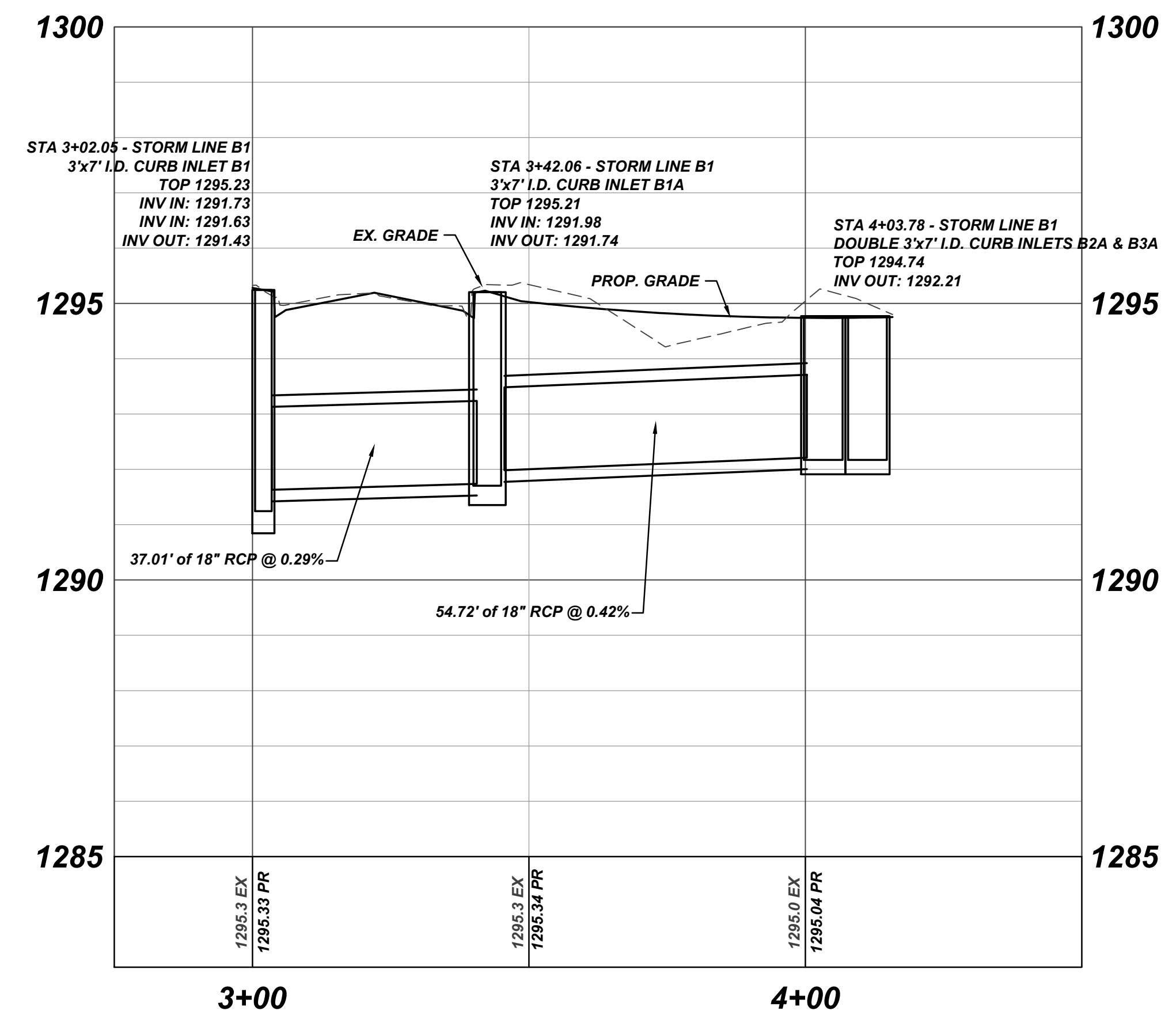

STORM LINE B1 PROFILE
SCALE: 1"=20'

G:\15018C - Truman Extension Full Build\Design\dwg\trms15018C - Storm Plan.dwg - LAST SAVED: 6/7/2022 9:40:51 AM - PLOTTED: 6/7/2022 9:44:11 AM

TRUMAN BOULEVARD EXTENSION
DEPARTMENT OF PUBLIC WORKS
NIXA, CHRISTIAN COUNTY, MISSOURI
STBG - 9901 (832)

Date:	06/06/22
No.:	ADDENDUM #1
DESCRIPTION:	
SURVEY BY:	CJW
DATE:	06/26/2015
DWG:	STORM LINE B
DESIGN:	CJW
DRAWN:	CJW
CHECKED:	CJW
SCALE HOR:	1"=20'
SCALE VERT:	1"=2'

STORM P&P
SHEET NO. **34**
CJW NO. 15018C OF 73

Prepared by:
CJW
CJW Transportation Consultants, L.L.C.
5651 S. National Avenue
Suite 7A
Springfield, MO 65810
Tel: 417.889.5400
Fax: 417.889.5402
www.cjw.com



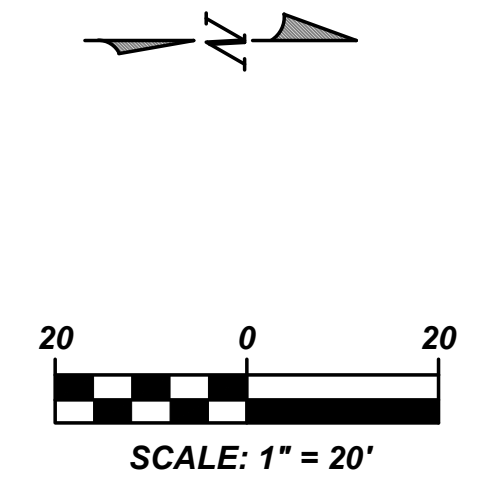
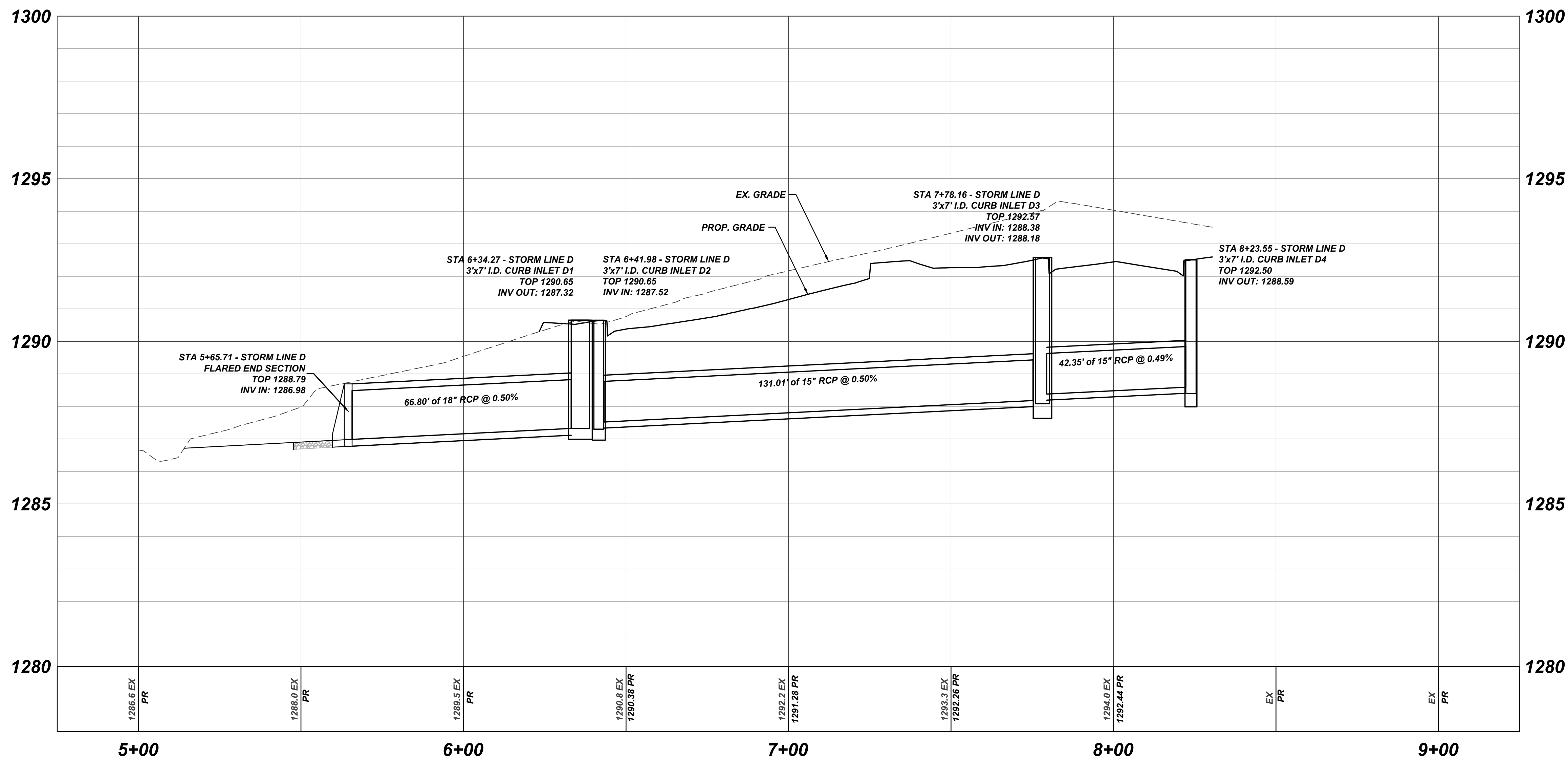
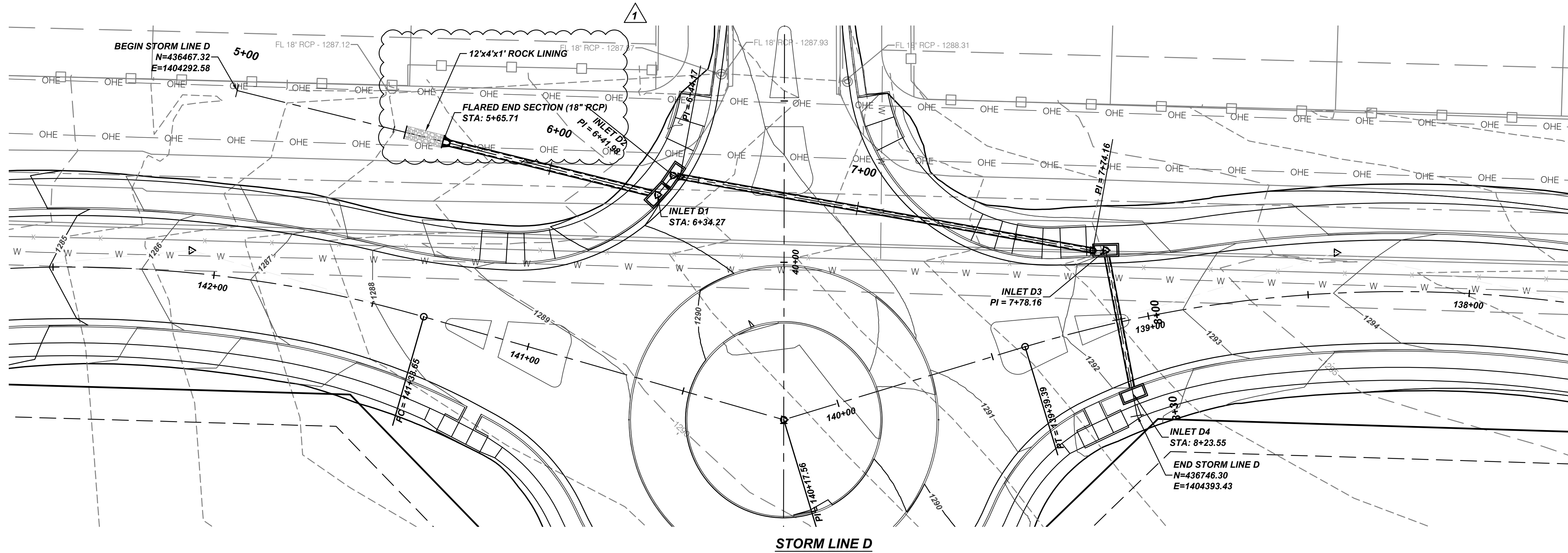

Prepared by:
CJW
CJW Transportation Consultants, L.L.C.
5651 S. National Avenue
Suite 7A
Springfield, MO 65810
Tel: 417.889.5400
Fax: 417.889.5402
www.cjw.com

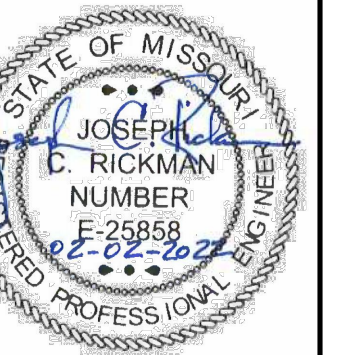

TRUMAN BOULEVARD EXTENSION
DEPARTMENT OF PUBLIC WORKS
NIXA, CHRISTIAN COUNTY, MISSOURI
STBG - 9901 (832)

No.:	ADDENDUM #1
Date:	06/06/22
SURVEY BY	CJW
DATE	06/26/2015
DWG	STORM LINE D
DESIGN	CJW
DRAWN	CJW
CHECKED	CJW
SCALE HOR.	1"=20'
SCALE VERT.	1"=2'

STORM P&P

SHEET NO.
38
OF 73



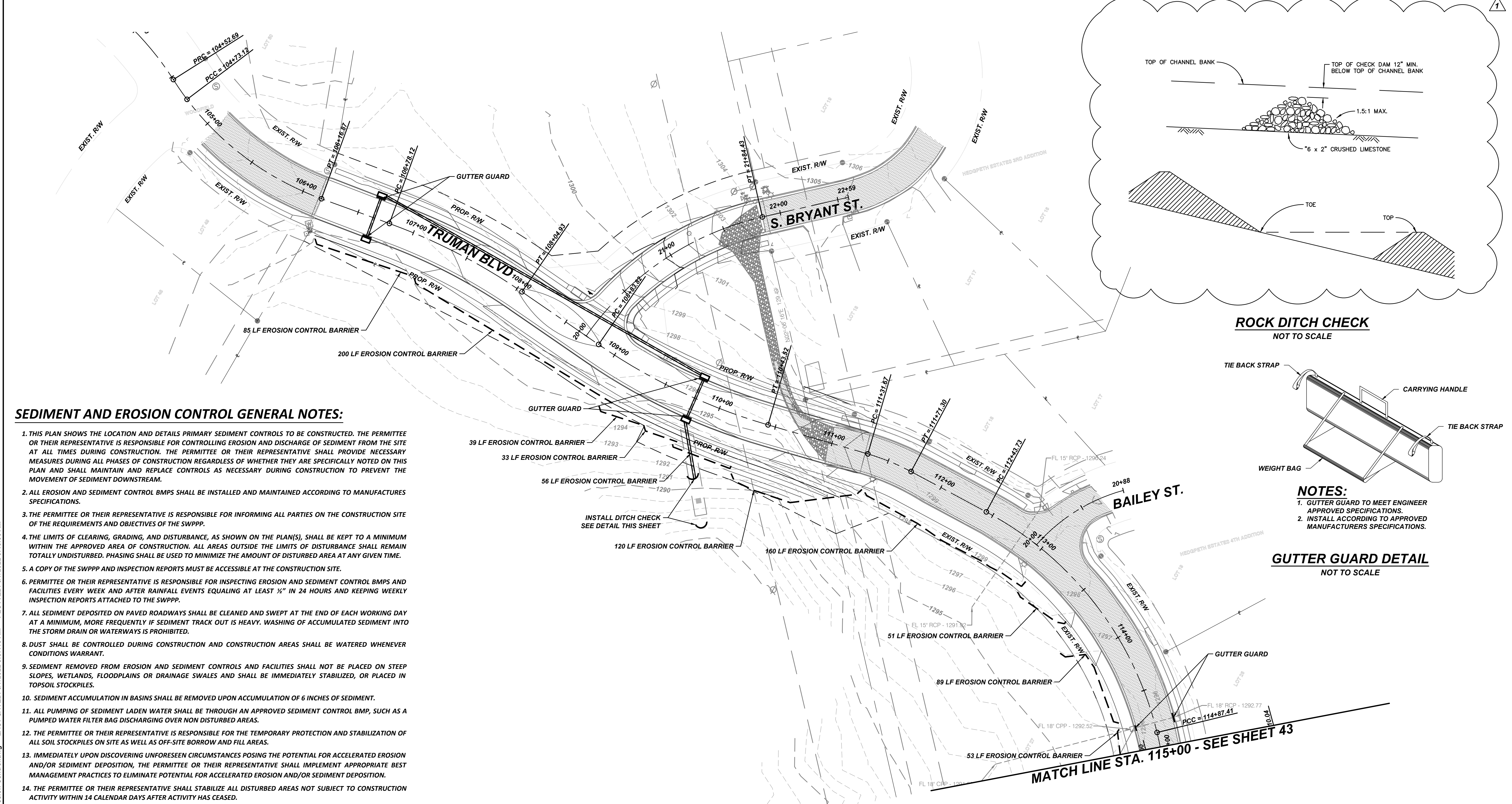

SEDIMENT AND EROSION CONTROL GENERAL NOTES:

1. THIS PLAN SHOWS THE LOCATION AND DETAILS PRIMARY SEDIMENT CONTROLS TO BE CONSTRUCTED. THE PERMITTEE OR THEIR REPRESENTATIVE IS RESPONSIBLE FOR CONTROLLING EROSION AND DISCHARGE OF SEDIMENT FROM THE SITE AT ALL TIMES DURING CONSTRUCTION. THE PERMITTEE OR THEIR REPRESENTATIVE SHALL PROVIDE NECESSARY MEASURES DURING ALL PHASES OF CONSTRUCTION REGARDLESS OF WHETHER THEY ARE SPECIFICALLY NOTED ON THIS PLAN AND SHALL MAINTAIN AND REPLACE CONTROLS AS NECESSARY DURING CONSTRUCTION TO PREVENT THE MOVEMENT OF SEDIMENT DOWNSTREAM.
2. ALL EROSION AND SEDIMENT CONTROL BMPs SHALL BE INSTALLED AND MAINTAINED ACCORDING TO MANUFACTURERS SPECIFICATIONS.
3. THE PERMITTEE OR THEIR REPRESENTATIVE IS RESPONSIBLE FOR INFORMING ALL PARTIES ON THE CONSTRUCTION SITE OF THE REQUIREMENTS AND OBJECTIVES OF THE SWPPP.
4. THE LIMITS OF CLEARING, GRADING, AND DISTURBANCE, AS SHOWN ON THE PLAN(S), SHALL BE KEPT TO A MINIMUM WITHIN THE APPROVED AREA OF CONSTRUCTION. ALL AREAS OUTSIDE THE LIMITS OF DISTURBANCE SHALL REMAIN TOTALLY UNDISTURBED. PHASING SHALL BE USED TO MINIMIZE THE AMOUNT OF DISTURBED AREA AT ANY GIVEN TIME.
5. A COPY OF THE SWPPP AND INSPECTION REPORTS MUST BE ACCESSIBLE AT THE CONSTRUCTION SITE.
6. PERMITTEE OR THEIR REPRESENTATIVE IS RESPONSIBLE FOR INSPECTING EROSION AND SEDIMENT CONTROL BMPs AND FACILITIES EVERY WEEK AND AFTER RAINFALL EVENTS EQUALING AT LEAST 1/8" IN 24 HOURS AND KEEPING WEEKLY INSPECTION REPORTS ATTACHED TO THE SWPPP.
7. ALL SEDIMENT DEPOSITED ON PAVED ROADWAYS SHALL BE CLEANED AND SWEEPED AT THE END OF EACH WORKING DAY AT A MINIMUM, MORE FREQUENTLY IF SEDIMENT TRACK OUT IS HEAVY. WASHING OF ACCUMULATED SEDIMENT INTO THE STORM DRAIN OR WATERWAYS IS PROHIBITED.
8. DUST SHALL BE CONTROLLED DURING CONSTRUCTION AND CONSTRUCTION AREAS SHALL BE WATERED WHENEVER CONDITIONS WARRANT.
9. SEDIMENT REMOVED FROM EROSION AND SEDIMENT CONTROLS AND FACILITIES SHALL NOT BE PLACED ON STEEP SLOPES, WETLANDS, FLOODPLAINS OR DRAINAGE SWALES AND SHALL BE IMMEDIATELY STABILIZED, OR PLACED IN TOPSOIL STOCKPILES.
10. SEDIMENT ACCUMULATION IN BASINS SHALL BE REMOVED UPON ACCUMULATION OF 6 INCHES OF SEDIMENT.
11. ALL PUMPING OF SEDIMENT LADEN WATER SHALL BE THROUGH AN APPROVED SEDIMENT CONTROL BMP, SUCH AS A PUMPED WATER FILTER BAG DISCHARGING OVER NON DISTURBED AREAS.
12. THE PERMITTEE OR THEIR REPRESENTATIVE IS RESPONSIBLE FOR THE TEMPORARY PROTECTION AND STABILIZATION OF ALL SOIL STOCKPILES ON SITE AS WELL AS OFF-SITE BORROW AND FILL AREAS.
13. IMMEDIATELY UPON DISCOVERING UNFORESEEN CIRCUMSTANCES POSING THE POTENTIAL FOR ACCELERATED EROSION AND/OR SEDIMENT DEPOSITION, THE PERMITTEE OR THEIR REPRESENTATIVE SHALL IMPLEMENT APPROPRIATE BEST MANAGEMENT PRACTICES TO ELIMINATE POTENTIAL FOR ACCELERATED EROSION AND/OR SEDIMENT DEPOSITION.
14. THE PERMITTEE OR THEIR REPRESENTATIVE SHALL STABILIZE ALL DISTURBED AREAS NOT SUBJECT TO CONSTRUCTION ACTIVITY WITHIN 14 CALENDAR DAYS AFTER ACTIVITY HAS CEASED.
15. PERMANENT SWALES OR OTHER POINTS OF CONCENTRATED WATER FLOW SHALL BE STABILIZED WITHIN 7 CALENDAR DAYS OF ESTABLISHMENT WITH SOD OR SEED WITH APPROVED EROSION CONTROL MATTING OR BY OTHER APPROVED MEASURES.
16. ALL DISTURBED AREAS NOT RECEIVING OTHER PERMANENT STABILIZATION SUCH AS PAVEMENT, ROOFS, SOD, ETC., SHALL BE SEEDED AND MULCHED, AS SPECIFIED IN THE SWPPP BEFORE TEMPORARY SEDIMENT CONTROLS CAN BE REMOVED AND PRIOR TO FINAL APPROVAL OF CONSTRUCTION.
17. AN AREA SHALL BE CONSIDERED TO HAVE ACHIEVED FINAL STABILIZATION WHEN IT HAS A MINIMUM UNIFORM 70% PERENNIAL VEGETATIVE COVER OR OTHER PERMANENT NON-VEGETATIVE COVER WITH A DENSITY SUFFICIENT TO RESIST ACCELERATED SURFACE EROSION AND SUBSURFACE CHARACTERISTICS SUFFICIENT TO RESIST SLIDING AND OTHER MOVEMENTS.
18. AFTER FINAL STABILIZATION HAS BEEN ACHIEVED, TEMPORARY EROSION AND SEDIMENTATION CONTROLS SHALL BE REMOVED. AREAS DISTURBED DURING REMOVAL OF THE CONTROLS SHALL BE STABILIZED IMMEDIATELY.
19. SILT AND DEBRIS MUST BE REMOVED FROM STORM DRAINS, CONVEYANCE CHANNELS, BASINS OR ANY PART OF THE STORMWATER SYSTEM PRIOR TO FINAL SITE STABILIZATION APPROVAL.
20. THE FOLLOWING WILL BE IMPLEMENTED ACCORDING TO LOCAL, STATE, AND FEDERAL REGULATIONS: LIQUID AND SOLID WASTE MANAGEMENT, CHEMICAL AND MATERIAL DELIVERY AND STORAGE, CONCRETE WASTE, PAINTING AND DRYWALL WORK, VEHICLE FUELING, MAINTENANCE AND CLEANING, ASPHALT, SAWCUTTING, CORING, AND GRINDING ACTIVITIES, BUILDING BLASTING AND CLEANING, CEMENT, GROUT AND MORTAR WORK, SANITARY AND SEPTIC WASTES, WATER LINE DISINFECTION, FLUSHING, DEWATERING, AND OTHER NON-STORMWATER DISCHARGES, HAZARDOUS WASTE MANAGEMENT, AND PROHIBITED DISCHARGES.
21. PERMITTEE OR THEIR REPRESENTATIVE SHALL MEET ALL OTHER STATE AND FEDERAL CLEAN WATER REQUIREMENTS.

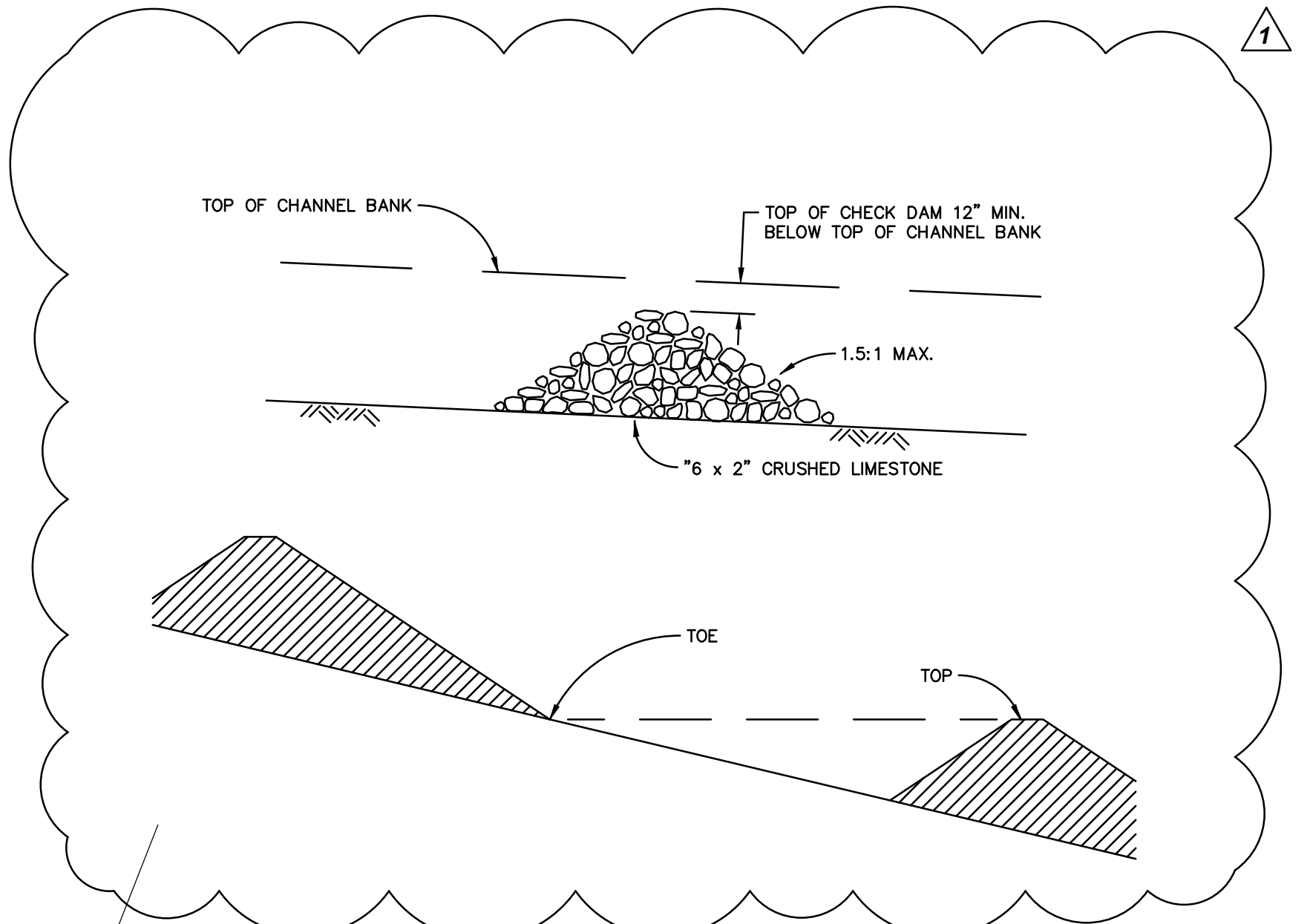

ROCK DITCH CHECK
NOT TO SCALE

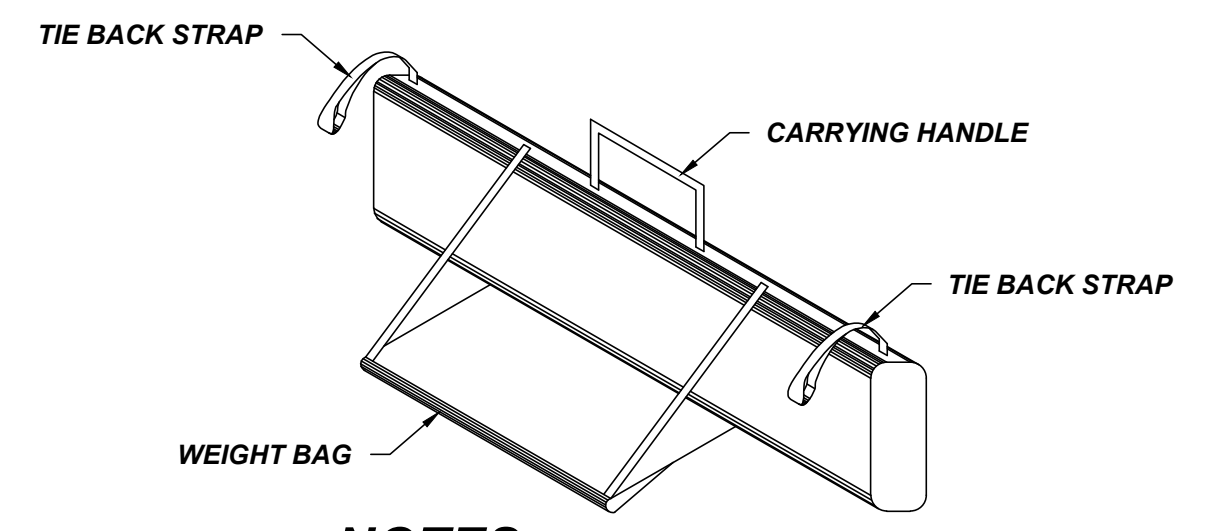

- NOTES:**
1. GUTTER GUARD TO MEET ENGINEER APPROVED SPECIFICATIONS.
 2. INSTALL ACCORDING TO APPROVED MANUFACTURERS SPECIFICATIONS.

GUTTER GUARD DETAIL
NOT TO SCALE

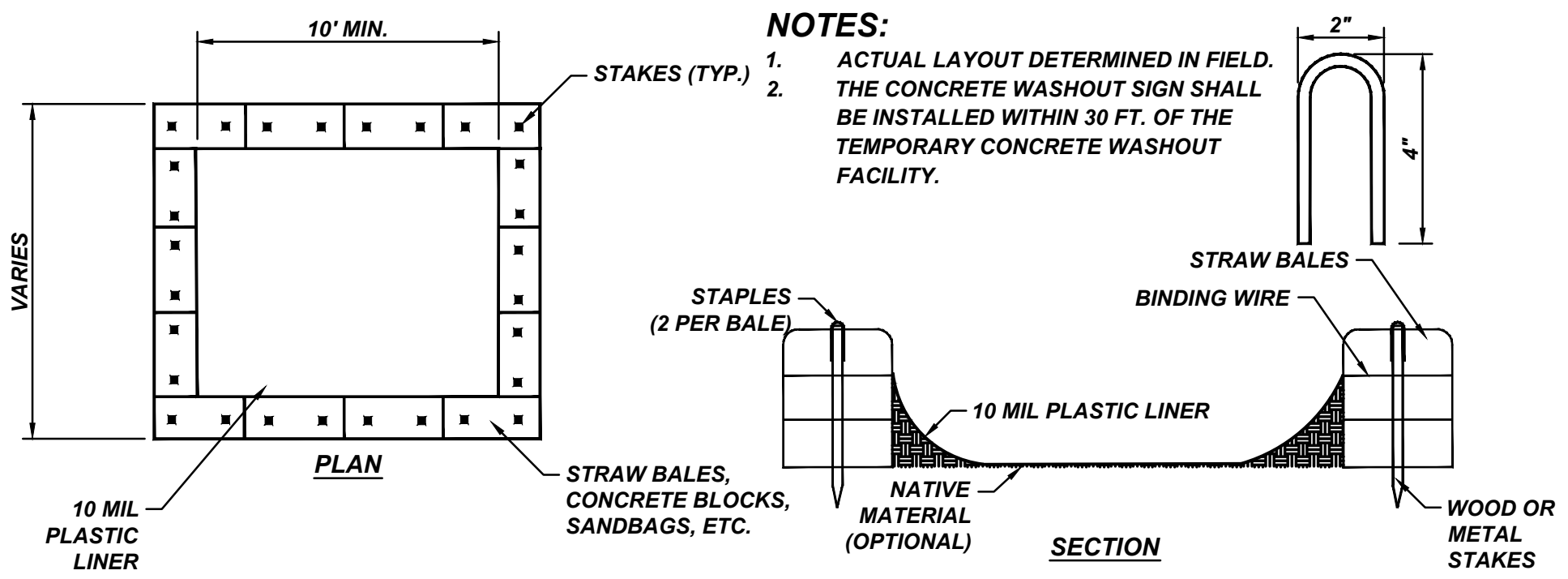

- NOTES:**
1. ACTUAL LAYOUT DETERMINED IN FIELD.
 2. THE CONCRETE WASHOUT SIGN SHALL BE INSTALLED WITHIN 30 FT. OF THE TEMPORARY CONCRETE WASHOUT FACILITY.

TEMPORARY CONCRETE WASHOUT DETAIL
NOT TO SCALE

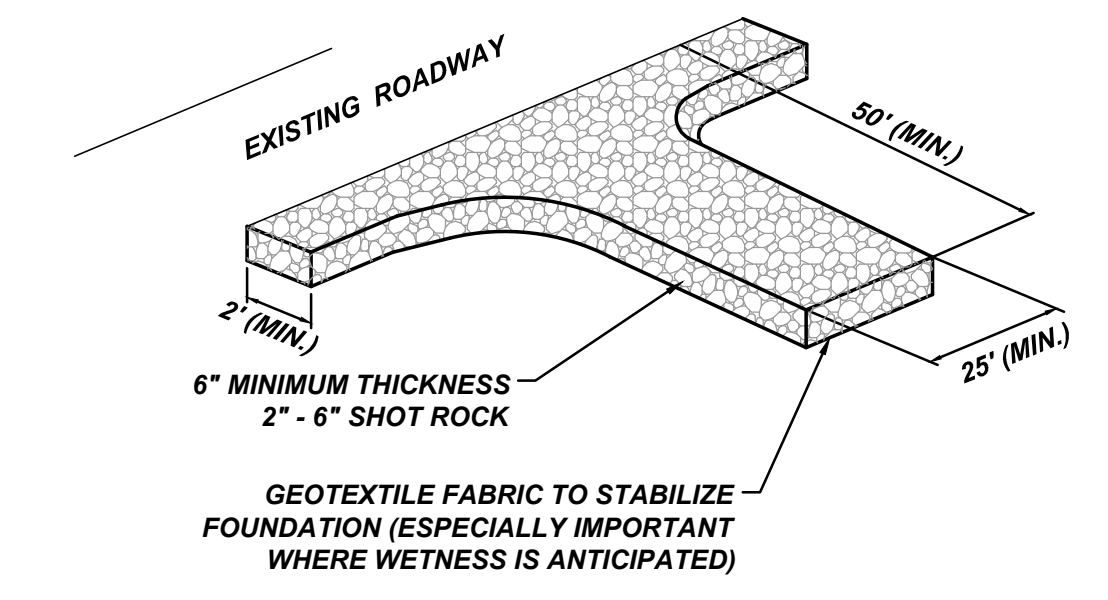

TEMPORARY CONSTRUCTION ENTRANCE
NOT TO SCALE

LEGEND

- - - = EROSION CONTROL BARRIER
- - - = GUTTER GUARD
- - - = DITCH CHECK

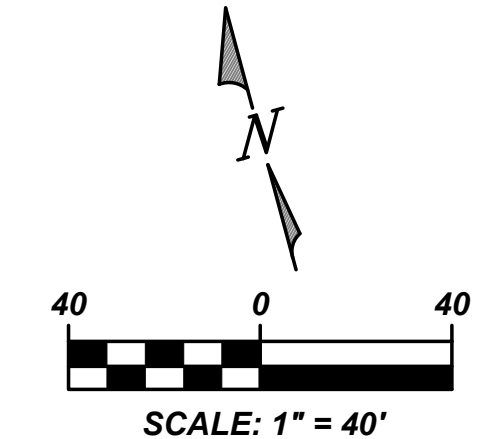

Prepared by:
CJW
CJW Transportation Consultants, L.L.C.
5051 S. National Avenue
Suite 7A
Springfield, MO 65810
Tel: 417.889.5400
Fax: 417.889.5402
www.cjw.com

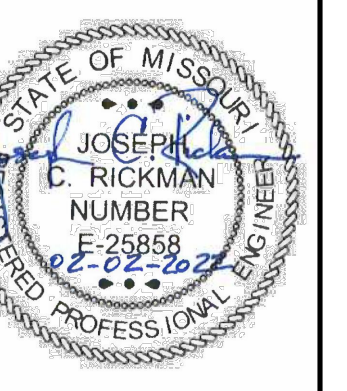

TRUMAN BOULEVARD EXTENSION
DEPARTMENT OF PUBLIC WORKS
NIXA, CHRISTIAN COUNTY, MISSOURI
STBG - 9901 (832)

No.	ADDENDUM #1
Date:	06/06/22
SURVEY BY	CJW
DATE	06/26/2015
DWG	TEMP. EROS.
DESIGN	CJW
DRAWN	CJW
CHECKED	CJW
SCALE HOR.	1"=40'
SCALE VERT.	N/A
TEMP. EROSION CONTROL	
SHEET NO.	42
CJW No.	15018C
OF	73

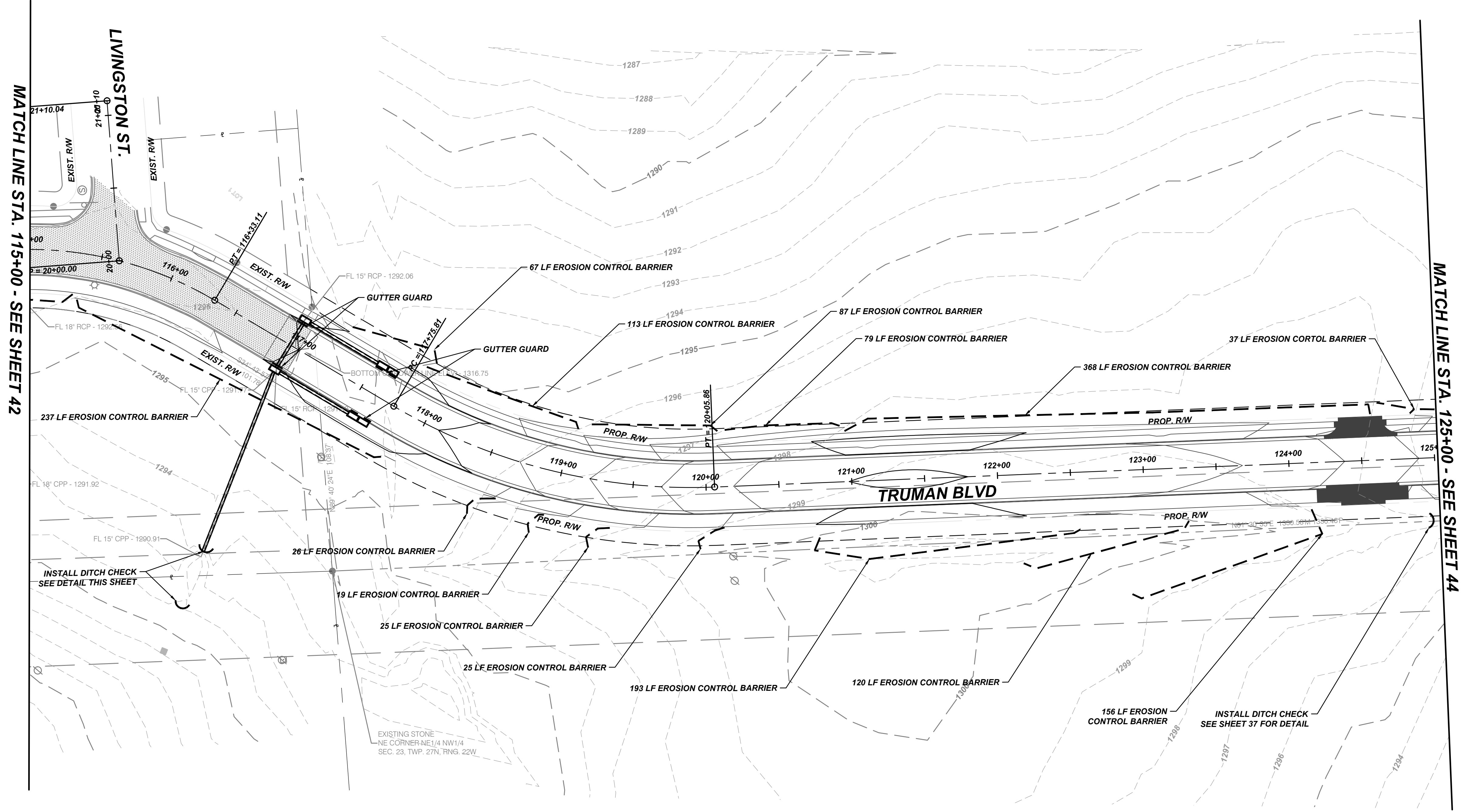

MATCH LINE STA. 115+00 - SEE SHEET 42

MATCH LINE STA. 125+00 - SEE SHEET 44

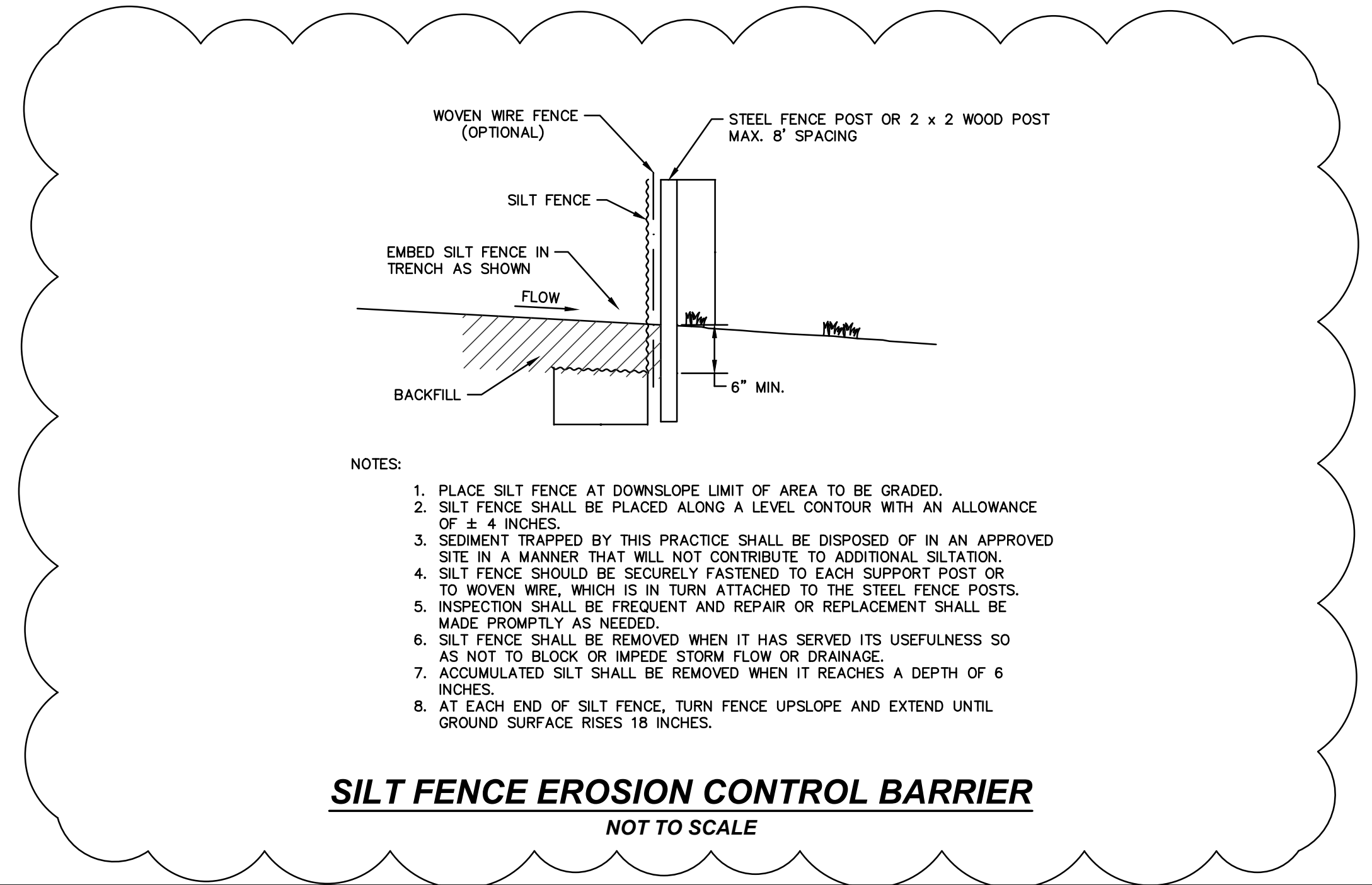

Prepared by:
CJW
CJW Transportation Consultants, L.L.C.
5651 S. National Avenue
Suite 7A
Springfield, MO 65810
Tel: 417.889.3400
Fax: 417.889.3402
www.cjw.com

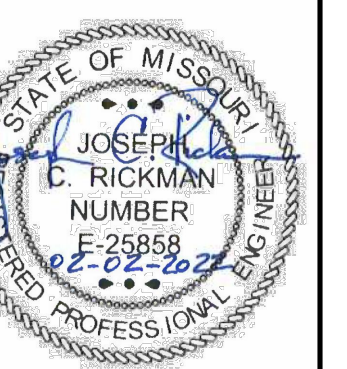

TRUMAN BOULEVARD EXTENSION
DEPARTMENT OF PUBLIC WORKS
NIXA, CHRISTIAN COUNTY, MISSOURI
STBG - 9901 (832)

No.:	06/06/22
Description:	ADDENDUM #1

SURVEY BY	CJW
DATE	06/26/2015
DWG	TEMP. EROS.
DESIGN	CJW
DRAWN	CJW
CHECKED	CJW
SCALE HOR.	1"=40'
SCALE VERT.	N/A

TEMP. EROSION CONTROL
SHEET NO. **43**
CJW NO. 15018C OF 73

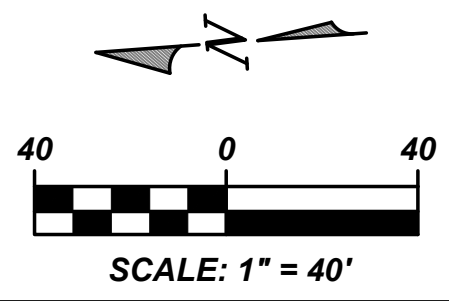

MISSOURI ONE CALL
1-800-DIG-RITE-811
www.mo1call.com

"General Decision Number: MO20220001 06/03/2022

Superseded General Decision Number: MO20210001

State: Missouri

Construction Types: Heavy and Highway

Counties: Missouri Statewide.

HEAVY AND HIGHWAY CONSTRUCTION PROJECTS

Note: Contracts subject to the Davis-Bacon Act are generally required to pay at least the applicable minimum wage rate required under Executive Order 14026 or Executive Order 13658. Please note that these Executive Orders apply to covered contracts entered into by the federal government that are subject to the Davis-Bacon Act itself, but do not apply to contracts subject only to the Davis-Bacon Related Acts, including those set forth at 29 CFR 5.1(a)(2)-(60).

<p>If the contract is entered into on or after January 30, 2022, or the contract is renewed or extended (e.g., an option is exercised) on or after January 30, 2022:</p>	<p>. Executive Order 14026 generally applies to the contract.</p> <p>. The contractor must pay all covered workers at least \$15.00 per hour (or the applicable wage rate listed on this wage determination, if it is higher) for all hours spent performing on the contract in 2022.</p>
<p>If the contract was awarded on or between January 1, 2015 and January 29, 2022, and the contract is not renewed or extended on or after January 30, 2022:</p>	<p>. Executive Order 13658 generally applies to the contract.</p> <p>. The contractor must pay all covered workers at least \$11.25 per hour (or the applicable wage rate listed on this wage determination, if it is higher) for all hours spent performing on that contract in 2022.</p>

The applicable Executive Order minimum wage rate will be adjusted annually. If this contract is covered by one of the Executive Orders and a classification considered necessary for performance of work on the contract does not appear on this wage determination, the contractor must still submit a conformance request.

Additional information on contractor requirements and worker protections under the Executive Orders is available at <https://www.dol.gov/agencies/whd/government-contracts>.

Modification Number	Publication Date
0	01/07/2022
1	01/21/2022
2	02/04/2022
3	02/18/2022
4	02/25/2022
5	03/04/2022
6	04/01/2022
7	04/08/2022
8	04/22/2022
9	05/06/2022
10	05/27/2022

CARP0002-002 05/01/2021

ST. LOUIS COUNTY AND CITY

	Rates	Fringes
Carpenters.....	\$ 39.72	18.90

 CARP0005-006 05/01/2021

CASS (Richards-Gebauer AFB ONLY), CLAY, JACKSON, PLATTE AND RAY
 COUNTIES

	Rates	Fringes
Carpenters:		
CARPENTERS & LATHERS.....	\$ 41.37	18.90
MILLWRIGHTS & PILEDRIVERS...	\$ 41.37	18.90

 CARP0011-001 05/01/2021

	Rates	Fringes
Carpenter and Piledriver		
ADAIR, AUDRAIN (West of Hwy 19), BOONE, CALLAWAY, CHARITON, COLE, COOPER, HOWARD, KNOX, LINN, MACON, MILLER, MONITEAU, MONROE, OSAGE, PUTNAM, RANDOLPH, SCHUYLER, SHELBY AND SULLIVAN COUNTIES.....	\$ 33.69	18.90
ATCHISON, ANDREW, BATES, CALDWELL, CARROLL, DAVIESS, DEKALB, GENTRY, GRUNDY, HARRISON, HENRY, HOLT, LIVINGSTON, MERCER, NODAWAY, ST. CLAIR, SALINE AND WORTH COUNTIES.....	\$ 32.10	18.90
AUDRAIN (East of Hwy.19), RALLS, MARION, LEWIS, CLARK AND SCOTLAND COUNTIES.	\$ 33.70	18.90
BARRY, BARTON, CAMDEN, CEDAR, CHRISTIAN, DADE, DALLAS, DOUGLAS, GREENE, HICKORY, JASPER, LACLEDE, LAWRENCE, MCDONALD, NEWTON, OZARK, POLK, STONE, TANEY, VERNON, WEBSTER AND WRIGHT COUNTIES.	\$ 31.68	18.90
BENTON, MORGAN AND PETTIS...	\$ 32.15	18.90
BOLLINGER, BUTLER, CAPE GIRARDEAU, DUNKLIN, MISSISSIPPI, NEW MADRID, PEMISCOT, PERRY, STE. GENEVIEVE, SCOTT, STODDARD AND WAYNE COUNTIES.....	\$ 33.54	18.90
BUCHANAN, CLINTON, JOHNSON AND LAFAYETTE COUNTIES.....	\$ 32.85	18.90
CARTER, HOWELL, OREGON AND RIPLEY COUNTIES.....	\$ 32.43	18.90
CRAWFORD, DENT, GASCONADE, IRON, MADISON, MARIES, MONTGOMERY, PHELPS, PULASKI, REYNOLDS, SHANNON AND TEXAS COUNTIES.....	\$ 33.53	18.90
FRANKLIN COUNTY.....	\$ 37.14	18.90
JEFFERSON AND ST. CHARLES COUNTIES.....	\$ 39.72	18.90

LINCOLN COUNTY.....	\$ 35.50	18.90
PIKE, ST. FRANCOIS AND		
WASHINGTON COUNTIES.....	\$ 34.36	18.90
WARREN COUNTY.....	\$ 35.96	18.90

 ELEC0001-002 05/31/2020

BOLLINGER, BUTLER, CAPE GIRARDEAU, CARTER, DUNKLIN, FRANKLIN,
 IRON, JEFFERSON, LINCOLN, MADISON, MISSISSIPPI, NEW MADRID,
 PEMISCOT, PERRY, REYNOLDS, RIPLEY, ST. CHARLES, ST. FRANCOIS,
 ST. LOUIS (City and County), STE. GENEVIEVE, SCOTT, STODDARD,
 WARREN, WASHINGTON AND WAYNE COUNTIES

	Rates	Fringes
Electricians.....	\$ 40.61	27.06

 ELEC0002-001 01/01/2022

ADAIR, AUDRAIN, BOONE, CALLAWAY, CAMDEN, CARTER, CHARITON,
 CLARK, COLE, COOPER, CRAWFORD, DENT, FRANKLIN, GASCONADE,
 HOWARD, HOWELL, IRON, JEFFERSON, KNOX, LEWIS, LINCON, LINN,
 MACON, MARIES, MARION, MILLER, MONITEAU, MONROE, MONTGOMERY,
 MORGAN, OREGON, OSAGE, PERRY, PHELPS, PIKE, PULASKI, PUTNAM,
 RALLS, RANDOLPH, REYNOLDS, RIPLEY, ST. CHARLES, ST. FRANCOIS,
 ST. LOUIS (City and County), STE. GENEVIEVE, SCHUYLER,
 SCOTLAND, SHANNON, SHELBY, SULLIVAN, TEXAS, WARREN AND
 WASHINGTON COUNTIES

	Rates	Fringes
Line Construction:		
Equipment Operator.....	\$ 42.67	22.58
Groundman & Truck Driver....	\$ 32.60	18.90
Lineman & Cable Splicer.....	\$ 49.71	25.15

 ELEC0053-004 08/01/2021

	Rates	Fringes
Line Construction: (ANDREW, ATCHINSON, BARRY, BARTON, BUCHANAN, CALDWELL, CEDAR, CHRISTIAN, CLINTON, DADE, DALLAS, DAVIES,, DEKALB, DOUGLAS, GENTRY, GREENE, GRUNDY, HARRISON, HICKORY, HOLT, JASPER, LACLEDE, LAWRENCE, LIVINGSTON, MCDONALD, MERCER, NEWTON, NODAWAY, OZARK, POLK, ST. CLAIR, STONE, TANEY, VERNON, WEBSTER, WORTH AND WRIGHT COUNTIES)		
Groundman Powderman.....	\$ 33.58	18.34
Groundman.....	\$ 31.33	17.60
Lineman Operator.....	\$ 45.60	22.48
Lineman.....	\$ 50.31	24.11

Line Construction; (BATES, BENTON, CARROLL, CASS, CLAY, HENRY, JACKSON, JOHNSON, LAFAYETTE, PETTIS, PLATTE, RAY AND SALINE COUNTIES)		
Groundman Powderman.....	\$ 33.58	18.34
Groundman.....	\$ 31.33	17.60
Lineman Operator.....	\$ 45.60	22.48
Lineman.....	\$ 50.31	24.11

 ELEC0095-001 06/01/2020

BARRY, BARTON, CEDAR, DADE, JASPER, LAWRENCE, MCDONALD, NEWTON, ST CLAIR, AND VERNON COUNTIES

	Rates	Fringes
Electricians:		
Cable Splicers.....	\$ 25.40	12.19
Electricians.....	\$ 27.43	17.44

ELEC0124-007 09/28/2021

BATES, BENTON, CARROLL, CASS, CLAY, COOPER, HENRY, JACKSON, JOHNSON, LAFAYETTE, MORGAN, PETTIS, PLATTE, RAY AND SALINE COUNTIES:

	Rates	Fringes
Electricians.....	\$ 41.79	23.67

ELEC0257-003 03/01/2021

AUDRAIN (Except Cuivre Township), BOONE, CALLAWAY, CAMDEN, CHARITON, COLE, CRAWFORD, DENT, GASCONADE, HOWARD, MARIES, MILLER, MONITEAU, OSAGE, PHELPS AND RANDOLPH COUNTIES

	Rates	Fringes
Electricians:		
Cable Splicers.....	\$ 30.42	16.085
Electricians.....	\$ 34.60	16.38

ELEC0350-002 12/01/2019

ADAIR, AUDRAIN (East of Highway 19), CLARK, KNOX, LEWIS, LINN, MACON, MARION, MONROE, MONTGOMERY, PIKE, PUTNAM, RALLS, SCHUYLER, SCOTLAND, SHELBY AND SULLIVAN COUNTIES

	Rates	Fringes
Electricians.....	\$ 32.50	17.65

ELEC0453-001 09/01/2020

	Rates	Fringes
Electricians:		
CHRISITAN, DALLAS, DOUGLAS, GREENE, HICKORY, HOWELL, LACLEDE, OREGON, OZARK, POLK, SHANNON, WEBSTER and WRIGHT COUNTIES..	\$ 28.10	15.81
PULASKI and TEXAS COUNTIES..	\$ 32.76	16.27
STONE and TANEY COUNTIES....	\$ 23.89	14.99

ELEC0545-003 06/01/2021

ANDREW, BUCHANAN, CLINTON, DEKALB, ATCHISON, HOLT, MERCER, GENTRY, HARRISON, DAVIESS, GRUNDY, WORTH, LIVINGSTON, NODAWAY, AND CALDWELL COUNTIES

	Rates	Fringes
Electricians:.....	\$ 34.00	18.65

ELEC0702-004 12/30/2019

BOLLINGER, BUTLER, CAPE GIRARDEAU, DUNKLIN, MADISON,

MISSISSIPPI, NEW MADRID, PEMISCOT, SCOTT, STODDARD AND WAYNE
COUNTIES

	Rates	Fringes
Line Construction:		
Groundman - Class A.....	\$ 30.31	29% + 7.75
Groundman-Equipment Operator Class II (all other equipment).....	\$ 38.46	29% + 7.75
Heavy-Equipment Operator Class I (all crawler type equipment D-4 and larger)...	\$ 43.88	29% + 7.75
Lineman.....	\$ 53.51	29% + 7.75

ENGI0101-001 05/01/2020

ANDREW, ATCHISON, BATES, BENTON, BUCHANAN, CALDWELL, CARROLL,
CHARITON, CLINTON, COOPER, DAVIESS, DEKALB, GENTRY, GRUNDY,
HARRISON, HENRY, HOLT, HOWARD, JOHNSON, LAFAYETTE, LINN,
LIVINGSTON, MERCER, NODAWAY, PETTIS, SALINE, SULLIVAN AND WORTH
COUNITIES

	Rates	Fringes
Power equipment operators:		
GROUP 1.....	\$ 34.73	18.20
GROUP 2.....	\$ 34.33	18.20
GROUP 3.....	\$ 32.33	18.20

POWER EQUIPMENT OPERATORS CLASSIFICATIONS

GROUP 1: Asphalt roller operator, finish; asphalt paver and spreader; asphalt plant operator; auto grader or trimmer or sub-grader; backhoe; blade operator (all types); boilers - 2; booster pump on dredge; bulldozer operator; boring machine (truck or crane mounted); clamshell operator; concrete mixer paver; concrete plant operator; concrete pump operator; crane operator; derrick or derrick trucks; ditching machine; dragline operator; dredge engineman; dredge operator; drill cat with compressor mounted (self-contained) or similar type self-propelled rotary drill (not air tract); drilling or boring machine (rotary-self-propelled); finishing machine operator; greaser; high loader-fork lift-skid loader (all types); hoisting engineer (2 active drums); locomotive operator (standard guage); mechanics and welders (field and plants); mucking machine operator; pile drive operator; pitman crane or boom truck (all types); push cat; quad track; scraper operators (all types); shovel operator; sideboom cats; side discharge spreader; skimmer scoop operators; slip form paver operator (CMI, Rex, Gomeco or equal); la tourneau rooter (all tiller types); tow boat operator; truck crane; wood and log chippers (all types).

GROUP 2: A-frame truck operator; articulated dump truck; back filler operator; boilers (1); chip spreader; churn drill operator; compressor; concrete mixer operator, skip loader; concrete saws (self-propelled); conveyor operator; crusher operator; distributor operator; elevating grader operator; farm tractor (all attachments); fireman rig; float operator; form grade operator; hoisting engine (one drum); maintenance operator; multiple compactor; pavement breaker, self-propelled hydra-hammer (or similar type); paymill operator; power shield; pumps; roller operator (with or without blades); screening and washing plant; self-propelled street broom or sweeper; siphons and jets; straw blower; stump cutting machine; siphons and jets; tank car heater operator (combination boiler and booster); welding machine; vibrating machine operator (not hand

held); welding machine.
GROUP 3: (a) Oiler;
 (b) Oiler driver
 (c) Mechanic.

HOURLY PREMIUMS:

THE FOLLOWING CLASSIFICATIONS SHALL RECEIVE (\$.25) ABOVE
GROUP 1 RATE: Dragline operator - 3 yds. & over; shovel
3 yds. & over; clamshell 3 yds. & over; Crane, rigs or
piledrivers, 100' of boom or over (incl. jib.), hoist -
each additional active drum over 2 drums

THE FOLLOWING CLASSIFICATIONS SHALL RECEIVE (\$.50) ABOVE
GROUP 1 RATE: Tandem scoop operator; crane, rigs or
piledrivers 150' to 200' of boom (incl. jib.)

THE FOLLOWING CLASSIFICATIONS SHALL RECEIVE (\$.75) ABOVE
GROUP 1 RATE: Crane rigs, or piledrivers 200 ft. of boom
or over (including jib.)

ENGI0101-005 04/01/2022

CASS, CLAY, JACKSON, PLATTE AND RAY COUNTIES

	Rates	Fringes
Power equipment operators:		
GROUP 1.....	\$ 38.42	20.44
GROUP 2.....	\$ 37.38	20.44
GROUP 3.....	\$ 32.91	20.44
GROUP 4.....	\$ 36.26	20.44

POWER EQUIPMENT OPERATORS CLASSIFICATIONS

GROUP 1: Asphalt roller operator, finish; asphalt paver and
spreader; asphalt plant operator; auto grader or trimmer or
sub-grader; backhoe; blade operator (all types); boilers-2;
booster pump on dredge; boring machine (truck or crane
mounted); bulldozer operator; clamshell operator; concrete
cleaning decontamination machine operator; concrete mixer
paver; concrete plant operator; concrete pump operator;
crane operator; derrick or derrick trucks; ditching
machine; dragline operator; dredge engineman; dredge
operator; drillcat with compressor mounted (self-contained)
or similar type self propelled rotary drill (not air
tract); drilling or boring machine (rotary -
self-propelled); finishing machine operator; greaser; heavy
equipment robotics operator/mechanic; horizontal
directional drill operator; horizontal directional drill
locator; loader-forklift - skid loader (all types);
hoisting engineer (2 active drums); locomotive operator
(standard guage); master environmental maintenance
mechanic; mechanics and welders (field and plants);
mucking machine operator; piledrive operator; pitman crane
or boom truck (all types); push cat; quad-track; scraper
operators (all types); shovel operator; side discharge
spreader; sideboom cats; skimmer scoop operator; slip-form
paver (CMI, REX, Gomaco or equal); la tourneau rooter (all
tiller types); tow boat operator; truck crane; ultra high
perssure waterjet cutting tool system operator/mechanic;
vacuum blasting machine operator/mechanic; wood and log
chippers (all types)

GROUP 2: ""A"" Frame truck operator; back filler operator;
boilers (1); chip spreader; churn drill operator; concrete
mixer operator, skip loader; concrete saws
(self-propelled); conveyor operator; crusher operator;
distributor operator; elevating grader operator; farm
tractor (all attachments); fireman rig; float operator;
form grader operator; hoisting engine (1 drum); maintenance

operator; multiple compactor; pavement breaker, self-propelled hydra- hammer (or similar type); power shield; paymill operator; pumps; siphons and jets; stump cutting machine; tank car heater operator (combination boiler and booster); compressor; roller operator (with or without blades); screening and washing plant; self-propelled street broom or sweeper; straw blower; tank car heater operator (combination boiler and booster); vibrating machine operator (not hand held)

GROUP 3: Oilers

GROUP 4: Oiler Driver (All Types)

FOOTNOTE:

HOURLY PREMIUMS FOLLOWING CLASSIFICATIONS SHALL RECEIVE (\$1.00) ABOVE GROUP 1 RATE:

Clamshells - 3 yd. capacity or over; Cranes or rigs, 80 ft. of boom or over (including jib); Draglines, 3 yd. capacity or over;

Piledrivers 80 ft. of boom or over (including jib);

Shovels & backhoes, 3 yd. capacity or over.

 ENGI0101-022 05/01/2019

BARRY, BARTON, CAMDEN, CEDAR, CHRISTIAN, DADE, DALLAS, DOUGLAS, GREENE, HICKORY, JASPER, LACLEDE, LAWRENCE, MCDONALD, NEWTON, OZARK, POLK, ST. CLAIR, STONE, TANEY, VERNON, WEBSTER AND WRIGHT COUNTIES and CITY OF SPRINGFIELD

	Rates	Fringes
Power equipment operators:		
GROUP 1.....	\$ 31.72	14.88
GROUP 2.....	\$ 31.37	14.88
GROUP 3.....	\$ 31.17	14.88
GROUP 4.....	\$ 29.12	14.88

POWER EQUIPMENT OPERATORS CLASSIFICATIONS

GROUP 1: Asphalt finishing machine & trench widening spreader; asphalt plant console operator; autograder; automatic slipform paver; backhoe; blade operator - all types; boat operator - tow; boilers-2; central mix concrete plant operator; clamshell operator; concrete mixer paver; crane operator; derrick or derrick trucks; ditching machine; dozer operator; dragline operator; dredge booster pump; dredge engineman; dredge operator; drill cat with compressor mounted on cat; drilling or boring machine rotary self-propelled; highloader; hoisting engine - 2 active drums; launch hammer wheel; locomotive operator; - standard guage; mechanic and welders; mucking machine; off-road trucks; piledriver operator; pitman crane operator; push cat operator; quad trac; scoop operator - all types; shovel operator; sideboom cats; skimmer scoop operators; trenching machine operator; truck crane.

GROUP 2: A-frame; asphalt hot-mix silo; asphalt plant fireman (drum or boiler); asphalt plant man; asphalt plant man; asphalt plant mixer operator; asphalt roller operator; backfiller operator; barber-greene loader; boat operator (bridges and dams); chip spreader; concrete mixer operator - skip loader; concrete plant operator; concrete pump operator; crusher operator; dredge oiler; elevating grader operator; fork lift; greaser-fleet; hoisting engine - 1; locomotive operator - narrow gauge; multiple compactor; pavement breaker; powerbroom - self-propelled; power shield; rooter; side discharge concrete spreader; slip form finishing machine; stumpcutter machine; throttle man; tractor operator (over 50 h.p.); winch truck.

GROUP 3: Boilers - 1; chip spreader (front man); churn drill operator; clef plane operator; concrete saw operator (self-propelled); curb finishing machine; distributor operator; finishing machine operator; flex plane operator; float operator; form grader operator; pugmill operator; roller operator, other than high type asphalt; screening & washing plant operator; siphons & jets; sub-grading machine operator; spreader box operator, self-propelled (not asphalt); tank car heater operator (combination boiler & booster); tractor operator (50 h.p. or less); Ulmac, Ulric or similar spreader; vibrating machine operator, not hand;

GROUP 4: Grade checker; Oiler; Oiler-Driver

HOURLY PREMIUMS:

The following classifications shall receive \$.25 above GROUP 1 rate:

Clamshells - 3 yds. or over; Cranes - Rigs or Piledrivers, 100 ft. of boom or over (including jib); Draglines - 3 yds. or over; Hoists - each additional active drum over 2 drums; Shovels - 3 yds. or over;

The following classifications shall receive \$.50 above GROUP 1 rate:

Tandem scoop operator; Cranes - Rigs or Piledrivers, 150 ft. to 200 ft. of boom (including jib); Tandem scoop.

The following classifications shall receive \$.75 above GROUP 1 rate:

Cranes - Rigs or Piledrivers, 200 ft. of boom or over (including jib.).

ENGI0513-004 05/05/2022

FRANKLIN, JEFFERSON, LINCOLN, ST CHARLES, AND WARREN COUNTIES

	Rates	Fringes
Power equipment operators:		
GROUP 1.....	\$ 38.36	28.93
GROUP 2.....	\$ 38.36	28.93
GROUP 3.....	\$ 37.06	28.93
GROUP 4.....	\$ 36.61	28.93

POWER EQUIPMENT OPERATORS CLASSIFICATIONS

GROUP 1: Backhoe, Cable; Backhoe, Hydraulic (2 cu yds bucket and under regardless of attachment, one oiler for 2 or 3, two oilers for 4 through 6); Backhoe, Hydraulic over 2 cu yds; Cableway; Crane, Crawler or Truck; Crane, Hydraulic - Truck or Cruiser mounted, 16 tons and over; Crane, Locomotive; crane with boom including jib over 100 ft from pin to pin; Crane using rock socket tool; Derrick, Steam; Derrick Car and Derrick Boat; Dragline, 7 cu yds and over; Dredge; Gradall, Crawler or tire mounted; Locomotive, Gas, Steam & other powers; Pile Driver, Land or Floating; Scoop, Skimmer; Shovel, Power (Electric, Gas, Steam or other powers); Shovel, Power (7 cu yds and over); Switch Boat; Whirley; Air Tugger with air compressor; Anchor Placing Barge; Asphalt Spreader; Athey Force Feeder Loader, self-propelled; Backfilling Machine; Boat Operator - Push Boat or Tow Boat (job site); Boiler, High Pressure Breaking in Period; Boom Truck, Placing or Erecting; Boring Machine, Footing Foundation; Bullfloat; Cherry Picker; Combination Concrete Hoist and Mixer (such as Mixermobile); Compressor, Two 125 CFM and under; Compressor, Two through Four over 125 CFM; Compressor when operator runs throttle; Concrete Breaker (Truck or Tractor mounted); Concrete Pump (such as Pumpcrete machine); Concrete Saw (self-propelled); Concrete

Spreader; Conveyor, Large (not selfpropelled) hoisting or moving brick and concrete into, or into and on floor level, one or both; Crane, Climbing (such as Linden); Crane, Hydraulic - Rough Terrain, self-propelled; Crane, Hydraulic - Truck or Cruiser mounted - under 16 tons; Drilling machine - Self-powered, used for earth or rock drilling or boring (wagon drills and any hand drills obtaining power from other sources including concrete breakers, jackhammers and Barco equipment no engineer required); Elevating Grader; Engine Man, Dredge; Excavator or Powerbelt Machine; Finishing Machine, self-propelled oscillating screed; Forklift; Generators, Two through Six 30 KW or over; Grader, Road with power blade; Greaser; Highlift; Hoist, Concrete and Brick (Brick cages or concrete skips operating or on tower, Towermobile, or similar equipment); Hoist, Three or more drums in use; Hoist, Stack; Hydro-Hammer; Lad-A-Vator, hoisting brick or concrete; Loading Machine such as Barber-Greene; Mechanic on job site

GROUP 2: Air Tugger with plant air; Boiler (for power or heating shell of building or temporary enclosures in connection with construction work); Boiler, Temporary; Compressor, One over 125 CFM; Compressor, truck mounted; Conveyor, Large (not self-propelled); Conveyor, Large (not self-propelled) moving brick and concrete (distributing) on floor level; Curb Finishing Machine; Ditch Paving Machine; Elevator (outside); Endless Chain Hoist; Fireman (as required); Form Grader; Hoist, One Drum regardless of size (except brick or concrete); Lad-A-Vator, other hoisting; Manlift; Mixer, Asphalt, over 8 cu ft capacity; Mixer, one bag capacity or less; Mixer, without side loader, two bag capacity or more; Mixer, with side loader, regardless of size, not Paver; Mud Jack (where mud jack is used in conjunction with an air compressor, operator shall be paid \$.55 per hour in addition to his basic hourly rate for covering both operations); Pug Mill operator; Pump, Sump - self powered, automatic controlled over 2"; Scissor Lift (used for hoisting); Skid Steer Loader; Sweeper, Street; Tractor, small wheel type 50 HP and under with grader blade and similar equipment; Welding Machine, One over 400 amp; Winch, operating from truck

GROUP 3: Boat operator - outboard motor, job site; Conveyors (such as Con-Vay-It) regardless of how used; Elevator (inside); Heater operator, 2 through 6; Sweeper, Floor

GROUP 4: Crane type

HOURLY PREMIUMS:

Backhoe, Hydraulic 2 cu yds or less without oiler - \$2.00;
 Crane, climbing (such as Linden) - \$.50;
 Crane, Pile Driving and Extracting - \$.50
 Crane with boom (including job) over
 100 ft from pin to pin - add \$.01 per foot
 to maximum of \$4.00);
 Crane, using rock socket tool - \$.50;
 Derrick, diesel, gas or electric hoisting material
 and erecting steel (150 ft or more above ground) - \$.50;
 Dragline, 7 cu yds and over - \$.50;
 Hoist, Three or more drums in use - \$.50;
 Scoop, Tandem - \$.50;
 Shovel, Power - 7 cu yds and over - \$.50;
 Tractor, Tandem Crawler - \$.50;
 Tunnel, man assigned to work in tunnel or
 tunnel shaft - \$.50;
 Wrecking, when machines are working on
 second floor or higher - \$.50

ADAIR, AUDRAIN, BOLLINGER, BOONE, BUTLER, CALLAWAY, CAPE GIRARDEAU, CARTER, CLARK, COLE, CRAWFORD, DENT, DUNKLIN, GASCONADE, HOWELL, IRON, KNOX, LEWIS, MACON, MADISON, MARIES, MARION, MILLER, MISSISSIPPI, MONITEAU, MONROE, MONTGOMERY, MORGAN, NEW MADRID, OREGON, OSAGE, PEMISCOT, PERRY, PHELPS, PIKE, PULASKI, PUTNAM, RALLS, RANDOLPH, REYNOLDS, RIPLEY, ST. FRANCOIS, STE. GENEVIEVE, SCHUYLER, SCOTLAND, SCOTT, SHANNON, SHELBY, STODDARD, TEXAS, WASHINGTON, AND WAYNE COUNTIES

	Rates	Fringes
Power equipment operators:		
GROUP 1.....	\$ 33.24	28.75
GROUP 2.....	\$ 32.89	28.75
GROUP 3.....	\$ 32.69	28.75
GROUP 4.....	\$ 29.04	28.75

POWER EQUIPMENT OPERATORS CLASSIFICATIONS

GROUP 1: Asphalt finishing machine & trench widening spreader, asphalt plant console operator; autograder; automatic slipform paver; back hoe; blade operator - all types; boat operator tow; boiler two; central mix concrete plant operator; clam shell operator; concrete mixer paver; crane operator; derrick or derrick trucks; ditching machine; dozer operator; dragline operator; dredge booster pump; dredge engineman; dredge operator; drill cat with compressor mounted on cat; drilling or boring machine rotary self-propelled; highloader; hoisting engine 2 active drums; launchhammer wheel; locomotive operator standrad guage; mechanics and welders; mucking machine; piledriver operator; pitman crane operator; push cat operator; quad-trac; scoop operator; sideboom cats; skimmer scoop operator; trenching machine operator; truck crane, shovel operator.

GROUP 2: A-Frame; asphalt hot-mix silo; asphalt roller operator asphalt plant fireman (drum or boiler); asphalt plant man; asphalt plant mixer operator; backfiller operator; barber-greene loader; boat operator (bridge & dams); chip spreader; concrete mixer operator skip loader; concrete plant operator; concrete pump operator; dredge oiler; elevating graded operator; fork lift; grease fleet; hoisting engine one; locomotive operator narrow guage; multiple compactor; pavement breaker; powerbroom self-propelled; power shield; rooter; slip-form finishing machine; stumpcutter machine; side discharge concrete spreader; throttleman; tractor operator (over 50 hp); winch truck; asphalt roller operator; crusher operator.

GROUP 3: Spreader box operator, self-propelled not asphalt; tractor operator (50 h.p. or less); boilers one; chip spreader (front man); churn drill operator; compressor over 105 CFM 2-3 pumps 4" & over; 2-3 light plant 7.5 KWA or any combination thereof; clef plane operator; compressor maintenance operator 2 or 3; concrete saw operator (self-propelled); curb finishing mancine; distributor operator; finishing machine operator; flex plane operator; float operator; form grader operator; pugmill operator; riller operator other than high type asphalt; screening & washing plant operator; siphons & jets; subgrading machine operator; tank car heater (combination boiler & booster); ulmac, ulric or similar spreader; vibrating machine operator; hydrobroom.

GROUP 4: Oiler; grout machine; oiler driver; compressor over 105 CFM one; conveyor operator one; maintenance operator; pump 4" & over one.

FOOTNOTE: HOURLY PREMIUMS

Backhoe hydraulic, 2 cu. yds. or under Without oiler - \$2.00
 Certified Crane Operator - \$1.50;
 Certified Hazardous Material Operator \$1.50;
 Crane, climbing (such as Linden) - \$0.50;
 Crane, pile driving and extracting - \$0.50;
 Crane, with boom (including jib) over 100' from pin to pin
 add \$0.01 per foot to maximum of \$4.00;
 Crane, using rock socket tool - \$0.50;
 Derrick, diesel, gas or electric, hoisting material and
 erecting steel (150' or more above the ground) - \$0.50;
 Dragline, 7 cu. yds, and over - \$0.50;
 Hoist, three or more drums in use - \$0.50; Scoop, Tandem -
 \$0.50;
 Shovel, power - 7 cu. yds. or more - \$0.50;
 Tractor, tandem crawler - \$0.50;
 Tunnel, man assigned to work in tunnel or tunnel shaft -
 \$0.50;
 Wrecking, when machine is working on second floor or higher -
 \$0.50;

 ENGI0513-007 05/05/2022

ST. LOUIS CITY AND COUNTY

	Rates	Fringes
Power equipment operators:		
GROUP 1.....	\$ 38.36	28.93
GROUP 2.....	\$ 38.36	28.93
GROUP 3.....	\$ 37.06	28.93
GROUP 4.....	\$ 36.61	28.93

POWER EQUIPMENT OPERATORS CLASSIFICATIONS

GROUP 1: Backhoe, cable or hydraulic; cableway; crane crawler or truck; crane, hydraulic-truck or cruiser mounted 16 tons & over; crane locomotive; derrick, steam; derrick car & derrick boat; dragline; dredge; gradall, crawler or tire mounted; locomotive, gas, steam & other powers; pile driver, land or floating; scoop, skimmer; shovel, power (steam, gas, electric or other powers); switch boat; whirley.

GROUP 2: Air tugger w/air compressor; anchor-placing barge; asphalt spreader; atehy force feeder loader (self-propelled); backfilling machine; backhoe-loader; boat operator-push boat or tow boat (job site); boiler, high pressure breaking in period; boom truck, placing or erecting; boring machine, footing foundation; bull- float; cherry picker; combination concrete hoist & mixer (such as mixer mobile); compressor (when operator runs throttle); concrete breaker (truck or tractor mounted); concrete pump, such as pump-crete machine; concrete saw (self-propelled), concrete spreader; conveyor, large (not self-propelled), hoisting or moving brick and concrete into, or into and on floor level, one or both; crane, hydraulic-rough terrain, self-propelled; crane hydraulic-truck or cruiser mounted-under 16 tons; drilling machines, self-powered use for earth or rock drilling or boring (wagon drills nd any hand drills obtaining power from other sources including concrete breakers, jackhammers and barco equipment-no engineer required); elevating grader; engineman, dredge; excavator or powerbelt machine; finishing machine, self-propelled oscillating screed; forklift; grader, road with power blade; highlift. greaser; hoist, stack, hydro-hammer; loading machine (such as barber-greene); machanic, on job site; mixer, pipe wrapping machines; plant asphalt; plant, concrete producing or ready-mix job site; plant heating-job site; plant mixing-job site; plant power, generating-job site; pumps, two through six self-powered over 2""; pumps, electric submersible, two through six, over

4"; quad-track; roller, asphalt, top or sub-grade; scoop, tractor drawn; spreader box; sub-grader; tie tamper; tractor-crawler, or wheel type with or without power unit, power take-offs and attachments regardless of size; trenching machine; tunnel boring machine; vibrating machine automatic, automatic propelled; welding machines (gasoline or diesel) two through six; well drilling machine

GROUP 3: Conveyor, large (not self-propelled); conveyor, large (not self-propelled) moving brick and concrete distributing) on floor level; mixer two or more mixers of one bag capacity or less; air tugger w/plant air; boiler, for power or heating on construction projects; boiler, temporary; compressor (mounted on truck; curb finishing machine; ditch paving machine; elevator; endless chain hoist; form grader; hoist, one drum regardless of size; lad-a-vator; manlift; mixer, asphalt, over 8 cu. ft. capacity, without side loader, 2 bag capacity or more; mixer, with side loader, regardless of size; pug mill operator; pump, sump-self-powered, automatic controlled over 2" during use in connection with construction work; sweeper, street; welding machine, one over 400 amp.; winch operating from truck; scissor lift (used for hoisting); tractor, small wheel type 50 h.p. & under with grader blade & similar equipment; Oiler on dredge and on truck crane.

GROUP 4: Boat operator-outboard motor (job site); conveyor (such as con-vay-it) regardless of how used; sweeper, floor

HOURLY PREMIUMS:

Backhoe, hydraulic	
2 cu. yds. or under without oiler	\$2.00
Certified Crane Operator	1.50
Certified Hazardous Material Operator	1.50
Crane, climbing (such as Linden)	.50
Crane, pile driving and extracting	.50
Crane, with boom (including jib) over 100' (from pin to pin) add \$.01 per foot to maximum of	4.00
Crane, using rock socket tool	.50
Derrick, diesel, gas or electric, hoisting material and erecting steel (150' or more above ground)	.50
Dragline, 7 cu. yds. and over	.50
Hoist, three (3) or more drums in use	.50
Scoop, Tandem	.50
Shovel, power - 7 cu. yds. or more	.50
Tractor, tandem crawler	.50
Tunnel, man assigned to work in tunnel or tunnel shaft	.50
Wrecking, when machine is working on second floor or higher	.50

 * IRON0010-012 04/01/2021

Rates Fringes

Ironworkers:

ANDREW, BARTON, BENTON,
 CAMDEN, CEDAR, CHARITON,
 CHRISTIAN, COOPER, DADE,
 DALLAS, DAVIESS, DE KALB,
 GENTRY, GREENE, GRUNDY,
 HARRISON, HICKORY, HOLT,
 HOWARD, LACLEDE, LINN,
 LIVINGSTON, MERCER,
 MONITEAU, MORGAN, NODAWAY,
 PETTIS, POLK, PUTNAM,
 RANDLOPH, ST. CLAIR,
 SULLIVAN, TANEY, VERNON,
 WEBSTER, WRIGHT and WORTH

Counties and portions of
 ADAIR, BOONE, MACON,
 MILLER and RANDOLPH
 Counties.....\$ 31.50 31.99
 ATCHISON, BATES, BUCHANAN,
 CALDWELL, CARROLL, CASS,
 CLAY, CLINTON, HENRY,
 JACKSON, JOHNSON,
 LAFAYETTE, PETTIS, PLATTE,
 SALINE, AND RAY COUNTIES....\$ 34.50 31.99

IRON0321-002 08/01/2021

DOUGLAS, HOWELL and OZARK COUNTIES

	Rates	Fringes
Ironworker.....	\$ 23.00	19.61

IRON0396-004 08/04/2021

ST. LOUIS (City and County), ST. CHARLES, JEFFERSON, IRON,
 FRANKLIN, LINCOLN, WARREN, WASHINGTON, ST. FRANCOIS, STE.
 GENEVIEVE, and REYNOLDS Counties; and portions of MADISON,
 PERRY, BOLLINGER, WAYNE, and CARTER Counties

	Rates	Fringes
Ironworker.....	\$ 36.71	28.96

IRON0396-009 08/04/2021

AUDRAIN, CALLAWAY, COLE, CRAWFORD, DENT, GASCONADE, MARIES,
 MONTGOMERY, OSAGE, PHELPS, PIKE, PULASKI, TEXAS and WRIGHT
 Counties; and portions of BOONE, CAMDEN, DOUGLAS, HOWELL,
 LACLEDE, MILLER, MONROE, OREGON, SHANNON and RALLS Counties

	Rates	Fringes
Ironworker.....	\$ 32.24	28.96

IRON0577-005 08/01/2021

ADAIR, CLARK, KNOX, LEWIS, MACON, MARION, MONROE, RALLS,
SCHUYLER, SCOTLAND, AND SHELBY COUNTIES

	Rates	Fringes
Ironworker.....	\$ 28.00	24.85

IRON0584-004 06/01/2021

BARRY, JASPER, LAWRENCE, MCDONALD, NEWTON AND STONE Counties

	Rates	Fringes
Ironworkers:.....	\$ 26.25	15.35

IRON0782-003 08/01/2021

CAPE GIRARDEAU, MISSISSIPPI, NEW MADRID, SCOTT, & STODDARD
 Counties; and portions of BOLLINGER, BUTLER, CARTER, DUNKLIN,
 MADISON, PEMISCOT, PERRY, RIPLEY, and WAYNE Counties

	Rates	Fringes
Ironworkers: Locks, Dams, Bridges and		

other major work on the Mississippi and Ohio River only.....	\$ 35.13	28.27
All Other Work.....	\$ 29.34	24.12

LAB00042-003 03/02/2022

ST. LOUIS (City and County)

	Rates	Fringes
LABORER		
Plumber Laborer.....	\$ 35.80	16.77

LAB00042-005 03/02/2022

ST. LOUIS (City and County)

	Rates	Fringes
LABORER		
Dynamiter, Powderman.....	\$ 35.80	16.77
Laborers, Flaggers.....	\$ 35.80	16.77
Wrecking.....	\$ 35.80	16.77

* LAB00110-005 05/01/2022

Jefferson and Washington Counties

	Rates	Fringes
LABORER (Jefferson County)		
GROUP 1.....	\$ 34.49	15.42
GROUP 2.....	\$ 35.09	15.42
LABORER (Washington County)		
GROUP 1.....	\$ 32.10	15.42
GROUP 2.....	\$ 32.10	15.42

LABORERS CLASSIFICATIONS

GROUP 1 - General laborer-flagman, carpenter tenders; salamander Tenders; Dump Man; Ticket Takers; loading trucks under bins, hoppers, and conveyors; track man; cement handler; dump man on earth fill; georgie buggy man; material batch hopper man; spreader on asphalt machine; material mixer man (except on manholes); coffer dams; riprap pavers rock, block or brick; scaffolds over ten feet not self-supported from ground up; skip man on concrete paving; wire mesh setters on concrete paving; all work in connection with sewer, water, gas, gasoling, oil, drainage pipe, conduit pipe, tile and duct lines and all other pipe lines; power tool operator; all work in connection with hydraulic or general dredging operations; form setters, puddlers (paving only); straw blower nozzle man; asphalt plant platform man; chuck tender; crusher feeder; men handling creosote ties or creosote materials; men working with and handling epoxy material; topper of standing trees; feeder man on wood pulverizers, board and willow mat weavers and cabelee tiers on river work; deck hands; pile dike and revetment work; all laborers working on underground tunnels less than 25 ft. where compressed air is not used; abutment and pier hole men working six (6) ft. or more below ground; men working in coffer dams for bridge piers and footing in the river; barco tamper; jackson or any other similar tamp; cutting torch man; liners, curb, gutters, ditch lines; hot mastic kettlemen; hot tar applicator; hand blade operator; mortar men or brick or block manholes; rubbing concrete, air tool operator under 65 lbs.; caulker and lead man; chain or concrete saw under 15 h.p.; signal Gan; Guard rail and sign erectors.

GROUP 2 - Skilled laborers - Vibrator man; asphalt raker; head pipe layer on sewer work; batterboard man on pipe and ditch work; cliff scalers working from bosun's chairs; scaffolds or platforms on dams or power plants over 10 ft. high; air tool operator over 65 lbs.; stringline man on concrete paving; sandblast man; laser beam man; wagon drill; churn drill; air track drill and all other similar type drills, gunite nozzle man; pressure grout man; screed man on asphalt; concrete saw 15 h.p. and over; grade checker; strigline man on electronic grade control; manhole builder; dynamite man; powder man; welder; tunnel man; waterblaster - 1000 psi or over; asbestos and/or hazardous waste removal and/or disposal

LAB00579-005 05/01/2022

	Rates	Fringes
LABORER (ANDREW, ATCHISON, BUCHANAN, CALDWELL, CLINTON, DAVIESS, DEKALB, GENTRY, GRUNDY, HARRISON, HOLT, LIVINGSTON, MERCER, NODAWAY and WORTH COUNTIES.)		
GROUP 1.....	\$ 28.29	16.34
GROUP 2.....	\$ 28.64	16.34
LABORER (BARRY, BARTON, BATES, BENTON, CAMDEN, CARROLL, CEDAR, CHRISTIAN, DADE, DALLAS, DOUGLAS, GREENE, HENRY. HICKORY, JASPER, JOHNSON, LACLEDE, LAWRENCE, MCDONALD, MORGAN, NEWTON, OZARK, PETTIS, POLK, ST. CLAIR, SALINE, STONE, TANEY, VERNON, WEBSTER and WRIGHT COUNTIES)		
GROUP 1.....	\$ 27.28	15.55
GROUP 2.....	\$ 27.83	15.55
LABORER (LAFAYETTE COUNTY)		
GROUP 1.....	\$ 28.83	15.80
GROUP 2.....	\$ 29.18	15.80

LABORERS CLASSIFICATIONS

GROUP 1: General Laborers - Carpenter tenders; salamander tenders; loading trucks under bins; hoppers & conveyors; track men & all other general laborers; air tool operator; cement handler-bulk or sack; dump man on earth fill; georgie buggy man; material batch hopper man; material mixer man (except on manholes); coffer dams; riprap pavers - rock, block or brick; signal man; scaffolds over ten feet not self-supported from ground up; skipman on concrete paving; wire mesh setters on concrete paving; all work in connection with sewer, water, gas, gasoline, oil drainage pipe, conduit pipe, tile and duct lines and all other pipe lines; power tool operator, all work in connection with hydraulic or general dredging operations; puddlers (paving only); straw blower nozzle man; asphalt plant platform man; chuck tender; crusher feeder; men handling creosote ties or creosote materials; men working with and handling epoxy material or materials (where special protection is required); rubbing concrete; topper of standing trees; batter board man on pipe and ditch work; feeder man on wood pulverizers; board and willow mat weavers and cable tiers on river work; deck hands; pile dike and revetment work; all laborers working on underground tunnels less than 25 feet where compressed air is not used; abutment and pier hole men working six (6) feet or more below ground; men working in coffer dams for bridge piers and footings in the river; ditchliners; pressure groutmen; caulker; chain or

concrete saw; cliffscalers working from scaffolds, bosuns' chairs or platforms on dams or power plants over (10) feet above ground; mortarmen on brick or block manholes; toxic and hazardous waste work.

GROUP 2: Skilled Laborers - Head pipe layer on sewer work; laser beam man; Jackson or any other similar tamp; cutting torch man; form setters; liners and stringline men on concrete paving, curb, gutters; hot mastic kettleman; hot tar applicator; sandblasting and gunite nozzlemen; air tool operator in tunnels; screed man on asphalt machine; asphalt raker; barco tamper; churn drills; air track drills and all similar drills; vibrator man; stringline man for electronic grade control; manhole builders-brick or block; dynamite and powder men; grade checker.

 * LAB00660-004 05/01/2022

Clark, Knox, Lewis, Lincoln, Marion, Montgomery, Pike, Ralls, Scotland, Shelby, St Charles and Warren Counties

	Rates	Fringes
LABORER		
GROUP 1.....	\$ 32.10	15.42
GROUP 2.....	\$ 32.10	15.42

LABORERS CLASSIFICATIONS

GROUP 1 - General laborer-flagman, carpenter tenders; salamander Tenders; Dump Man; Ticket Takers; loading trucks under bins, hoppers, and conveyors; track man; cement handler; dump man on earth fill; georgie buggy man; material batch hopper man; spreader on asphalt machine; material mixer man (except on manholes); coffer dams; riprap pavers rock, block or brick; scaffolds over ten feet not self-supported from ground up; skip man on concrete paving; wire mesh setters on concrete paving; all work in connection with sewer, water, gas, gasoling, oil, drainage pipe, conduit pipe, tile and duct lines and all other pipe lines; power tool operator; all work in connection with hydraulic or general dredging operations; form setters, puddlers (paving only); straw blower nozzle man; asphalt plant platform man; chuck tender; crusher feeder; men handling creosote ties or creosote materials; men working with and handling epoxy material; topper of standing trees; feeder man on wood pulverizers, board and willow mat weavers and cabelee tiers on river work; deck hands; pile dike and revetment work; all laborers working on underground tunnels less than 25 ft. where compressed air is not used; abutement and pier hole men working six (6) ft. or more below ground; men working in coffer dams for bridge piers and footing in the river; barco tamper; jackson or any other similar tamp; cutting torch man; liners, curb, gutters, ditch lines; hot mastic kettlemen; hot tar applicator; hand blade operator; mortar men or brick or block manholes; rubbing concrete, air tool operator under 65 lbs.; caulker and lead man; chain or concrete saw under 15 h.p.; signal Gan; Guard rail and sign erectors.

GROUP 2 - Skilled laborers - Vibrator man; asphalt raker; head pipe layer on sewer work; batterboard man on pipe and ditch work; cliff scalers working from bosun's chairs; scaffolds or platforms on dams or power plants over 10 ft. high; air tool operator over 65 lbs.; stringline man on concrete paving; sandblast man; laser beam man; wagon drill; churn drill; air track drill and all other similar type drills, gunite nozzle man; pressure grout man; screed man on asphalt; concrete saw 15 h.p. and over; grade

checker; strigline man on electronic grade control; manhole builder; dynamite man; powder man; welder; tunnel man; waterblaster - 1000 psi or over; asbestos and/or hazardous waste removal and/or disposal

 * LAB00662-001 05/01/2022

Callaway, Cole, Miller and Moniteau Counties

	Rates	Fringes
LABORER		
GROUP 1.....	\$ 32.10	15.42
GROUP 2.....	\$ 32.10	15.42

LABORERS CLASSIFICATIONS

GROUP 1 - General laborer-flagman, carpenter tenders; salamander Tenders; Dump Man; Ticket Takers; loading trucks under bins, hoppers, and conveyors; track man; cement handler; dump man on earth fill; georgie buggy man; material batch hopper man; spreader on asphalt machine; material mixer man (except on manholes); coffer dams; riprap pavers rock, block or brick; scaffolds over ten feet not self-supported from ground up; skip man on concrete paving; wire mesh setters on concrete paving; all work in connection with sewer, water, gas, gasoling, oil, drainage pipe, conduit pipe, tile and duct lines and all other pipe lines; power tool operator; all work in connection with hydraulic or general dredging operations; form setters, puddlers (paving only); straw blower nozzle man; asphalt plant platform man; chuck tender; crusher feeder; men handling creosote ties or creosote materials; men working with and handling epoxy material; topper of standing trees; feeder man on wood pulverizers, board and willow mat weavers and cabelee tiers on river work; deck hands; pile dike and revetment work; all laborers working on underground tunnels less than 25 ft. where compressed air is not used; abutement and pier hole men working six (6) ft. or more below ground; men working in coffer dams for bridge piers and footing in the river; barco tamper; jackson or any other similar tamp; cutting torch man; liners, curb, gutters, ditch lines; hot mastic kettlemen; hot tar applicator; hand blade operator; mortar men or brick or block manholes; rubbing concrete, air tool operator under 65 lbs.; caulker and lead man; chain or concrete saw under 15 h.p.; signal Gan; Guard rail and sign erectors.

GROUP 2 - Skilled laborers - Vibrator man; asphalt raker; head pipe layer on sewer work; batterboard man on pipe and ditch work; cliff scalers working from bosun's chairs; scaffolds or platforms on dams or power plants over 10 ft. high; air tool operator over 65 lbs.; stringline man on concrete paving; sandblast man; laser beam man; wagon drill; churn drill; air track drill and all other similar type drills, guniting nozzle man; pressure grout man; screed man on asphalt; concrete saw 15 h.p. and over; grade checker; strigline man on electronic grade control; manhole builder; dynamite man; powder man; welder; tunnel man; waterblaster - 1000 psi or over; asbestos and/or hazardous waste removal and/or disposal

 LAB00663-002 04/01/2022

CASS, CLAY, JACKSON, PLATTE AND RAY COUNTIES

	Rates	Fringes
LABORER		

GROUP 1.....	\$ 33.05	16.81
GROUP 2.....	\$ 34.26	16.81

LABORERS CLASSIFICATIONS

GROUP 1: General laborers, Carpenter tenders, salamander tenders, loading trucks under bins, hoppers and conveyors, track men and all other general laborers, air tool operator, cement handler (bulk or sack), chain or concrete saw, deck hands, dump man on earth fill, Georgie Buggies man, material batch hopper man, scale man, material mixer man (except on manholes), coffer dams, abutments and pier hole men working below ground, riprap pavers rock, black or brick, signal man, scaffolds over ten feet not self-supported from ground up, skipman on concrete paving, wire mesh setters on concrete paving, all work in connection with sewer,water, gas, gasoling, oil, drainage pipe, conduit pipe, tile and duct lines and all other pipelines, power tool operator, all work in connection with hydraulic or general dredging operations, straw blower nozzleman,asphalt plant platform man, chuck tender, crusher feeder, men handling creosote ties on creosote materials, men working with and handling epoxy material or materials (where special protection is required), topper of standing trees, batter board man on pipe and ditch work, feeder man on wood pulverizers, board and willow mat weavers and cable tiers on river work, deck hands, pile dike and revetment work, all laborers working on underground tunnels less than 25 feet where compressed air is not used, abutment and pier hole men working six (6) feet or more below ground, men working in coffer dams for bridge piers and footings in the river, ditchliners, pressure groutmen, caulker and chain or concrete saw, cliffscalers working from scaffolds, bosuns' chairs or platforms on dams or power plants over (10) feet above ground, mortarmen on brick or block manholes, signal man.

GROUP 2: Skilled Laborer - spreader or screed man on asphalt machine, asphalt raker, grade checker, vibrator man, concrete saw over 5 hp., laser beam man, barco tamper, jackson or any other similar tamp, wagon driller, churn drills, air track drills and other similar drills, cutting torch man, form setters, liners and stringline men on concrete paving, curb, gutters and etc., hot mastic kettleman, hot tar applicator, hand blade operators, mortar men on brick or block manholes, sand blasting and gunnite nozzle men, rubbing concrete, air tool operator in tunnels, head pipe layer on sewer work, manhole builder (brick or block), dynamite and powder men.

 * LABO0840-011 05/01/2022

Crawford, Dent, Franklin, Gasconade, Howell, Maries, Oregon, Osage, Phelps, Pulaski, Shannon and Texas Counties

	Rates	Fringes
LABORER		
GROUP 1.....	\$ 32.10	15.42
GROUP 2.....	\$ 32.10	15.42

LABORERS CLASSIFICATIONS

GROUP 1 - General laborer-flagman, carpenter tenders; salamander Tenders; Dump Man; Ticket Takers; loading trucks under bins, hoppers, and conveyors; track man; cement handler; dump man on earth fill; georgie buggy man; material batch hopper man; spreader on asphalt machine; material mixer man (except on manholes); coffer dams; riprap pavers rock, block or brick; scaffolds over ten feet

not self-supported from ground up; skip man on concrete paving; wire mesh setters on concrete paving; all work in connection with sewer, water, gas, gasoling, oil, drainage pipe, conduit pipe, tile and duct lines and all other pipe lines; power tool operator; all work in connection with hydraulic or general dredging operations; form setters, puddlers (paving only); straw blower nozzle man; asphalt plant platform man; chuck tender; crusher feeder; men handling creosote ties or creosote materials; men working with and handling epoxy material; topper of standing trees; feeder man on wood pulverizers, board and willow mat weavers and cabelee tiers on river work; deck hands; pile dike and revetment work; all laborers working on underground tunnels less than 25 ft. where compressed air is not used; abutment and pier hole men working six (6) ft. or more below ground; men working in coffer dams for bridge piers and footing in the river; barco tamper; jackson or any other similar tamp; cutting torch man; liners, curb, gutters, ditch lines; hot mastic kettlemen; hot tar applicator; hand blade operator; mortar men or brick or block manholes; rubbing concrete, air tool operator under 65 lbs.; caulker and lead man; chain or concrete saw under 15 h.p.; signal Gan; Guard rail and sign erectors.

GROUP 2 - Skilled laborers - Vibrator man; asphalt raker; head pipe layer on sewer work; batterboard man on pipe and ditch work; cliff scalers working from bosun's chairs; scaffolds or platforms on dams or power plants over 10 ft. high; air tool operator over 65 lbs.; stringline man on concrete paving; sandblast man; laser beam man; wagon drill; churn drill; air track drill and all other similar type drills, gunite nozzle man; pressure grout man; screed man on asphalt; concrete saw 15 h.p. and over; grade checker; strigline man on electronic grade control; manhole builder; dynamite man; powder man; welder; tunnel man; waterblaster - 1000 psi or over; asbestos and/or hazardous waste removal and/or disposal

 * LAB00955-012 05/01/2022

Adair, Audrain, Boone, Chariton, Cooper, Howard, Linn, Macon, Monroe, Putnam, Randolph, Schuyler and Sullivan Counties

	Rates	Fringes
LABORER		
GROUP 1.....	\$ 32.10	15.42
GROUP 2.....	\$ 32.10	15.42

LABORERS CLASSIFICATIONS

GROUP 1 - General laborer-flagman, carpenter tenders; salamander Tenders; Dump Man; Ticket Takers; loading trucks under bins, hoppers, and conveyors; track man; cement handler; dump man on earth fill; georgie buggie man; material batch hopper man; spreader on asphalt machine; material mixer man (except on manholes); coffer dams; riprap pavers rock, block or brick; scaffolds over ten feet not self-supported from ground up; skip man on concrete paving; wire mesh setters on concrete paving; all work in connection with sewer, water, gas, gasoling, oil, drainage pipe, conduit pipe, tile and duct lines and all other pipe lines; power tool operator; all work in connection with hydraulic or general dredging operations; form setters, puddlers (paving only); straw blower nozzle man; asphalt plant platform man; chuck tender; crusher feeder; men handling creosote ties or creosote materials; men working with and handling epoxy material; topper of standing trees; feeder man on wood pulverizers, board and willow mat

weavers and cabelee tiers on river work; deck hands; pile dike and revetment work; all laborers working on underground tunnels less than 25 ft. where compressed air is not used; abutement and pier hole men working six (6) ft. or more below ground; men working in coffer dams for bridge piers and footing in the river; barco tamper; jackson or any other similar tamp; cutting torch man; liners, curb, gutters, ditch lines; hot mastic kettlemen; hot tar applicator; hand blade operator; mortar men or brick or block manholes; rubbing concrete, air tool operator under 65 lbs.; caulker and lead man; chain or concrete saw under 15 h.p.; signal Gan; Guard rail and sign erectors.

GROUP 2 - Skilled laborers - Vibrator man; asphalt raker; head pipe layer on sewer work; batterboard man on pipe and ditch work; cliff scalers working from bosun's chairs; scaffolds or platforms on dams or power plants over 10 ft. high; air tool operator over 65 lbs.; stringline man on concrete paving; sandblast man; laser beam man; wagon drill; churn drill; air track drill and all other similar type drills, gunite nozzle man; pressure grout man; screed man on asphalt; concrete saw 15 h.p. and over; grade checker; strigline man on electronic grade control; manhole builder; dynamite man; powder man; welder; tunnel man; waterblaster - 1000 psi or over; asbestos and/or hazardous waste removal and/or disposal

 * LAB01104-005 05/01/2022

Bollinger, Butler, Cape Girardeau, Carter, Dunklin, Iron, Madison, Mississippi, New Madrid, Pemiscot, Perry, Reynolds, Ripley, Scott, St Francois, Ste Genevieve, Stoddard and Wayne Counties

	Rates	Fringes
LABORER		
GROUP 1.....	\$ 32.10	15.42
GROUP 2.....	\$ 32.10	15.42

LABORERS CLASSIFICATIONS

GROUP 1 - General laborer-flagman, carpenter tenders; salamander Tenders; Dump Man; Ticket Takers; loading trucks under bins, hoppers, and conveyors; track man; cement handler; dump man on earth fill; georgie buggy man; material batch hopper man; spreader on asphalt machine; material mixer man (except on manholes); coffer dams; riprap pavers rock, block or brick; scaffolds over ten feet not self-supported from ground up; skip man on concrete paving; wire mesh setters on concrete paving; all work in connection with sewer, water, gas, gasoling, oil, drainage pipe, conduit pipe, tile and duct lines and all other pipe lines; power tool operator; all work in connection with hydraulic or general dredging operations; form setters, puddlers (paving only); straw blower nozzle man; asphalt plant platform man; chuck tender; crusher feeder; men handling creosote ties or creosote materials; men working with and handling epoxy material; topper of standing trees; feeder man on wood pulverizers, board and willow mat weavers and cabelee tiers on river work; deck hands; pile dike and revetment work; all laborers working on underground tunnels less than 25 ft. where compressed air is not used; abutement and pier hole men working six (6) ft. or more below ground; men working in coffer dams for bridge piers and footing in the river; barco tamper; jackson or any other similar tamp; cutting torch man; liners, curb, gutters, ditch lines; hot mastic kettlemen; hot tar applicator; hand blade operator; mortar men or

brick or block manholes; rubbing concrete, air tool operator under 65 lbs.; caulker and lead man; chain or concrete saw under 15 h.p.; signal Gan; Guard rail and sign erectors.

GROUP 2 - Skilled laborers - Vibrator man; asphalt raker; head pipe layer on sewer work; batterboard man on pipe and ditch work; cliff scalers working from bosun's chairs; scaffolds or platforms on dams or power plants over 10 ft. high; air tool operator over 65 lbs.; stringline man on concrete paving; sandblast man; laser beam man; wagon drill; churn drill; air track drill and all other similar type drills, gunite nozzle man; pressure grout man; screed man on asphalt; concrete saw 15 h.p. and over; grade checker; strigline man on electronic grade control; manhole builder; dynamite man; powder man; welder; tunnel man; waterblaster - 1000 psi or over; asbestos and/or hazardous waste removal and/or disposal

PAIN0002-002 09/01/2007

CLARK, FRANKLIN, JEFFERSON, LEWIS, LINCOLN, MARION, PIKE, RALLS, ST. CHARLES, ST. LOUIS (CITY & COUNTY), AND WARREN COUNTIES

	Rates	Fringes
Painters:		
Brush and Roller; Taper.....	\$ 28.61	10.24
High work over 60 feet.....	\$ 29.11	10.24
Lead Abatement.....	\$ 29.36	10.24
Pressure Roller; High work under 60 ft.....	\$ 28.86	10.24
Spray & Abrasive Blasting; Water Blasting (Over 5000 PSI).....	\$ 30.61	10.24
Taper (Ames Tools & Bazooka).....	\$ 30.21	10.24

PAIN0002-006 04/01/2020

ADAIR, AUDRAIN, BOONE, CALLAWAY, CHARITON, COLE, GASCONADE, HOWARD, KNOX, LINN, MACON, MONROE, MONTGOMERY, OSAGE, PUTNAM, RANDOLPH, SCHUYLER, SCOTLAND, SHELBY AND SULLIVAN COUNTIES and the City of Booneville.

	Rates	Fringes
Painters:		
Bridges, Dams, Locks or Powerhouses.....	\$ 26.64	13.98
Brush and Roll; Taping, Paperhanging.....	\$ 24.64	13.98
Epoxy or Any Two Part Coating; Sandblasting; Stage or other Aerial Work - Platforms over 50 feet high; Lead Abatement.....	\$ 25.64	13.98
Spray; Structural Steel (over 50 feet).....	\$ 24.64	13.98
Tapers using Ames or Comparable Tools.....	\$ 25.39	13.98

PAIN0003-004 04/01/2019

CASS, CLAY, CLINTON, JACKSON, JOHNSON, LAFAYETTE, PLATTE & RAY COUNTIES

Rates Fringes

Painters:

Bridgeman; Lead Abatement;		
Sandblast; Storage Bin &		
Tanks.....	\$ 33.41	17.76
Brush & Roller.....	\$ 30.54	17.76
Drywall.....	\$ 31.74	17.76
Paper Hanger.....	\$ 31.04	17.76
Stageman; Beltman;		
Steelman; Elevator Shaft;		
Bazooka, Boxes and Power		
Sander; Sprayman; Dipping...	\$ 32.41	17.76
Steeplejack.....	\$ 36.98	17.76

PAIN003-011 04/01/2019

BATES, BENTON, CALDWELL, CARROLL, COOPER, DAVIESS, GRUNDY,
HARRISON, HENRY, LIVINGSTON, MERCER, MONITEAU, MORGAN, PETTIS &
SALINE COUNTIES

Rates Fringes

Painters:

Bridgeman; Lead Abatement;		
Sandblast; Storage Bin &		
Tanks.....	\$ 26.73	17.76
Brush & Roller.....	\$ 24.43	17.76
Drywall.....	\$ 25.39	17.76
Paper Hanger.....	\$ 24.83	17.76
Stageman; Beltman;		
Steelman; Elevator Shaft;		
Bazooka, Boxes and Power		
Sander; Sprayman; Dipping...	\$ 26.35	17.76
Steeplejack.....	\$ 29.58	17.76

PAIN023-001 04/01/2012

BARRY, BARTON, CEDAR, CHRISTIAN, DADE, DALLAS, DOUGLAS, GREENE,
HICKORY, HOWELL, JASPER, LAWRENCE, MCDONALD, NEWTON, OZARK,
POLK, ST. CLAIR, STONE, TANEY, VERNON, WEBSTER, and WRIGHT
COUNTIES

Rates Fringes

Painters:

Finisher.....	\$ 20.18	11.33
Painter.....	\$ 19.75	11.76
Sandblaster, High Man,		
Spray Man, Vinyl Hanger,		
Tool Operator.....	\$ 21.18	11.33

PAIN1265-003 04/01/2022

CAMDEN, CRAWFORD, DENT, LACLEDE, MARIES, MILLER, PHELPS,
PULASKI AND TEXAS COUNTIES

Rates Fringes

Painters:

Brush and Roller.....	\$ 31.28	14.58
Floor Work.....	\$ 32.28	14.58
Lead Abatement.....	\$ 32.28	14.58
Spray.....	\$ 32.28	14.58
Structural Steel,		
Sandblasting and All Tank		
Work.....	\$ 33.28	14.58
Taping, Paperhanging.....	\$ 32.28	14.58

PAIN1292-002 09/01/2021

BOLLINGER, BUTLER, CAPE GIRARDEAU, CARTER, DUNKLIN, MISSISSIPPI, NEW MADRID, OREGON, PEMISCOT, PERRY, REYNOLDS, RIPLEY, SCOTT, SHANNON, STODDARD and WAYNE COUNTIES

	Rates	Fringes
Painters:		
Bridges, Stacks & Tanks.....	\$ 33.46	14.53
Brush & Roller.....	\$ 27.96	14.53
Spray & Abrasive Blasting; Waterblasting (over 5000 PSI).....	\$ 29.96	14.53

Height Rates (All Areas):
Over 60 ft. \$0.50 per hour.
Under 60 ft. \$0.25 per hour.

PAIN1292-003 09/01/2021

IRON, MADISON, ST. FRANCOIS, STE. GENEVIEVE and WASHINGTON COUNTIES

	Rates	Fringes
Painters:		
Bridges, Stacks & Tanks.....	\$ 33.46	14.53
Brush & Roller.....	\$ 27.96	14.53
Spray & Abrasive Blasting; Waterblasting (Over 5000 PSI).....	\$ 29.96	14.53

Height Rates (All Areas):
Over 60 ft. \$0.50 per hour
Under 60 ft. \$0.25 per hour.

PAIN2012-001 04/01/2020

ANDREW, ATCHISON, BUCHANAN, DE KALB, GENTRY, HOLT, NODAWAY & WORTH COUNTIES

	Rates	Fringes
Painters:		
Brush & Roller.....	\$ 32.91	17.86
Sandblaster.....	\$ 34.41	17.86
Steeplejack.....	\$ 37.98	17.86

PLAS0518-006 03/01/2022

BARRY, BARTON, CEDAR, CHRISTIAN, DADE, DALLAS, DOUGLAS, GREENE, HICKORY, JASPER, LACLEDE, LAWRENCE, MCDONALD, NEWTON, OZARK, POLK, ST. CLAIR, STONE, TANEY, VERNON, WEBSTER, AND WRIGHT COUNTIES

	Rates	Fringes
CEMENT MASON/CONCRETE FINISHER...	\$ 25.77	12.43

PLAS0518-007 04/01/2022

CASS (Richards-Gebaur AFB only), CLAY, JACKSON, PLATTE AND RAY COUNTIES

	Rates	Fringes
Cement Masons:.....	\$ 35.12	18.30

PLAS0518-011 04/01/2022

ANDREW, ATCHISON, BATES, BUCHANNAN, CLINTON, DEKALB, GENTRY,
HENRY, HOLT, JOHNSON, LAFAYETTE, NODAWAY & WORTH COUNTIES

	Rates	Fringes
CEMENT MASON/CONCRETE FINISHER...	\$ 34.93	20.50

PLAS0527-001 04/01/2021

	Rates	Fringes
CEMENT MASON FRANKLIN, LINCOLN AND WARREN COUNTIES.....	\$ 34.79	19.58
JEFFERSON, ST. CHARLES COUNTIES AND ST. LOUIS (City and County).....	\$ 35.96	19.56

PLAS0527-004 06/01/2021

CRAWFORD, DENT, IRON, MADISON, MARION, PHELPS, PIKE, PULASKI,
RALLS, REYNOLDS, ST. FRANCOIS, STE. GENEVIEVE, SHANNON, TEXAS,
WASHINGTON COUNTIES

	Rates	Fringes
CEMENT MASON.....	\$ 30.30	19.48

PLAS0908-001 05/01/2021

BOLLINGER, BUTLER, CAPE GIRARDEAU, CARTER, DUNKLIN, HOWELL,
MISSISSIPPI, NEW MADRID, OREGON, PEMISCOT, PERRY, RIPLEY,
SCOTT, STODDARD, AND WAYNE COUNTIES

	Rates	Fringes
CEMENT MASON.....	\$ 30.30	17.53

PLAS0908-005 05/01/2021

BENTON, CALDWELL, CALLAWAY, CAMDEN, CARROLL, COLE, DAVIESS,
GASCONADE, GRUNDY, HARRISON, LIVINGSTON, MACON, MARIES, MERCER,
MILLER, MONTGOMERY, MORGAN, OSAGE, PETTIS & SALINE COUNTIES

	Rates	Fringes
CEMENT MASON.....	\$ 30.30	17.53

PLUM0008-003 06/01/2021

CASS, CLAY, JACKSON, JOHNSON, AND PLATTE COUNTIES

	Rates	Fringes
Plumbers.....	\$ 49.43	23.29

PLUM0008-017 06/01/2021

BATES, BENTON, CARROLL, HENRY, LAFAYETTE, MORGAN, PETTIS, RAY,
ST. CLAIR, SALINE AND VERNON COUNTIES

	Rates	Fringes
Plumbers.....	\$ 49.43	23.29

PLUM0045-003 08/01/2021

ANDREW, ATCHISON, BUCHANAN, CALDWELL, CLINTON, DAVIESS, DEKALB,
GENTRY, HARRISON, HOLT, NODAWAY AND WORTH COUNTIES

	Rates	Fringes
Plumbers and Pipefitters.....	\$ 39.80	25.05

PLUM0178-003 11/01/2021

BARRY, CEDAR, CHRISTIAN, DADE, DALLAS, DOUGLAS, GREENE,
HICKORY, LACLEDE, LAWRENCE, POLK, STONE, TANEY, WEBSTER AND
WRIGHT COUNTIES

	Rates	Fringes
Plumbers and Pipefitters.....	\$ 34.25	15.32

PLUM0178-006 11/01/2021

BARTON, JASPER, MCDONALD AND NEWTON COUNTIES

	Rates	Fringes
Plumbers and Pipefitters		
Projects \$750,000 & under...	\$ 31.28	15.32
Projects over \$750,000.....	\$ 34.25	15.32

PLUM0533-004 06/01/2021

BATES, BENTON, CARROLL, CASS, CLAY, HENRY, HICKORY, JACKSON,
JOHNSON, LAFAYETTE, MORGAN, PETTIS, PLATTE, RAY, SALINE, ST.
CLAIR AND VERNON COUNTIES

	Rates	Fringes
Pipefitters.....	\$ 49.98	22.95

PLUM0562-004 07/01/2021

ADAIR, AUDRAIN, BOLLINGER, BOONE, BUTLER, CALLAWAY,CAMDEN, CAPE
GIRARDEAU,CARTER, CHARITON, CLARK, COLE, COOPER, CRAWFORD,
DENT, DUNKLIN, FRANKLIN, GASCONADE, GRUNDY, HOWARD, HOWELL,
IRON, JEFFERSON, KNOX, LEWIS, LINCOLN, LINN, LIVINGSTON, MACON,
MADISON, MARIES, MARION, MERCER, MILLER, MISSISSIPPI, MONITEAU,
MONROE, MONTGOMERY, NEW MADRID, OREGON, OSAGE, PEMISCOTT,
PERRY, PHELPS, PIKE, PULASKI, PUTNAM, RALLS, RANDOLPH,
REYNOLDS, RIPLEY, ST. CHARLES, ST.FRANCOIS, STE. GENEVIEVE, ST.
LOUIS, SCHUYLER, SCOTLAND, SCOTT, SHANNON, SHELBY, STODDARD,
SULLIVAN, TEXAS, WARREN, WASHINGTON,AND WAYNE COUNTIES.

	Rates	Fringes
Plumbers and Pipefitters		
Mechanical Contracts		
including all piping and		
temperature control work		
\$7.0 million & under.....	\$ 43.16	21.49
Mechanical Contracts		
including all piping and		
temperature control work		
over \$7.0 million.....	\$ 45.10	27.85

PLUM0562-016 07/01/2021

CAMDEN, COLE, CRAWFORD, FRANKLIN, JEFFERSON, MARIES, MILLER, MONITEAU, OSAGE, PHELPS, PULASKI, ST. CHARLES, ST. LOUIS (City and County), WARREN and WASHINGTON COUNTIES

	Rates	Fringes
Plumbers		
Mechanical Contracts including all piping and temperature control work \$7.0 million & under.....	\$ 43.16	21.49
Mechanical Contracts including all piping and temperature control work over \$7.0 million.....	\$ 45.10	27.85

TEAM0013-001 05/01/2022

	Rates	Fringes
Truck drivers (ADAIR, BUTLER, CLARK, DUNKIN, HOWELL, KNOX, LEWIS, OREGON, PUTNAM, RIPLEY, SCHUYLER AND SCOTLAND COUNTIES)		
GROUP 1.....	\$ 32.44	14.75
GROUP 2.....	\$ 32.60	14.75
GROUP 3.....	\$ 32.59	14.75
GROUP 4.....	\$ 32.71	14.75
Truck drivers (AUDRAIN, BOLLINGER, BOONE, CALLAWAY, CAPE GIRARDEAU, CARTER, COLE, CRAWFORD, DENT, GASCONADE, IRON, MACON, MADISON, MARIES, MARION, MILLER, MISSISSIPPI, MONROE, MONTGOMERY, NEW MADRID, OSAGE, PEMISCOT, PERRY, PHELPS, PIKE, PULASKI, RALLS, REYNOLDS, ST. FRANCOIS, STE. GENEVIEVE, SCOTT, SHANNON, SHELBY, STODDARD, TEXAS, WASHINGTON AND WAYNE COUNTIES)		
GROUP 1.....	\$ 33.17	14.75
GROUP 2.....	\$ 33.33	14.75
GROUP 3.....	\$ 33.32	14.75
GROUP 4.....	\$ 33.44	14.75
Truck drivers (FRANKLIN, JEFFERSON and ST. CHARLES COUNTIES)		
GROUP 1.....	\$ 35.53	14.75
GROUP 2.....	\$ 35.64	14.75
GROUP 3.....	\$ 35.68	14.75
GROUP 4.....	\$ 35.75	14.75
Truck drivers (LINCOLN and WARREN COUNTIES)		
GROUP 1.....	\$ 35.18	14.75
GROUP 2.....	\$ 34.29	14.75
GROUP 3.....	\$ 35.33	14.75
GROUP 4.....	\$ 34.40	14.75

TRUCK DRIVERS CLASSIFICATIONS:

GROUP 1: Flat Bed Trucks, Single Axle; Station Wagons; Pickup Trucks; Material Trucks, Single Axle; Tank Wagon, Single Axle

GROUP 2: Agitator and Transit Mix Trucks

GROUP 3: Flat Bed Trucks, Tandem Axle; Articulated Dump Trucks; Material Trucks, Tandem Axle; Tank Wagon, Tandem Axle

GROUP 4: Semi and/or Pole Trailers; Winch, Fork & Steel Trucks; Distributor Drivers and Operators; Tank Wagon, Semi-Trailer; Insley Wagons, Dumpsters, Half-Tracks, Speedace, Euclids and other similar equipment; A-Frame and Derrick Trucks; Float or Low Boy

TEAM0056-001 05/01/2020

	Rates	Fringes
Truck drivers (ANDREW, BARTON, BATES, BENTON, CALDWELL, CAMDEN, CARROLL, CEDAR, CHARITON, CHRISTIAN, CLINTON, COOPER, DADE, DALLAS, DAVIESS, DEKALB, DOUGLAS, GREENE, HENRY, HICKORY, HOWARD, JASPER, LACLEDE, LAWRENCE, LINN, LIVINGSTON, MONITEAU, MORGAN, NEWTON, PETTIS, POLK, RANDOLPH, ST. CLAIR, SALINE, VERNON, WEBSTER AND WRIGHT COUNTIES)		
GROUP 1.....	\$ 31.37	14.25
GROUP 2.....	\$ 31.53	14.25
GROUP 3.....	\$ 31.52	14.25
GROUP 4.....	\$ 31.64	14.25

Truck drivers: (ATCHISON, BARRY, GENTRY, GRUNDY, HARRISON, HOLT, MCDONALD, MERCER, NODAWAY, OZARK, STONE, SULLIVAN, TANEY AND WORTH COUNTIES)		
GROUP 1.....	\$ 30.64	14.25
GROUP 2.....	\$ 30.80	14.25
GROUP 3.....	\$ 30.79	14.25
GROUP 4.....	\$ 30.91	14.25

Truck drivers; (BUCHANAN, JOHNSON AND LAFAYETTE COUNTIES)		
GROUP 1.....	\$ 32.58	14.25
GROUP 2.....	\$ 32.69	14.25
GROUP 3.....	\$ 32.73	14.25
GROUP 4.....	\$ 32.80	14.25

TRUCK DRIVER CLASSIFICATIONS

GROUP 1: Flat bed trucks single axle; station wagons; pickup trucks; material trucks single axle; tank wagons single axle.

GROUP 2: Agitator and transit mix-trucks.

GROUP 3: Flat bed trucks tandem axle; articulated dump trucks; material trucks tandem axle; tank wagons tandem axle.

GROUP 4: Semi and/or pole trailers; winch, fork & steel trucks; distributor drivers & operators; tank wagons semi-trailer; insley wagons, dumpsters, half-tracks, speedace, euclids & other similar equipment; A-frames and derrick trucks; float or low boy.

TEAM0245-001 03/26/2012

BARRY, BARTON, CAMDEN, CEDAR, CHRISTIAN, DALLAS, DENT, DOUGLAS, GREENE, HICKORY, HOWELL, JASPER, LACLEDE, LAWRENCE, MCDONALD, MILLER, NEWTON, OZARK, PHELPS, POLK, PULASKI, SHANNON, STONE, TANEY, TEXAS, VERNON, WEBSTER AND WRIGHT COUNTIES

Rates Fringes

Truck drivers:

Traffic Control Service		
Driver.....	\$ 20.45	0.00

PAID HOLIDAYS: New Year's Day, Decoration Day, July 4th, Labor Day, Thanksgiving Day, Christmas Day, employee's birthday and 2 personal days.

TEAM0541-001 04/01/2022

CASS, CLAY, JACKSON, PLATTE AND RAY COUNTIES

Rates Fringes

Truck drivers:

GROUP 1.....	\$ 34.71	16.75
GROUP 2.....	\$ 34.14	16.75
GROUP 3.....	\$ 33.62	16.75

TRUCK DRIVERS CLASSIFICATIONS

GROUP 1: Mechanics and Welders, Field; A-Frame Low Boy-Boom ruck Driver.

GROUP 2: Articulated Dump Truck; Insley Wagons: Dump Trucks, Excavating, 5 cu yds and over; Dumpsters; Half-Tracks: Speedace: Euclids & similar excavating equipment Material trucks, Tandem Two teams; Semi-Trailers; Winch trucks-Fork trucks; Distributor Drivers and Operators; Agitator and Transit Mix; Tank Wagon Drivers, Tandem or Semi; One Team; Station Wagons; Pickup Trucks; Material Trucks, Single Axle; Tank Wagon Drivers, Single Axle

GROUP 3: Oilers and Greasers - Field

TEAM0682-002 05/01/2017

ST LOUIS CITY AND COUNTY

Rates Fringes

Truck drivers:

GROUP 1.....	\$ 33.30	13.79+a+b+c+d
GROUP 2.....	\$ 33.50	13.79+a+b+c+d
GROUP 3.....	\$ 33.60	13.79+a+b+c+d

- a. PENSION: 5/1/2012 - \$182.20 per week.
- b. HAZMAT PREMIUM: If Hazmat certification on a job site is required by a state or federal agency or requested by project owner or by the employer, employees on that job site shall receive \$1.50 premium pay.

TRUCK DRIVERS CLASSIFICATIONS

GROUP 1 - Pick-up trucks; forklift, single axle; flatbed trucks; job site ambulance, and trucks or trailers of a water level capacity of 11.99 cu. yds. or less

GROUP 2 - Trucks or trailers of a water level capacity of 12.0 cu yds. up to 22.0 cu yds. including euclids, speedace and similar equipment of same capacity and compressors

GROUP 3 - Trucks or trailers of a water level capacity of 22.0 cu. yds & over including euclids, speedace & all floats, flatbed trailers, boom trucks, winch trucks, including small trailers, farm wagons tilt-top trailers, field offices, tool trailers, concrete pumps, concrete conveyors & gasoline tank trailers and truck mounted mobile concrete mixers

FOOTNOTE FOR TRUCK DRIVERS:

c. PAID HOLIDAYS: Christmas Day, Independence Day, Labor Day, Memorial Day, Veterans Day, New Years Day, Thanksgiving Day

d. PAID VACATION: 3 days paid vacation for 600 hours of service in any one contract year; 4 days paid vacation for 800 hours of service in any one contract year; 5 days paid vacation for 1,000 hours of service in any one contract year. When such an employee has completed 3 years of continuous employment with the same employer and then works the above required number of hours, he shall receive double the number of days of vacation specified above. When such an employee has completed 10 years of continuous employment with the same employer and then works the above required number of hours, he shall receive triple the number of days of vacation specified above. When such an employee has completed 15 years of continuous employment with the same employer and then works the above required number of hours, he shall receive 4 times the number of days of vacation specified above.

WELDERS - Receive rate prescribed for craft performing operation to which welding is incidental.

=====
Note: Executive Order (EO) 13706, Establishing Paid Sick Leave for Federal Contractors applies to all contracts subject to the Davis-Bacon Act for which the contract is awarded (and any solicitation was issued) on or after January 1, 2017. If this contract is covered by the EO, the contractor must provide employees with 1 hour of paid sick leave for every 30 hours they work, up to 56 hours of paid sick leave each year. Employees must be permitted to use paid sick leave for their own illness, injury or other health-related needs, including preventive care; to assist a family member (or person who is like family to the employee) who is ill, injured, or has other health-related needs, including preventive care; or for reasons resulting from, or to assist a family member (or person who is like family to the employee) who is a victim of, domestic violence, sexual assault, or stalking. Additional information on contractor requirements and worker protections under the EO is available at <https://www.dol.gov/agencies/whd/government-contracts>.

Unlisted classifications needed for work not included within the scope of the classifications listed may be added after award only as provided in the labor standards contract clauses (29CFR 5.5 (a) (1) (ii)).

The body of each wage determination lists the classification and wage rates that have been found to be prevailing for the cited type(s) of construction in the area covered by the wage determination. The classifications are listed in alphabetical order of ""identifiers"" that indicate whether the particular

rate is a union rate (current union negotiated rate for local), a survey rate (weighted average rate) or a union average rate (weighted union average rate).

Union Rate Identifiers

A four letter classification abbreviation identifier enclosed in dotted lines beginning with characters other than ""SU"" or ""UAVG"" denotes that the union classification and rate were prevailing for that classification in the survey. Example: PLUM0198-005 07/01/2014. PLUM is an abbreviation identifier of the union which prevailed in the survey for this classification, which in this example would be Plumbers. 0198 indicates the local union number or district council number where applicable, i.e., Plumbers Local 0198. The next number, 005 in the example, is an internal number used in processing the wage determination. 07/01/2014 is the effective date of the most current negotiated rate, which in this example is July 1, 2014.

Union prevailing wage rates are updated to reflect all rate changes in the collective bargaining agreement (CBA) governing this classification and rate.

Survey Rate Identifiers

Classifications listed under the ""SU"" identifier indicate that no one rate prevailed for this classification in the survey and the published rate is derived by computing a weighted average rate based on all the rates reported in the survey for that classification. As this weighted average rate includes all rates reported in the survey, it may include both union and non-union rates. Example: SULA2012-007 5/13/2014. SU indicates the rates are survey rates based on a weighted average calculation of rates and are not majority rates. LA indicates the State of Louisiana. 2012 is the year of survey on which these classifications and rates are based. The next number, 007 in the example, is an internal number used in producing the wage determination. 5/13/2014 indicates the survey completion date for the classifications and rates under that identifier.

Survey wage rates are not updated and remain in effect until a new survey is conducted.

Union Average Rate Identifiers

Classification(s) listed under the UAVG identifier indicate that no single majority rate prevailed for those classifications; however, 100% of the data reported for the classifications was union data. EXAMPLE: UAVG-OH-0010 08/29/2014. UAVG indicates that the rate is a weighted union average rate. OH indicates the state. The next number, 0010 in the example, is an internal number used in producing the wage determination. 08/29/2014 indicates the survey completion date for the classifications and rates under that identifier.

A UAVG rate will be updated once a year, usually in January of each year, to reflect a weighted average of the current negotiated/CBA rate of the union locals from which the rate is based.

WAGE DETERMINATION APPEALS PROCESS

1.) Has there been an initial decision in the matter? This can be:

- * an existing published wage determination
- * a survey underlying a wage determination

- * a Wage and Hour Division letter setting forth a position on a wage determination matter
- * a conformance (additional classification and rate) ruling

On survey related matters, initial contact, including requests for summaries of surveys, should be with the Wage and Hour National Office because National Office has responsibility for the Davis-Bacon survey program. If the response from this initial contact is not satisfactory, then the process described in 2.) and 3.) should be followed.

With regard to any other matter not yet ripe for the formal process described here, initial contact should be with the Branch of Construction Wage Determinations. Write to:

Branch of Construction Wage Determinations
 Wage and Hour Division
 U.S. Department of Labor
 200 Constitution Avenue, N.W.
 Washington, DC 20210

2.) If the answer to the question in 1.) is yes, then an interested party (those affected by the action) can request review and reconsideration from the Wage and Hour Administrator (See 29 CFR Part 1.8 and 29 CFR Part 7). Write to:

Wage and Hour Administrator
 U.S. Department of Labor
 200 Constitution Avenue, N.W.
 Washington, DC 20210

The request should be accompanied by a full statement of the interested party's position and by any information (wage payment data, project description, area practice material, etc.) that the requestor considers relevant to the issue.

3.) If the decision of the Administrator is not favorable, an interested party may appeal directly to the Administrative Review Board (formerly the Wage Appeals Board). Write to:

Administrative Review Board
 U.S. Department of Labor
 200 Constitution Avenue, N.W.
 Washington, DC 20210

4.) All decisions by the Administrative Review Board are final.

=====

END OF GENERAL DECISIO"