

**NOTES:**  
 Cost of S-bars will be considered completely covered by the contract unit price for the Slab.  
 S-bars are not listed in the bill of reinforcing.  
 (1) End panels shall be dimensioned 1/2" min. to 1-1/2" max. from the inside face of diaphragm.  
 (2) S-bars shown are bottom steel in slab between panels and used with squared end panels only.  
 (3) Adjustment in the slab thickness, preformed fiber expansion joint material or polystyrene bedding material thickness, or grade will be necessary if the girder camber after erection differs from plan camber by more than the % of dead load deflection due to the weight of structural steel. No payment will be made for additional labor or materials for the adjustment.  
 (4) All panel support pads shall be glued to the girder. When support thickness exceeds 1-1/2 inches, the pads shall be glued top and bottom. The glue used shall be the type recommended by the panel support pads manufacturer.  
 (5) Use #3-P3 bars if panel is skewed 45° or greater.  
 (6) S-bars shown are used with skewed end panels, or skewed end panels of square structures only. The #5 S-bars shall extend the width of slab (2'-6" lap if necessary) or to within 3 inches of expansion device assembly.  
 (7) Any strand 2'-0" or shorter shall have a #4 reinforcing bar on each side of it, centered between strands. Strands 2'-0" or shorter may then be deboned at the fabricator's option.  
 (8) Extend S-bars 18 inches beyond the front face of end bents only.  
 (9) Minimum reinforcement steel length shall be 2'-0".  
 (10) #3-P2 bars near edge of panel at bottom (under strands).

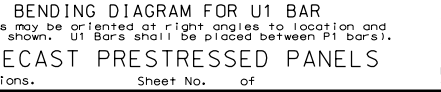
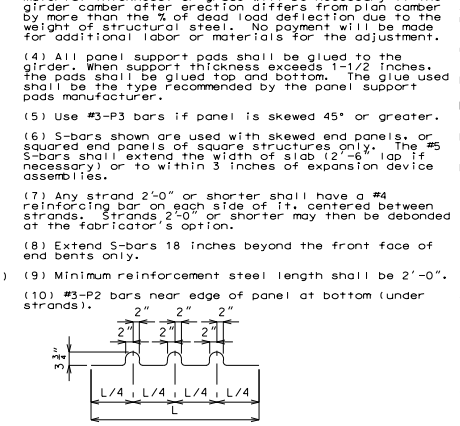
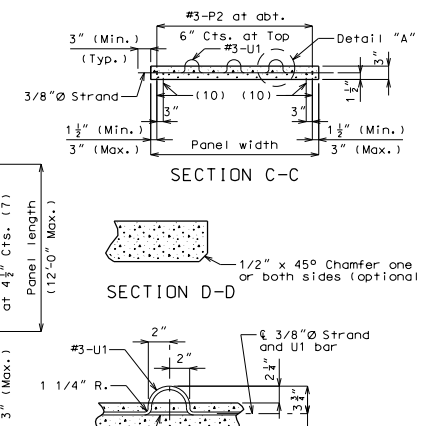
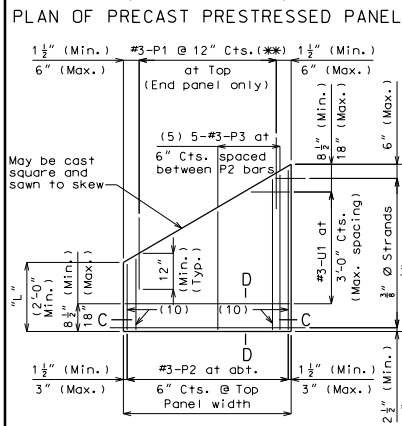

**DETAILS OF PRECAST PRESTRESSED PANELS**  
 (U1 Bars may be oriented at right angles to location and spacing shown. U1 Bars shall be placed between P1 bars).  
 Note: This drawing is not to scale. Follow dimensions. Sheet No. of

**GENERAL NOTES:**  
**PRESTRESSED PANELS:**  
 Concrete for prestressed panels shall be Class A-1 with f'c = 6,000 psi, f'ci = 4,000 psi.  
 The top surface of all panels shall receive a scored finish with a depth of scoring of 1/8" perpendicular to the prestressing strands in the panels.  
 Prestressing tendons shall be high-tensile strength uncoated seven-wire low-relaxation strands for prestressed concrete in accordance with ASTM A420 M 253 Grade 270, with nominal diameter of strand = 3/8" and nominal area = 0.085 sq. in. and minimum ultimate strength = 22.95 kips (270 ksi). Larger strands may be used with the same spacing and initial tension.  
 Initial prestressing force = 17.2 kips/strand.  
 The method and sequence of releasing the strands shall be shown on the shop drawings.  
 Suitable anchorage devices for lifting panels may be cast in panels, provided the devices are shown on the shop drawings and approved by the engineer. Panel lengths shall be determined by the contractor and shown on the shop drawings.  
 When squared end panels are used at skewed bents, the skewed portion shall be cast full depth. No separate payment will be made for additional concrete and reinforcing required.  
 Minimum preformed fiber expansion joint material or polystyrene bedding material thickness shall be 1 inch, except over splice plates where minimum thickness shall be 1/4 inch. When material is less than 1/2" thick, a 3/8" or 1/2" plate, the width of material at the joint shall be the same width as panel on splice. Thicker material may be used on one or both sides of the girder to reduce cost-in-place concrete thickness to within tolerances. No more than 2" total thickness shall be used.  
 The same thickness of material shall be used under any one edge of any panel except at splices, and the maximum change in thickness between adjacent panels shall be 1/4 inch to correct for variations from girder camber diagram. The polystyrene bedding material may be cut to match haunch height above top of flange.  
 Support from diaphragm forms is required under the optional skewed end until cast-in-place concrete has reached 3,000 psi compressive strength.  
 Edges of panels shall be uniformly seated on the joint filler before slab reinforcement is placed.  
**REINFORCING STEEL:**  
 All dimensions are out to out.  
 Minimum clearance to reinforcing steel shall be 1-1/2", unless otherwise shown.  
 Hooks and bends shall be in accordance with the CRSI Manual of Standard Practice for Detailing Reinforced Concrete Structures, Stirrup and Tie Dimensions.  
 Actual lengths are measured along centerline of bar to the nearest inch.  
 The prestressed panel quantities are not included in the table of estimated quantities for slab.  
 If U1 bars interfere with placement of slab steel, U1 loops may be bent over, as necessary, to clear slab steel.  
 Welded wire fabric or welded deformed bar mats providing a minimum area of reinforcing perpendicular to strands of 0.22 sq. in./ft., with spacing parallel to strands sufficient to insure proper handling, may be used in lieu of the #3-P2 bars shown. Wire or bar diameter shall not be larger than 0.375 inches. The above alternative reinforcement criteria may be used in lieu of the #3-P3 bars, when required, and placed over a width not less than 2 feet.  
 The reinforcing steel shall be tied securely to the 3/8" Ø strands with the following maximum spacing in each direction:  
 #3-P2 bars at 16 inches.  
 Welded wire fabric or welded deformed bar mats at 2'-0".  
 Tie the #3-U1 bars to the #3-P2 bars, to the welded wire fabric or the welded deformed bar mats at about 3'-0" centers.  
 All reinforcement other than prestressing strands shall be epoxy coated.  
 Precast panels may be in contact with stirrup reinforcing in diaphragms.

DATE PREPARED 1/24/2012		STATE MO	
ROUTE BR		SHEET NO. *	
COUNTY *		JOB NO. *	
CONTRACT ID. *		PROJECT NO. *	
BRIDGE NO. SPN 1		DESCRIPTION	
DATE		COMMISSION	
MISSOURI HIGHWAY AND TRANSPORTATION		105 WEST CAPITOL JEFFERSON CITY, MO 65102 1-888-ASK-MODOT (1-888-275-6636)	