

PART SECTION NEAR DRAIN

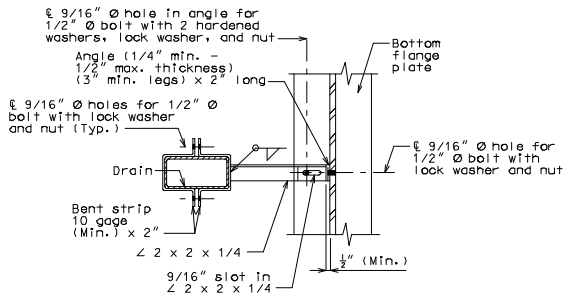

PART SECTION SHOWING BRACKET ASSEMBLY

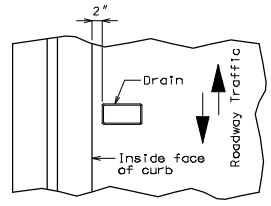

PART PLAN OF SLAB AT DRAIN

DETAILS OF DRAINS TRANSVERSE TO ROADWAY

SLAB DRAIN DETAILS

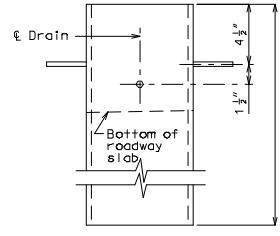

ELEVATION OF DRAIN

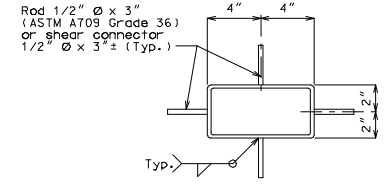

PLAN OF DRAIN

Notes:

Slab drains may be fabricated of either 1/4" welded sheets of ASTM A709 Grade 36 steel or from 1/4" structural steel tubing ASTM A500 or A501.

Slab drain bracket assembly shall be ASTM A709 Grade 36 steel.

Outside dimensions of drains are 8" x 4".

Locate drains in slab by dimensions shown in Part Section Near Drain.

Shift reinforcing steel in field where necessary to clear drains.

The drains and bracket assembly shall be galvanized in accordance with ASTM A123.

All bolts, hardened washers, lock washers and nuts shall be galvanized in accordance with ASTM A153.

Shop drawings will not be required for the slab drains and the bracket assembly.

The bolt hole for the bracket assembly attachment shall be located on the plate girder shop drawings.

DATE PREPARED 07/28/2008	
ROUTE *	STATE MO
DISTRICT BR	SHEET NO. *
COUNTY *	
JOB NO. *	
CONTRACT ID. *	
PROJECT NO. *	
BRIDGE NO. DRA 6	
DESCRIPTION	
DATE	
MISSOURI HIGHWAYS AND TRANSPORTATION COMMISSION	
105 WEST CAPITOL JEFFERSON CITY, MO 65102 1-888-ASK-MODOT (1-888-275-6636)	