

Concrete for prestressed girders shall be Class A-1 with $f'_c = 8000$ psi and $f'_ci = 6500$ psi.

(+) indicates prestressing strand.

Use strands with an initial prestress force of _____ kips.

Prestressing tendons shall be uncoated, seven-wire, low-relaxation strands, 0.6 inch diameter in accordance with AASHTO M 203, Grade 270. Pretensioned members shall be in accordance with Sec 1023.

Girders shall be lifted by devices designed by the fabricator.

** At the contractor's option the location for bent-up strands may be varied from that shown. The total number of bent-up strands shall not be changed. One strand tie bar is required for each layer of bent-up strands except at end bents which require one bar on the bottom layer of strands only. No additional payment will be made if additional strand tie bars are required.

*** Girder top flange shall be steel troweled to a smooth finish for 8" at the edges, as shown. Bond breaker shall be applied to this region only. The center portion shall be rough finished by scarifying the surface transversely with a wire brush, and no laitance shall remain on the surface.

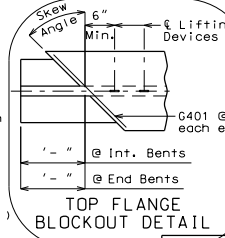

BILL OF REINFORCING STEEL - EACH GIRDER			
NO.	SIZE & MAX. #	ACTUAL LENGTH	SHAPE
XXX	3 G301	2'-11 3/4"	15
2	4 G401	XX'-XX"	20
XXX	X G402	5'-1"	20

BENDING DIAGRAM	
SHAPE 15 (G301)	16" x 16" x 3/8" (typ. dia.)
SHAPE 20 (G401)	3'-10 1/2" / cos (skew angle)
SHAPE 20 (G402)	

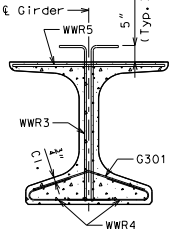
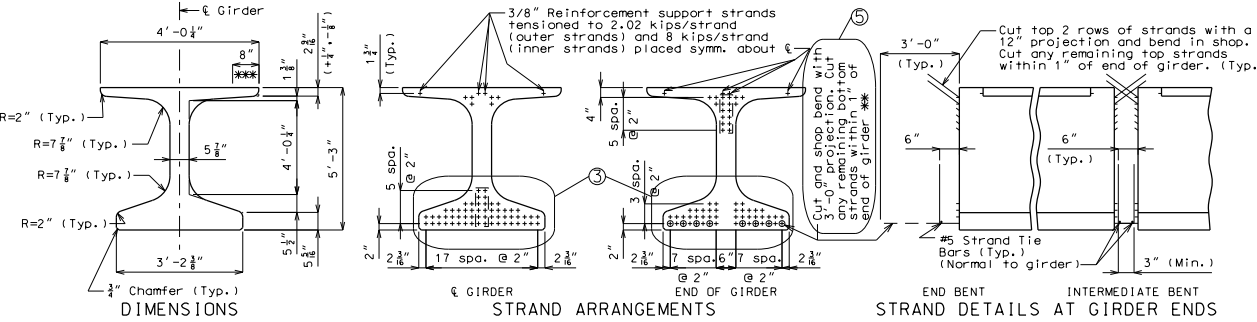

WELDED WIRE REINFORCEMENT (WWR4 & WWR5 as shown in Welded Wire Bending Diagrams)												
SPAN NO.	WWR1			WWR2			WWR3			WWR5		
	BAR SIZE	S1	S2	BAR SIZE	S1	S2	BAR SIZE	S1	S2	S3	S4	
X	X	X"	X'-X"	X"	X	X"	X'-X"	X"	X	X"	X'-X"	X"
X	X	X"	X'-X"	X"	X	X"	X'-X"	X"	X	X"	X'-X"	X"

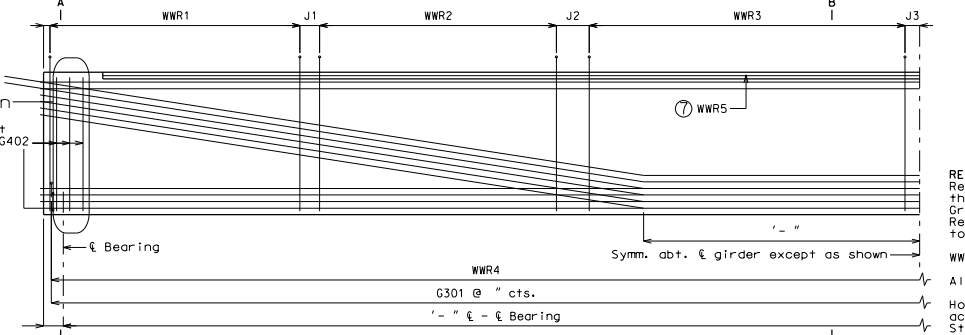
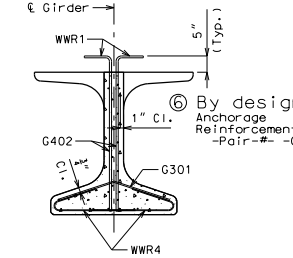
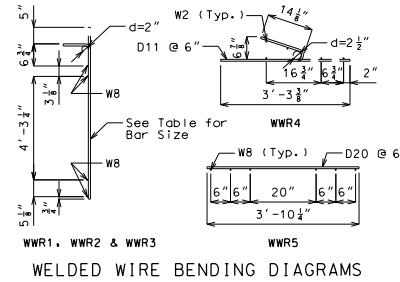

REINFORCING STEEL NOTES:
 Reinforcing steel shall conform to the requirements of AASHTO M 31, Grade 60. Welded Wire Reinforcement (WWR) shall conform to the requirements of AASHTO M 221.
 WWR shall not be epoxy coated.
 All dimensions are out to out.
 Hooks and bends shall be in accordance with the CRSI Manual of Standard Practice for Detailing Reinforced Concrete Structures, Stirrup and Tie Dimensions.
 Minimum clearance to reinforcing shall be 1", unless otherwise shown.
 Actual bar lengths are measured along centerline of bar.

Cost of 3/4" coil tie rods placed in diaphragms will be considered completely covered by the contract unit price for Prestressed Concrete NU-Girder.

Coil ties shall be held in place in the forms by slotted wire-setting studs projecting through forms. Studs are to be left in place or replaced with temporary plugs until girders are erected, then replaced by coil tie rods.

For location of coil inserts at slab drains, see Sheet No. _____

The 1 1/2" holes shall be cast in the web for steel intermediate diaphragms.

Drilling is not allowed. For details of diaphragms, see Sheet No. _____

For Girder Camber Diagram, see Sheet No. _____

Alternate bar reinforcing steel details are provided and may be used. Some type of reinforcing steel shall be used for all girders in all spans.

* Length of coil tie rods at exterior girders at end bents = _____

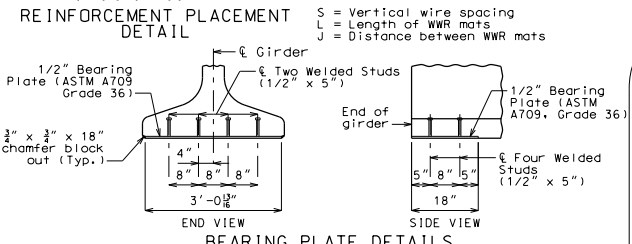
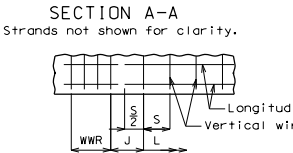

Galvanize the 1/2" bearing plate (ASTM A709 Grade 36) in accordance with ASTM A123.

Cost of furnishing, galvanizing, and installing the 1/2" bearing plate (ASTM A709 Grade 36) and welded studs in the prestressed girder will be considered completely covered by the contract unit price for Prestressed Concrete NU-Girder.

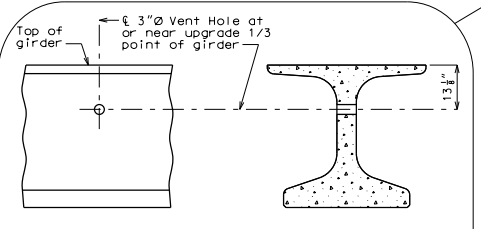

Place vent holes at or near upgrade 1/3 point of girders and clear reinforcing steel or strands by 1 1/2" minimum and steel intermediate diaphragm bolt connections by 6" minimum.

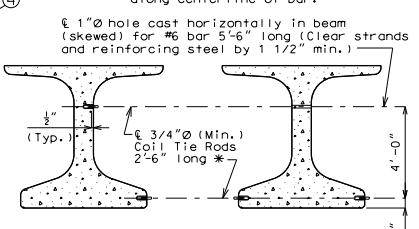

1 1/2" hole cast horizontally in beam (skewed) for #6 bar 5'-6" long (Clear strands and reinforcing steel by 1 1/2" min.)

EXTERIOR GIRDS AT INT. BENTS

EXTERIOR GIRDS AT END BENTS
 INTERIOR GIRDS AT ALL BENTS

THIS MEDIA SHOULD NOT BE CONSIDERED A CERTIFIED DOCUMENT.
 DATE PREPARED 3/5/2012
 ROUTE STATE MO
 DISTRICT BR SHEET NO. *
 COUNTY *
 JOB NO. *
 CONTRACT ID. *
 BRIDGE NO. NU 63
 MISSOURI HIGHWAYS AND TRANSPORTATION COMMISSION
 105 WEST CAPITOL JEFFERSON CITY, MO 65102
 1-888-ASK-MODOT (1-888-275-6636)