

Concrete for prestressed girders shall be Class A-1 with $f'_c = 8000$ psi and $f'_ci = 6500$ psi.

(+) indicates prestressing strand.

Use strands with an initial prestress force of _____ kips.

Prestressing tendons shall be uncoated, seven-wire, low-relaxation strands, 0.6 inch diameter in accordance with AASHTO M 203, Grade 270. Pretensioned members shall be in accordance with Sec 1029.

Girders shall be lifted by devices designed by the fabricator.

At the contractor's option the location for bent-up strands may be varied from that shown. The total number of bent-up strands shall not be changed. One strand tie bar is required for each layer of bent-up strands except at end bents which require one bar on the bottom layer of strands only. No additional payment will be made if additional strand tie bars are required.

Girder top flange shall be steel troweled to a smooth finish for 8" at the edges, as shown. Bond breaker shall be applied to this region only. The center portion shall be rough finished by scarifying the surface transversely with a wire brush, and no laitance shall remain on the surface.

Reinforcement support strands tensioned to 2.02 kips/strand (outer strands) and 8 kips/strand (inner strands) placed symm. about _____

Cut and shop bend with 3'-0" projection. Cut any remaining bottom strands within 1" of end of girder.

Cut top 2 rows of strands with a 12" projection and bend in shop. Cut any remaining top strands within 1" of end of girder.

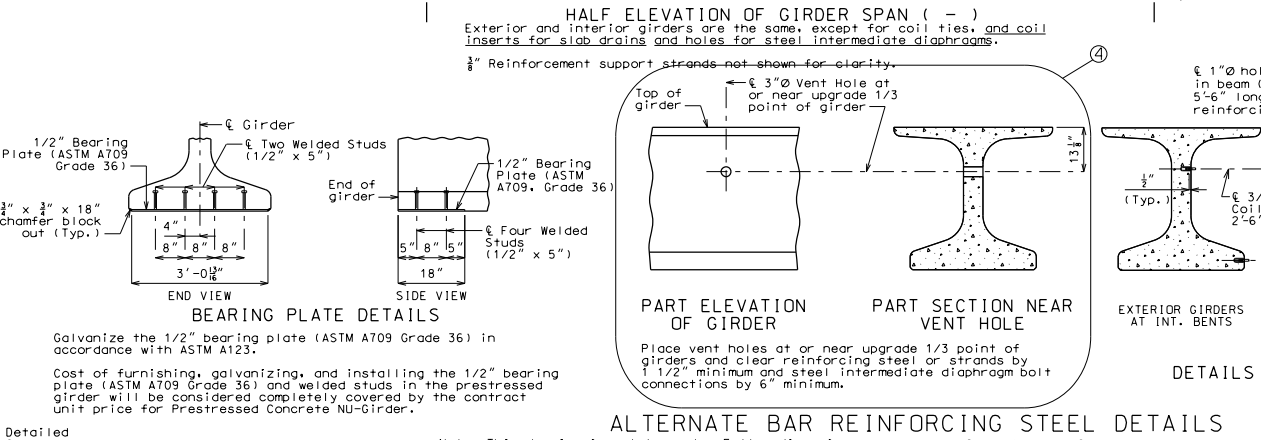
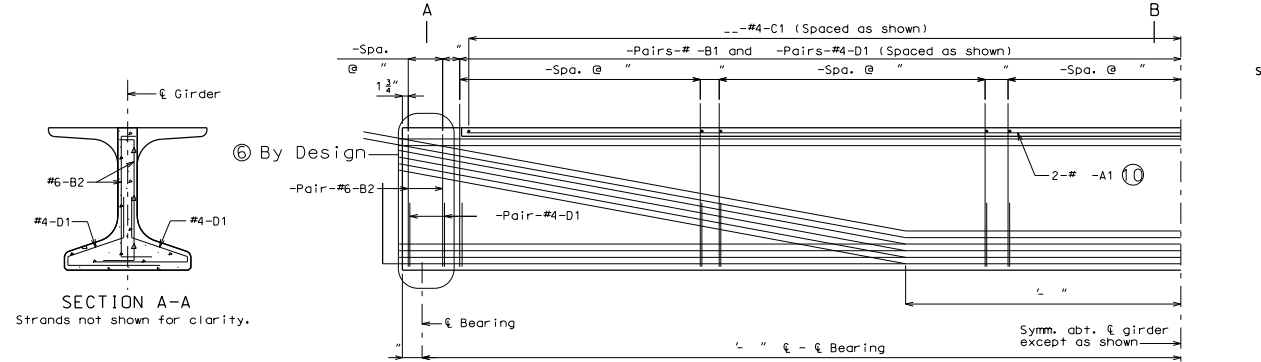
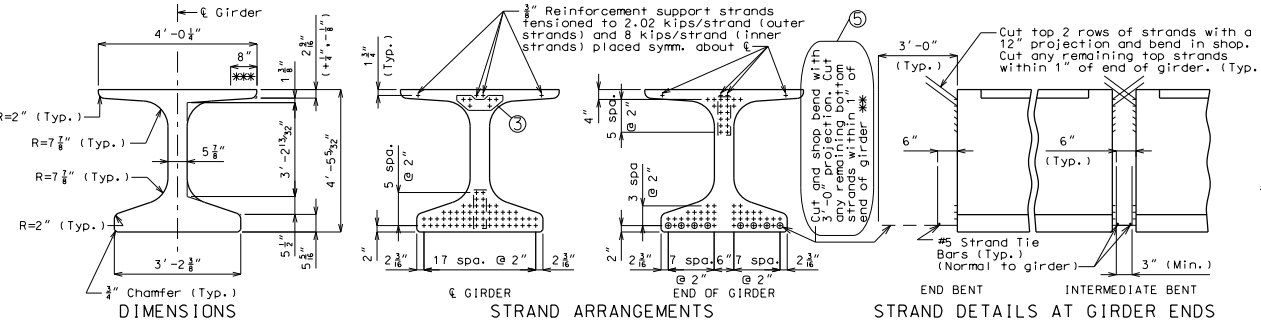

BILL OF REINFORCING STEEL - EACH GIRDER				BENDING DIAGRAM	
NO.	SIZE	ACTUAL LENGTH	SHAPE	SHAPE	REMARKS
XXX	X A1	XX'-XX"	20	SHAPE 20 (C1)	
XXX	X B1	5'-9"	19	SHAPE 20 (C2)	C1/COS(skew)
XXX	6 B2	5'-2"	19	SHAPE 9	
XXX	4 C1	3'-10"	20	4'-9 1/4" B1	
2	4 C2	X'-XX"	20	4'-3 3/8" B2	
XXX	4 D1	4'-2"	9	Top 100	
				SHAPE 19	

All dimensions are out to out.
 Hooks and bends shall be in accordance with the CRSI Manual of Standard Practice for Detailing Reinforced Concrete Structures, Stirrup and Tie Dimensions.
 Actual lengths are measured along centerline of bar to the nearest inch.
 Minimum clearance to reinforcing shall be 1".
 All reinforcement shall be Grade 60.
 The two D1 bars may be furnished as one bar at the fabricator's option.
 All B1 bars shall be epoxy coated.
 Splay or cut C1 bars near top flange blockout for skewed blockout.

At the fabricator's option WWR5 welded wire may be substituted for the C1 and A1 bars.

Cost of 3/4" coil tie rods placed in diaphragms will be considered completely covered by the contract unit price for Prestressed Concrete NU-Girder.
 Coil ties shall be held in place in the forms by slotted wire-setting-studs projecting through forms. Studs are to be left in place or replaced with temporary plugs until girders are erected, then replaced by coil tie rods.
 For location of coil inserts at slab drains, see Sheet No. & .
 For location of coil ties, see Sheets No. & .
 The 1 1/2" holes shall be cast in the web for steel intermediate diaphragms. Drilling is not allowed.
 For details of diaphragms see Sheet No. & .
 For Girder Camber Diagram, see Sheet No. & .
 * Length of coil tie rods at exterior girders at end bents = _____ .
 Alternate bar reinforcing steel details are provided and may be used. The same type of reinforcing steel shall be used for all girders in all spans.

"THIS MEDIA SHOULD NOT BE CONSIDERED A CERTIFIED DOCUMENT."

DATE PREPARED: 3/5/2012
 ROUTE: MO
 DISTRICT: BR SHEET NO. *
 COUNTY: COUNTY
 JOB NO.: *
 CONTRACT ID.: *
 PROJECT NO.: *
 BRIDGE NO.: NU 53

MISSOURI HIGHWAYS AND TRANSPORTATION COMMISSION

105 WEST CAPITOL JEFFERSON CITY, MO 65102 1-888-ASK-MODOT (1-888-275-6636)

MODOT

REV. 1