

ROUTE	STATE	DISTRICT	SHEET NO.
*	MO	BR	*
JOB NO. *			
CONTRACT ID.			
PROJECT NO.			
COUNTY *			
			DATE

"THIS MEDIA SHOULD NOT BE CONSIDERED A CERTIFIED DOCUMENT."

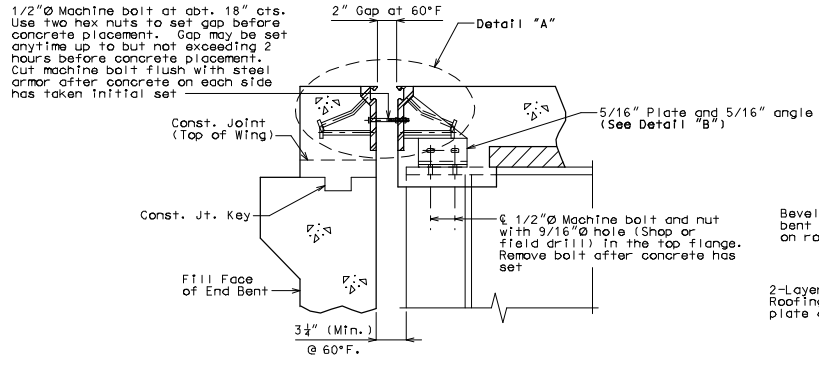

Note: Strip seal gland not shown for clarity.  
SECTION A-A

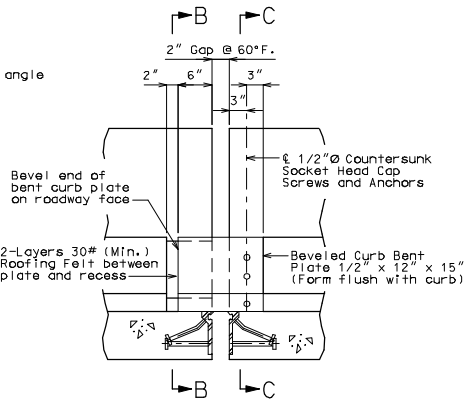

Note: Strip seal gland not shown for clarity.  
PART ELEVATION OF BARRIER CURB

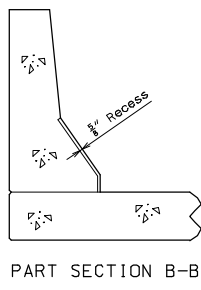

PART SECTION B-B

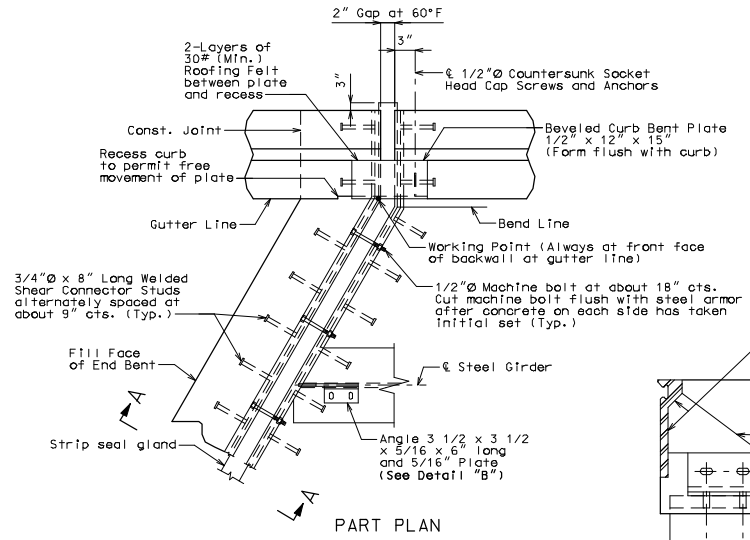

PART PLAN

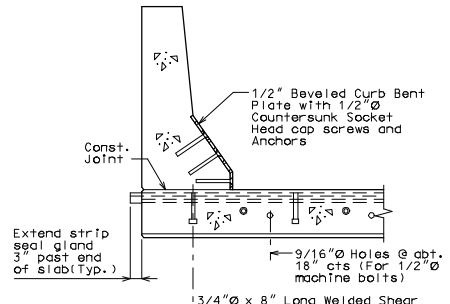

PART SECTION C-C

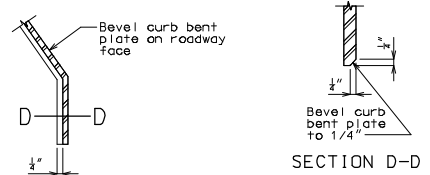

SECTION D-D

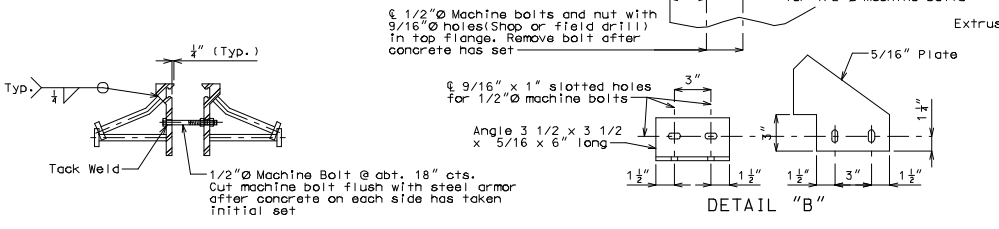

DETAILS OF STRIP SEAL AT END BENT NO.

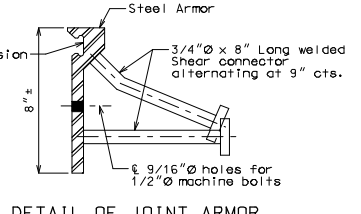

DETAIL OF JOINT ARMOR

PART ELEVATION AT END OF BEVELED CURB BENT PLATE

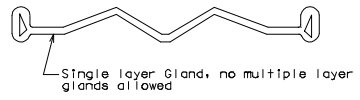

DETAIL OF GLAND

Detailed Checked

Note: This drawing is not to scale. Follow dimensions.

Sheet No. of

STS07

IF A SEAL IS PRESENT ON THIS SHEET IT HAS BEEN ELECTRONICALLY SEALED AND DATED.