

ROUTE	STATE	DISTRICT	SHEET NO.	"THIS MEDIA SHOULD NOT BE CONSIDERED A CERTIFIED DOCUMENT."
	MO			
JOB NO.				
CONTRACT ID.				
PROJECT NO.				DATE
COUNTY				

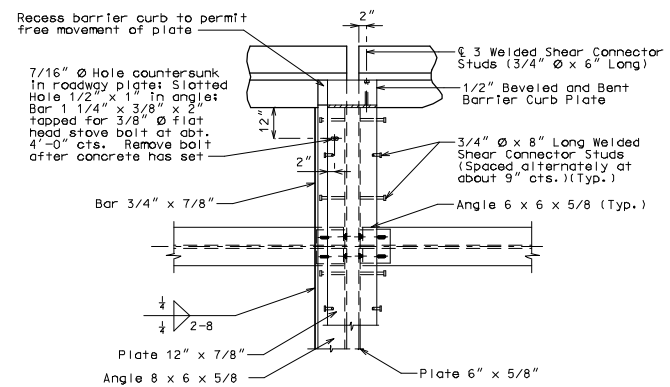

PART PLAN

Note: Concrete vent holes not shown for clarity.

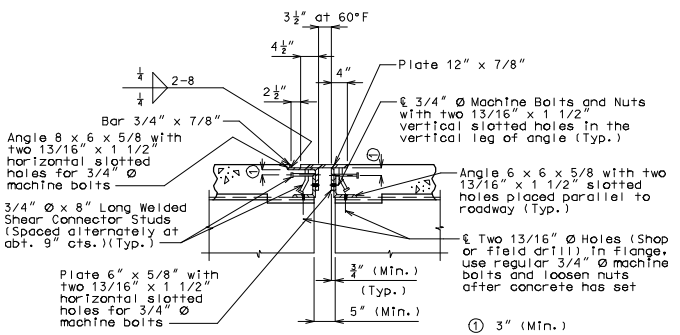

PART SECTION AT INTERMEDIATE BENT

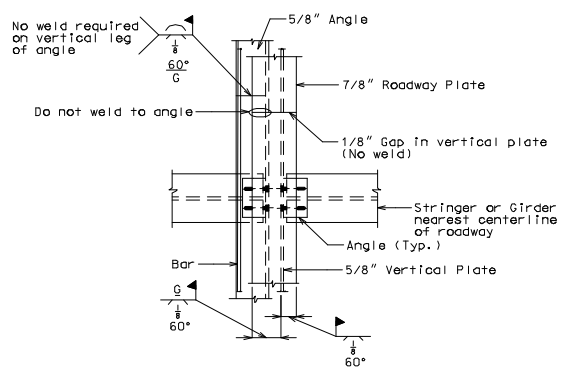

PERMISSIBLE FIELD SPLICE AT INT. BENT

Detailed Checked

Note: This drawing is not to scale. Follow dimensions.

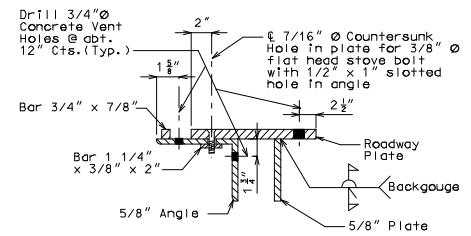

PART SECTION (TYPICAL)

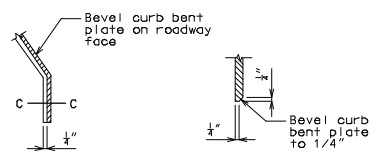

PART ELEVATION AT END OF BEVELED CURB BENT PLATE

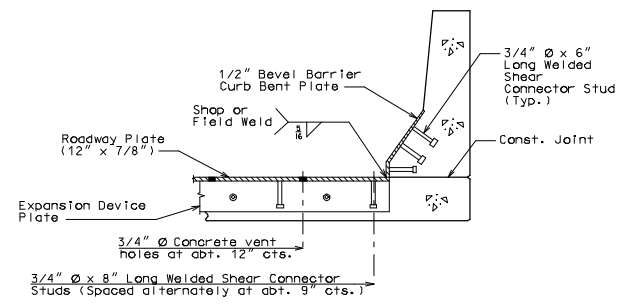

PART SECTION A-A

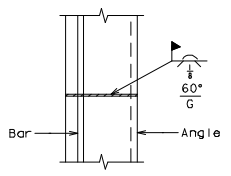

PART PLAN OF ANGLE AND BAR

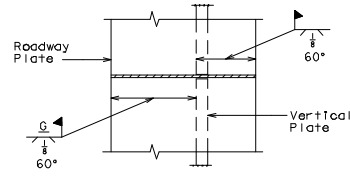

PART PLAN ROADWAY PLATE AND VERTICAL PLATE

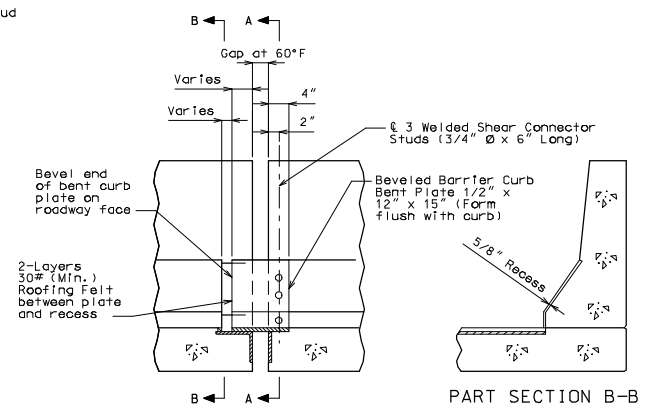

ELEVATION OF BARRIER CURB

PART SECTION B-B

DETAILS OF FLAT PLATE EXPANSION DEVICE AT END BENT NO.

Sheet No. of

IF A SEAL IS PRESENT ON THIS SHEET IT HAS BEEN ELECTRONICALLY SEALED AND DATED.