

ROUTE	STATE	DISTRICT	SHEET NO.	*THIS MEDIA SHOULD NOT BE CONSIDERED A CERTIFIED DOCUMENT.* DATE
	MO			
JOB NO.				
CONTRACT ID.				
PROJECT NO.				
COUNTY				

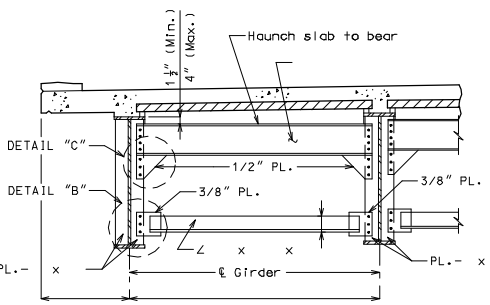

TYPICAL PART SECTION SHOWING END DIAPHRAGMS

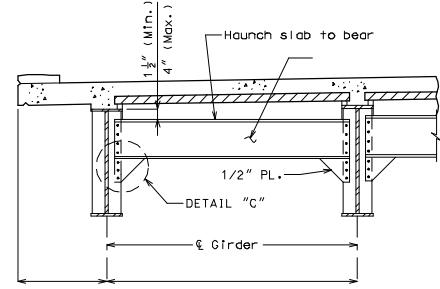

TYPICAL PART SECTION SHOWING END DIAPHRAGMS

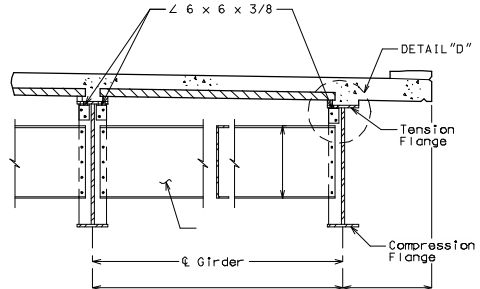

TYPICAL PART SECTION SHOWING CROSS FRAMES AND INTERMEDIATE DIAPHRAGMS TOP FLANGE IN TENSION

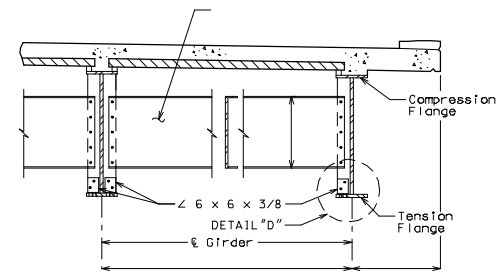

TYPICAL PART SECTION SHOWING INTERMEDIATE DIAPHRAGMS BOTTOM FLANGE IN TENSION

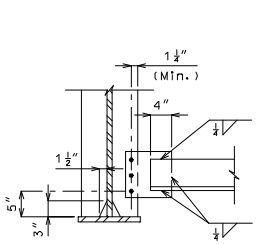

DETAIL "B"

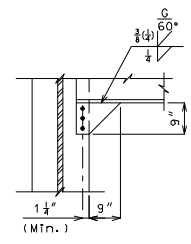

DETAIL "C"

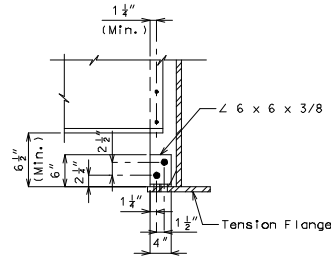

DETAIL "D"

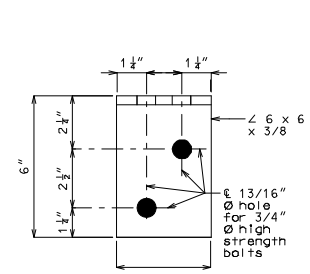

ELEVATION

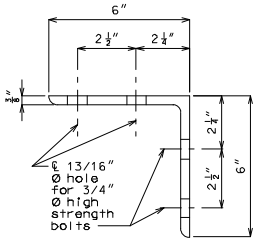

SIDE VIEW

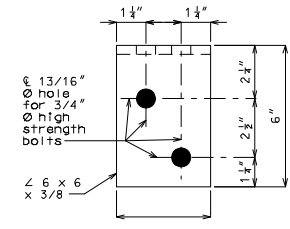

PLAN

Ø 13/16" hole for 3/4" high strength bolts

Note: The two 3/4" Ø H.S. bolts that connect the 6 x 6 x 3/8 angle to the top flange shall be placed so the nut is on the inside of flange (toward the web).

DETAIL OF FLANGE CONNECTION ANGLE

Note to Detailer:

Check with Designer to verify use of Flange Connection Angles, if they are not needed turn the Bridge-Miscellaneous level off.

IF A SEAL IS PRESENT ON THIS SHEET IT HAS BEEN ELECTRONICALLY SEALED AND DATED.