

ELEVATION

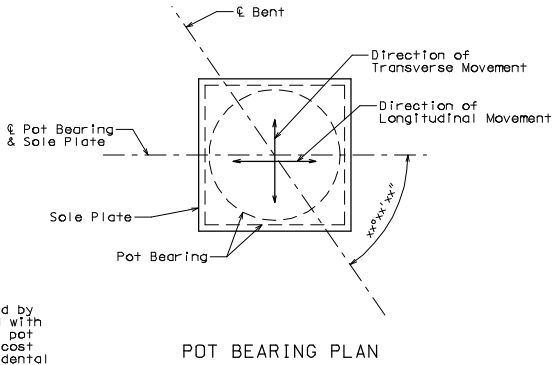

POT BEARING PLAN

BEARING DATA TABLE			
Location			
Fix/Exp.			
Quan. Req'd.			
Design load (kip)	Service limit state	Vertical	max.
		Transverse	min.
	Strength limit state	Vertical	
		Longitudinal	
Translation	Service limit state	Transverse	
		Longitudinal	
	Strength limit state	Transverse	
		Longitudinal	
Rotation (rad.)	Service limit state	Transverse	
		Longitudinal	
*** One Way Longit. Movement			
*** (G) Guide Clearance			
Masonry Plate	Lm		
	Wm		
	Tm		
Auxiliary Plate	La		
	Wa		
	Ta		
Sole Plate	Ls		
	Ws		
	T1		
	T2		
Bearing H			
Anchor Rods	d		
	Rods / Brg.		
Weld Size	W1		
	W2		

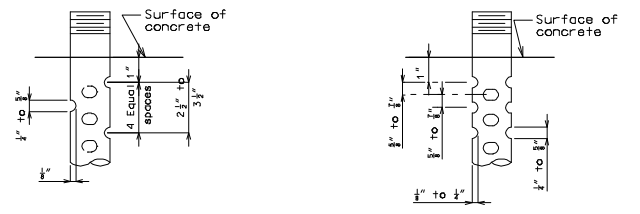

DETAIL OF 3/4" Ø THRU 2 1/2" Ø ANCHOR RODS

OPTIONAL DETAIL OF 1 3/8" Ø THRU 2 1/2" Ø ANCHOR RODS

SWEDGE ANCHOR ROD DETAILS

Notes:

T2 is upstation of T1.

*** One Way Longitudinal Movement is the maximum one way movement (expansion or contraction) of the superstructure when bearings are set at 70 degrees F plus 1" tolerance.

*** On wide structures and on curved structures provisions shall be made for limited lateral movement.

Indicates parts designed by the manufacturer.

DETAILS OF POT BEARING PAD ASSEMBLY

ROUTE	STATE	DISTRICT	SHEET NO.	"THIS MEDIA SHOULD NOT BE CONSIDERED A CERTIFIED DOCUMENT." DATE
	MO			
JOB NO.				
CONTRACT ID.				
PROJECT NO.				
COUNTY				

NOTES:

The bearing design shall conform to the provisions of the latest edition of AASHTO.

The contractor, in coordination with the bearing manufacturer, shall be responsible for sizing the sole plate and masonry plate and determining the size, number, and location of anchor rods based on the load and movement capacities, indicated in the Bearing Data

The contractor shall submit calculations sealed by a Professional Engineer, licensed in the state of Missouri, indicating conformance with design load and material criteria in the contract documents.

* Maximum vertical dimension of the complete bearing. If the actual bearing dimension differs, adjustments shall be made in the thickness of the sole plate, masonry plate and concrete pad as needed by the contractor at no additional cost to the owner. Contractor shall submit proposed method of adjustment to Engineer for approval.

** Estimated horizontal dimension of the pot bearing device. If the actual dimension differs, adjust the size of the sole plate and masonry plate as needed by the contractor at no additional cost to the owner.

*** The temperature of the steel adjacent to the elastomeric should be kept below 250°F.

The dimension "H" in the Bearing Data Table represents the assumed total height of bearing mechanism between the sole plate and masonry plate used by the designer to establish the pedestal elevations.

The bearings shall be manufactured pot bearings, designed for the load and movement capacities indicated in the Bearing Data Table.

All expansion Bearings shall have maximum friction coefficient of 3%.

Steel for pot bearings shall be AASHTO M270 Grade 50 and shall be galvanized. Steel for sole plate and masonry plates shall be AASHTO M270 Grade 50.

Anchor rods shall conform to ASTM F1554 Grade 55. The anchor rods shall be the swedge-type and shall have a minimum diameter of 1 1/2-inches and extend a minimum of 3-inches into the concrete. Swedging shall be 1-inch less than the extension into the concrete.

Anchor rods shall be installed using a hardened steel washer at each exposed location.

Washers shall conform to ASTM F463.

Certified mill test reports, conforming to the requirements of the specifications, for the metals for the pot bearing device, sole plate, masonry plate and anchor rods shall be submitted.

The masonry plate shall be prepared per the specifications and shop-coated with one coat of inorganic zinc primer (5 mils minimum).

The sole plate shall be prepared per the specifications and shop-coated with two coats of inorganic zinc primer (5 mils minimum).

The bearing device, sole plate and masonry plate shall be assembled in the shop and the bearing assembly shall be field welded to the bottom flange of the steel cap beam. The welds shall be designed for the load capacities indicated in the Bearing Data Table.

After installation of the bearings, any uncoated or damaged surfaces of the masonry and sole plates shall be prepared in accordance with the specifications and field-coated with inorganic zinc primer (5 mils minimum)

After installation of the bearings and field-applied prime coats, the surfaces of the masonry and sole plates shall be field-coated with System G intermediate and finish coat.

All bearings shall be marked prior to shipping. The marks shall include the bearing location on the bridge and a direction arrow that points up-station. All marks shall be permanent and be visible after the bearing is installed.

The pot bearing device, sole plate, masonry plate, anchor rods, washers, anchor rod wells and any other appurtenances included in the fabrication and installation of the pot bearing device shall be incidental to the pay item "Pot Bearings".

Whenever jacking of the Superstructure is needed to reset the bearings, the contractor shall submit a jacking sequence for approval.

Detailed Checked

Note: This drawing is not to scale. Follow dimensions.

Sheet No. of

IF A SEAL IS PRESENT ON THIS SHEET IT HAS BEEN ELECTRONICALLY SEALED AND DATED.