

ROUTE	STATE	DISTRICT	SHEET NO.	"THIS MEDIA SHOULD NOT BE CONSIDERED A CERTIFIED DOCUMENT." DATE _____
	MO			
JOB NO.				
CONTRACT ID.				
PROJECT NO.				
COUNTY				

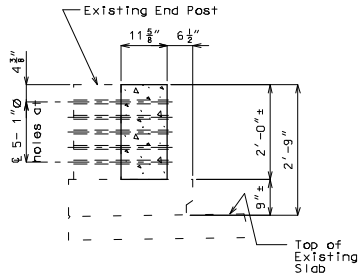

PART SECTION THRU ENDPST
SHOWING HOLE SPACING
(REINFORCEMENT NOT SHOWN FOR CLARITY)

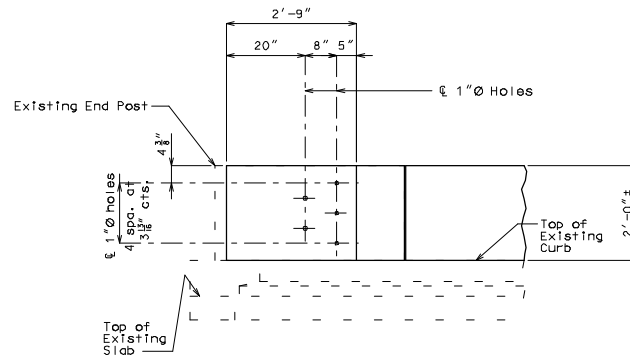

PART SECTION NEAR ENDPST
SHOWING HOLE SPACING
(REINFORCEMENT NOT SHOWN FOR CLARITY)

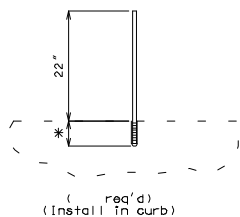

DETAIL OF VERTICAL
RESIN ANCHOR SYSTEM

* Manufacturer's embedment length

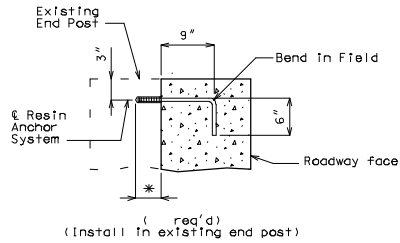

DETAIL OF HORIZONTAL
RESIN ANCHOR SYSTEM

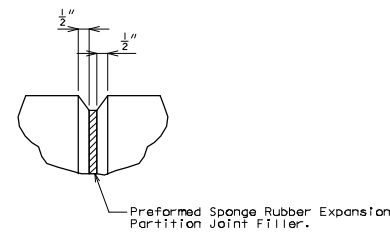

FILLED JOINT DETAIL

Notes:
Concrete traffic barrier delineators shall be placed on top of the safety median barrier curb (Type C) (Type D), as shown on Missouri Standard Plans 617.10 and in accordance with Sec 617. Concrete traffic barrier delineators will be considered completely covered by the contract unit price for Safety Median Barrier Curb (Type C) (Type D).

DETAILS OF CURB BLOCKOUT AT END BENTS

Detailed
Checked

Note: This drawing is not to scale. Follow dimensions.

Sheet No. of

CBO-03

IF A SEAL IS PRESENT ON THIS SHEET IT HAS BEEN ELECTRONICALLY SEALED AND DATED.