

WARSON ROAD IMPROVEMENT PROJECT
FEDERAL PROJECT NUMBER STP-5526(640)
CITY OF CREVE COEUR, MISSOURI

ADDENDUM #2
JANUARY 19, 2018

Bidders are hereby instructed to make the following one (1) change to the Bid Documents for the project referenced above and to consider this change when making a Bid for the work specified therein:

Item #1: Aluminum Handrail. The scope of work required for Item 607-30.25 "Aluminum Handrail" has been revised to be an ADA-accessible handrail according to Missouri Standard Plans for Highway Construction Standard Number 608.40 and shall be powder coated black.

Discussion: The bid item was not originally clear in its intent. The original Job Special Provision and construction details for the handrail have been replaced to provide more clarity.

Addendum Summary

The one (1) change included in this addendum affects one (1) page of the Request for Bid document and one (1) page of the Construction Plans, as summarized below:

Item #1: Clarification of Item 607-30.25 "Aluminum Handrail" involves the addition of a Project Supplemental Specification (3 pages) to the Request for Bid and Missouri Standard Plan 608.40 to the Construction Plans as supplements to these documents. These supplemental specifications and details supersede Job Special Provision "K" (Request for Bid page 57) and Detail #3 on Sheet Number C7.0 of the Construction Plans. No replacement pages are offered or are required as a result of this addendum.

END ADDENDUM #2

PROJECT SUPPLEMENTAL SPECIFICATIONS

The following technical specification supplements the Request for Bid, the Construction Plans, and Addendum #1 for the Warson Road Improvement Project. In case of any conflict between any part or parts of these Supplemental Specifications and the Request for Bid, the Construction Plans, and/or Addendum #1, these Supplemental Specifications shall take precedence and shall govern.

These supplemental specifications specifically supersede the following:

- Job Special Provision "K" (Aluminum Handrail) in the Request for Bid
- Detail #3 "Handrail Detail" on Sheet C7.0 of the Construction Plans

ADDENDUM #2

ITEM #607-30.25 – ALUMINUM HANDRAIL**Description.**

Aluminum Handrail shall be according to the materials and dimensions of “Sidewalk Handrailing Without Balusters,” as shown in Standard Plan 608.40 Handrailing of the Missouri Standard Plans for Highway Construction.

Materials.

Aluminum Handrail shall be constructed of aluminum, of the dimension and type indicated by Standard Plan 608.40.

Aluminum Handrail shall be powder coated black. Powder coating shall be a urethane or triglycidyl isocyanate (TGIC) polyester resin type to meet the following requirements:

- Salt spray corrosion: 500 hours
- Single scribe ASTM B 117 Creepage shall not exceed 0.25” in either direction from the scribe
- Cross hatch adhesion: minimum ASTM D 3359 5A and 5B
- Pencil hardness (gouge and scratch): minimum ASTM D 3363
- Coating thickness: 3 mils
- Chemical resistance: b ASTM D 1308 – coating shall show only a slight circular mark

The Contractor shall submit shop drawings to the City for review and approval prior to ordering the handrail.

Construction Methods.

Aluminum Handrail shall be constructed to meet the requirements of the Americans with Disabilities Act (ADA). Handrail that fails to meet these accessibility requirements shall be removed and replaced by the Contractor at no additional cost to the City.

Aluminum Handrail shall be constructed on the ramp portions of the sidewalk, as suggested on the construction plans. This will require a twelve-inch (12”) rail extension for each rail at each ramp/landing transition.

Aluminum Handrail shall be mounted to the edge of the sidewalk, either by socket or by plate, according to the details of Standard Plan 608.40. The edge of the sidewalk shall be constructed to be thicker at the base of the Aluminum Handrail, as shown on Standard Plan 608.40.

The Contractor shall protect the handrail and its powder coating from damage during all phases of the project.

Method of Measurement.

“Aluminum Handrail” shall be measured to the nearest linear foot of full-height handrail constructed and approved in place.

Handrail extensions at the ramp/landing transitions and the additional sidewalk thickness at the base of the handrail shall not be measured for payment.

Basis of Payment.**ADDENDUM #2**

“Aluminum Handrail” shall be measured and paid according to the contract unit price per linear foot, which price shall include the fabrication, powder coating, delivery, storage, and installation of the handrail, as well as all tools, equipment, material, and labor required.

Separate payment shall not be made for the 12” handrail extensions or for the additional concrete sidewalk thickness at the base of the handrail. This work shall be considered incidental to the Aluminum Handrail item.

ITEM NO.	DESCRIPTION	UNIT
607-30.25	ALUMINUM HANDRAIL	LF

ADDENDUM #2

IF A SEAL IS PRESENT ON THIS SHEET IT HAS BEEN ELECTRONICALLY SEALED AND DATED.

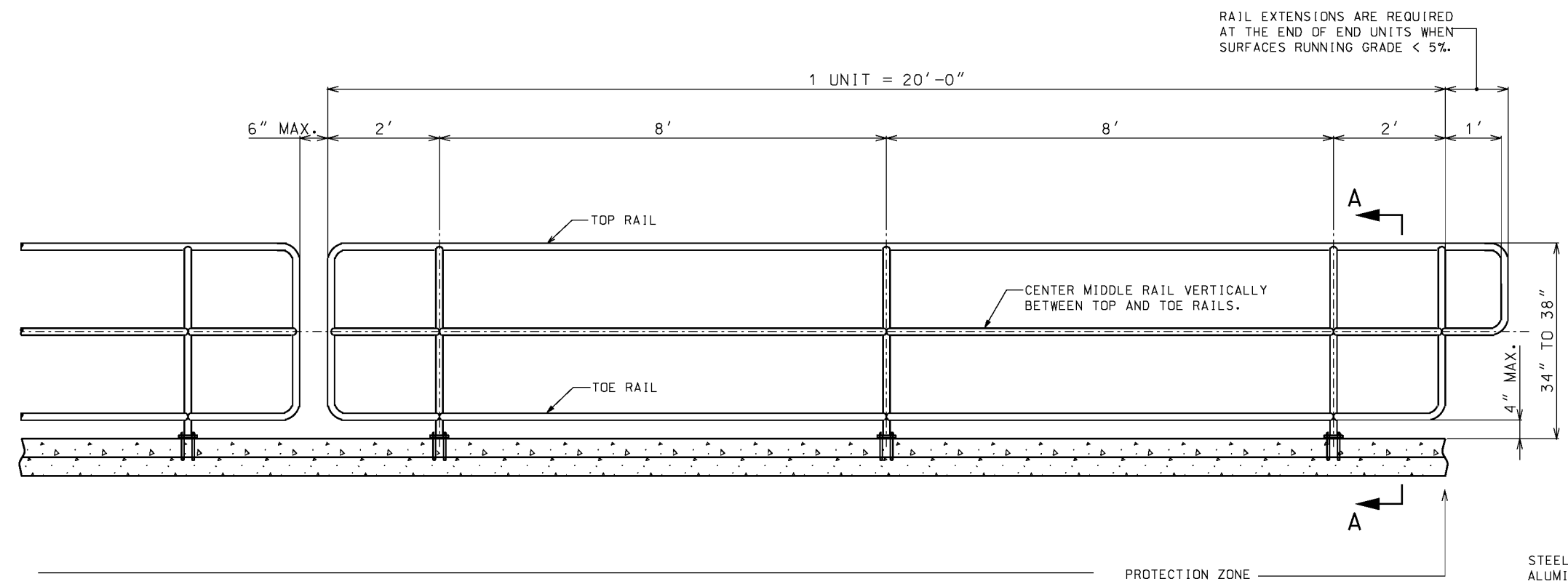

SIDEWALK HANDRAILING WITHOUT BALUSTERS

* CROSS SLOPE: 1.0 % MIN. - 2.0 % MAX.

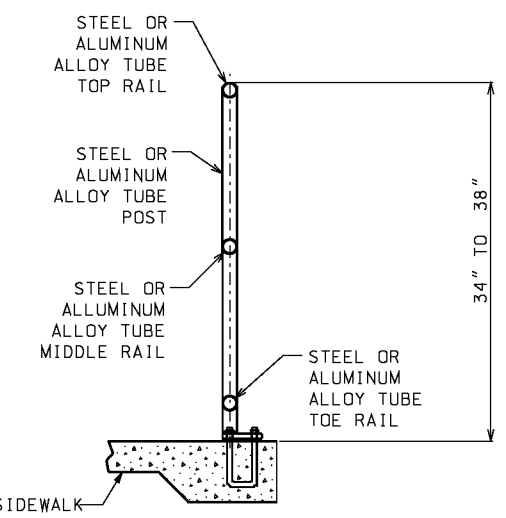

HANDRAILING

ADDENDUM #2

MISSOURI HIGHWAYS AND TRANSPORTATION COMMISSION

105 WEST CAPITOL
JEFFERSON CITY, MO 65102
1-888-ASK-MODOT (1-888-275-6636)

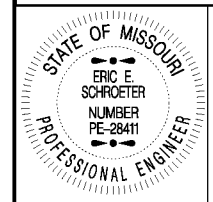

THIS SHEET HAS BEEN SIGNED, SEALED AND DATED ELECTRONICALLY.

HANDRAILING

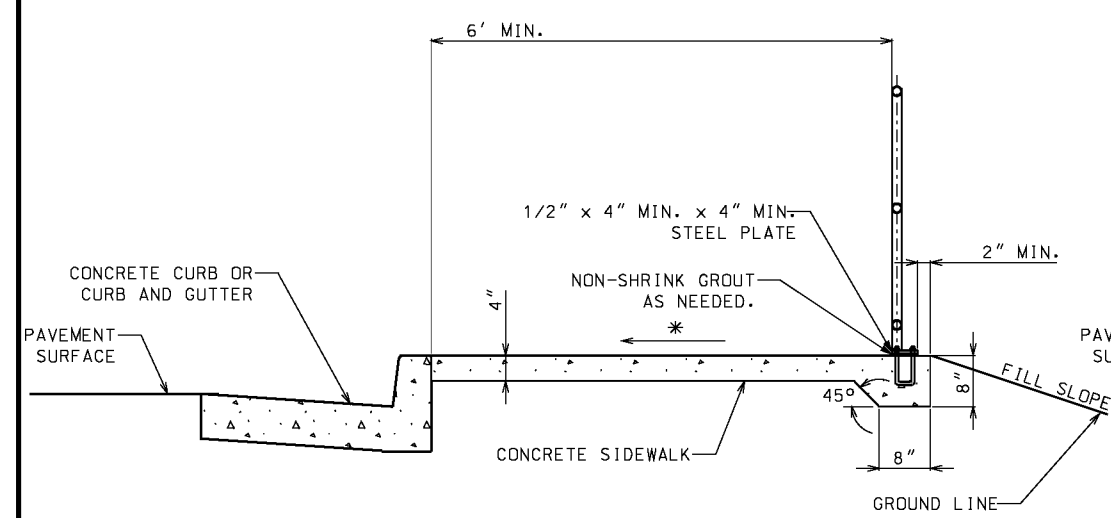

SIDEWALK WITHOUT BUFFER STRIP (SECTION A-A)

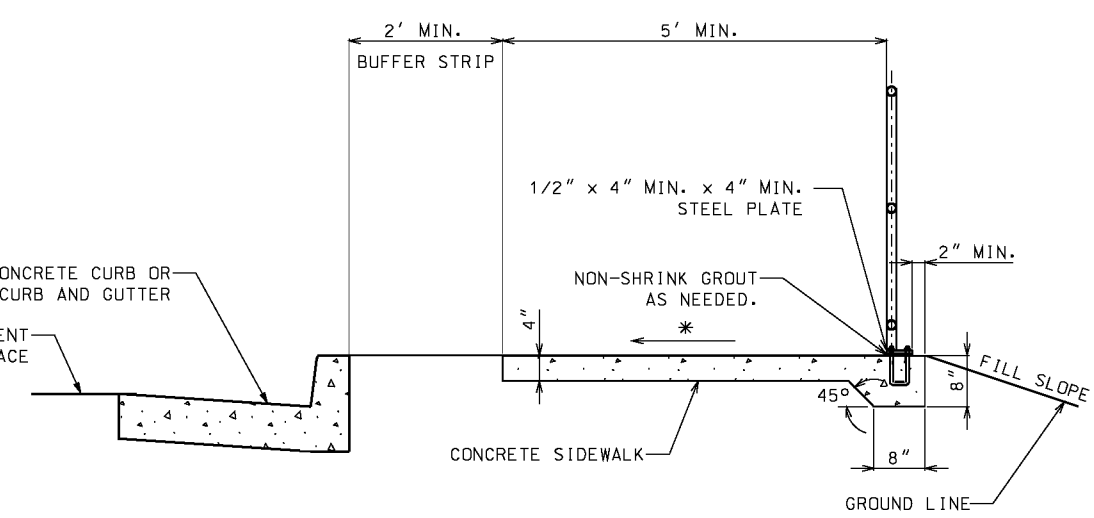

SIDEWALK WITH BUFFER STRIP (SECTION A-A)

FOR GENERAL NOTES AND HANDRAILING REQUIREMENTS ON FILL SLOPES SEE SHEET 3 OF 4

DATE EFFECTIVE: 04/01/2015
DATE PREPARED: 2/20/2015

608.40

SHEET NO.
1 OF 4

IF A SEAL IS PRESENT ON THIS SHEET IT HAS BEEN ELECTRONICALLY SEALED AND DATED.

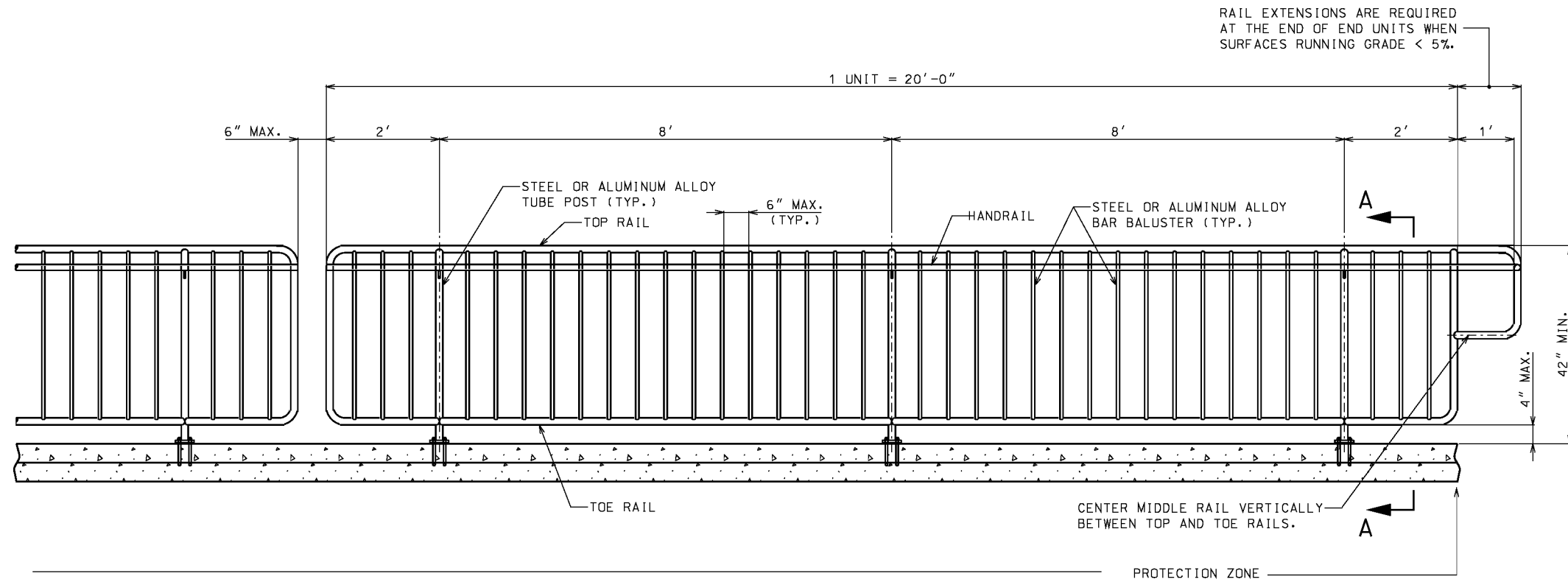

SIDEWALK SAFETY RAIL WITH BALUSTERS AND HANDRAIL

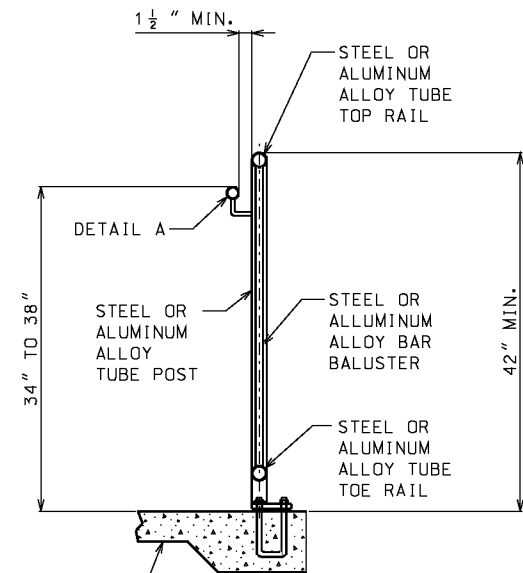

SAFETY RAIL WITH HANDRAIL

ADDENDUM #2

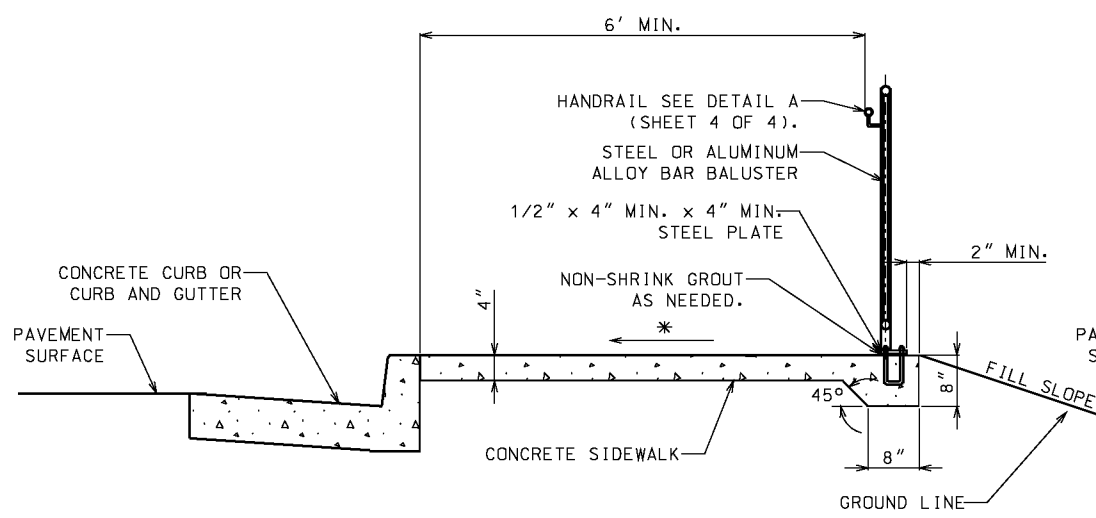

SIDEWALK WITHOUT BUFFER STRIP (SECTION A-A)

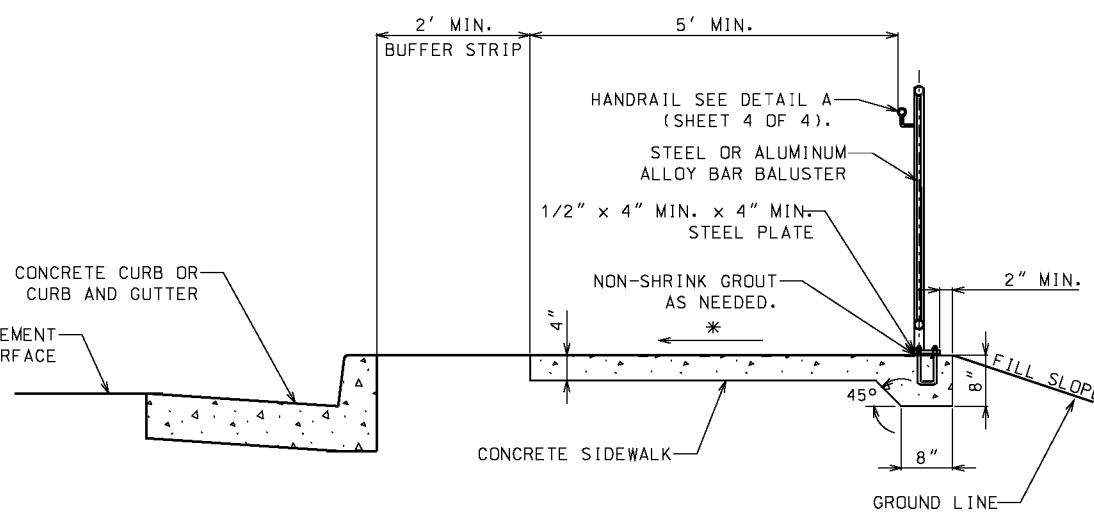

SIDEWALK WITH BUFFER STRIP (SECTION A-A)

* CROSS SLOPE: 1.0% MIN. - 2.0% MAX.

FOR GENERAL NOTES AND HANDRAIL REQUIREMENTS ON FILL SLOPES SEE SHEET 3 OF 4.

	MISSOURI HIGHWAYS AND TRANSPORTATION COMMISSION 105 WEST CAPITOL JEFFERSON CITY, MO 65102 1-888-ASK-MODOT (1-888-275-6636)	
		<p>HANDRAILING</p>
DATE EFFECTIVE: 04/01/2015 DATE PREPARED: 2/20/2015	<p>608.40</p>	SHEET NO. 2 OF 4

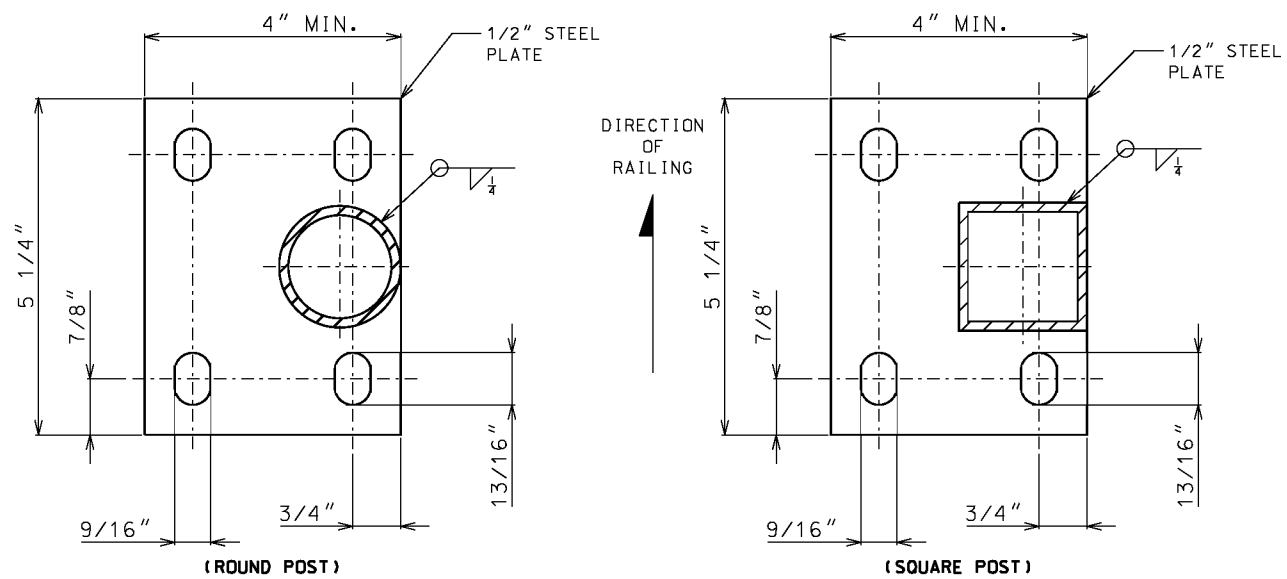

**MOUNTING PLATE DETAIL
(PLAN VIEW)**

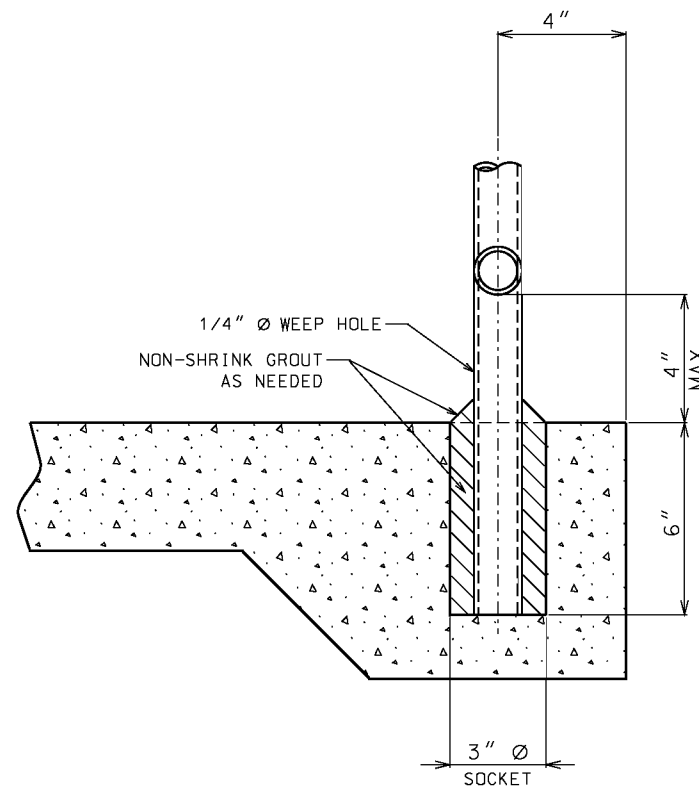

SOCKET MOUNTING DETAIL

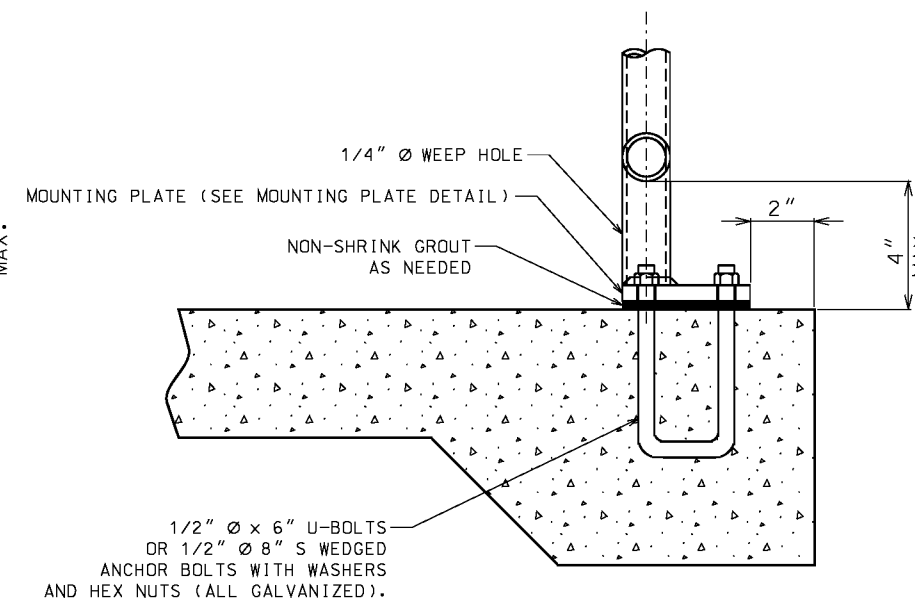

PLATE MOUNTING DETAIL

GENERAL NOTES:

RAILINGS AND POSTS MAY BE EITHER ROUND OR SQUARE STEEL OF GOOD COMMERCIAL WELDABLE QUALITY OR ALUMINUM ALLOY 6061-T6 OR 6063-T6.

STEEL RAILINGS AND POSTS SHALL BE GALVANIZED AFTER FABRICATION IN ACCORDANCE WITH AASHTO M111.

ALL JOINTS SHALL BE CONTINUOUS WELDED AND GROUND SMOOTH.

METAL SAFETY RAIL MUST BE COMPLIANT WITH THE "AMERICAN'S WITH DISABILITIES ACT ACCESSIBILITY GUIDELINES (ADAAG)". EXCEPTIONS MUST BE APPROVED BY THE ENGINEER. ALL OTHER AREAS OF NON-COMPLIANCE SHALL BE REMOVED AND CORRECTED AT THE CONTRACTOR'S EXPENSE.

ALL POSTS SHALL HAVE A 1/4" WEEP HOLE IMMEDIATELY ABOVE THE MOUNTING PLATE.

WHEN INSTALLED THE POSTS SHALL BE PLUMB AND RAILINGS SHALL MATCH THE SLOPE OF THE SIDEWALK.

HANDRAIL REQUIREMENTS		
FILL SLOPE	FILL HEIGHT	HANDRAIL
(1V:3H) OR FLATTER	—	NOT REQUIRED
(1V:3H) OR STEEPER	≥ 6 FT.	REQUIRED
(1V:2H) OR STEEPER	≥ 4 FT.	REQUIRED
(1V:1H) OR STEEPER	≥ 1 FT.	REQUIRED

RAILING AND POST SPECIFICATION				
DESCRIPTION	TYPE	SIZE (DIA.)	WEIGHT (LBS. / FT.)	
			ALUM.	STEEL
RAILING & POST	ROUND	1 1/2"	0.940	2.720
	SQUARE	2" X 2"	1.3094	4.310
BALUSTER	ROUND	1/2"	0.2312	0.668
	RECT.	3/8" X 1/2" STL.	—	0.6375
	SQUARE	1/2" X 1/2" ALUM.	0.2944	—

ADDENDUM #2

MISSOURI HIGHWAYS AND TRANSPORTATION COMMISSION
105 WEST CAPITOL
JEFFERSON CITY, MO 65102
1-888-ASK-MODOT (1-888-275-6636)

HANDRAILING

THIS SHEET HAS BEEN SIGNED, SEALED AND DATED ELECTRONICALLY.

DATE EFFECTIVE: 04/01/2015
DATE PREPARED: 2/20/2015

608.40

SHEET NO.
3 OF 4

IF A SEAL IS PRESENT ON THIS SHEET IT HAS BEEN ELECTRONICALLY SEALED AND DATED.

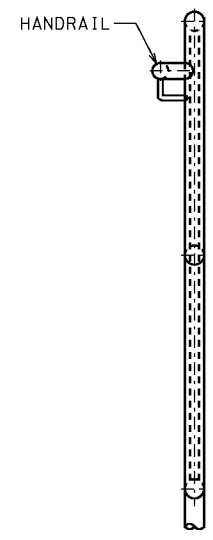
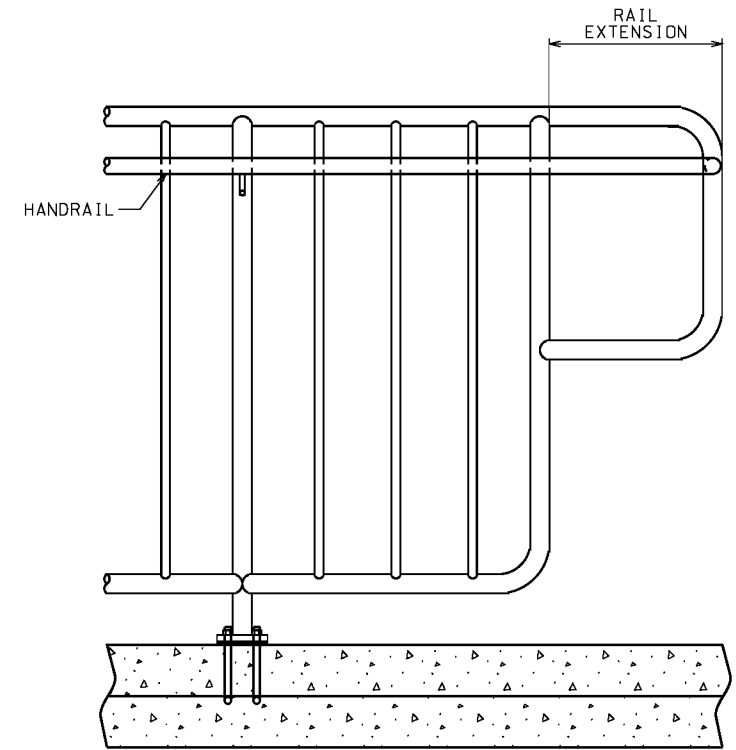
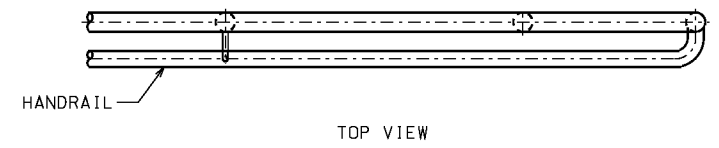

HANDRAIL AND EXTENSION CONNECTION

DETAIL A - HANDRAIL

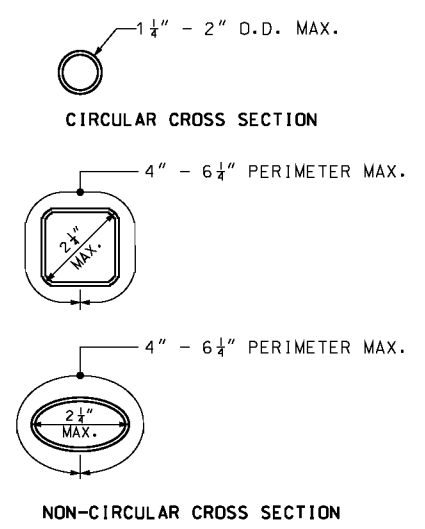

HANDRAIL GRIPPING SURFACES

HANDRAIL NOTES:

HANDRAILS SHALL BE STEEL OF GOOD COMMERCIAL WELDABLE QUALITY OR ALUMINUM ALLOY 6061-T6 OR 6063-T6.

HANDRAILS SHALL BE GALVANIZED AFTER FABRICATION IN ACCORDANCE WITH AASHTO M111.

HANDRAILS SHALL BE AT A CONSISTENT HEIGHT ABOVE WALKING SURFACES.

HANDRAIL GRIPPING SURFACES SHALL BE CONTINUOUS ALONG THEIR LENGTH AND SHALL NOT BE OBSTRUCTED ALONG THEIR TOPS OR SIDES.

THE BOTTOMS OF HANDRAIL GRIPPING SURFACES SHALL NOT BE OBSTRUCTED FOR MORE THAN 20 PERCENT OF THEIR LENGTH.

WHERE HANDRAILS ARE PROVIDED ALONG WALKING SURFACES WITH SLOPES NOT STEEPER THAN 1:20, THE BOTTOMS OF HANDRAIL GRIPPING SURFACES SHALL BE PERMITTED TO BE OBSTRUCTED ALONG THEIR ENTIRE LENGTH WHERE THEY ARE INTEGRAL TO CRASH RAILS OR BUMPER GUARDS.

THE DISTANCE BETWEEN HORIZONTAL PROJECTIONS AND THE BOTTOM OF THE GRIPPING SURFACE SHALL BE PERMITTED TO BE REDUCED BY 1/8" FOR EACH 1/2" OF ADDITIONAL HANDRAIL PERIMETER DIMENSION THAT EXCEEDS 4".

HANDRAIL SURFACES AND ANY SURFACES ADJACENT TO THEM SHALL BE FREE OF SHARP OR ABRASIVE ELEMENTS AND SHALL HAVE ROUNDED EDGES.

HANDRAILS SHALL NOT ROTATE WITHIN THEIR FITTINGS.

ADDENDUM #2

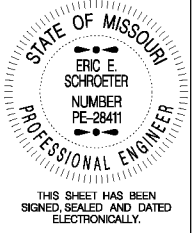
 <p>MISSOURI HIGHWAYS AND TRANSPORTATION COMMISSION</p> <p>105 WEST CAPITOL JEFFERSON CITY, MO 65102 1-888-ASK-MODOT (1-888-275-6636)</p>	
 <p>STATE OF MISSOURI ERIC E. SCHROETER NUMBER PE-28411 PROFESSIONAL ENGINEER</p> <p>THIS SHEET HAS BEEN SIGNED, SEALED AND DATED ELECTRONICALLY.</p>	<p>HANDRAILING</p>
<p>DATE EFFECTIVE: 04/01/2015</p> <p>DATE PREPARED: 2/20/2015</p>	<p>608.40</p>
<p>SHEET NO. 4 OF 4</p>	

IF A SEAL IS PRESENT ON THIS SHEET IT HAS BEEN ELECTRONICALLY SEALED AND DATED.